

DAIMLER

Daimler Trucks North America

Nasser Zamani
Senior Manager
Compliance and Regulatory Affairs

June 24, 2014

Nancy Lewis
Associate Administrator for Enforcement
National Highway Traffic Safety Administration
Attention: Recall Management Division (NVS-215, Rm. W45-206)
1200 New Jersey Avenue S.E.
Washington D.C. 20590

**RE: Defect Information Report – Supplemental Report No. 1
14V-242 FL-653, Meritor Rear Axle Locking Snap Rings
Revised Dealer Notice**

Ms. Lewis,

In accordance with Part 573 of Title 49 of the Code of Federal Regulations, Daimler Trucks North America LLC herewith submits supplemental defect information and copies of documents distributed to dealers.

- (c)(3) Total number of potentially vehicles: 73
- (c)(8)(ii) Dealer and distributor notification: Began and ended: June 24, 2014
- (c)(10) A copy of communications sent to dealers is attached.

Please contact me if you have any questions, or concerns.

Sincerely yours,



Nasser Zamani

Cc: Amy Martin, CAL-OSHA
Attachment

A Daimler Company

Daimler Trucks North America LLC
4747 N. Channel Avenue
Portland OR 97217-7699
503-745-6910 Phone
503-745-5544 Fax
Nasser.Zamani@Daimler.com

June 2014
FL653A-C
NHTSA #13V-538 (FL653AB)
NHTSA #14V-242 (FL653C)
REVISED NOTICE

Subject: Meritor Rear Axle Locking Snap Rings

Models Affected: Specific Freightliner Cascadia vehicles manufactured August 6, 2012, through December 6, 2012, and equipped with ConMet Preset Plus Hubs.

General Information

Daimler Trucks North America LLC, on behalf of its Freightliner Trucks Division, has decided that a defect that relates to motor vehicle safety exists on the vehicles mentioned above.

There are approximately 155 vehicles involved in this campaign.

Certain ConMet Preset Plus Hubs may have been assembled without a locking snap ring. The absence of the locking snap ring could cause accelerated spindle wear, premature degradation of the wheel bearing components, premature wheel oil seal leaks and wheel separation. Separation of the wheel from the rear axle may result in a vehicle crash.

Rear axle assemblies will be inspected for the presence of the locking snap ring. Assemblies without locking snap rings will be repaired.

REVISIONS: Approximately 75 vehicles have been added to the campaign as FL653C. The owner notice of these vehicles is included for your information. The work instruction procedure remains the same for all vehicles.

Additional Repairs

Dealers must complete all outstanding Recall and Field Service campaigns prior to the sale or delivery of a vehicle. A Dealer will be liable for any progressive damage that results from its failure to complete campaigns before sale or delivery of a vehicle.

Owners may be liable for any progressive damage that results from failure to complete campaigns within a reasonable time after receiving notification.

Work Instructions

Please refer to the attached work instructions. Prior to performing the campaign, check the vehicle for a completion sticker (Form WAR260).

Replacement Parts

Replacement parts are now available and can be obtained by ordering the parts number(s) listed below from your facing Parts Distribution Center.

If our records show your dealership has ordered any vehicles involved in campaign number FL653A-C, a list of the customers and vehicle identification numbers will be available on AccessFreightliner.com. Please refer to this list when ordering parts for this recall.

Recall Campaign

Daimler Trucks
North America LLC

June 2014
FL653A-C
NHTSA #13V-538 (FL653AB)
NHTSA #14V-242 (FL653C)
REVISED NOTICE

Table 1 - Replacement Parts for FL653

Campaign Number	Kit Number	Part Description	Part Number	Qty. per Kit	Suggested Wholesale*
FL653A-C	N/A	Gasket	TDA 2208E1123	4 ea	\$3.72 U.S. \$3.79 CAN
		Locking Snap Ring	CM 10026147	Up to 4 ea	\$5.17 U.S. \$5.28 CAN
		Hub Assembly	CM 10036776	Up to 4 ea	\$312.71 U.S. \$318.97CAN
		Completion Sticker	WAR260	1 ea	NO COST

* Please charge all U.S. and Canadian Direct Warranty Customers the above-listed price for the kit, as they are authorized to perform their own Recalls. This pricing does not apply to Export Distributors.

Table 1

Removed Parts

U.S. and Canadian Dealers, please follow Warranty Failed Parts Tracking shipping instructions for the disposition of all removed parts. Export distributors, please destroy removed parts unless otherwise advised.

Labor Allowance

Table 2 - Labor Allowance

Campaign Number	Procedure	Time Allowed (hours)	SRT Code	Damage Code
FL653A-C	Inspect all hubs	1.4	996-0622A	000-Inspected
	Install 1 lock ring	0.6	996-0622B	000-Modifiedx
	Each additional lock ring installed; claim up to 3 times	0.5	996-0622D	000-Modifiedx
	Install 1 lock ring and replace 1 hub	1.2	996-0622C	000-Modifiedx
	Each additional lock ring installed and hub replaced; claim up to 3 times	1.0	996-0622E	000-Modifiedx

Table 2

IMPORTANT: When the Recall has been completed, locate the base completion label in the appropriate location on the vehicle, and attach the red completion sticker provided in the recall kit (Form WAR260). If the vehicle does not have a base completion label, clean a spot on the appropriate location of the vehicle and first attach the base completion label (Form WAR259). If a recall kit is not required or there is no completion sticker in the kit, write the recall number on a blank sticker and attach it to the base completion label.

Claims for Credit

You will be reimbursed for your parts, labor, and handling (landed cost for Export Distributors) by submitting your claim through the Warranty system within 30 days of completing this campaign. Please reference the following information in QuickClaim or OWL:

- Claim type is **Recall**.
- In the FTL Authorization field, enter the campaign number and appropriate condition code (**FL653A, FL653B, etc.**).
- In the Primary Failed Part Number field, enter **25-FL653-000**.

June 2014
FL653A-C
NHTSA #13V-538 (FL653AB)
NHTSA #14V-242 (FL653C)
REVISED NOTICE

- In the Parts field, enter the appropriate part number(s) as shown in the Replacement Parts Table.
- Note: Up to 4 qts of synthetic gear oil may be claimed without prior authorization.
- In the Labor field, first enter the appropriate SRT from the Labor Allowance Table. For administrative time, enter SRT 939-0010A for 0.4 hours.

Note: Each claim should include hub inspection SRT. Add additional SRTs for lock ring installation and hub replacement as appropriate for the repair.

- For OWL, the VMRS Component Code is 018-002-061 and the Cause Code is A1 - Campaign.
- **U.S. and Canada – Reimbursement for Prior Repairs.** When a customer asks about reimbursement, please do the following:
 - Accept the documentation of the previous repair.
 - Make a brief check of the customer's paperwork to see if the repair may be eligible for reimbursement. (See the "Copy of Owner Letter" section of this bulletin for reimbursement guidelines for this recall.)
 - Submit a Campaign Pre-Approval inquiry to the Warranty Campaigns Department for a decision and authorization number.
 - Include the approved amount on your claim in Other Charges section.
 - In the claim story, first note the authorization number and that the claim includes a reimbursement.
 - Retain the documentation and provide it to Warranty Campaigns or Claims Processing if requested.
 - When your claim is paid, reimburse the customer the appropriate amount.

IMPORTANT: ServicePro or OWL must be viewed prior to performing the recall to ensure the vehicle is involved and the campaign has not been previously completed. Also, check for a completion sticker prior to beginning work.

U.S. and Canadian dealers, contact the Warranty Campaigns Department from 7:00 a.m. to 4:00 p.m. Pacific Time, Monday through Friday, via Web inquiry at AccessFreightliner.com / Support / My Tickets and Submit an Inquiry, or the Customer Assistance Center at (800) 385-4357, after normal business hours, if you have any questions or need additional information. Export distributors, submit a Web inquiry or contact your International Service Manager.

U.S. and Canadian Dealers: To return excess kit inventory related to this campaign, U.S. dealers must submit a Parts Authorization Return (PAR) to the Memphis PDC. Canadian dealers must submit a PAR to their facing PDC. All kits must be in resalable condition. PAR requests must include the original purchase invoice number. Export Distributors: Excess inventory is not returnable.

The letter notifying U.S. and Canadian vehicle owners is included for your reference.

Please note that the National Traffic and Motor Vehicle Safety Act, as amended (Title 49, United States Code, Chapter 301), requires the owner's vehicle(s) be corrected within a reasonable time after parts are available to you. The Act states that failure to repair a vehicle within 60 days after tender for repair shall be prima facie evidence of an unreasonable time. However, circumstances of a particular situation may reduce the 60 day period. Failure to repair a vehicle within a reasonable time can result in either the obligation to (a) replace the vehicle with an identical or reasonably equivalent vehicle, without charge, or (b) refund the purchase price in full, less a reasonable allowance for depreciation. The Act further prohibits dealers from selling a vehicle unless all outstanding recalls are performed. Any lessor is required to send a copy of the recall notification to the lessee within 10 days. Any subsequent stage manufacturer is required to forward this notice to its distributors and retail outlets within five working days.

Recall Campaign

Daimler Trucks
North America LLC

June 2014
FL653C
NHTSA #14V-242

Copy of Notice to Owners

Subject: Meritor Rear Axle Locking Snap Rings

This notice is sent to you in accordance with the requirements of the National Traffic and Motor Vehicle Safety Act.

Daimler Trucks North America LLC, on behalf of its Freightliner Trucks Division, has decided that a defect which relates to motor vehicle safety exists on specific Freightliner Cascadia vehicles manufactured August 6, 2012, through December 6, 2012, equipped with ConMet Preset Plus Hubs..

Certain ConMet Preset Plus Hubs may have been assembled without a locking snap ring. The absence of the locking snap ring could cause accelerated spindle wear, premature degradation of the wheel bearing components, premature wheel oil seal leaks and wheel separation. Separation of the wheel from the rear axle may result in a vehicle crash.

Rear axle assemblies will be inspected for the presence of the locking snap ring. Assemblies without locking snap rings will be repaired.

Please contact an authorized Daimler Trucks North America dealer to arrange to have the recall performed and to ensure that parts are available at the dealership. To locate an authorized dealer, search online at www.Daimler-TrucksNorthAmerica.com. The Recall will take approximately one to four hours depending on the repair and will be performed at no charge to you.

You may be liable for any progressive damage that results from your failure to complete the Recall within a reasonable time after receiving notification.

If you do not own the vehicle that corresponds to the identification number(s) which appears on the Recall Notification, please return the notification to the Warranty Campaigns Department with any information you can furnish that will assist us in locating the present owner. If you have leased this vehicle, Federal law requires that you forward this notice to the lessee within 10 days. If you are a subsequent stage manufacturer, Federal law requires that you forward this notice to your distributors and retail outlets within five working days. If you have paid to have this recall condition corrected prior to this notice, you may be eligible to receive reimbursement. Please see the reverse side of this notice for details.

If you have questions about this Recall, please contact the Warranty Campaigns Department at (800) 547-0712, 7:00 a.m. to 4:00 p.m. Pacific Time, Monday through Friday, e-mail address DTNA.Warranty.Campaigns@Daimler.com, or the Customer Assistance Center at (800) 385-4357 after normal business hours. If you are not able to have the defect remedied without charge and within a reasonable time, you may wish to submit a complaint to the Administrator, National Highway Traffic Safety Administration, 1200 New Jersey Avenue, SE., Washington, DC 20590; or call the Vehicle Safety Hotline at (888) 327-4236 (TTY: 800-424-9153); or to <http://www.safercar.gov>.

We regret any inconvenience this action may cause but feel certain you understand our interest in motor vehicle safety.

WARRANTY CAMPAIGNS DEPARTMENT

Enclosure

Copy of Notice to Owners

Subject: Meritor Rear Axle Locking Snap Rings

This notice is sent to you in accordance with the requirements of the National Traffic and Motor Vehicle Safety Act.

Daimler Trucks North America LLC, on behalf of its Freightliner Trucks Division, has decided that a defect which relates to motor vehicle safety exists on specific Freightliner Cascadia vehicles manufactured August 14, 2012, through December 5, 2012, equipped with ConMet Preset Plus Hubs..

Certain ConMet Preset Plus Hubs may have been assembled without a locking snap ring. The absence of the locking snap ring could cause accelerated spindle wear, premature degradation of the wheel bearing components, premature wheel oil seal leaks and wheel separation. Separation of the wheel from the rear axle may result in a vehicle crash.

Rear axle assemblies will be inspected for the presence of the locking snap ring. Assemblies without locking snap rings will be repaired.

Please contact an authorized Daimler Trucks North America dealer to arrange to have the recall performed and to ensure that parts are available at the dealership. To locate an authorized dealer, search online at www.Daimler-TrucksNorthAmerica.com. The Recall will take approximately one to four hours depending on the repair and will be performed at no charge to you.

You may be liable for any progressive damage that results from your failure to complete the Recall within a reasonable time after receiving notification.

If you do not own the vehicle that corresponds to the identification number(s) which appears on the Recall Notification, please return the notification to the Warranty Campaigns Department with any information you can furnish that will assist us in locating the present owner. If you have leased this vehicle, Federal law requires that you forward this notice to the lessee within 10 days. If you are a subsequent stage manufacturer, Federal law requires that you forward this notice to your distributors and retail outlets within five working days. If you have paid to have this recall condition corrected prior to this notice, you may be eligible to receive reimbursement. Please see the reverse side of this notice for details.

If you have questions about this Recall, please contact the Warranty Campaigns Department at (800) 547-0712, 7:00 a.m. to 4:00 p.m. Pacific Time, Monday through Friday, e-mail address DTNA.Warranty.Campaigns@Daimler.com, or the Customer Assistance Center at (800) 385-4357 after normal business hours. If you are not able to have the defect remedied without charge and within a reasonable time, you may wish to submit a complaint to the Administrator, National Highway Traffic Safety Administration, 1200 New Jersey Avenue, SE., Washington, DC 20590; or call the Vehicle Safety Hotline at (888) 327-4236 (TTY: 800-424-9153); or to <http://www.safercar.gov>.

We regret any inconvenience this action may cause but feel certain you understand our interest in motor vehicle safety.

WARRANTY CAMPAIGNS DEPARTMENT

Enclosure

December 2013
FL653A
NHTSA #13V-538

Reimbursement to Customers for Repairs Performed Prior to Recall

If you have already **paid** to have this recall condition corrected you may be eligible to receive reimbursement.

Requests for reimbursement may include parts and labor. Reimbursement may be limited to the amount the repair would have cost if completed by an authorized Daimler Trucks North America LLC dealer. The following documentation must be presented to your dealer for consideration for reimbursement.

Please provide original or clear copies of all receipts, invoices, and repair orders that show

- The name and address of the person who paid for the repair
- The Vehicle Identification Number (VIN) of the vehicle that was repaired
- What problem occurred, what repair was done, when the repair was done
- Who repaired the vehicle
- The total cost of the repair expense that is being claimed
- Proof of payment for the repair (such as the front and back of a cancelled check or a credit card receipt)

Reimbursement will be made by check from your Daimler Trucks North America LLC dealer.

Please speak with your Daimler Trucks North America LLC authorized dealer concerning this matter.

Work Instructions

Subject: Meritor Rear Axle Locking Snap Rings

Models Affected: Specific Freightliner Cascadia vehicles manufactured August 14, 2012, through December 5, 2012, equipped with ConMet Preset Plus Hubs.

REVISIONS: Approximately 75 vehicles have been added to the campaign as FL653C. The owner notice of these vehicles is included for your information. The work instruction procedure remains the same for all vehicles.

Lock Ring Inspection and Repairs

1. Check the base label (Form WAR259) for a completion sticker for FL653 (Form WAR260), indicating this work has been completed. If a completion sticker is present, no work is needed. If a completion sticker is not present, proceed to the next step.
2. Park the vehicle on a level surface, shut down the engine, and set the parking brake. Chock the tires.

IMPORTANT: The following steps apply to both wheel ends of each drive axle.

NOTE: Oil will spill as the drive axle shaft and the wheel hub are removed. Place a suitable container under the drive axle flange to catch any spilled oil. Dispose of the oil properly.

3. Remove the drive axle stud nuts and washers. See **Fig. 1**.

NOTICE

When tapping the drive axle flange, avoid striking the drive axle studs. If struck, the studs may bend or break, or the stud threads can be damaged. Replace damaged studs.

4. Using a hammer and a soft drift, such as one made of brass, sharply tap the center portion of the drive axle flange. The shaft will usually spring slightly outward after the seal has broken.

NOTE: Even if the drive axle shaft doesn't spring outward, the seal may have loosened enough to allow the shaft to be pulled from the axle housing. If the seal has not broken, repeat the step above.

5. If DCDL is installed on the vehicle, use the DCDL switch in the cab to engage the lock. An indicator light comes on when the differential lock is engaged. Turn the appropriate wheels to ensure the lock is fully engaged.

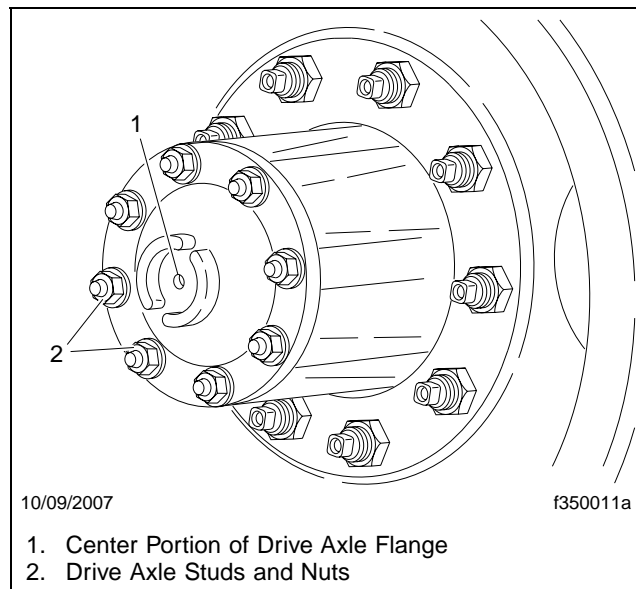

Fig. 1, Wheel Assembly and Hub

June 2014
FL653A-C
NHTSA #13V-538 (FL653AB)
NHTSA 14V-242 (FL653C)
REVISED NOTICE

6. If so equipped, remove the tapered dowels and washers from the drive axle flange.
7. Remove the drive axle shaft.
8. Remove and discard the gasket.
9. Check for the presence of a lock ring. See **Fig. 2**.
If the lock ring is present, go step 12.
If the lock ring is not present, continue to the next step.
10. Check the torque of the spindle nut to determine if it is 500 lbf·ft (678 N·m).
If it is below 500 lbf·ft (678 N·m), replace the hub and check the spindle for damage. Go to Hub Replacement and Spindle Inspection on page 8.
If it is 500 lbf·ft (678 N·m), continue to the next step.

NOTICE

When opening the lock ring to install or remove it, use the tabs, and be careful not to deform it permanently. If the lock ring is damaged or bent, replace it with a new one.

11. Install the lock ring, as follows.
 - 11.1 One of the holes in the face of the spindle nut will line up with a hole in the washer. Insert the lock tab of the lock ring through aligned holes.
 - 11.2 Using the tabs, seat the lock ring in the machined grooves of the spindle nut. See **Fig. 2**.
12. Install a new gasket and the drive axle shaft. The splined end of the axle shaft must seat before the drive axle flange will fit over the studs.
13. If needed, install the tapered dowels and washers on the drive axle studs. Install the drive axle stud nuts and washers. Using the sequence shown in **Fig. 3**, tighten the nuts to the torque values given in the table in **Table 3**.

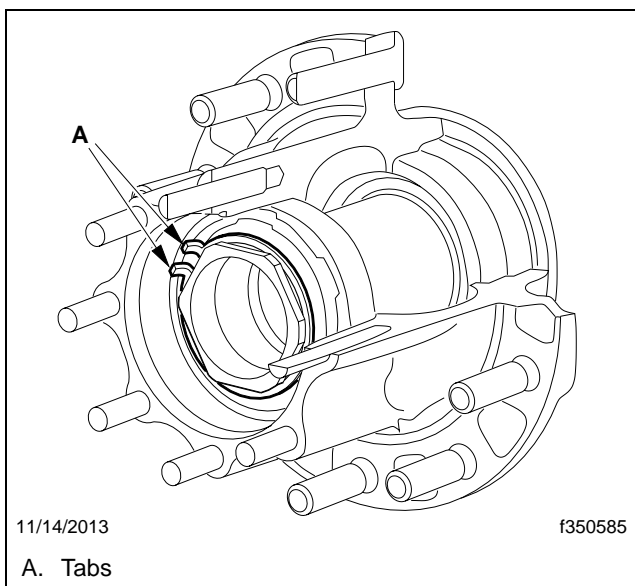

Fig. 2, Lock Ring, ConMet PreSet Plus Hub

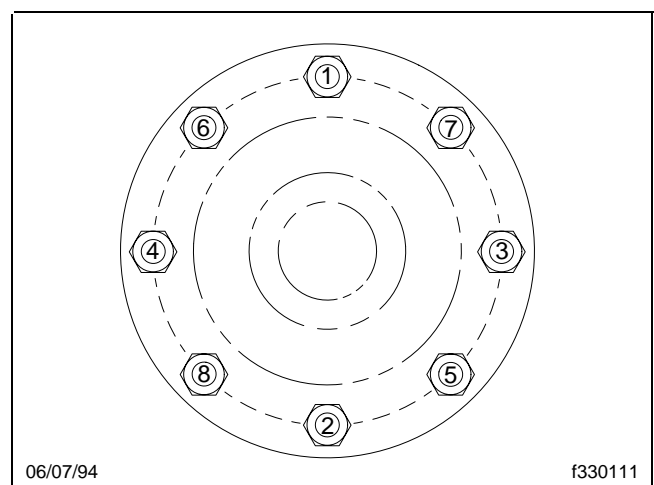

Fig. 3, Tightening Sequence, Drive Axle Stud Nuts

Torque Values, Drive Axle Stud Nuts		
Description	Size (grade 8)	Torque: lbf·ft (N·m)
With Dowels	5/8–18	130 to 140 (175 to 190)
Without Dowels	5/8–18	150 to 170 (203 to 230)

Table 3, Torque Values, Drive Axle Stud Nuts

WARNING

Add oil to the axle housing bowl or the wheel hub after the drive axle shaft and wheel hub have been serviced. Failure to add oil will damage the wheel bearings and cause them to seize during vehicle operation. Seized bearing rollers can cause sudden damage to the tire or axle, possibly resulting in personal injury.

14. Lubricate the wheel bearings, as follows.

IMPORTANT: When removing the fill port plug, make sure the rubber O-ring is attached to it and not stuck inside the fill port.

14.1 Clean the area surrounding the oil fill port plug, then remove the plug and O-ring.

14.2 Using a clean funnel, add 1.0 quart (0.95 liter) of the recommended drive axle lubricant through the oil fill port. For recommended lubricants, see **Table 4**.

14.3 Install the fill port plug, and tighten it 20 to 25 lbf·ft (27 to 34 N·m).

Meritor Drive Axle Recommended Lubricant			
Recommended Lubricant Type	Ambient Temperature	Lubricant SAE Viscosity Grade	Meritor Specification
Synthetic Gear Oil	–40°F (–40°C) and Up*	75W–90	0–76–N
	–40°F (–40°C) and Up	75W–140	0–76–M

* There is no upper limit on these outside temperatures, but axle sump temperature must never exceed 250°F (121°C).

Table 4, Meritor Drive Axle Recommended Lubricant

15. Clean a spot on the base label (Form WAR259). Write the campaign number, FL653, on a blank red completion sticker (Form WAR260) to indicate the work has been completed and attach it to the base label.

Hub Replacement and Spindle Inspection

See **Fig. 4** for a diagram of the wheel-end assembly.

1. Raise the rear of the vehicle until the tires clear the ground. Then place safety stands under the axles.
2. Back off the slack adjusters to release the rear axle brake shoes.

WARNING

Breathing brake lining dust (asbestos or nonasbestos) could cause lung cancer or lung disease. OSHA has set maximum levels of exposure and requires workers to wear an air purifying respirator approved by MSHA or NIOSH. Wear a respirator at all times when servicing the brakes, starting with removal of the wheels and continuing through assembly.

Recall Campaign

Daimler Trucks
North America LLC

June 2014
FL653A-C
NHTSA #13V-538 (FL653AB)
NHTSA 14V-242 (FL653C)
REVISED NOTICE

3. Remove the wheel and tire assemblies from the rear axles. For instructions, see **Group 40** in the *Cascadia Workshop Manual*.
4. Remove the brake drums. For instructions, see **Section 35.01, Subject 160** in the *Cascadia Workshop Manual*.

IMPORTANT: Do not exceed 50 lbf-ft (68 N-m) of torque when removing a PreSet Plus hub using the spindle-nut system as a hub puller.

5. Loosen the spindle nut. As the spindle nut is loosened, it can act as a hub puller. However, if the hub will not come off of the spindle without exceeding 50 lbf-ft (68 N-m) of torque, remove the spiral snap ring (see **Fig. 5**) and then the spindle nut assembly.

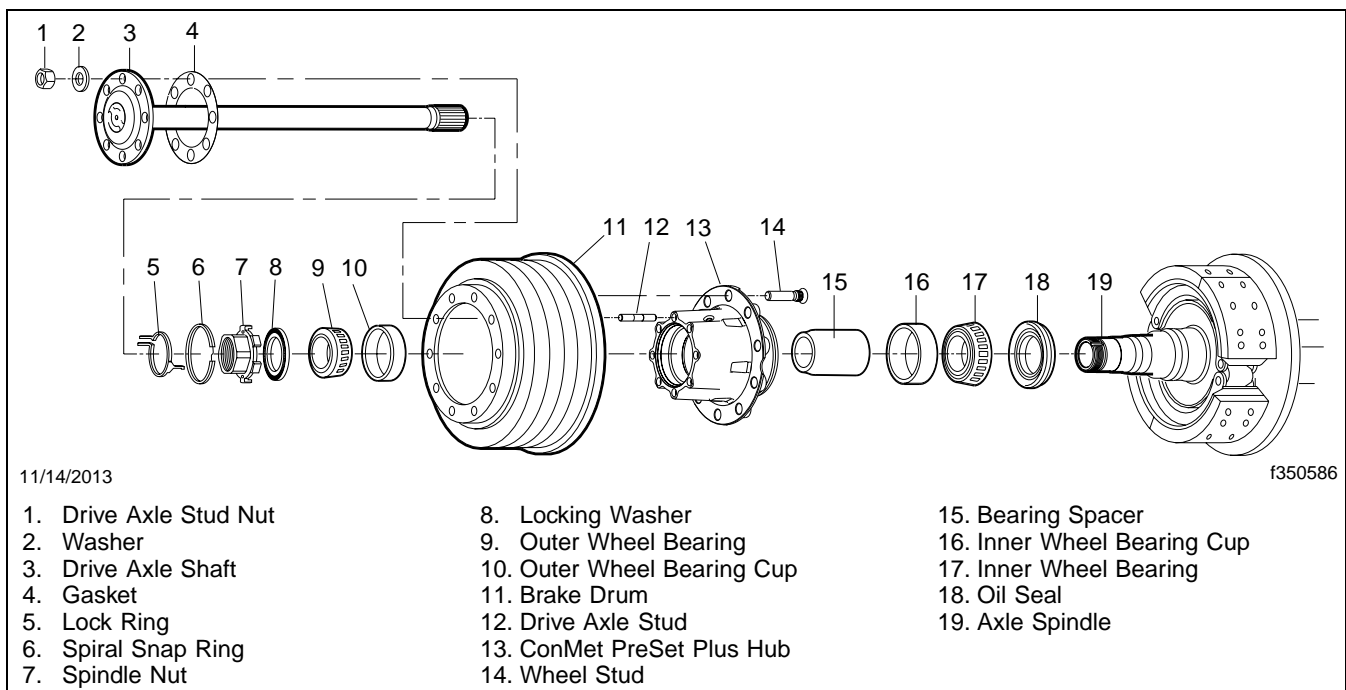

Fig. 4, Wheel End Assembly

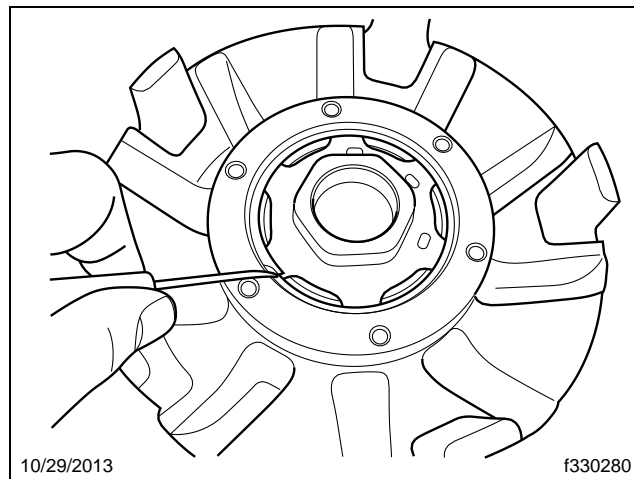

Fig. 5, Removing a Spiral Snap Ring

June 2014
FL653A-C
NHTSA #13V-538 (FL653AB)
NHTSA 14V-242 (FL653C)
REVISED NOTICE

NOTICE

Be careful not to let the outer wheel bearing drop from the axle spindle. Dropping the bearing can warp the cage or damage the rollers, ruining the bearing. On vehicles equipped with WABCO ABS, use care when working with the hubs. To prevent damage to the tone wheel, do not drop the hub, or lay it down in a way that would damage the tone wheel.

6. Move the hub about 1/2 inch (13 mm) to jar loose the outer wheel bearing (allow the hub-only assembly to rest on the axle spindle; be careful not to damage the axle spindle threads).
7. Carefully remove the outer wheel bearing; handle the bearings with clean, dry hands. Wrap the bearings in either clean oil-proof paper or lint-free rags.

NOTICE

Do not spin bearing rollers at any time. Dirt or grit can scratch the roller surface and cause rapid wear of the bearing assembly. Treat used bearings as carefully as new ones.

8. Remove the hub. Be careful not to damage the axle spindle threads as the assembly is removed.
9. Check the axle spindle for damage caused by a cocked bearing. The machined bearing surface on the spindle could be worn where the inner race of a bearing rotated on the spindle.

If spindle damage is found, contact Meritor at 866-668-7221 or www.meritor.com, **and** submit a WSC inquiry to the Warranty Campaigns department.

If no spindle damage is found, continue to the next step.

10. Using cleaning solvent, remove the old oil from the axle spindle.
11. Coat both bearing assemblies with fresh oil.

NOTICE

Use only fresh oil on the bearing assemblies; old oil could be contaminated with dirt or water (both are corrosives) and could cause damage to both wheel bearing assemblies and the wheel hub.

12. Wipe a film of axle oil on the axle spindle to prevent rust from forming behind the inner wheel bearing. Do not lubricate the seal journal.

NOTICE

When installing a hub, remember the following:

- **On vehicles equipped with WABCO ABS, use care when installing the hubs. To prevent damage to the tone wheel, do not drop the hub or lay it down in a way that would damage the tone wheel.**
- **Do not remove the outer wheel bearing once the hub is installed on the axle. Removing the outer bearing could cause the oil seal to become misaligned, which could cause damage to the wheel bearings, the hub, and the axle spindle.**

13. Mount the new hub assembly on the spindle.

June 2014
FL653A-C
NHTSA #13V-538 (FL653AB)
NHTSA 14V-242 (FL653C)
REVISED NOTICE

NOTICE

When opening the lock ring to install or remove it, use the tabs, and be careful not to deform it permanently. If the lock ring is damaged or bent, replace it with a new one.

NOTE: A new ConMet PreSet Plus hub has the lock ring pre-installed in the hub; it must be removed before the spindle nut is tightened.

14. If the lock ring is locked into the spindle nut, compress the tabs and pivot the ring to remove it from the nut. See **Fig. 6**.
15. Tighten the spindle nut 500 lbf-ft (678 N·m) while rotating the hub. Do not back off the spindle nut.
16. Install the lock ring, as follows.
 - 16.1 One of the holes in the face of the spindle nut will line up with a hole in the washer. Insert the lock tab of the lock ring through aligned holes.
 - 16.2 Using the tabs, seat the lock ring in the machined grooves of the spindle nut. See **Fig. 7**.

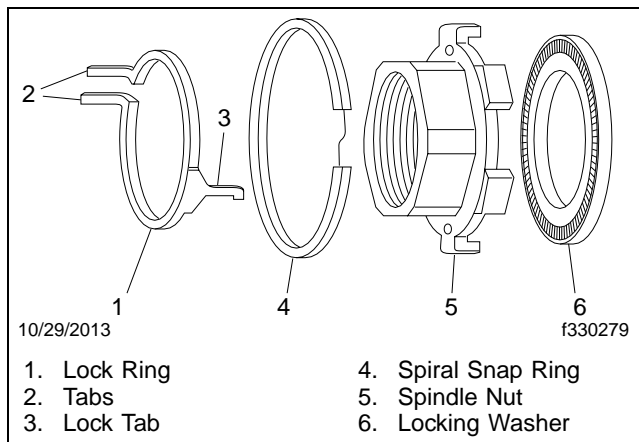

Fig. 6, PreSet Plus Spindle Nut System

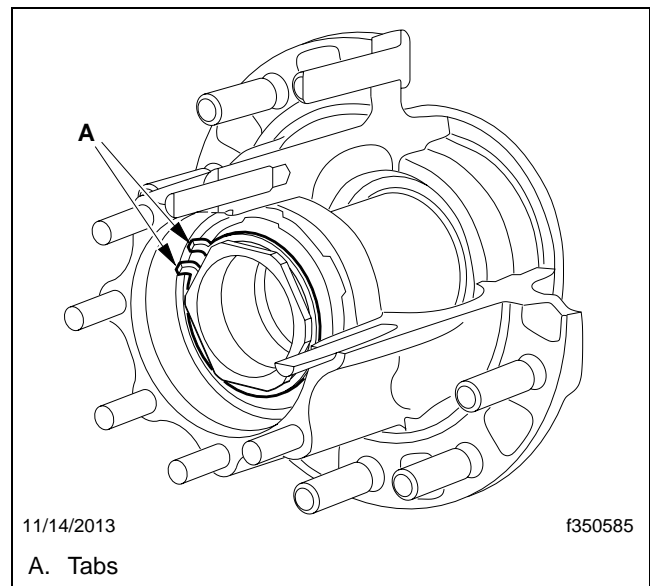

Fig. 7, Lock Ring, ConMet PreSet Plus Hub

17. Install a new gasket and the drive axle shaft. The splined end of the axle shaft must seat before the drive axle flange will fit over the studs.

June 2014
FL653A-C
NHTSA #13V-538 (FL653AB)
NHTSA 14V-242 (FL653C)
REVISED NOTICE

18. If needed, install the tapered dowels and washers on the drive axle studs. Install the drive axle stud nuts. Using the sequence shown in **Fig. 8**, tighten the nuts to the torque values given in **Table 5**.

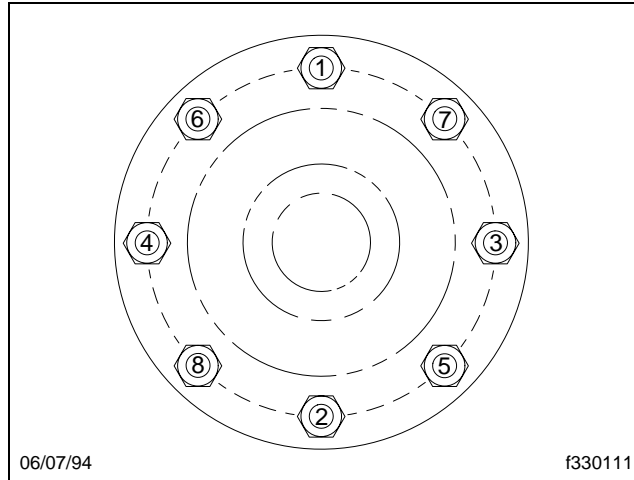

Fig. 8, Tightening Sequence, Drive Axle Stud Nuts

Torque Values, Drive Axle Stud Nuts		
Description	Size (grade 8)	Torque: lbf·ft (N·m)
With Dowels	5/8–18	130 to 140 (175 to 190)
Without Dowels	5/8–18	150 to 170 (203 to 230)

Table 5, Torque Values, Drive Axle Stud Nuts

19. Install the brake drum. For instructions, see **Section 35.01, Subject 160** in the *Cascadia Workshop Manual*.

⚠ WARNING

If the wheel nuts cannot be tightened to minimum torque values, the wheel studs have lost their locking ability, and the hub flange is probably damaged. In this case, replace it with a new wheel hub assembly. Failure to replace the wheel hub assembly when the conditions described above exist, could result in the loss of a wheel or loss of vehicle control, and possible personal injury and property damage.

20. Install the wheel and tire assembly. For instructions, see **Group 40** in the *Cascadia Workshop Manual*.

⚠ WARNING

Add oil to the axle housing bowl or the wheel hub after the drive axle shaft and wheel hub have been serviced. Failure to add oil will damage the wheel bearings and cause them to seize during vehicle operation. Seized bearing rollers can cause sudden damage to the tire or axle, possibly resulting in personal injury.

Recall Campaign

June 2014
FL653A-C
NHTSA #13V-538 (FL653AB)
NHTSA 14V-242 (FL653C)
REVISED NOTICE

21. Lubricate the wheel bearings, as follows.

IMPORTANT: When removing the fill port plug, make sure the rubber O-ring is attached to it and not stuck inside the fill port.

- 21.1 Clean the area surrounding the oil fill port plug, then remove the plug and O-ring.
- 21.2 Using a clean funnel, add 1.0 quart (0.95 liter) of the recommended drive axle lubricant through the oil fill port. For recommended lubricants, see **Table 6**.
- 21.3 Install the fill port plug, and tighten it 20 to 25 lbf·ft (27 to 34 N·m).

Meritor Drive Axle Recommended Lubricant			
Recommended Lubricant Type	Ambient Temperature	Lubricant SAE Viscosity Grade	Meritor Specification
Synthetic Gear Oil	-40°F (-40°C) and Up*	75W-90	0-76-N
	-40°F (-40°C) and Up	75W-140	0-76-M

* There is no upper limit on these outside temperatures, but axle sump temperature must never exceed 250°F (121°C).

Table 6, Meritor Drive Axle Recommended Lubricant

- 22. Adjust the rear axle brakes. For instructions, see **Group 42** in the *Cascadia Workshop Manual*.
- 23. Remove the safety stands, then lower the vehicle.
- 24. Clean a spot on the base label (Form WAR259). Write the campaign number, FL653, on a blank red completion sticker (Form WAR260) to indicate the work has been completed and attach it to the base label.