



Michael A. Berardi
Director
Service Engineering Operations
Ford Customer Service Division

Ford Motor Company
P. O. Box 1904
Dearborn, Michigan 48121

March 24, 2014

TO: All U.S. Ford and Lincoln Dealers

SUBJECT: STOP SALE / DEMONSTRATION / DELIVERY HOLD

Safety Recall 13S12 – Supplement #1

All 2013 Model Year Escape Vehicles Equipped with a 1.6L Engine

Risk of Localized Overheating of the Engine Cylinder Head that May Lead to Oil Leak Fires

REF: STOP SALE / DEMONSTRATION / DELIVERY HOLD

Dated January 23, 2014

New! REASON FOR THIS SUPPLEMENT

- *Announce that repair instructions and parts are available to repair vehicles.*
- *Provide information on seed stock and parts ordering.*
- *Allow additional labor without prior approval.*
- *Allow up to 2 rental days without prior approval.*
- *Provide details of Owner Letter mailings that will begin in April, 2014.*
- *Fuel Line Jumper Inspection OASIS Program Code 13Y03 will remain active for vehicles that require fuel line inspection of the installation performed during Safety Recall 12S35 (certain vehicles built on or before July 11, 2012).*
- *Claims for Program Code 13Y04 have been discontinued.*

AFFECTED VEHICLES

All 2013 model year Escape vehicles equipped with a 1.6L engine built at the Louisville Assembly Plant. Affected vehicles are identified in OASIS. In addition, for a list of vehicles assigned to your dealership, visit <https://web.fsavinlists.dealerconnection.com>. This information was made available on November 25, 2013.

New! REASON FOR THIS SAFETY RECALL

In all of the affected vehicles, localized overheating of the engine cylinder head may cause the cylinder head to crack causing an oil leak that may result in a fire in the engine compartment.

In a subset of the affected vehicles built through July 11, 2012; the service fuel line jumper installed during Safety Recall 12S35 may have been installed incorrectly. An improperly positioned fuel line jumper may chafe on other engine components over a period of time and leak fuel. A fuel leak in the presence of an ignition source may result in a fire.

New! SERVICE ACTION

Service parts and repair procedures are now available to address the concerns. Dealers will:

- Perform repairs following the technical information (Attachment III) that include enhancements to the engine shielding, cooling and control systems.
- If Program Code 13Y03 is open in OASIS, inspect the fuel line jumper for correct orientation and replace it only if it is not installed properly.

Additionally, some vehicles have been observed with an engine oil overfill condition that occurred during service when the oil capacity was not properly identified. A revised dip stick and label will be added to help proper maintenance and improve customer satisfaction.

- Replace the dipstick and add an identification label to the engine cover.

Prepare your dealership to efficiently perform the repair.

- Review the repair procedures which include 14 modular sub-procedures as identified in the technical information (Attachment III).
- Identify technician(s) to perform the repairs.
- Watch the instructional video and become familiar with the technical instructions and parts.
- Up to 2.0 hours additional actual time is authorized to assist with the initial repairs.

New! OWNER NOTIFICATION MAILING SCHEDULE

Owners will be notified via first-class mail beginning the week of April 7, 2014 that parts are now available and to contact their dealer to schedule repairs. Dealers should repair any affected vehicles that arrive at their dealership, whether or not the customer has received a letter.

PLEASE NOTE:

Federal law requires dealers to complete this recall service before a new vehicle is delivered to the buyer or lessee. Violation of this requirement by a dealer could result in a civil penalty of up to \$7,000 per vehicle. Correct all vehicles in your new vehicle inventory prior to delivery.

New! ATTACHMENTS

- Attachment I: Administrative Information
- Attachment II: Labor Allowances and Parts Ordering Information
- Attachment III: Technical Information – Overheat Repair and Dipstick Replacement
- Attachment IV: Technical Information – Inspection Check Sheet
- Attachment V: Technical Information – Fuel Line Jumper Inspection/Replacement
- Owner Notification Letters
- Video: Repair Overview & Procedure
- Dealer Q & A

QUESTIONS AND ASSISTANCE

Customer Service Manager (Dealer Assistance Only)	1-866-631-3788
Customer Relationship Center (Customer Assistance Only)	1-800-392-3673
Special Service Support Center (Dealer Assistance Only)	1-800-325-5621
Special Service Support Center (Parts Order Line Only)	1-800-207-2444

Sincerely,



Michael A. Berardi

STOP SALE / DEMONSTRATION / DELIVERY HOLD – Safety Recall 13S12 – Supplement #1

All 2013 Model Year Escape Vehicles Equipped with a 1.6L Engine

Risk of Localized Overheating of the Engine Cylinder Head that May Lead to Oil Leak Fires

New! OASIS ACTIVATED?

Yes, OASIS was activated on November 25, 2013.

Note: Vehicles that are open for Safety Recall 12S41 will be closed on March 24, 2014. Safety Recall 13S12 supersedes 12S41.

FSA VIN LIST ACTIVATED?

Yes, FSA VIN list was made available through <https://web.fsavinlists.dealerconnection.com> on November 25, 2013.

NOTE: Your FSA VIN list may contain owner names and addresses obtained from motor vehicle registration records. The use of such motor vehicle registration data for any purpose other than in connection with this recall is a violation of law in several states, provinces, and countries.

Accordingly, you must limit the use of this listing to the follow-up necessary to complete this recall.

CUSTOMER HANDLING

Some 2013 Escape owners may have experienced multiple recalls during their ownership experience. Based on this, there may be customers who require some extraordinary actions to be satisfied under the current situation. Ford has increased staff to assist you with customer handling. Contact your Customer Service Manager for customers requiring additional support:

- Call your Customer Service Manager directly at 1-866-631-3788, select 2 for dealership employees, enter P&A code, and select 1 to reach your Ford CSM, or
- Open an FMC360 case for your customer that will automatically be directed to your facing Customer Service Manager (CSM). The CSM will contact you within 2 hours to discuss the customer's unique handling requirements.

NOTE: We are NOT advising customers to stop driving their vehicles at this time. An improved control system was implemented both in production and in the field through the November 2012 recall (12S41) to reduce the potential for severe engine overheats, to detect severe overheats earlier, and to warn the driver to 'stop safely now.'

STOCK VEHICLES

- Correct all affected units in your new vehicle inventory before delivery.
- Use OASIS to identify any affected vehicles in your used vehicle inventory.

SOLD VEHICLES

- Owners of affected vehicles will be directed to dealers for repairs.
- Correct other affected vehicles identified in OASIS which are brought to your dealership.

TITLE BRANDED / SALVAGED VEHICLES

- Affected title branded and salvaged vehicles are eligible for this recall.

STOP SALE / DEMONSTRATION / DELIVERY HOLD – Safety Recall 13S12 – Supplement #1

All 2013 Model Year Escape Vehicles Equipped with a 1.6L Engine

Risk of Localized Overheating of the Engine Cylinder Head that May Lead to Oil Leak Fires

New! RELATED DAMAGE

Related damage identified during the inspection in Procedure B does not require prior approval from the Special Service Support Center. Follow the claiming instructions in this bulletin for related damage.

New! ADDITIONAL LABOR TIME

- *Based upon the complexity of the repair, dealers are authorized to claim up to 2.0 hours actual time without contacting the Special Service Support Center for approval.*
- *Follow the Actual Time Usage Guidelines and Service Management Responsibilities as identified in the Warranty and Policy Manual.*
- *If you encounter aftermarket equipment or modifications to the vehicle which might prevent the repair of the covered condition, call the Special Service Support Center.*

OWNER REFUNDS

Refunds are not authorized for this program.

New! RENTAL VEHICLES

Ford Motor Company will pay for up to two (2) days of vehicle rental. Follow Extended Service Plan (ESP) guidelines for dollar amounts. The daily rate can include applicable taxes but is not allowed to exceed the stated daily rate. Rental will only be reimbursed for the day(s) the vehicle is at the dealership for repair. Prior approval for more than two (2) rental days is required from the Special Service Support Center (1-800-325-5621).

SPECIAL HANDLING ALLOWANCE (Customer Vehicles Only)

After FSA repairs are completed on a vehicle, dealers will be provided an allowance to:

- Wash and vacuum the customer's vehicle,
- Top off the fuel tank, and/or
- Provide vehicle pick-up and/or delivery *or cover additional rental expense exceeding ESP guidelines.*

Dealers will be authorized to claim up to \$75 to cover a combination of the above special handling actions as they choose.

STOP SALE / DEMONSTRATION / DELIVERY HOLD – Safety Recall 13S12 – Supplement #1

All 2013 Model Year Escape Vehicles Equipped with a 1.6L Engine

Risk of Localized Overheating of the Engine Cylinder Head that May Lead to Oil Leak Fires

New! CLAIMS PREPARATION AND SUBMISSION

Note: If 13Y03 is open in OASIS, the vehicle requires two separate claims to complete the repair.

Repair Claims for Program Code 13S12

- *Enter claims using Direct Warranty Entry (DWE).*
- *Refer to ACESII manual for claims preparation and submission information.*
- *Labor operations 13S12D and 13S12E must be submitted on an FSA claim using Program Code 13S12.*
- *An initial supply of twenty-five (25) ZC-31-B Motorcraft Metal Surface Prep Wipes has been provided in the dealer kit. If additional quantities are required, claim 1 wipe per repair.*
- *Claim Related Damage and Additional Labor Time using Program Code 13S12 on a repair line that is separate from the repair line on which the FSA is claimed with the related damage flag checked.*
 - *For related damage use the published labor operation for the repair. If no labor operation exists for the part that was replaced / repaired, include the base part number along with "MT." (Example: base part number 8522, claim as actual time "MT8522")*
 - *For additional labor time claim as actual time up to 2.0 hours using "MT13S12".*
- *For rental vehicle claiming, follow Extended Service Plan (ESP) guidelines for dollar amounts. Enter the total amount of the rental expense under Miscellaneous Expense code "RENTAL". Rental for more than two (2) days requires prior approval.*
- *For Special Handling items (customer vehicles only), claim up to a maximum combined value of \$75. All Special Handling claims must be on the same repair line using Program Code 13S12.*
 - *Wash/Vacuum: Enter Miscellaneous Expense Code "SCHP".*
 - *Misc. Expense Code: SCHP*
 - *Misc. Expense Amount: Total amount*
 - *Fuel Fill: Enter Miscellaneous Expense Code "FUEL".*
 - *Misc. Expense Code: FUEL*
 - *Misc. Expense Amount: Total amount*
 - *Vehicle Pick-up/Delivery or Additional Rental Expense Exceeding ESP Guidelines: Enter Miscellaneous Expense Code "SCHP".*
 - *Misc. Expense Code: SCHP*
 - *Misc. Expense Amount: Total amount*

STOP SALE / DEMONSTRATION / DELIVERY HOLD – Safety Recall 13S12 – Supplement #1

All 2013 Model Year Escape Vehicles Equipped with a 1.6L Engine

Risk of Localized Overheating of the Engine Cylinder Head that May Lead to Oil Leak Fires

New! CLAIMS PREPARATION AND SUBMISSION (Continued)**New! Fuel Line Inspection Claims Using Program Code 13Y03****(Only Certain Vehicles built on or before July 11, 2012)**

- Labor operations 13S12A and 13S12B must be submitted on an FSA claim using Program Code 13Y03.
- Related damage for fuel line jumper inspection and or replacement must be claimed on a repair line that is separate from the repair line on which the FSA is claimed using Program Code 13Y03. Related damage requires prior approval from the Special Service Support Center.
- "MT" labor related to fuel line replacement should be submitted on a separate repair line with the related damage flag checked. "MT" labor for Program Code 13Y03 requires prior approval from the Special Service Support Center.
- *Rental and Special Handling claims for program code 13Y03 have been discontinued. These expenses will not be accepted for 13Y03 repairs dated after March 26, 2014.*

New! Cooling System Pressure Test, Repair, and Fill Claims Using Program Code 13Y04

- *Claims for program code 13Y04 have been discontinued and will not be accepted with a repair order dated after March 26, 2014.*
- Labor operation 13S12C must be submitted on an FSA claim using Program Code 13Y04.
- Related damage for any coolant leaks found must be claimed on a repair line that is separate from the repair line on which the FSA is claimed using Program Code 13Y04. Related damage for Program Code 13Y04 does not require prior approval from the Special Service Support Center.
- "MT" labor should be submitted on a separate repair line. "MT" labor for Program Code 13Y04 does not require prior approval from the Special Service Support Center.

NOTE: Maintain supporting documentation for all Miscellaneous Expenses according to procedure as identified in the Warranty and Policy Manual. Include receipts for miscellaneous expenses documented in service file.

STOP SALE / DEMONSTRATION / DELIVERY HOLD – Safety Recall 13S12 – Supplement #1

All 2013 Model Year Escape Vehicles Equipped with a 1.6L Engine

Risk of Localized Overheating of the Engine Cylinder Head that May Lead to Oil Leak Fires

New! LABOR ALLOWANCES**All Vehicles**

Description	Labor Operation	Labor Time
<i>Perform Engine Shielding, Cooling System, Dipstick, and Control System Updates.- Vehicles built on or before April 19, 2013 (Includes Thermostat Replacement)</i>	13S12D	6.1 Hours
<i>Perform Engine Shielding, Cooling System, Dipstick, and Control System Updates.- Vehicles built on or after April 20, 2013 (Does <u>Not</u> Include Thermostat Replacement)</i>	13S12E	5.1 Hours

Labor Operations for Fuel Line Jumper – Vehicles with OASIS Program Code 13Y03

Description	Labor Operation	Labor Time
Inspect Fuel Line Jumper Installation – Inspection PASSED	*13S12A	0.2 Hours
Replace Fuel Line Jumper – Inspection FAILED	*13S12B	0.5 Hours

***NOTE: Labor operations 13S12A and 13S12B are only applicable to certain vehicles built on or before July 11, 2012 and identified by OASIS Program Code 13Y03.**

STOP SALE / DEMONSTRATION / DELIVERY HOLD – Safety Recall 13S12 – Supplement #1
 All 2013 Model Year Escape Vehicles Equipped with a 1.6L Engine
 Risk of Localized Overheating of the Engine Cylinder Head that May Lead to Oil Leak Fires

New! PARTS REQUIREMENTS / ORDERING INFORMATION

<i>Part Number</i>	<i>Description</i>	<i>Quantity</i>
*DJ5Z-8522-A	Water Bypass Kit	1
*DJ5Z-6750-B (or DJ5Z-6750-A)	Oil Level Indicator Kit	1
PM-4-A or PM-4-B CPM-4-B (Canada)	Motorcraft Metal Brake Parts Cleaner	1
VC-3DIL-B (US) CVC-3DIL-B (Canada)	Motorcraft Orange Antifreeze / Coolant Prediluted	1 Gallon
ZC-31-B	Motorcraft Metal Surface Prep Wipes (25 per container)	1 Wipe

* To manage part availability, dealers must use the web link below to access the 13S12 part availability Web Tool. This link will allow dealers to submit orders for these parts to the Special Service Support Center.

<https://www.techhotline.dealerconnection.com/dealerpa/Lookup13S12Data.aspx>

Note: The Web Tool will allow orders for one set of kits per VIN and provide notification if quantities become too low.

One-time Seed Stock

Water Bypass Kit (DJ5Z-8522-A) and Oil Level Indicator Kits (DJ5Z-6750-B) will be seed stocked the week of March 24, 2014. Dealers with 20 or more VINS assigned to their dealership will receive a quantity equal to approximately 10% of the vehicles assigned. All other dealers will receive one set of kits.

STOP SALE / DEMONSTRATION / DELIVERY HOLD – Safety Recall 13S12 – Supplement #1

All 2013 Model Year Escape Vehicles Equipped with a 1.6L Engine

Risk of Localized Overheating of the Engine Cylinder Head that May Lead to Oil Leak Fires

New! PARTS REQUIREMENTS / ORDERING INFORMATION (Continued)**Parts Table for Fuel Line Jumper – Vehicles with OASIS Program Code 13Y03 Open and FAILED Inspection**

Part Number	Description	Quantity
**CV6Z-9J280-G	Fuel Line Jumper	1 (Only required if inspection failed)

**To manage part availability; based upon the small number of expected failures, dealers must contact the Special Service Support Center Parts Order Line at 1-800-207-2444 to order a Fuel Line Jumper (if required).

When calling to place an order for a Fuel Line Jumper, please be prepared to provide dealer P&A code, VIN, RO# and Vehicle Mileage.

Dealers will be notified via a DOES II communication if circumstances warrant a change in part supply strategy and when open ordering resumes. All other parts requirements should be ordered through normal order processing channels.

Questions regarding parts should be directed to the Special Service Support Center Parts Order Line (1-800-207-2444) or E-mailed to: Ford@Renkim.com.

The DOR/COR number for this recall is 50532.

DEALER PRICE

For latest prices, refer to DOES II.

PARTS RETENTION AND RETURN

Follow the provisions of the Warranty and Policy Manual, Section 1 "WARRANTY PARTS RETENTION AND RETURN POLICIES."

EXCESS STOCK RETURN

Excess stock returned for credit must have been purchased from Ford Customer Service Division in accordance with Policy Procedure Bulletin 4000.

ALL 2013 MODEL YEAR ESCAPE VEHICLES EQUIPPED WITH A 1.6L ENGINE — RISK OF OVERHEATING THAT MAY RESULT IN ENGINE FIRES

OVERVIEW

Safety Recall 13S12 applies to 2013 Model Year Escape models equipped with a 1.6L engine due to potential localized overheating of the engine cylinder head. The localized overheating may cause the engine cylinder head to crack, causing an oil leak that may result in a fire in the engine compartment. Repairs include enhancements to the engine shielding system, engine cooling system, and engine control systems. Additionally, some vehicles have been observed with an engine oil overfill condition that occurred during service when the oil capacity was not properly identified. An improved dip stick and label will be added to facilitate proper maintenance and improve customer satisfaction.

Due to the complexity of this repair, the following has been done to make the repair procedure go as smoothly as possible:

- Repair procedures have been divided alphabetically into 14 separate procedures.
- Parts have been packaged into three kits.
 - Water bypass kit (-8522-) with parts required to repair one vehicle. Parts in the kit are further packaged in bags and labeled for the procedures that they are used.
 - Oil level indicator assembly (-6750-) (Dipstick and label kit).
 - Dealer kit containing: 12.5 mm (0.5 in) material hole punch (100-D702), Motorcraft® ZC-31B towelettes, PM-13-A rust preventative. These components are used for multiple vehicles.
- Each procedure includes:
 - Overview
 - List and photo of the parts required
 - List of unique tools needed
 - Service tips to help complete the repair

NOTE: Please read this procedure in its entirety, prior to performing repairs. Additionally a video is available to assist.

SERVICE PROCEDURE

Procedure A - Initial Disassembly and Preparation for Inspection

OVERVIEW: This procedure details the components to be removed to enable initial vehicle inspection.

PARTS / SUPPLIES REQUIRED: None

UNIQUE TOOL REQUIREMENTS: None

SERVICE TIPS: Please note the following:

- The Inspection / Check Sheet (Attachment IV) must be printed and started during "Procedure A".
- The air cleaner, mass air flow sensor and air intake tube are removed as an assembly.
- Cover the turbocharger inlet opening to prevent dropping any parts or debris into the turbocharger while the turbocharger inlet pipe is off.



1. Print a copy of the Inspection / Check Sheet (Attachment IV), to record vehicle information and inspection/repair information for the vehicle. The Inspection / Check Sheet is to be attached/filed with the recall repair order following completion, it does not need to be provided to Ford at this time.

2. Fill out top of Inspection / Check Sheet including:

- VIN
- Technician ID
- Repair Order Number
- Repair Date
- Vehicle Mileage
- Vehicle Build Date
- Open Recalls

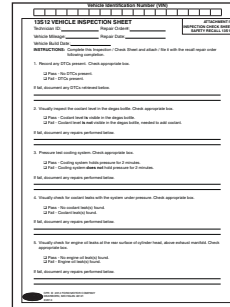

3. Using OASIS, document vehicle build date on the Inspection / Check Sheet.

- Vehicles built on or before April 19, 2013 will require Procedure H - Thermostat Replacement.
- Check OASIS for 13Y03 or other open FSA(s).

4. With the vehicle in NEUTRAL, position it on a hoist. For additional information, refer to Workshop Manual (WSM) Section 100-02.

5. Using IDS/scan tool, retrieve and record DTCs on the Inspection / Check Sheet.

- Any DTCs recorded will be used later in this procedure.

6. Remove the engine appearance cover.

7. Remove the cowl panel. For additional information, refer to WSM Section 501-02.



All Vehicles

NOTICE: When working with liquid or vapor tube connectors, make sure to use compressed air to remove any foreign material from the connector retaining clip area before separating from the tube or damage to the tube or connector retaining clip can occur. Apply clean engine oil to the end of the tube before inserting the tube into the connector.

NOTICE: Whenever turbocharger air intake system components are removed, always cover open ports to protect from debris. It is important that no foreign material enter the system. The turbocharger compressor vanes are susceptible to damage from even small particles. All components should be inspected and cleaned, if necessary, prior to installation or reassembly.

8. Disconnect the EVAP line quick connect coupling from the air intake tube center section. Set the clip aside for re-installation to prevent it from falling into the engine compartment. See Figure A1.
9. Loosen the clamp and disconnect the air intake tube from the turbocharger inlet pipe. See Figure A1.

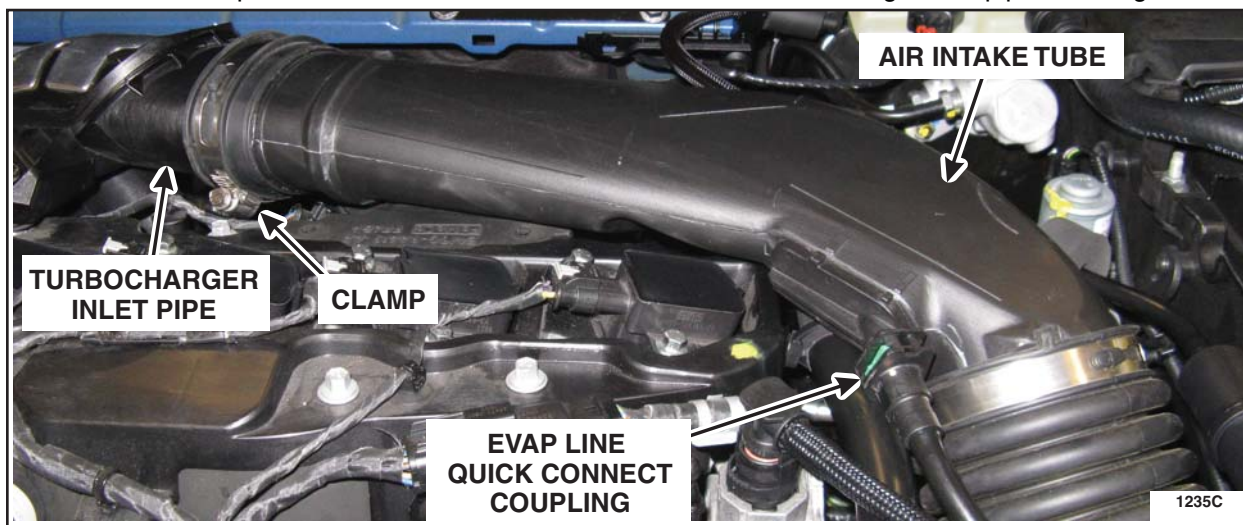

FIGURE A1



NOTE: The air cleaner assembly is removed from the vehicle with the mass air flow sensor and air intake tube attached.

10. Remove the air cleaner assembly. See Figure A2.

- a. Disconnect the mass air flow sensor electrical connector.
- b. Release the fresh air intake tube flap.
- c. Detach the mass air flow sensor wire harness retainer from the air cleaner assembly.
- d. Lift upward to disengage the two retaining grommets and remove the air cleaner assembly.

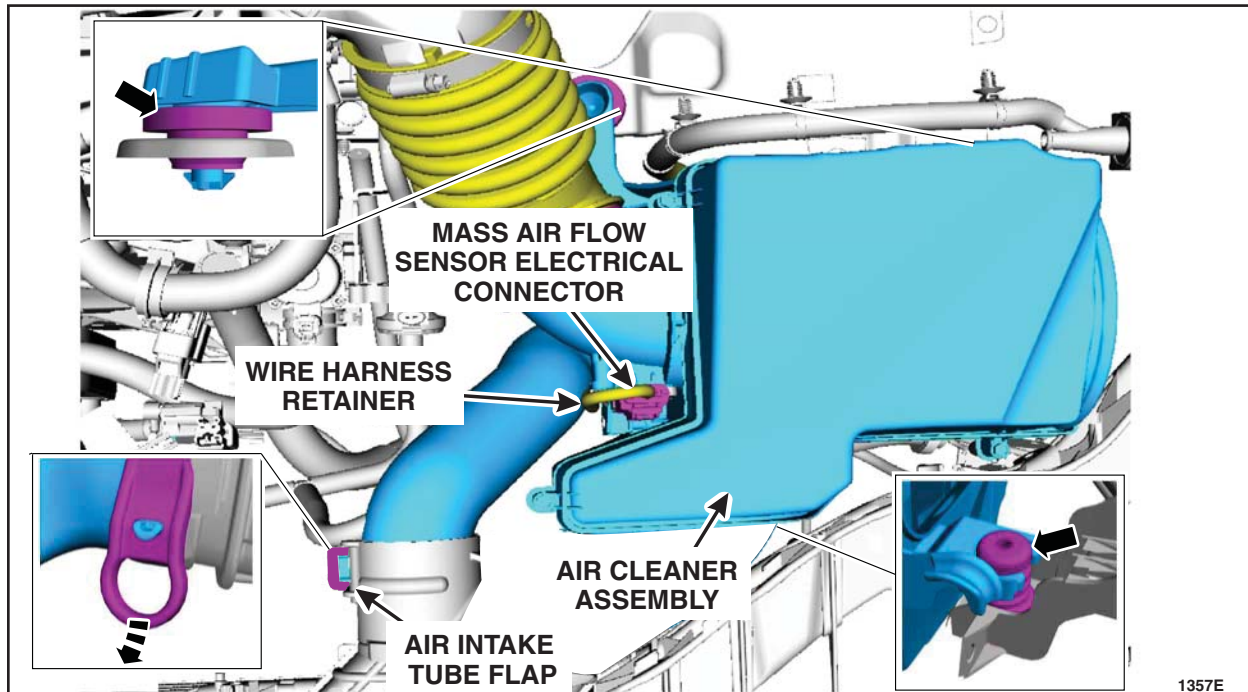

FIGURE A2

11. Remove the battery tray. For additional information, refer to WSM Section 414-01.

- The air cleaner assembly was removed previously.



NOTICE: Whenever turbocharger air intake system components are removed, always cover open ports to protect from debris. It is important that no foreign material enter the system. The turbocharger compressor vanes are susceptible to damage from even small particles. All components should be inspected and cleaned, if necessary, prior to installation or reassembly.

12. Disconnect the PCV tube from the turbocharger inlet pipe. Remove the retainers and loosen the clamp at the turbocharger. Remove the turbocharger inlet pipe. See Figure A3.

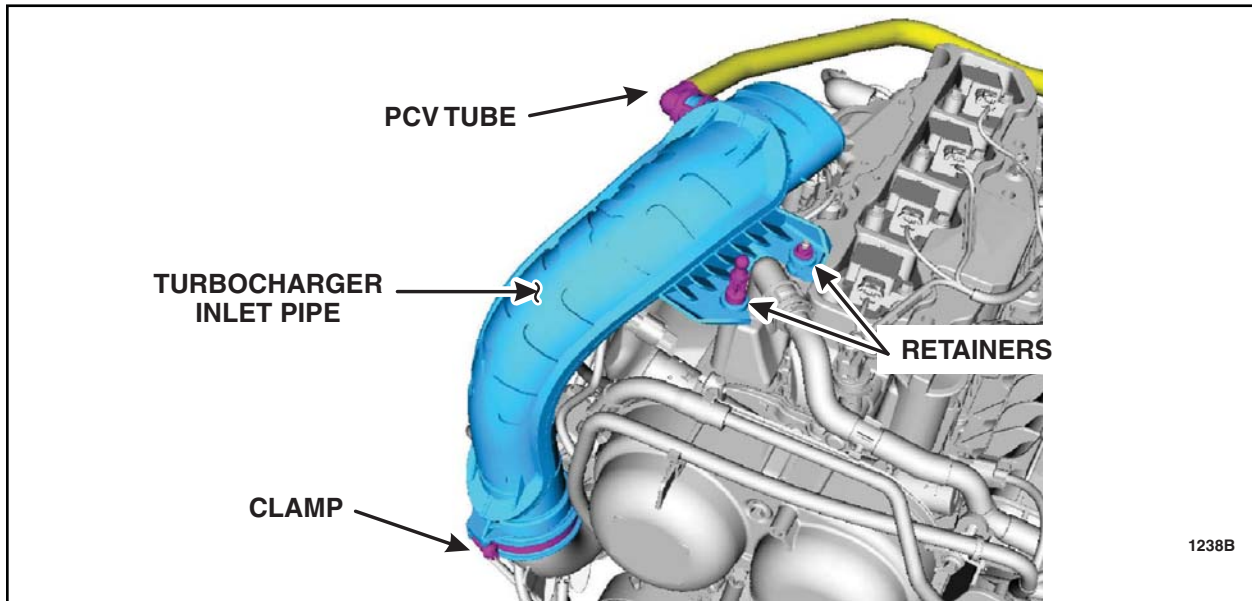

FIGURE A3

13. Remove the retainers and the front underbody air deflector. See Figure A4.

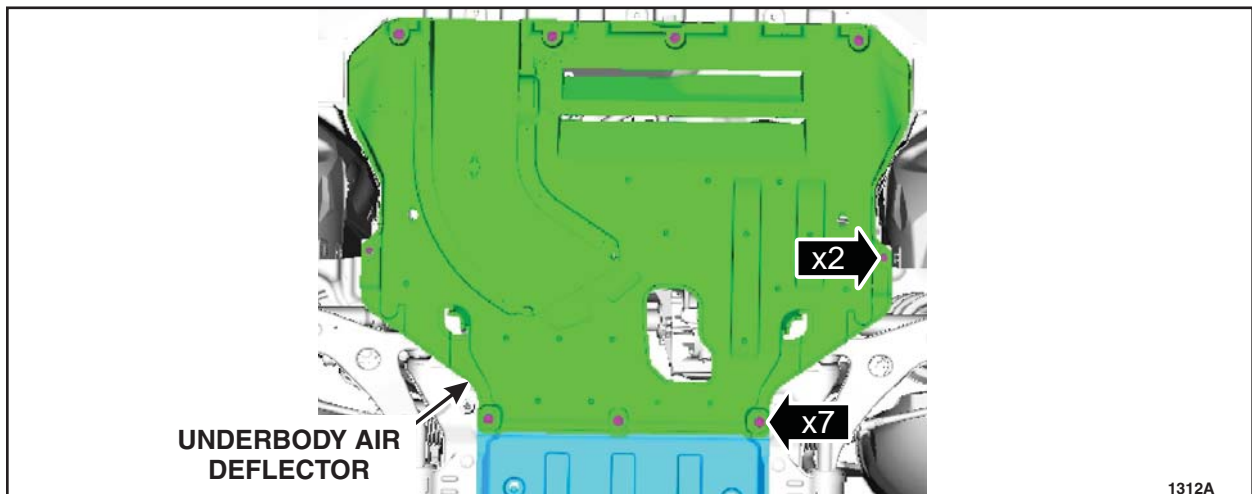

FIGURE A4



Procedure B - Inspection / Check Sheet Completion

OVERVIEW: The Inspection must be completed and documented on the Inspection / Check Sheet. The inspection will check for obvious issues that require correction with additional focus on cooling system issues such as:

- Coolant loss
- External coolant leaks
- Any DTC(s) that could indicate overheating or are a result of internal engine damage that resulted from a previous cooling system failure.

PARTS / SUPPLIES REQUIRED: None

UNIQUE TOOL REQUIREMENTS: Rotunda Cooling System Pressure Tester (STN12270) and a commercially available adapter (Snap-On TA52, AST ASSFZ-47, Redline RDL95-0750 or equivalent).

SERVICE TIPS: Use standard Workshop Manual and PC/ED Diagnostics, if necessary, to diagnose any cooling system or misfire DTC(s) retrieved and for any unexplained loss of coolant issues.

NOTE: Perform a quick underhood visual inspection for any obvious coolant, oil, transmission, or fuel leaks.

NOTE: Repair any issues found before proceeding. If the coolant pressure test identifies issues with the degas bottle, turbocharger return tube, upper section of the degas bottle return hose, or quick connect T-fitting at the coolant shutoff solenoid valve; note the condition. These items will be replaced as part of this recall.

Vehicle Inspection

1. Visually inspect the coolant level in the degas bottle.

- If the coolant level **is** visible in the degas bottle, proceed to Step 2.
- If the coolant level **is not** visible in the degas bottle, add coolant as necessary, and proceed to Step 2.

NOTE: Any gross loss of coolant must be identified and repaired prior to proceeding.

2. Remove the degas bottle cap.

3. Install a coolant pressure tester with adapter onto the degas bottle. Pressurize to 138 kPa (20 psi). Once stabilized, pressure should hold at 138 kPa (20 psi) for a minimum of 2 minutes.

- If pressure test fails, the source of pressure loss must be identified and repaired as necessary before proceeding.

4. Visually check for coolant leaks with the system under pressure.

5. Check the engine oil level to ensure it is within normal range, note if it is overfilled. Visually check for engine oil leaks at the rear surface of cylinder head, above exhaust manifold, that may be the result of a crack in the cylinder head.



6. DTCs - Note and identify the cause of the following potential DTCs before proceeding:

Cooling System DTCs	
P0217	Engine Coolant Over Temperature Condition
P0218	Transmission Fluid Over Temperature Condition
P0219	Engine Over Speed Condition
P1299	Cylinder Head Over Temperature Protection Active
Engine Misfire DTCs	
P0300	Random Misfire Detected
P030x	Cylinder X Misfire Detected
P0313	Misfire Detected With Low Fuel
P0316	Misfire Detected On Startup (First 1000 Revolutions)

7. Note any issues and/or repairs made on the Inspection / Check Sheet.



Procedure C - Cast Engine Shield Installation

OVERVIEW: The *new* cast engine shield is installed on the back of the cylinder head to deflect an oil leak caused by engine overheating.

PARTS / SUPPLIES REQUIRED:

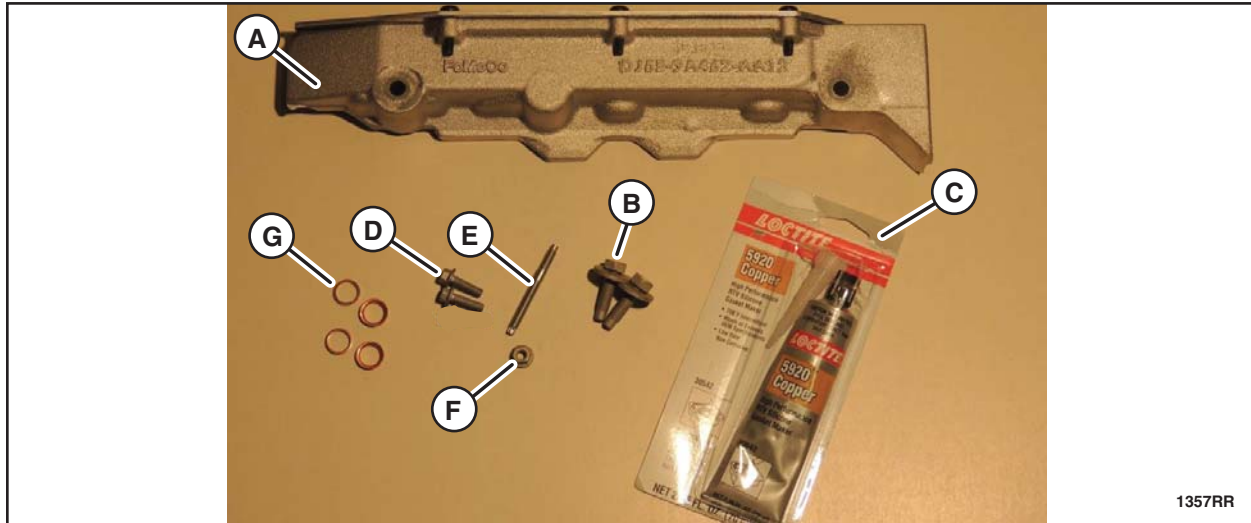

1357RR

A	Cast Engine Shield Assembly
B	Cast Engine Shield Mounting Bolts (2 ea.)
C	LOCTITE® #5920 Copper RTV Silicone
D	Heat Shield Attaching Bolts (2 ea.)
E	Heat Shield Stud
F	Heat Shield Stud Nut (1 ea.)
G	Turbocharger Coolant Inlet/Outlet Banjo Fitting Copper Washers (2 ea. Flat, 2 ea. Rolled)
H	Motorcraft® ZC-31B Towelette (1 ea.) (Supplied in Dealer Kit) (Not Shown)
I	Motorcraft® Metal Brake Parts Cleaner (PM-4-A or PM-4-B) (Dealer Procured) (Not Shown)

UNIQUE TOOL REQUIREMENTS: None

SERVICE TIPS: Follow all installation steps and torque sequences in this procedure in the order provided to ensure the *new* cast engine shield and the exhaust manifold heat shield align properly for fastener installation.



NOTE: On some vehicles, the coolant may have a green appearance, especially on a black background. This is a normal condition due to the addition of a dye during vehicle assembly. Motorcraft® orange antifreeze/coolant is used in all 2013 Escape applications.

1. Drain the cooling system. For additional information, refer to WSM Section 303-03A.
2. Remove and discard the turbocharger coolant return tube. See Figure C1.
 - a. Disconnect the turbocharger coolant return tube from the degas bottle.
 - b. Detach the clip from the coolant return tube.
 - c. Release the clamp, remove and discard the coolant return tube.

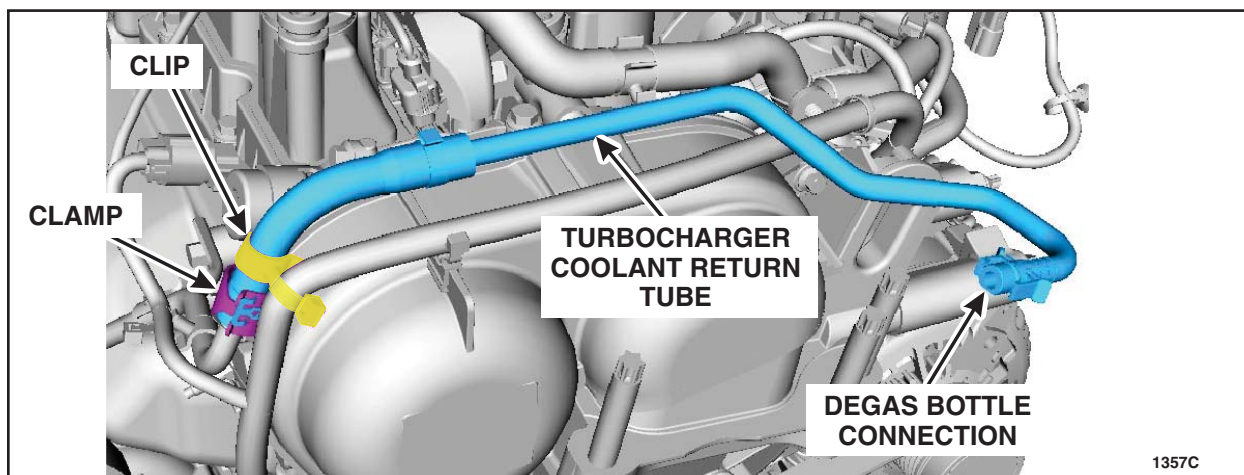

FIGURE C1

NOTE: Once the turbocharger coolant inlet and outlet tubes are removed, ensure that the banjo bolt copper washers do not remain on the turbocharger.

3. Remove the turbocharger coolant inlet and outlet tube bracket bolts. See Figure C2.
 - Discard the turbocharger outlet tube bolt.
 - The inlet tube bracket bolt will be reused during reassembly.

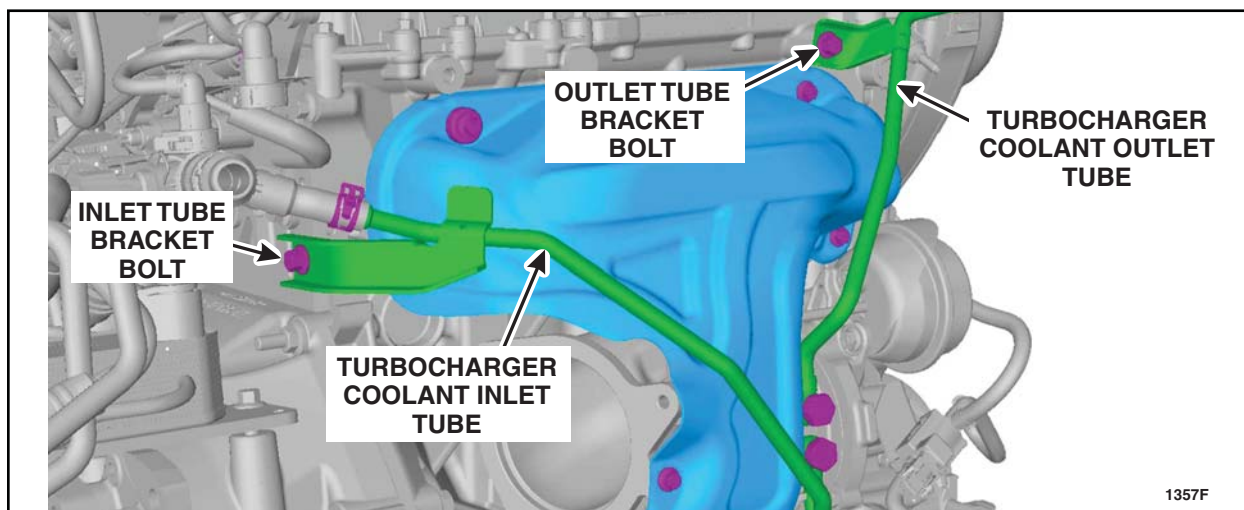

FIGURE C2



NOTICE: Be careful to not touch or damage the surface of the banjo fittings while removing the copper washers from the banjo bolts.

4. Remove the banjo bolts and the turbocharger coolant outlet tube. Position aside the turbocharger coolant inlet tube. See Figure C3.

- Discard both copper washers after removal.
- If required, use a pair of needle nose pliers to hold the copper washers while turning the banjo bolt to thread the washer off of the bolt.

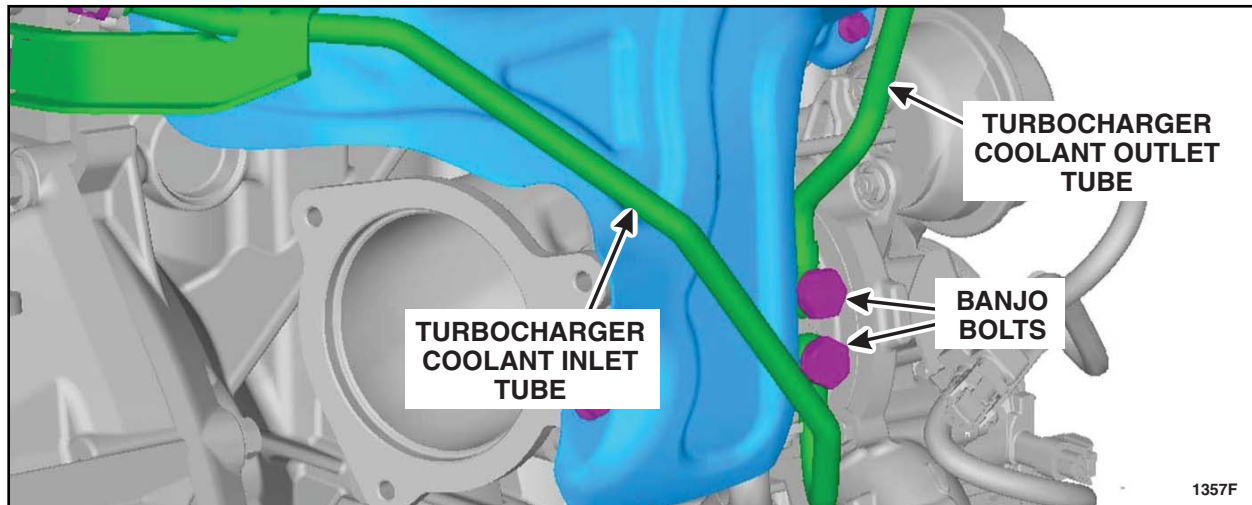

FIGURE C3

5. Remove the four (4) bolts and the exhaust manifold heat shield. See Figure C4.

- Do not discard the bottom heat shield bolt. It will be reused during assembly.

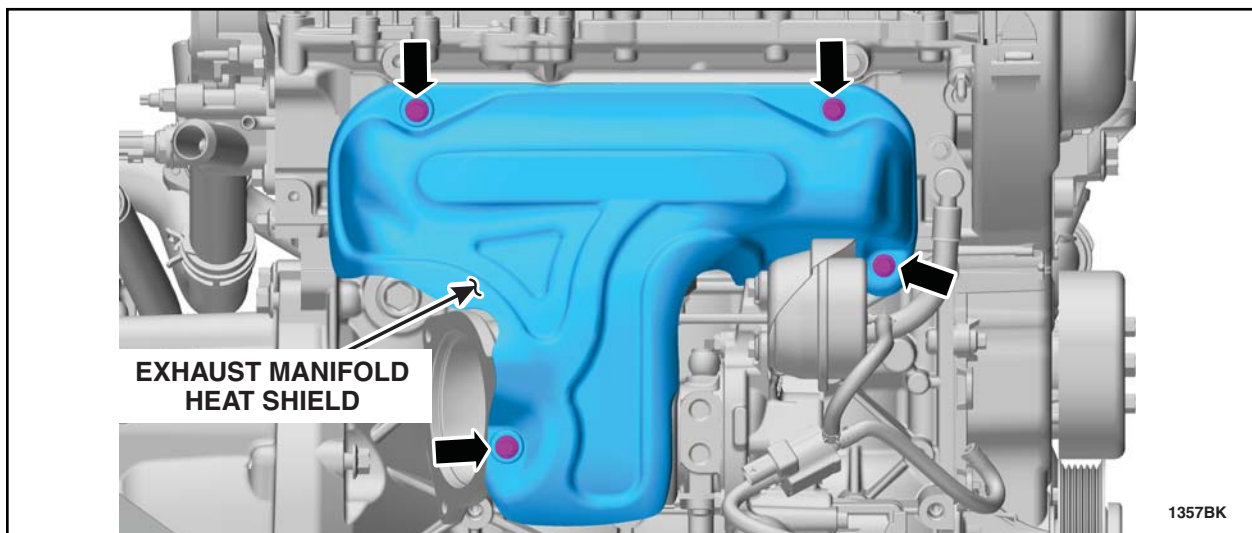

FIGURE C4



6. Prepare the cylinder head for the *new* cast engine shield installation. See Figure C5.
- a. Spray and wipe down the rear of the cylinder head using Motorcraft® Metal Brake Parts Cleaner (PM-4-A or PM-4-B).
 - Repeat this step a second time and ensure the surface is oil free.
 - Blow dry using compressed air to remove any puddles.
 - b. Using one (1) towelette from the Motorcraft® ZC-31B (Bonderite 1455) canister, wipe the rear of the cylinder head in the area shown. This etches the aluminum to allow proper bond with the LOCTITE® 5920 copper RTV silicone.

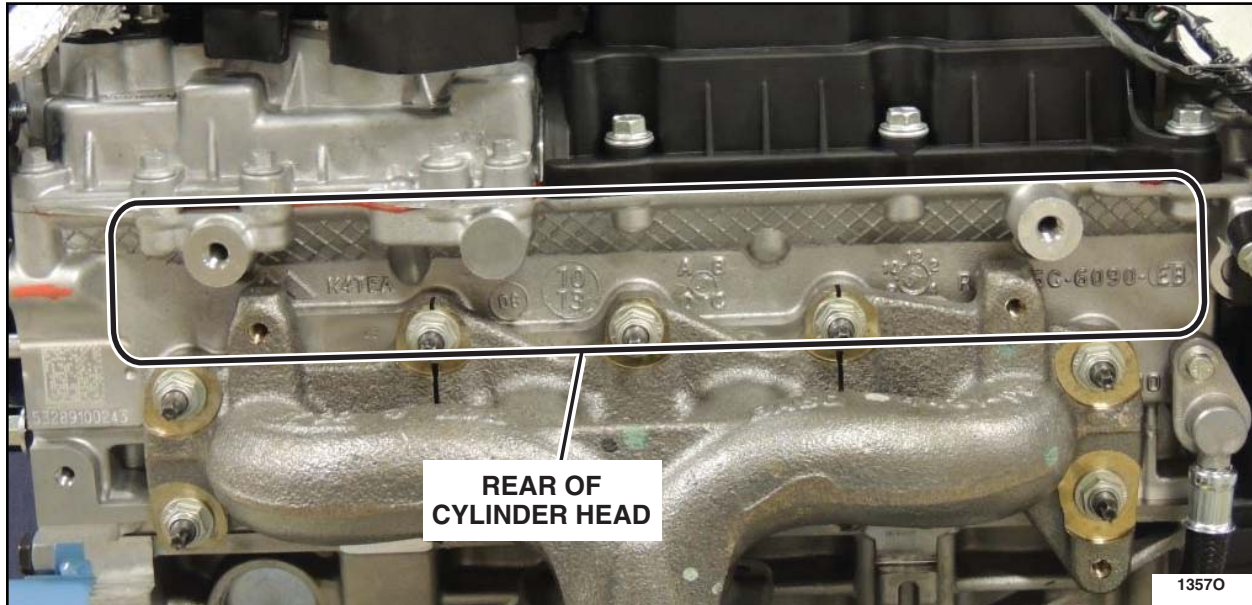

FIGURE C5

NOTICE: Ensure that the *new* cast engine shield stays clean and free from any dirt or vehicle fluids. Any contamination may result in failure of the new engine oil shield to seal to the engine.



NOTE: Moisture curing begins immediately after the product is exposed to the atmosphere, therefore parts to be assembled should be mated within a few minutes after the product is dispensed. After the product is applied "Procedure C" should be completed within 20 minutes.

7. Apply two (2) 3 mm to 5 mm beads of LOCTITE® 5920 copper RTV silicone (approximately 1/2 tube) that is supplied in the vehicle parts kit to the *new* cast engine shield. See Figure C6.

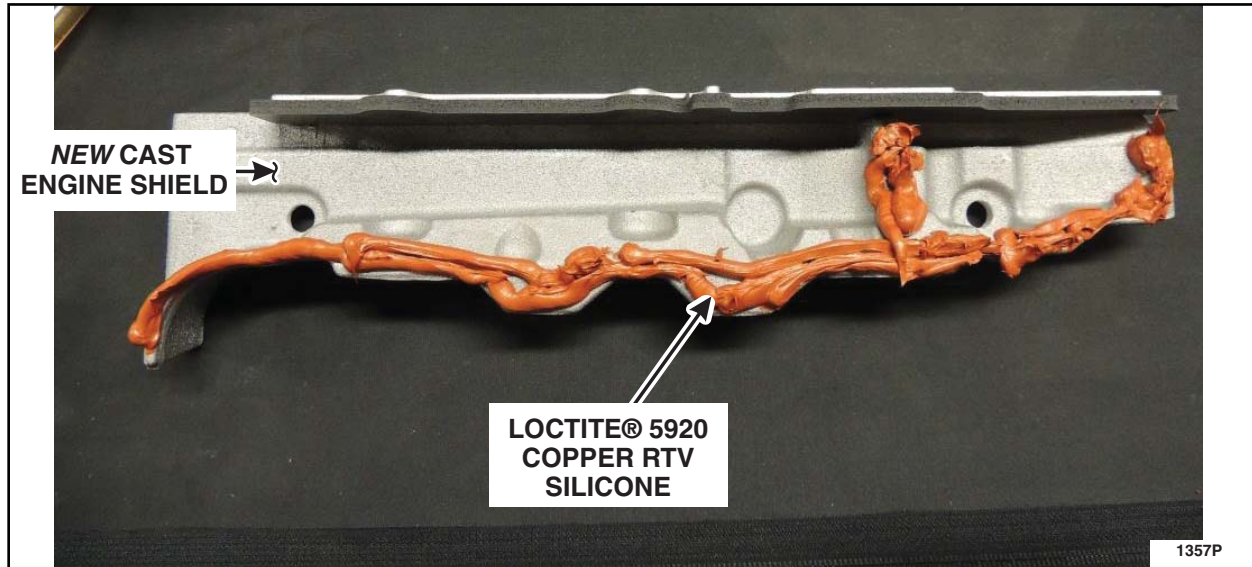

FIGURE C6

8. Carefully position the *new* cast engine shield to the rear of the cylinder head and install the *new* driver's side bolt finger tight. The LOCTITE® patch on the bolt will only allow you to install it a few threads. See Figure C7.

- Do not fully tighten the bolt at this time.



FIGURE C7



9. Install the *new* heat shield stud at the upper driver's side exhaust manifold heat shield bolt location. See Figure C8.

- Tighten to 10 Nm (89 lb-in).

NOTE: Ensure the *new* heat shield stud is installed onto the exhaust manifold as shown. Do not install onto the engine. See Figure C8.

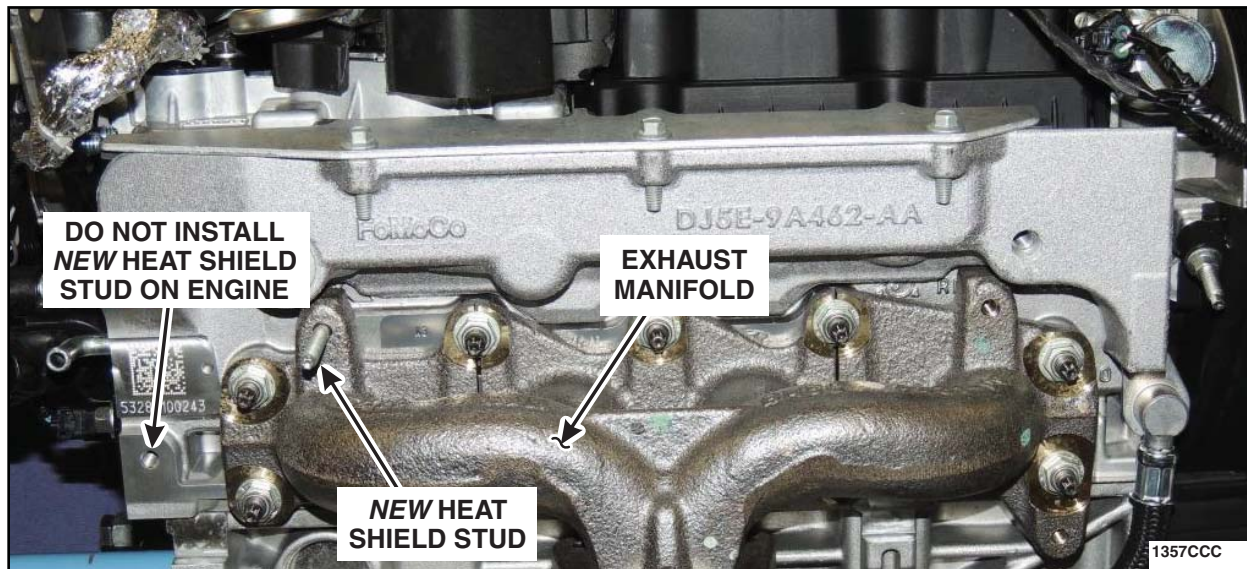

FIGURE C8

10. While holding the heat shield in position, loosely install the previously removed exhaust heat shield bottom bolt. Do not attempt to secure the upper portion of the heat shield into place until the bottom bolt is started into the threads on the turbocharger housing boss. See Figure C9.

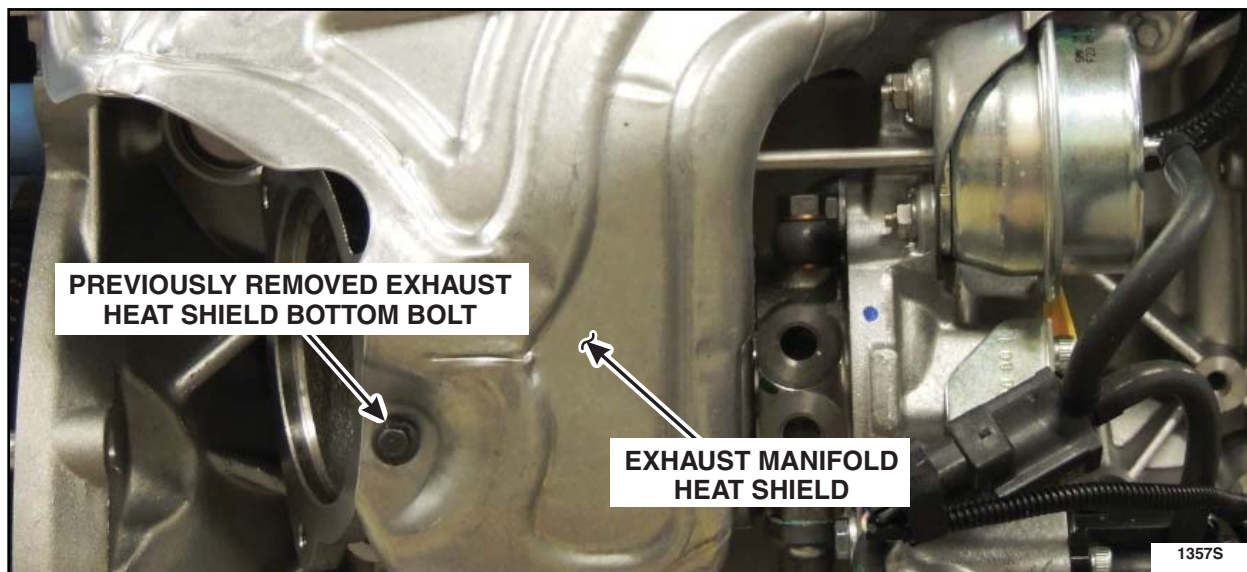

FIGURE C9



NOTE: When re-installing the exhaust manifold heat shield, first install the bolt at the lower turbocharger boss loosely, then push down on the top of the heat shield to fit it over the stud installed at the upper left side, then pull it toward the front of the vehicle tight up under the lip of the cast engine shield. Use an inspection mirror to identify any areas where the shield might get hung up on installation.

11. While pressing downward, position the exhaust heat shield onto the new heat shield stud and under the RH side of the *new* cast engine shield. See Figure C10.

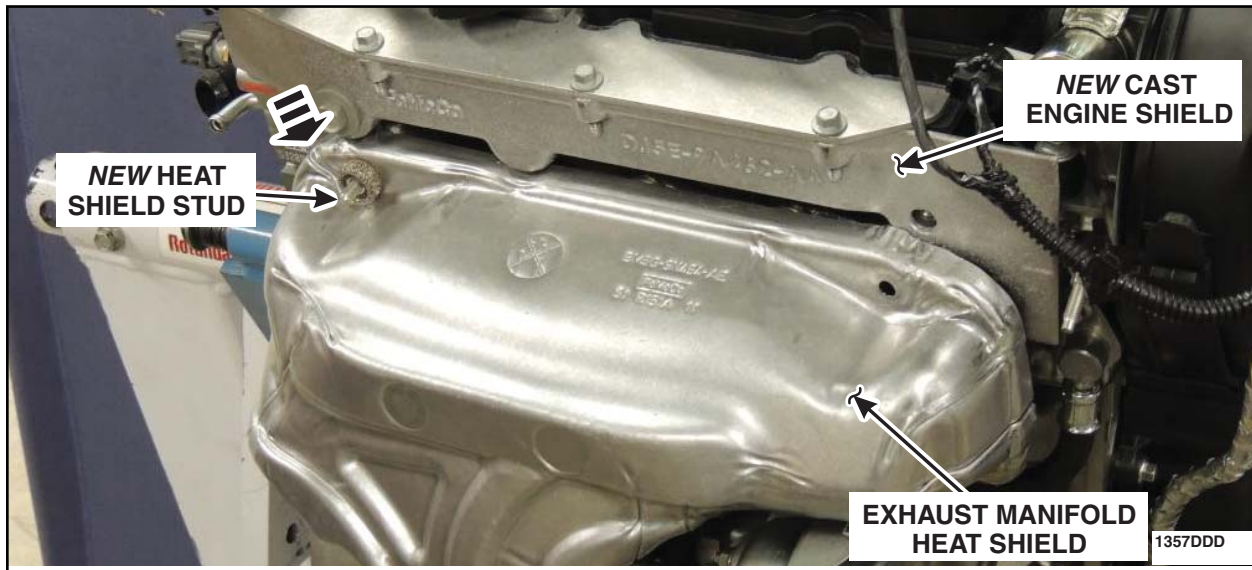

FIGURE C10

12. Continue to press downward and pull forward to roll the exhaust manifold heat shield under the *new* cast engine shield. See Figure C11.

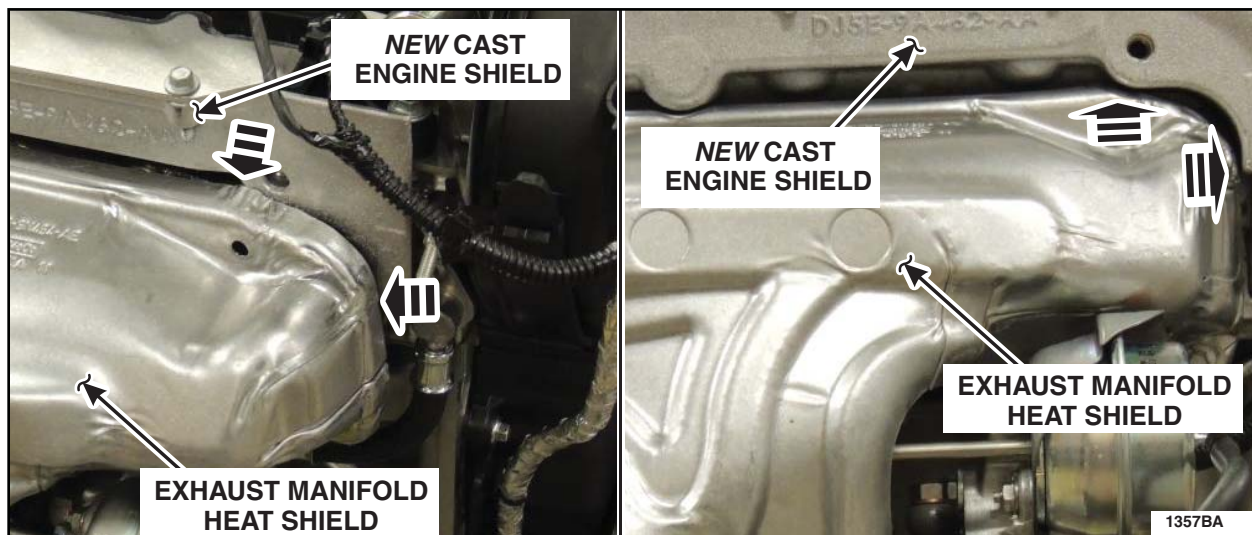

FIGURE C11



13. Install the two (2) *new* bolts and *new* heat shield stud nut onto the exhaust manifold heat shield.
See Figure C12.

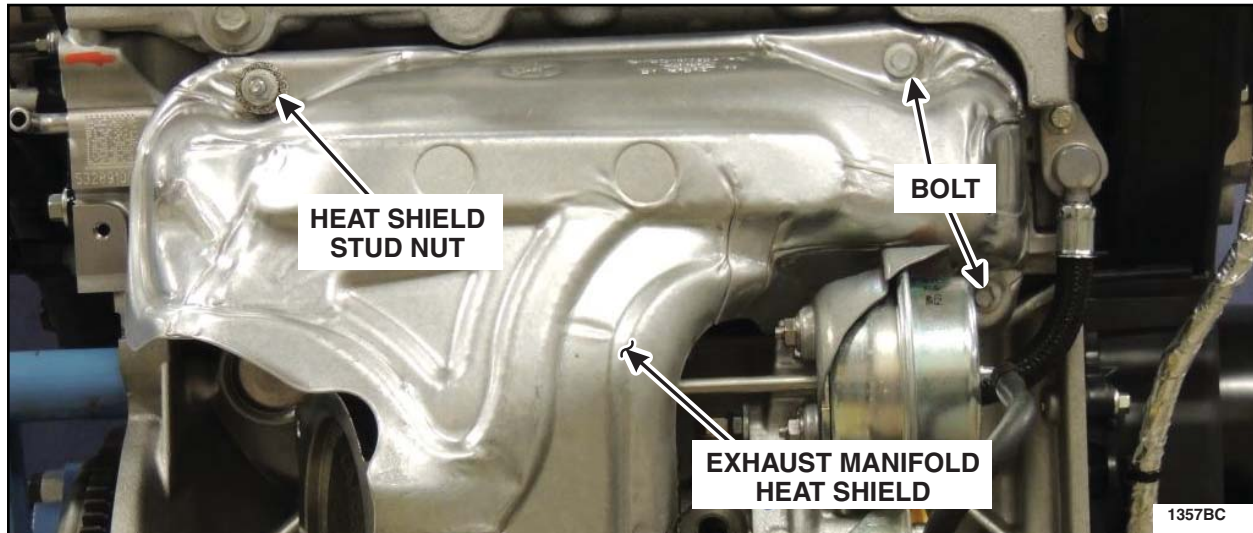

FIGURE C12

14. Tighten the four (4) exhaust manifold heat shield retainers to 10 Nm (89 lb-in).
See Figures C9 and C12.

NOTE: When reinstalling the turbocharger inlet and outlet coolant tubes, the *new* banjo bolt copper washers must be installed as follows: See Figure C13.

- The rolled compression copper washer should be installed between the turbocharger inlet and outlet coolant tubes and the turbocharger.
- The flat copper washer should be installed between the banjo bolt head and the turbocharger inlet and outlet coolant tubes.

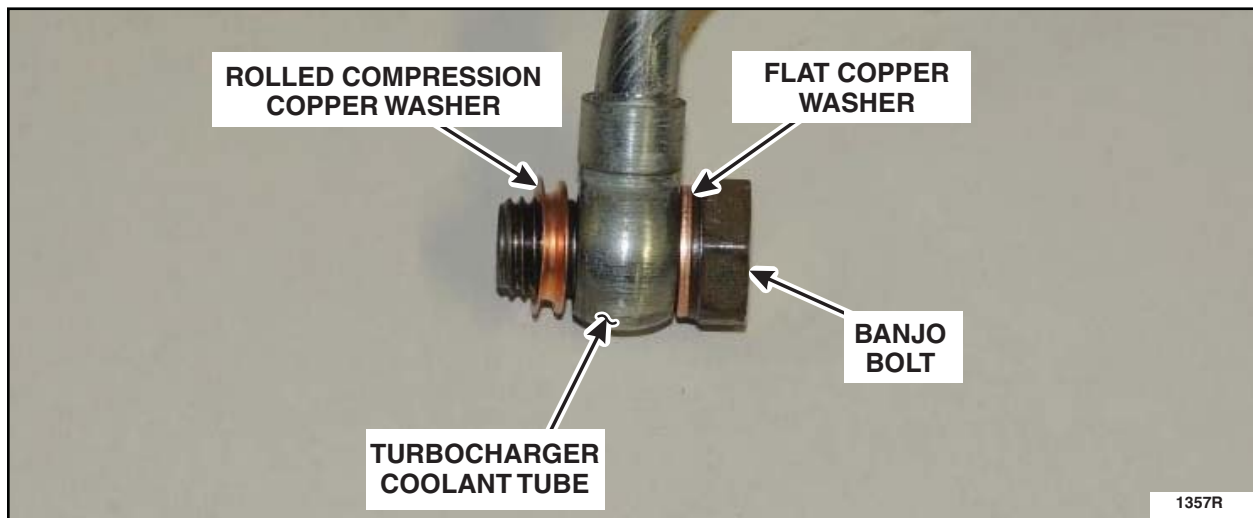

FIGURE C13



15. Install the vehicle parts kit supplied banjo bolt copper washers and the banjo bolts onto the turbocharger coolant inlet and outlet tubes. See Figure C13.
16. Loosely install the turbocharger coolant inlet and outlet tubes and banjo bolts onto the turbocharger. See Figure C3.
17. Loosely install the coolant inlet tube bracket bolt. See Figure C2.
18. Loosely install the remaining *new* cast engine shield bolt. This bolt also will retain the turbocharger coolant outlet tube bracket. See Figure C14.
19. Tighten the turbocharger coolant inlet and outlet tube banjo bolts to 28 Nm (21 lb-ft). See Figure C3.
20. Tighten both *new* cast engine shield bolts to 28 Nm (21 lb-ft). See Figure C14.

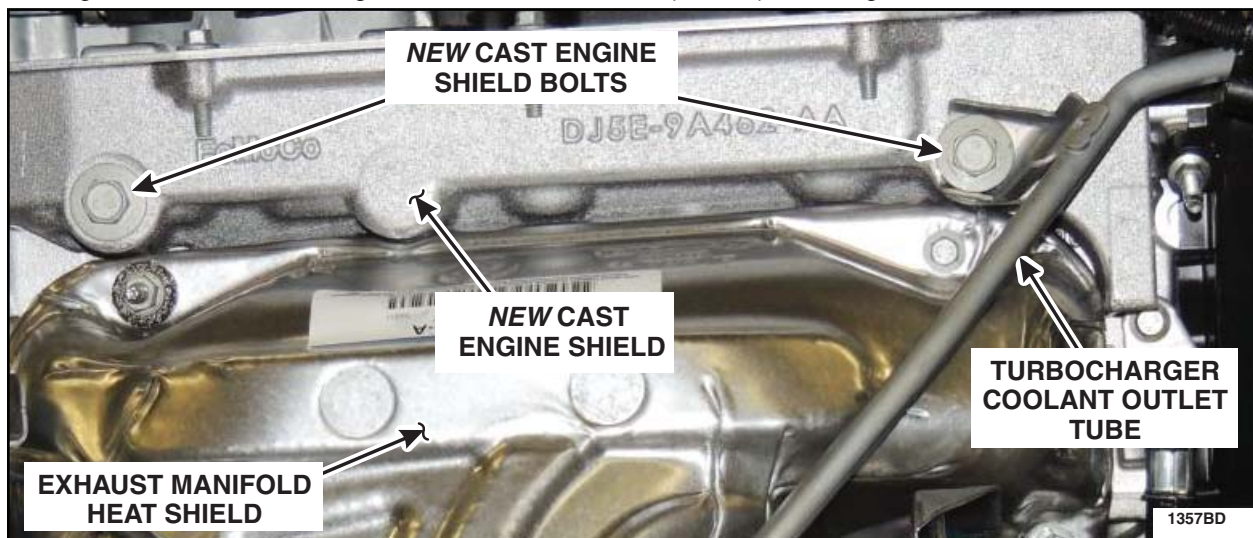

FIGURE C14

21. Tighten the coolant inlet tube bracket bolt to 23 Nm (17 lb-ft). See Figure C2.



Procedure D - Battery Tray Modification

OVERVIEW: The battery tray is removed and four holes are drilled in the right side to allow mounting of wiring harness components that will be added to support coolant level monitoring. The battery is reinstalled to allow Instrument Panel Cluster (IPC) programming, while additional repairs are performed.

PARTS / SUPPLIES REQUIRED:

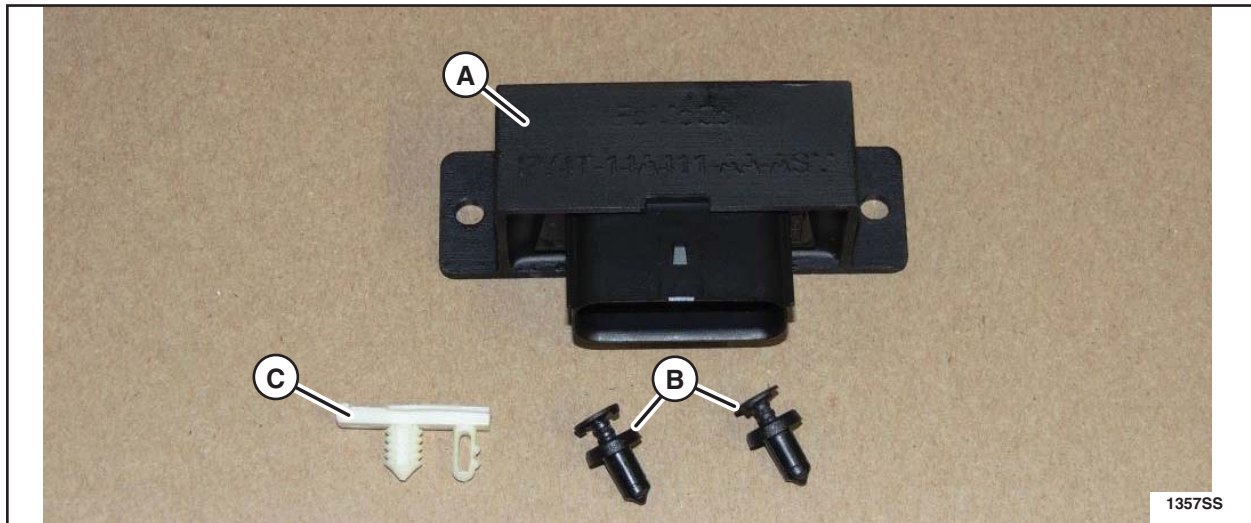

A	Connector Junction Box
B	Push Pin Retainers (2 ea.)
C	Wiring Harness Clip

UNIQUE TOOL REQUIREMENTS: 5.5 mm (7/32" / 0.21 in), 6.3 mm (1/4" / 0.25 in) drill bits.

SERVICE TIPS: Remove the two (2) push pin retainers from the connector junction box, prior to installation. While installing the connector junction box ensure that the push pin retainers are installed in the proper orientation. See Figure D4.



1. Using the dimensions shown below, mark and drill the locations of the two (2) holes that are required for the new connector junction box, in the right side of the battery tray. See Figure D1.
 - a. Position the *new* connector junction box on the forward right side of the battery tray, 10mm (0.39 in) down from the top edge of the battery tray. Using the *new* connector junction box as a template, mark the two (2) hole locations on the battery tray. See Figure D1.
 - b. Remove the *new* connector junction box from the battery tray.
 - c. Using a 6.3 mm (1/4" / 0.25 in) drill bit, drill the two marked locations on the battery tray.

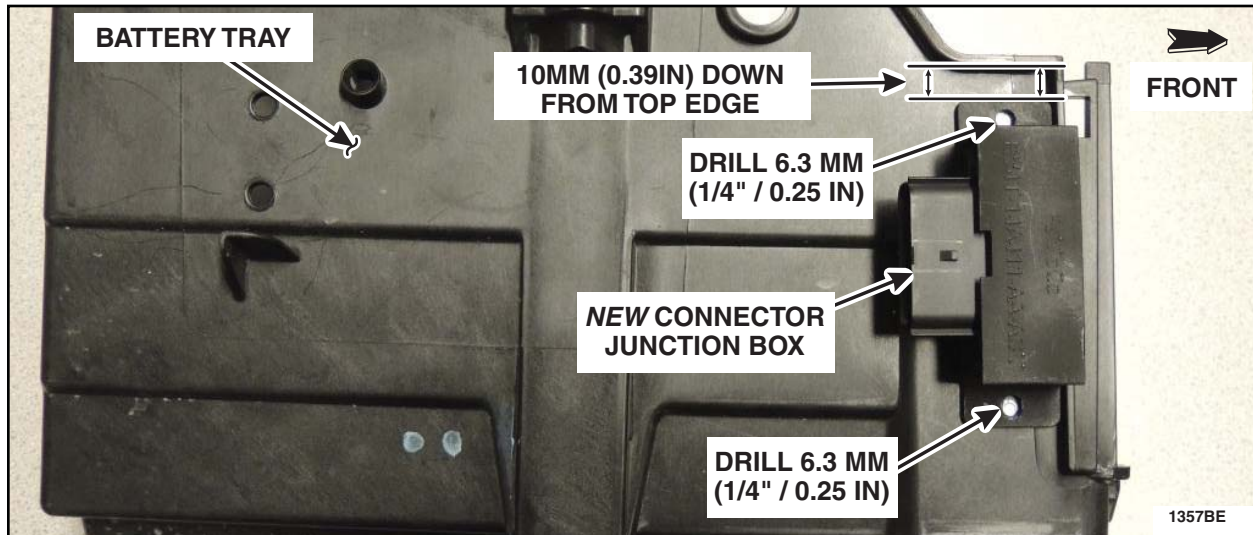

FIGURE D1

2. Measure and mark the two hole locations on the battery tray for the *new* wire harness clip. See Figure D2.

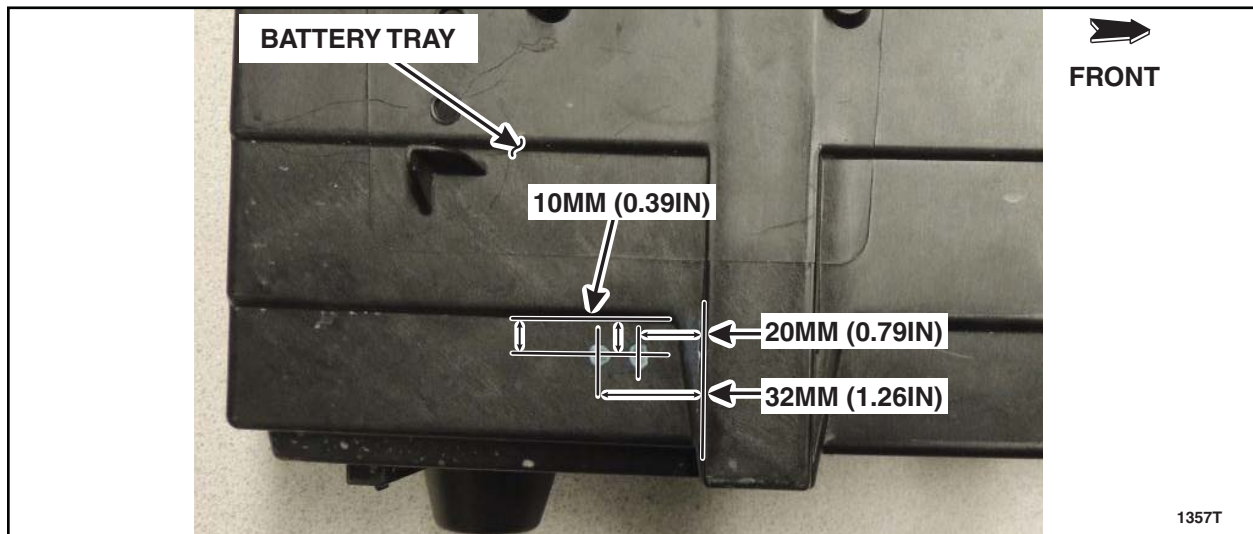

FIGURE D2



- Using the appropriate size drill bit for two (2) remaining marked locations on the battery tray, 5.5 mm (7/32" / 0.21 in) and 6.3 mm (1/4" / 0.25) as indicated in Figure D3, drill the two (2) holes. See Figure D3.

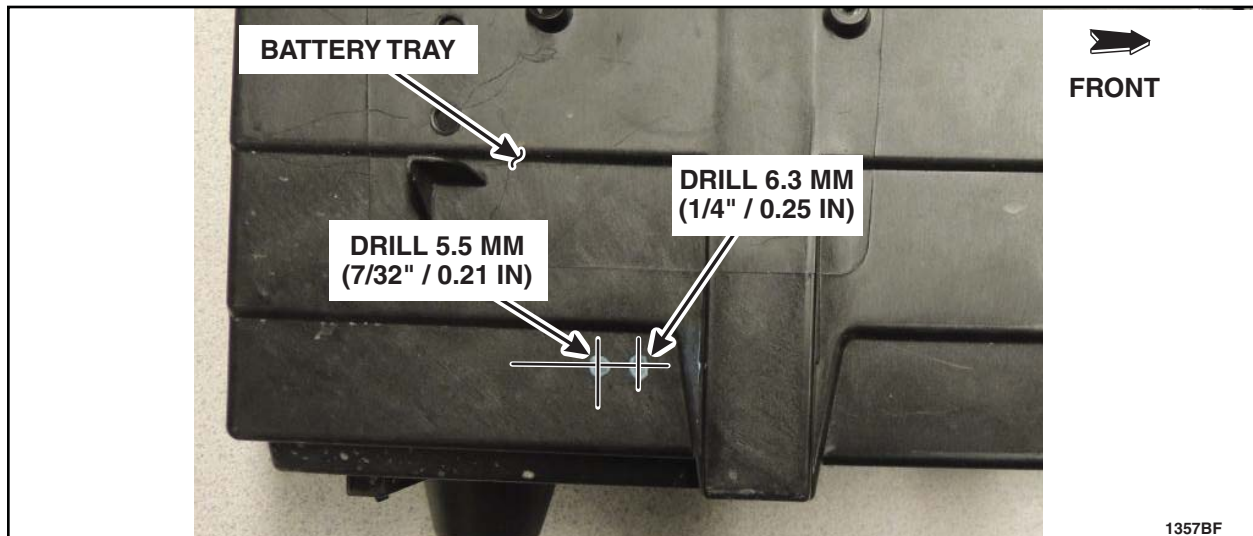

FIGURE D3

- Deburr the four (4) previously drilled holes on the battery tray as necessary.
- Attach the *new* connector junction box to the battery tray using the two (2) *new* push pin retainers. Install the *new* push pin retainers so the heads of the retainers are on the **inside** of the battery tray. See Figure D4.
- Install the *new* wire harness clip onto the battery tray. The christmas tree portion of the *new* wire harness clip is to be installed into the larger of the two mounting holes. See Figure D4.

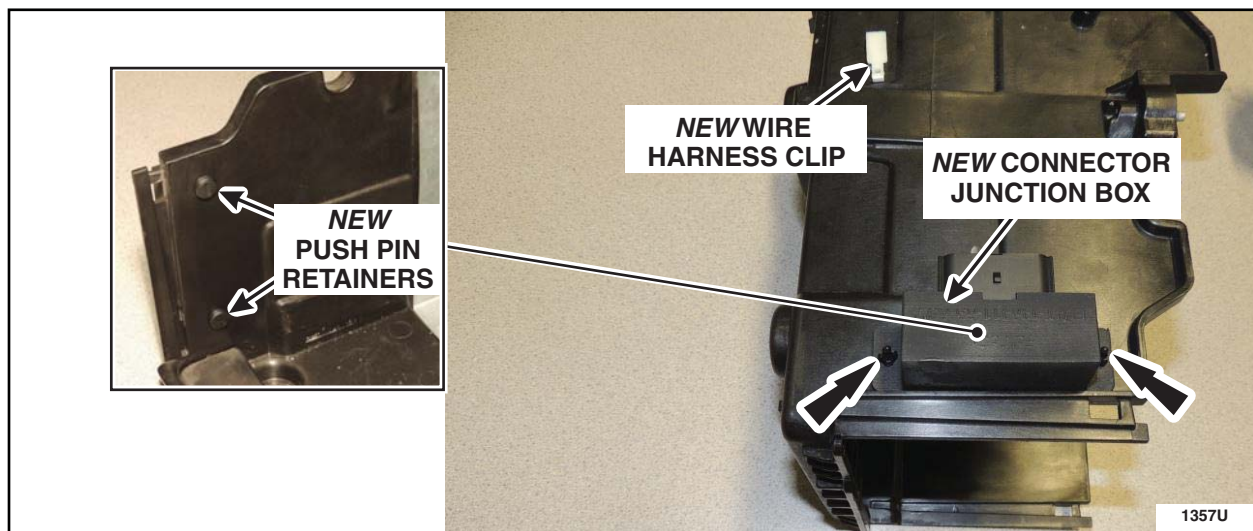

FIGURE D4



7. Position the battery tray back into the vehicle and install the three (3) bolts. See Figure D5.

- Tighten to 11 Nm (97 lb-in).

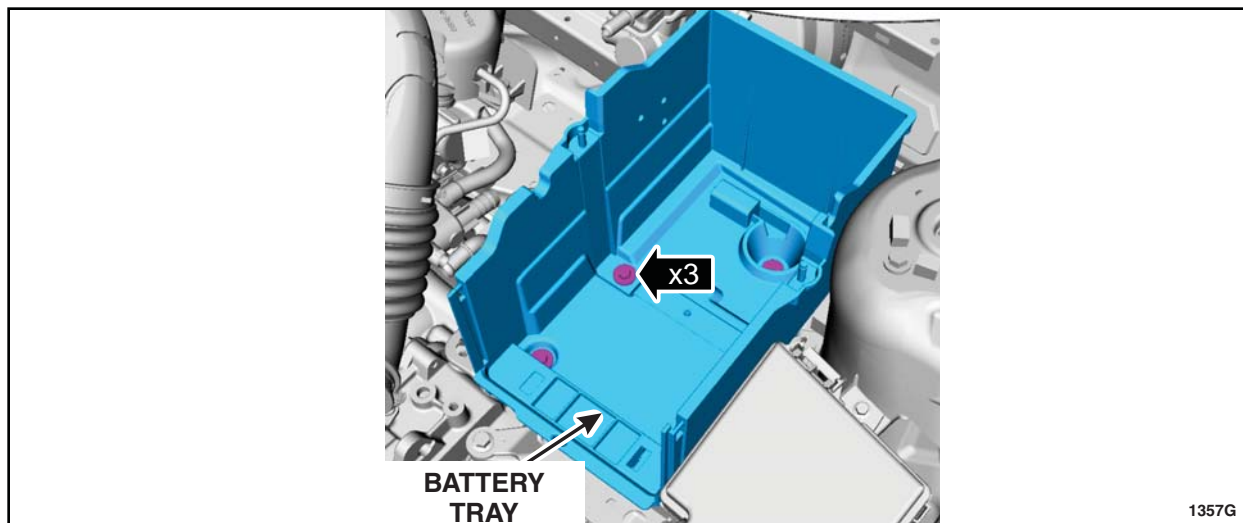

FIGURE D5

Vehicles built on or before April 19, 2013

8. Install and connect the battery. For additional information, refer to WSM Section 414-01.

- Do not connect the battery cable to ground at this time.
- Do not reinstall the engine air cleaner assembly at this time. It will be installed in one of the following procedures.
- Do not attach the transmission fluid heater coolant control valve to the battery tray at this time. See Figure E5.

9. Remove the nut and disconnect the battery B+ terminal cable. See Figure D6.

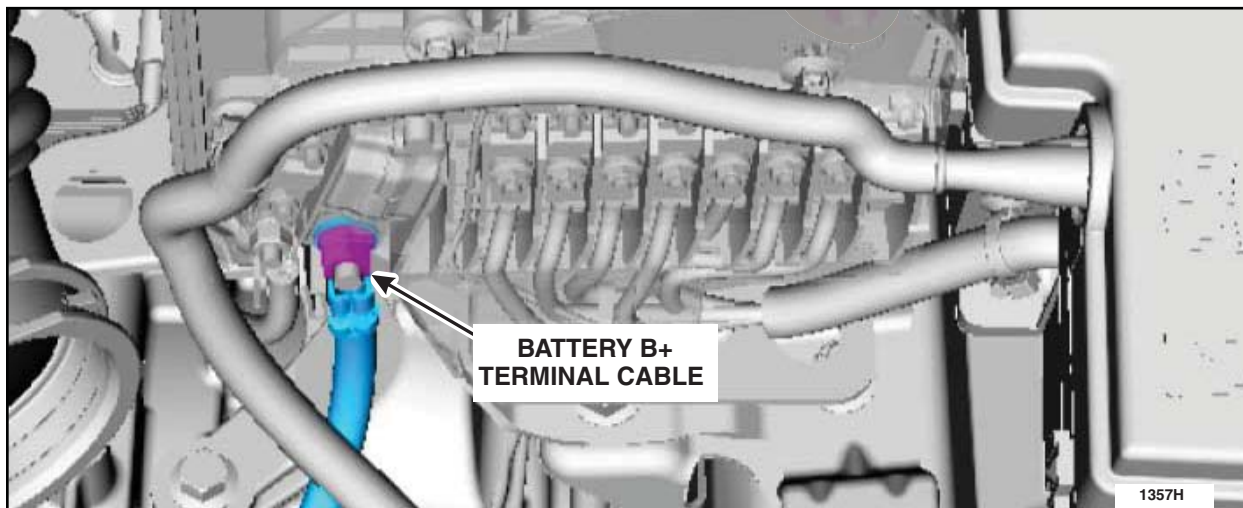

FIGURE D6

10. Connect the battery cable to ground. For additional information, refer to WSM Section 414-01.



Vehicles built on or after April 20, 2013

11. Install and connect the battery. For additional information, refer to WSM Section 414-01.



Procedure E - Coolant Stand-pipe Wire Harness Installation

OVERVIEW: The coolant stand-pipe wire harness is partially installed in this procedure. This is necessary to complete the connections at the 6-pin EPAS electrical connectors which are a part of the CAN Network. The CAN Network must be complete to allow module programming.

PARTS / SUPPLIES REQUIRED:

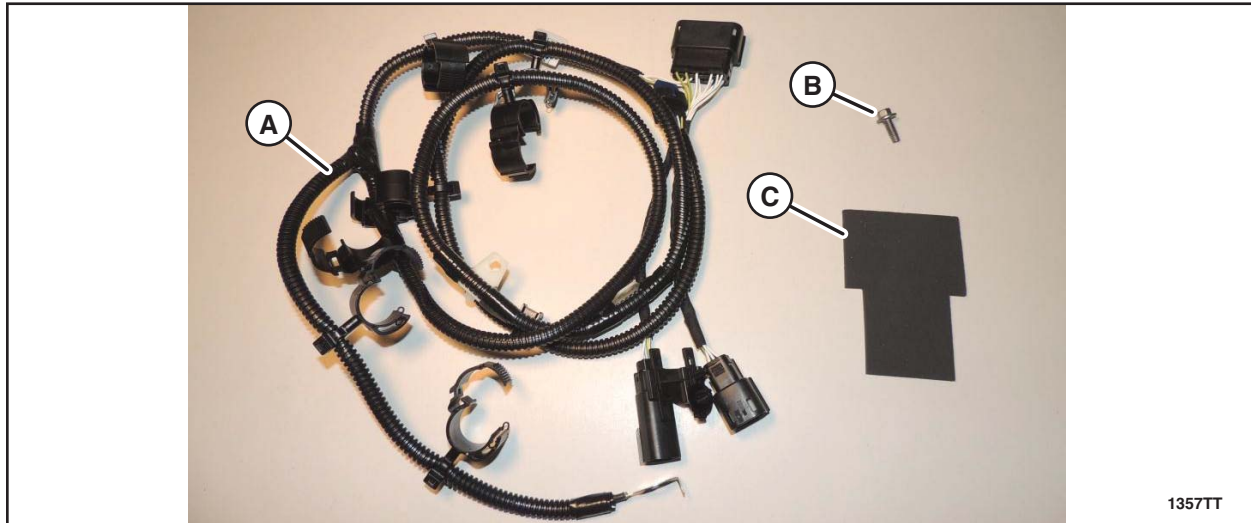

A	Coolant Stand-pipe Wire Harness
B	Wire Harness Ground Bolt
C	Protective Foam Pad

UNIQUE TOOL REQUIREMENTS: None

SERVICE TIPS: None



1. Detach the retaining clip from the battery tray mounting bracket. Disconnect the 6-pin EPAS electrical connectors. See Figure E1.

- Remove and discard the retaining clip from the 6-pin EPAS electrical connector.

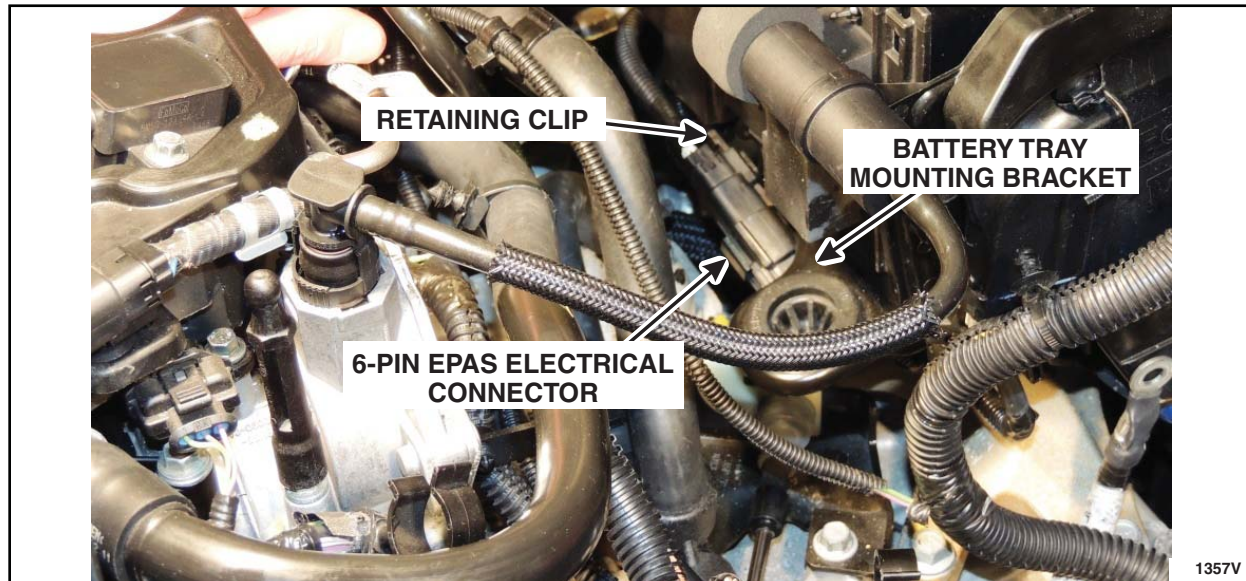

FIGURE E1

2. Connect the *new* coolant stand-pipe wire harness electrical connector to the *new* connector junction box. Apply the foam pad over the *new* connector junction box and electrical connector. See Figure E2.

NOTE: The *new* coolant stand-pipe wire harness is highlighted to show routing and connection points.

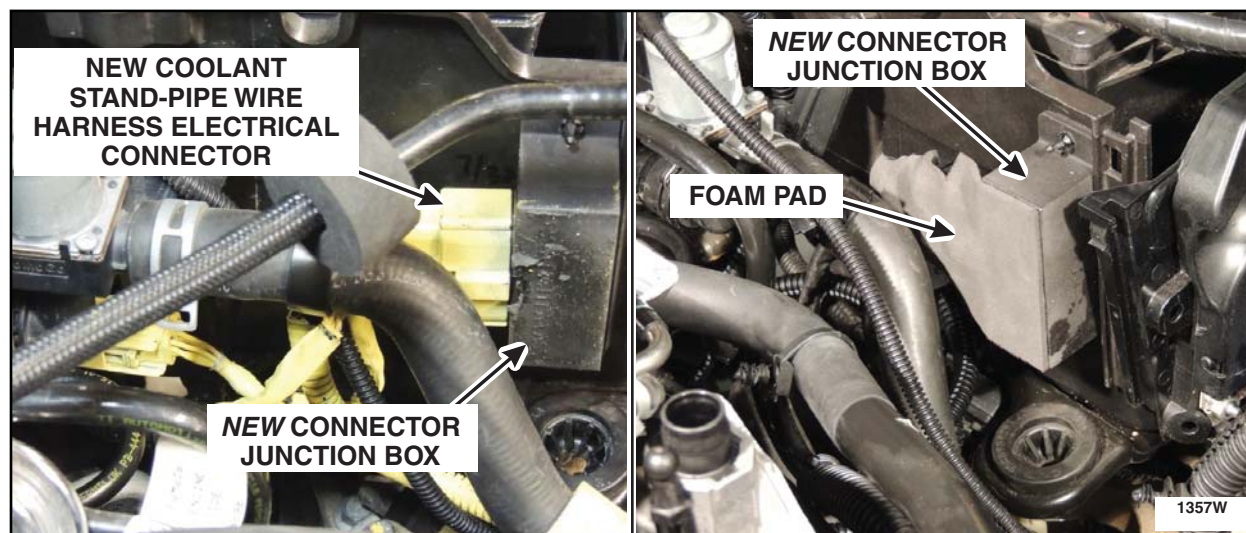

FIGURE E2



3. Connect the *new* coolant stand-pipe wire harness 6-pin electrical connectors to the 6-pin EPAS electrical connectors. See Figure E3.
4. Attach the electrical connectors (female end of coolant stand-pipe / male end of 6-pin EPAS electrical connectors) to the white retaining clip that was previously installed on the battery tray. See Figure E3.
5. Attach the electrical connectors (male end of coolant stand-pipe / female end of 6-pin EPAS electrical connectors) to the battery tray mounting bracket. See Figure E3.

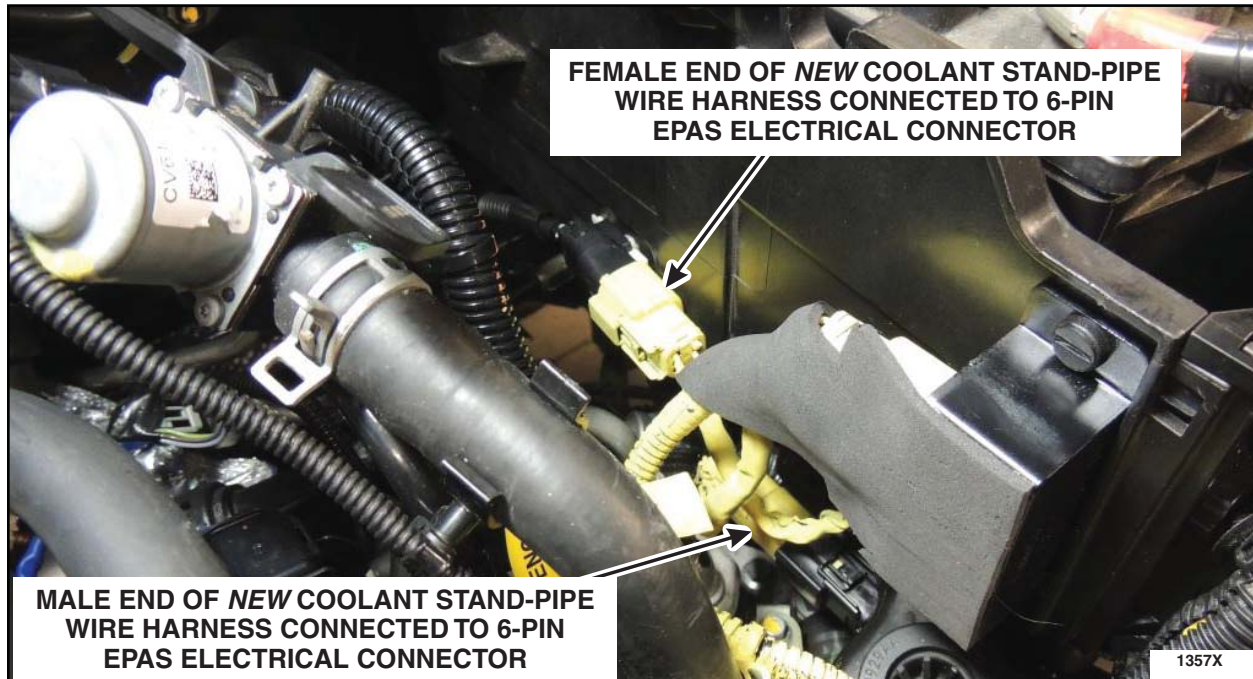

FIGURE E3



6. Install the *new* coolant stand-pipe wire harness ground eyelet to the vehicle using the *new* wire harness ground bolt. See Figure E4.

- Tighten to 12 Nm (106 lb-in).



FIGURE E4

7. Position the stand-pipe wire harness aside. It will be routed/secured and connected later.
8. Install the transmission fluid heater coolant control valve to the battery tray and install the two (2) retainers. See Figure E5.

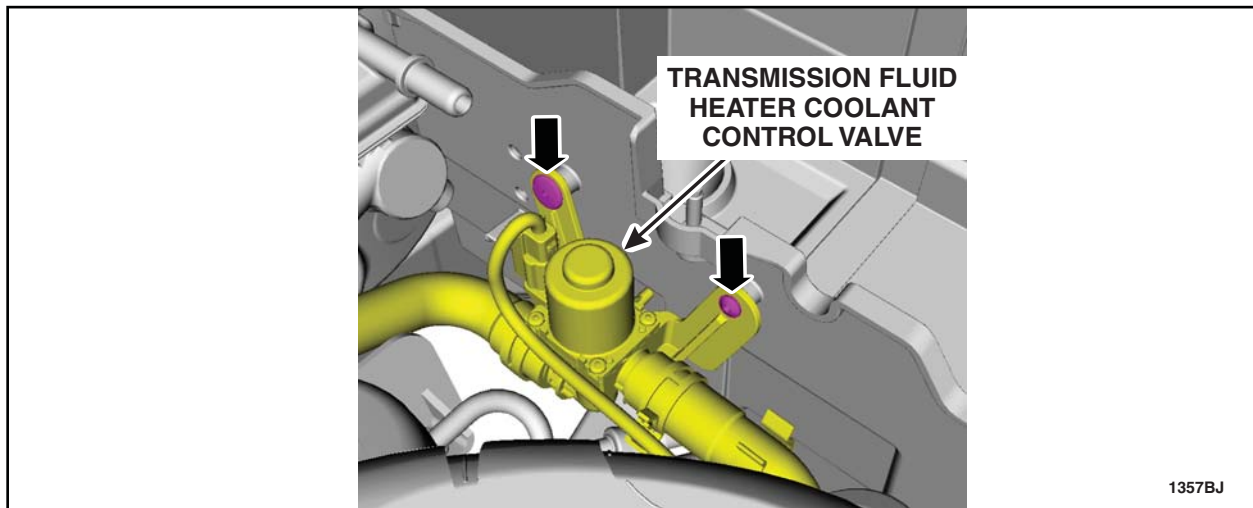

FIGURE E5



Procedure F - Instrument Panel Cluster (IPC) Reprogramming

OVERVIEW: The IPC software is being updated to coordinate cooling system improvements and instrument cluster messaging.

PARTS / SUPPLIES REQUIRED: None

UNIQUE TOOL REQUIREMENTS:

- IDS with release 89.04A or higher
- Portable battery charger (10 to 20 amps)

SERVICE TIPS: Begin IPC reprogramming and continue to perform repairs while software loads. Programming times for this IPC can be significantly reduced by using a VCM II instead of a VCM.

Important Information for Module Programming

NOTE: When programming or reprogramming a module, use the following basic checks to ensure programming completes without errors.

- Make sure the 12V battery is fully charged before carrying out the programming steps and connect IDS/scan tool to a power source.
- Inspect Vehicle Communication Module (VCM) and cables for any damage. Make sure scan tool connections are not interrupted during programming.
- A hardwired connection is strongly recommended.
- Turn off all unnecessary accessories (radio, heated/cooled seats, headlamps, interior lamps, HVAC system, etc.) and close doors.
- Disconnect/depower any aftermarket accessories (remote start, alarm, power inverter, CB radio, etc.).
- Follow all scan tool on-screen instructions carefully.
- Disable IDS/scan tool sleep mode, screensaver, hibernation modes.
- Create all sessions Key On Engine Off (KOEO). Starting the vehicle before creating a session will cause errors within the programming inhale process.

Module Reprogramming

NOTE: Reprogram appropriate vehicle modules before performing diagnostics and clear all Diagnostic Trouble Codes (DTCs) after programming. For DTCs generated after reprogramming, follow normal diagnostic service procedures.



NOTE: Current draw during reprogramming may be in excess of 10 amps. Use a battery charger set to between 10 to 20 amps. Also ensure the headlamps and accessories are turned off, in order maintain proper battery charge.

1. The IPC reprogramming can take up to 1 hour or more. Connect a portable battery charger of 10 to 20 amps to an extension cord and to the 12V battery. This will allow the vehicle to be raised and lowered as needed while completing the remaining repair procedures, and ensure uninterrupted reprogramming is achieved. Programming times can be significantly reduced by using a VCMII.

NOTE: Periodically check the status of the reprogramming progress to continue the process, as required.

2. Reprogram the IPC using IDS release 89.04A or higher.

NOTE: Calibration files may also be obtained at www.motorcraft.com.

NOTE: Follow the IDS on-screen instructions to complete the reprogramming procedure.

Recovering a module when programming has resulted in a blank module: NEVER DELETE THE ORIGINAL SESSION!

- a. Obtain the original IDS that was used when the programming error occurred during Module Reprogramming (MR) or Programmable Module Installation (PMI).
- b. Disconnect the VCM from the Data Link Connector (DLC) and the IDS.
- c. Reconnect the VCM to IDS and then connect to the DLC. Once reconnected, the VCM icon should appear in the corner of the IDS screen. If it does not, troubleshoot the IDS to VCM connection.
- d. Locate the ORIGINAL vehicle session when programming failed. This should be the last session used in most cases. If not, use the session created on the date that the programming failed.

NOTE: If the original session is not listed in the previous session list, click the "Recycle Bin" icon at the lower right of the previous session screen. This loads any deleted sessions and allows you to look through them. Double-click the session to restore it.

- e. Once the session is loaded, the failed process should resume automatically.
- f. If programming does not resume automatically, proceed to the Module Programming menu and select the previously attempted process, PMI or MR.
- g. Follow all on-screen prompts/instructions.
- h. The last screen on the IDS may list additional steps required to complete the programming process. Make sure all applicable steps listed on the screen are followed in order.



Procedure G - Turbocharger Wire Harness Taping

OVERVIEW: This procedure wraps the turbocharger wire harness with Coroplast® tape to prevent the entry/buildup of fluids and debris in the convolute which could ignite from an ignition source.

PARTS / SUPPLIES REQUIRED:

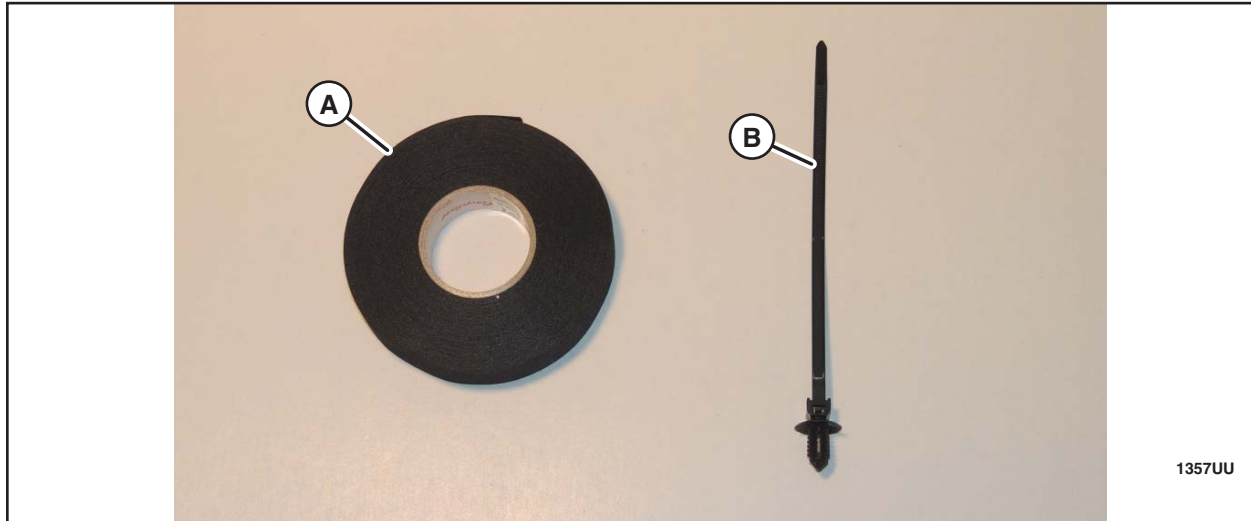

A	Coroplast® Tape
B	Wire Harness Retainer w/Zip Tie

UNIQUE TOOL REQUIREMENTS: None

SERVICE TIPS: Tips for wrapping the harness are included in the procedure.



1. Detach the wire harness retainer from the front cover, disconnect the crankshaft position sensor, turbocharger wastegate regulating valve solenoid, and turbocharger bypass valve electrical connectors. See Figure G1.

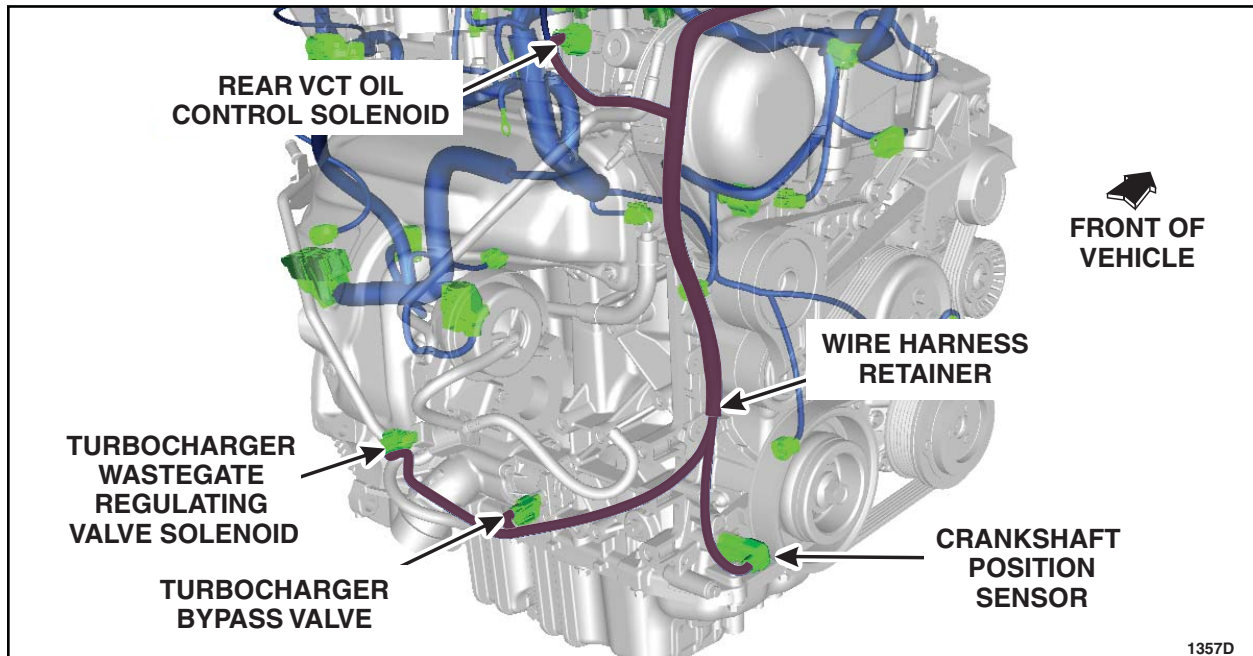

FIGURE G1

2. Route the turbocharger wire harness to the top of the engine compartment. See Figure G2.

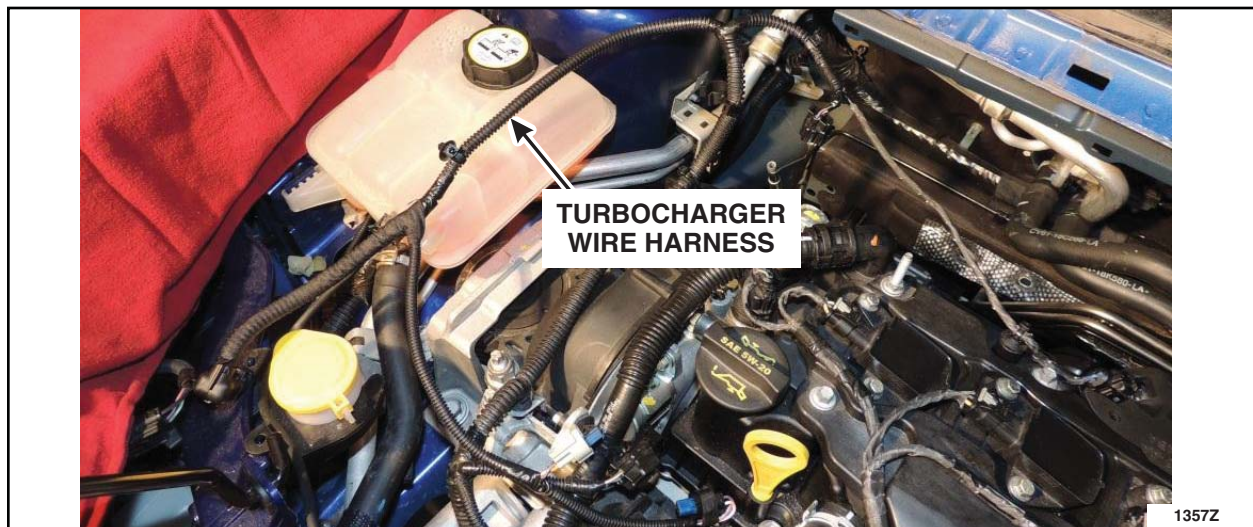

FIGURE G2



3. Disconnect the rear Variable Camshaft Timing (VCT) oil control solenoid. See Figure G1.
 - Detach the VCT harness retaining clip from the turbocharger outlet tube.
4. Replace the wire harness retainer with a *new* one supplied in the vehicle parts kit. See Figure G3.
 - Mark the wire harness retainer location before removal.
5. Wrap the turbocharger wire harness convolute with the Coroplast® tape provided in the service kit. See Figure G3.
 - Start and finish each length of tape applied with three (3) initial and three (3) finishing wraps.
 - Apply each wrap of tape with a 50% overwrap.
 - First, wrap the takeout for the crankshaft position sensor. Begin the wrap at the connector and end this portion of wrapping by going around the main harness at the takeout. See Figure G3, (A).
 - Wrap the turbocharger harness starting at the takeout to the rear VCT solenoid. Proceed down the remaining length of harness to the turbocharger wastegate regulating valve solenoid connector. See Figure G3, (B).

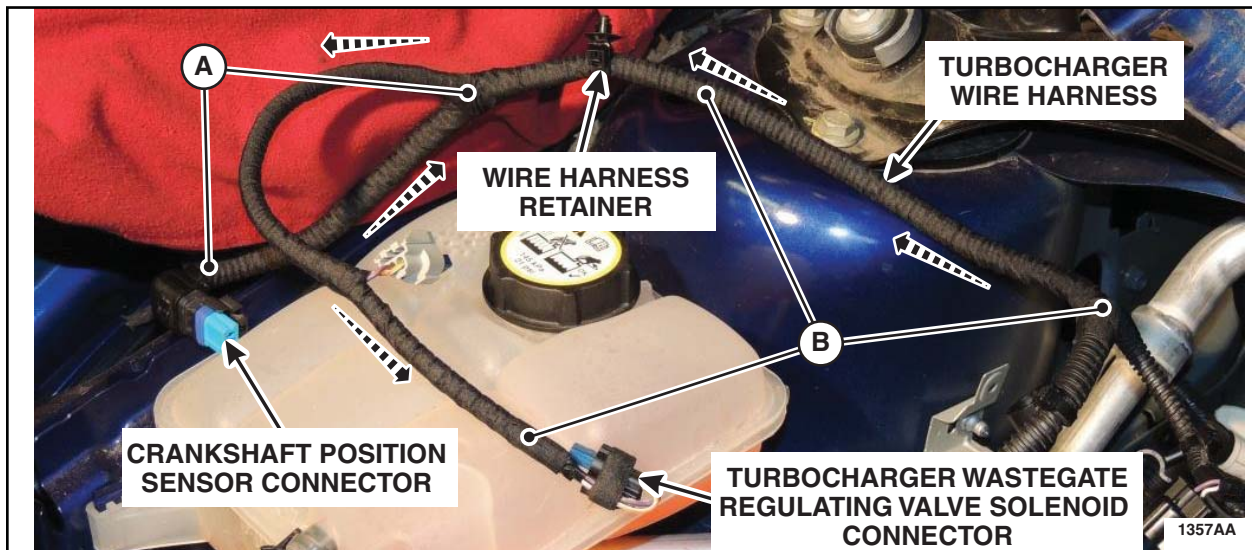

FIGURE G3

6. Connect the rear VCT oil control solenoid. See Figure G1.
 - Attach the VCT harness retaining clip to the turbocharger outlet tube.
7. Route the wire harness back down to the crankshaft position sensor, turbocharger wastegate regulating valve solenoid, and turbocharger bypass valve. See Figure G1.
8. Attach the wire harness retainer to the front cover. Connect the crankshaft position sensor, turbocharger wastegate regulating valve solenoid, and turbocharger bypass valve electrical connectors. See Figure G1.



Procedure H - Thermostat Replacement (Only Vehicles built on or before April 19, 2013)

OVERVIEW: Vehicles built on or before April 19, 2013 currently have a 90 deg. C thermostat. These are being replaced to use the cooler 82 deg. C thermostat as used in vehicles built after April 19, 2013 to improve cooling system performance.

PARTS / SUPPLIES REQUIRED:

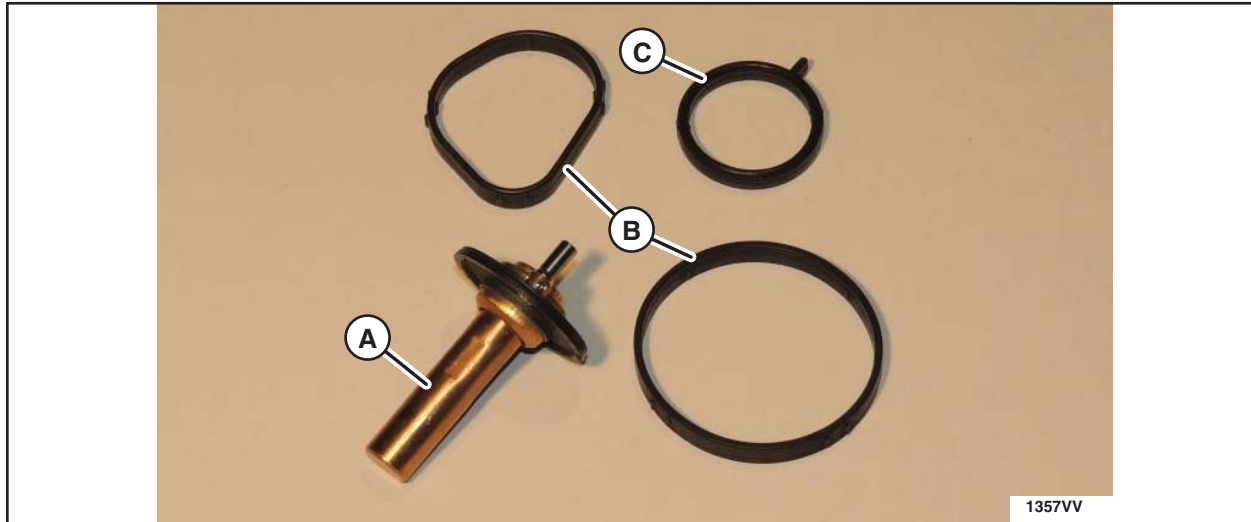

A	Thermostat
B	Thermostat housing to cylinder block O-rings (2 ea.)
C	Thermostat Housing to coolant valve O-Ring (1 ea.)

UNIQUE TOOL REQUIREMENTS: None

SERVICE TIPS: Note that the thermostat is removed and installed with the thermostat housing positioned aside and the two hoses still attached to the thermostat housing. Make sure the air bleed in the thermostat is in the "UP" position when installed to allow any air trapped in the system to pass.



NOTE: "Procedure H" only applies to vehicles built on or before 4/19/2013. For vehicles built on or after 4/20/2013, proceed to "Procedure I".

NOTE: For vehicles built on or after 4/20/2013, the thermostat, thermostat gaskets, and coolant shutoff solenoid valve o-ring provided in the vehicle parts kit are not used.

1. Remove the coolant shutoff solenoid valve. For additional information, refer to WSM Section 303-03A.

- This procedure requires removal of the generator. For additional information, refer to WSM Section 414-02.
- Do not disconnect the battery as referenced within generator removal and installation. The battery B+ terminal cable was disconnected during "Procedure D", to remove battery voltage from the generator cable during thermostat replacement.

2. Remove the four bolts and position the thermostat housing aside to access to the thermostat. See Figure H1.

- Discard the thermostat housing gaskets.

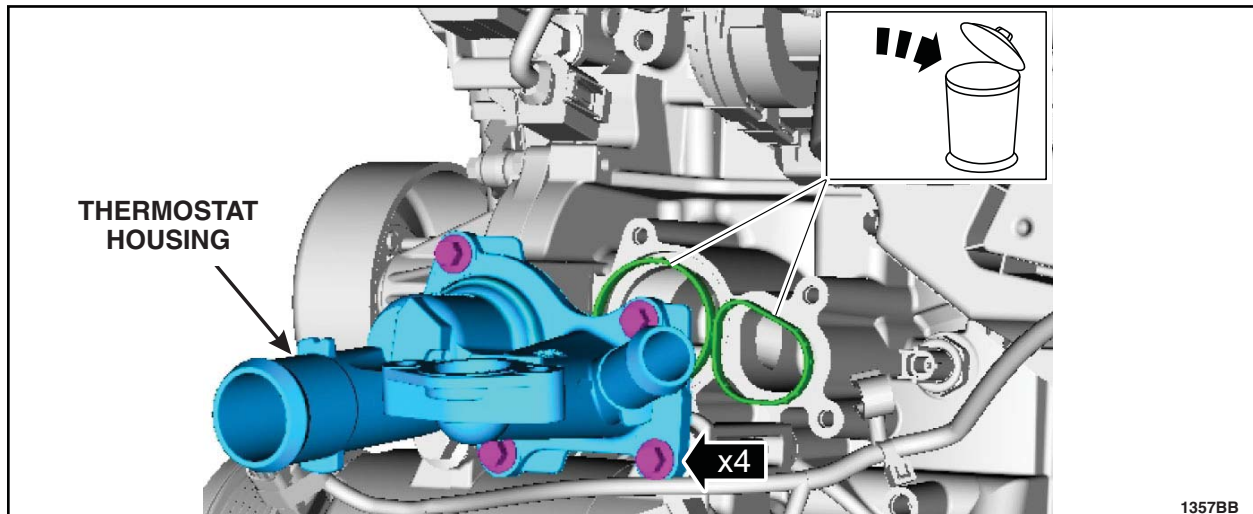

FIGURE H1



3. Use a 13 mm (1/2 in) deep well socket to press downward on the thermostat retaining clip and rotate to remove it from the thermostat housing. Remove the thermostat spring. See Figure H2.

- Note the position of the thermostat retaining clip and thermostat prior to removing. See Figures H2 and H4.

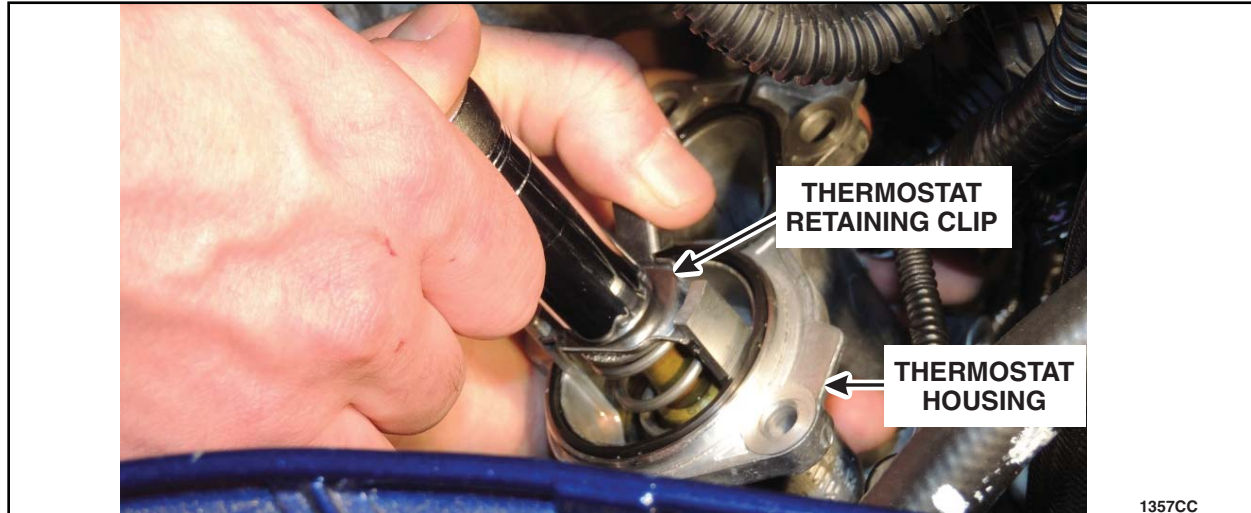

FIGURE H2

4. Remove and discard the thermostat. See Figure H3.

5. Position the *new* thermostat into the housing with the air bleed hole positioned upward. Use a 13 mm (1/2 in) deep well socket to install the thermostat spring and clip. The retaining clip must be in the same orientation that it was in prior to removal. See Figures H3 and H4.

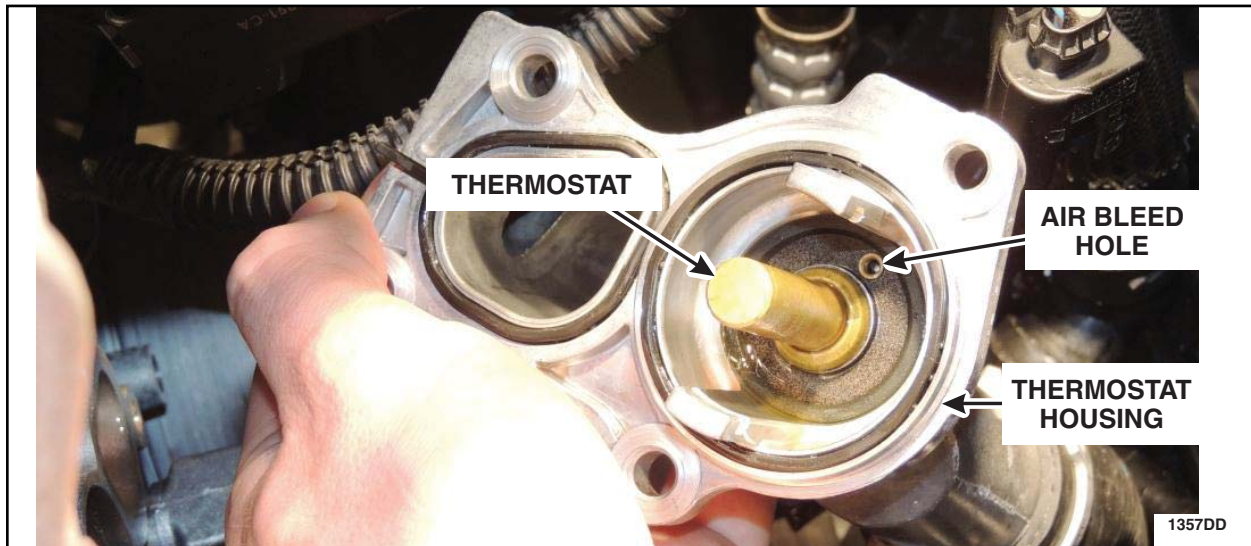

FIGURE H3



NOTICE: Do not use pliers or other tools to install the thermostat.

NOTE: The thermostat retaining clip must be installed in the position as shown. See Figure H4.

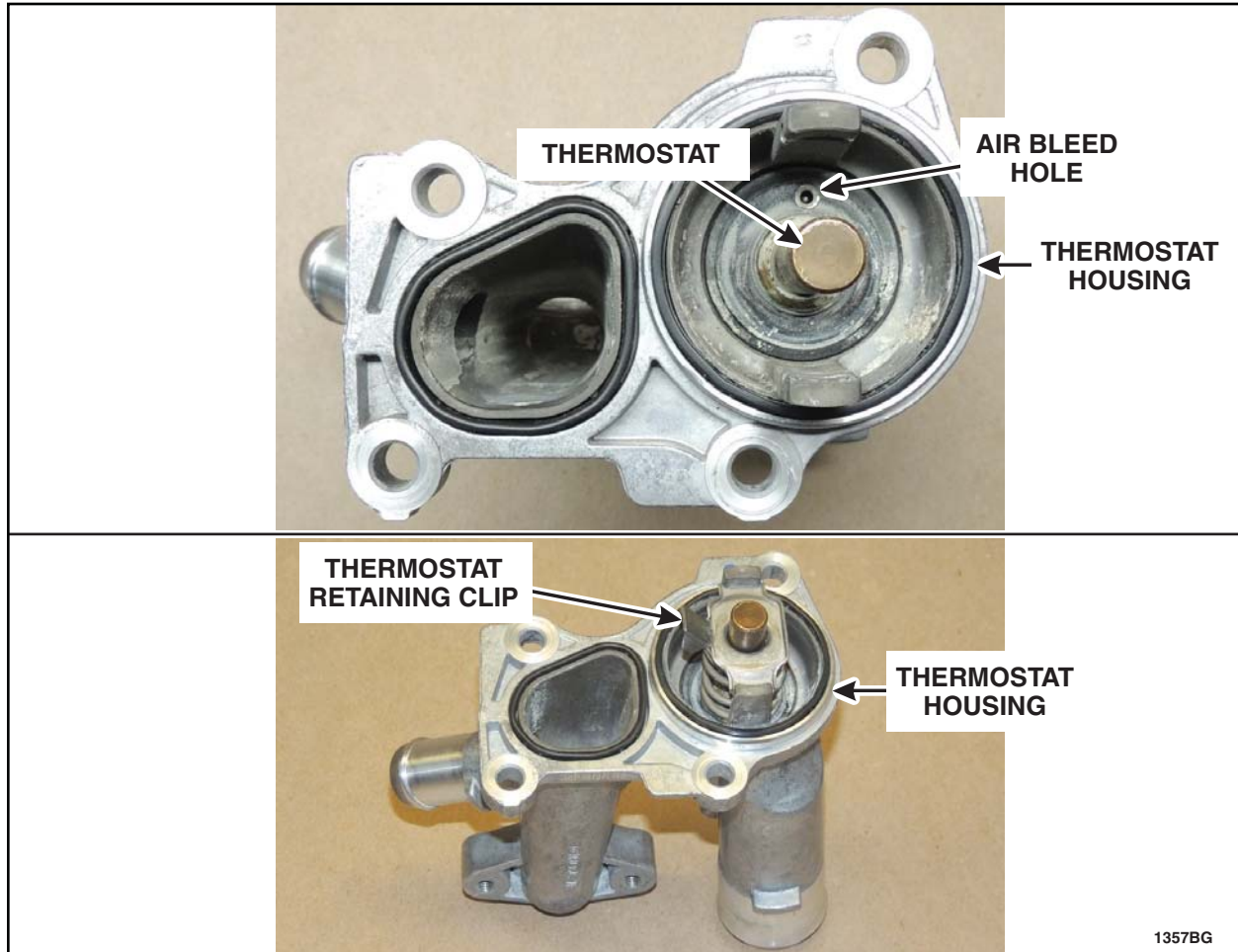

FIGURE H4

6. Install *new* thermostat housing gaskets and position the thermostat housing onto the engine. Install the four bolts. See Figure H1.

- Tighten the bolts to 10 Nm (89 lb-in).

7. Install the coolant shutoff solenoid valve and generator. For additional information, refer to WSM Section 303-03A.

- Do not connect the cooling hose quick connect T-fitting to the coolant shutoff solenoid valve at this time.



Procedure I - Coolant Degas Bottle, Degas Bottle Cap, and Coolant Hose Replacement

OVERVIEW: In this procedure, the coolant degas bottle and cap are replaced with an updated assembly. The coolant hose that runs between the degas bottle and thermostat quick connect T-fitting is replaced with an updated hose that allows for connection to the turbocharger coolant return line and the new coolant stand-pipe. In addition, the o-ring in the quick connect T-fitting is updated for better sealing characteristics.

PARTS / SUPPLIES REQUIRED:

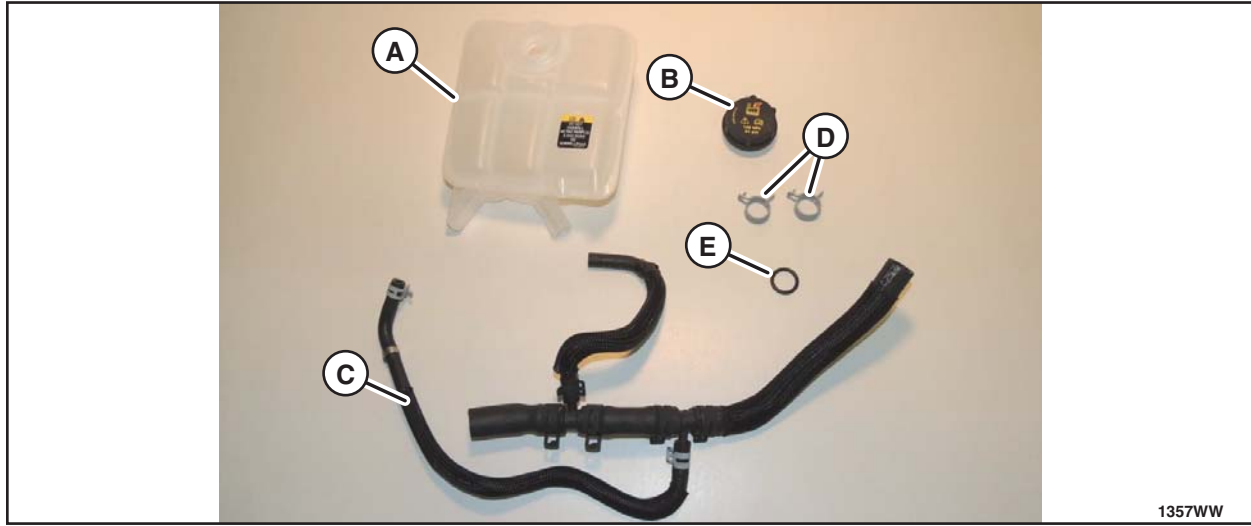

1357WW

A	Coolant Degas Bottle
B	Coolant Degas Bottle Cap
C	Coolant Degas Bottle to Thermostat Housing Hose
D	Large Hose Clamps (2 ea.)
E	Quick Connect T-fitting O-Ring

UNIQUE TOOL REQUIREMENTS: None

SERVICE TIPS: See Figure below for coolant degas bottle to thermostat housing hose connection points.

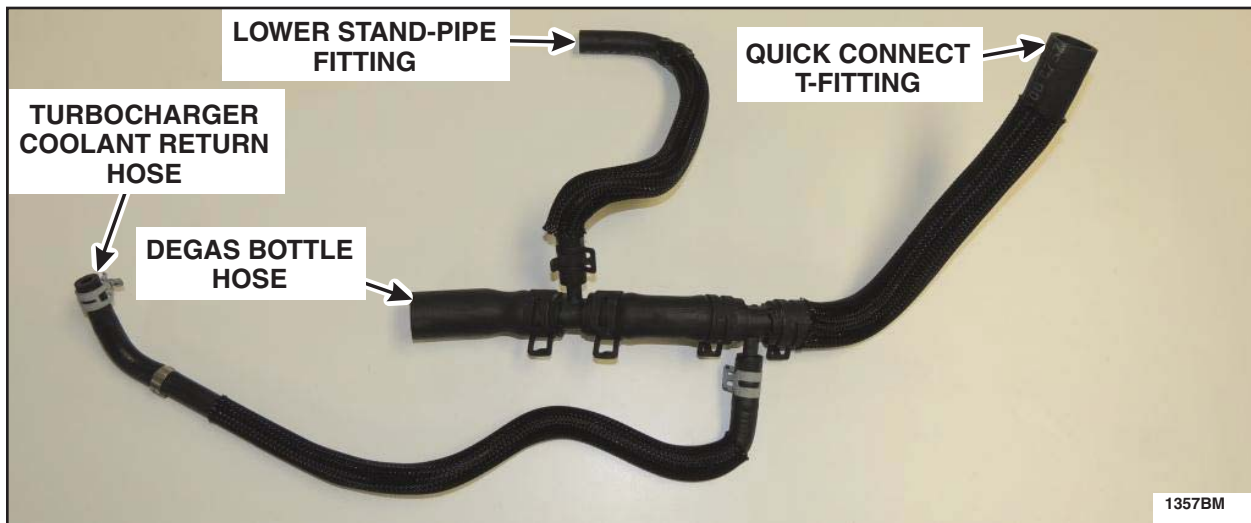

1357BM



1. Remove and discard the coolant degas bottle and degas bottle cap. For additional information, refer to WSM Section 303-03A.
2. If not done previously, release the clip and disconnect the quick connect T-fitting from the coolant shutoff solenoid valve. See Figure I1.

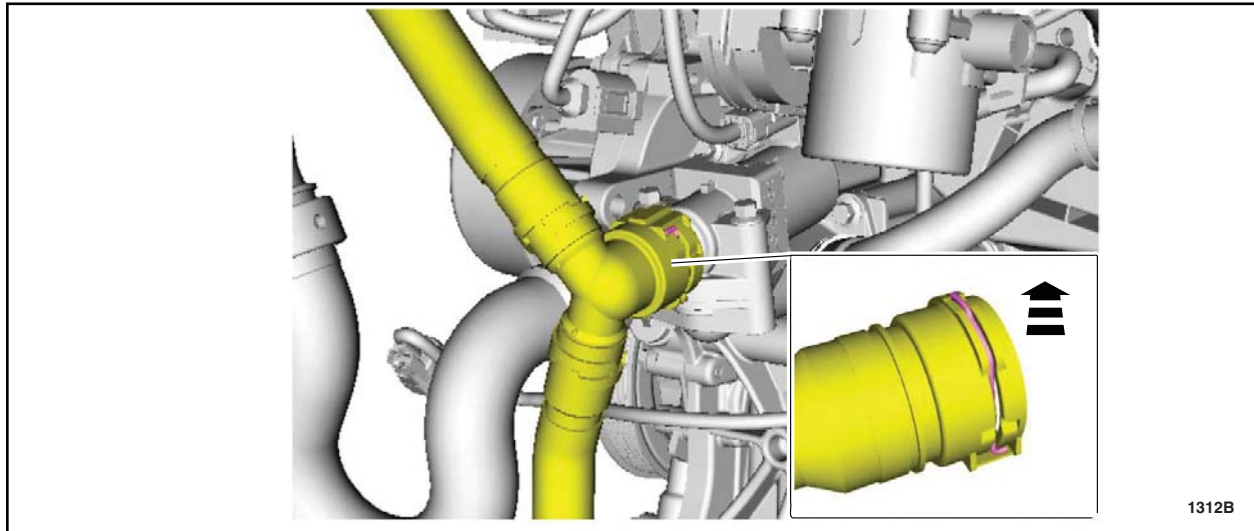

FIGURE I1

3. Position the degas bottle hose downward out the bottom of the engine compartment. See Figure I2.
 4. Use a pair of needle nose VISE-GRIP® pliers to compress the degas bottle hose clamp and slide the clamp downward off of the quick connect T-fitting. See Figure I2.
- Space the needle nose VISE-GRIP® plier teeth 6.35 mm (0.25 in) apart when closed so that they will fully compress the hose clamp when locked, to allow the clamp to be slid down the hose for hose removal.

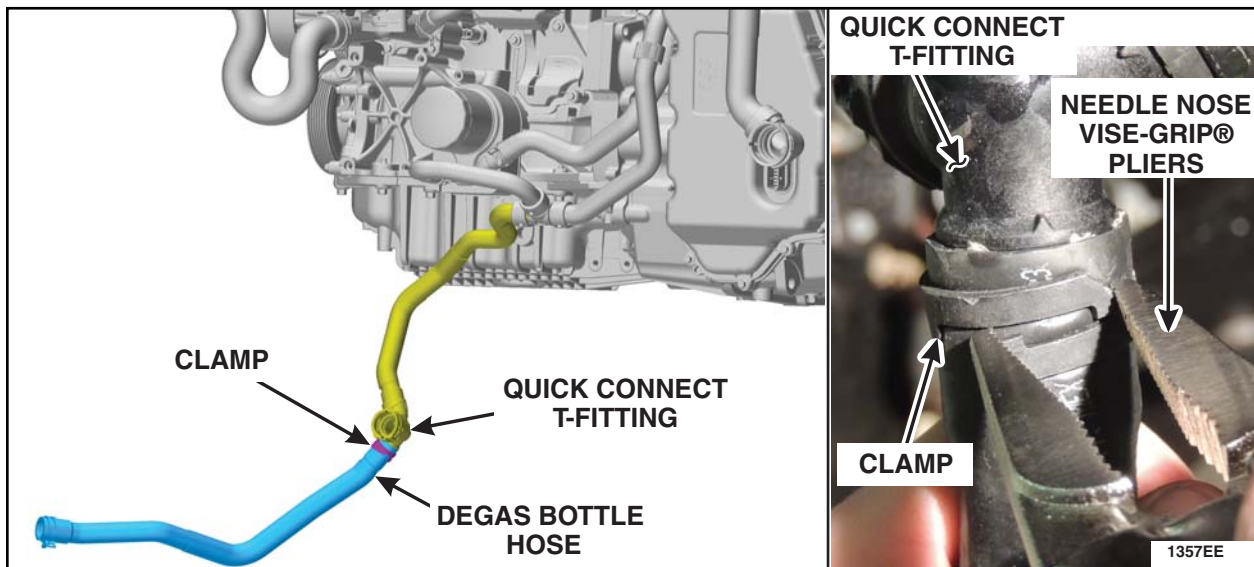

FIGURE I2



5. Remove and discard the degas bottle hose and clamp. See Figure I2.

NOTE: Lubricating the new coolant hoses with coolant will aid in easier installation.

6. Position a *new* clamp onto the longer section of the *new* degas bottle hose and install the hose onto the quick connect T-fitting. Ensure the "I" mark on the *new* degas bottle hose is aligned with the alignment mark on the quick connect T-fitting. Also align the clamp center with the "I" mark. See Figure I3.

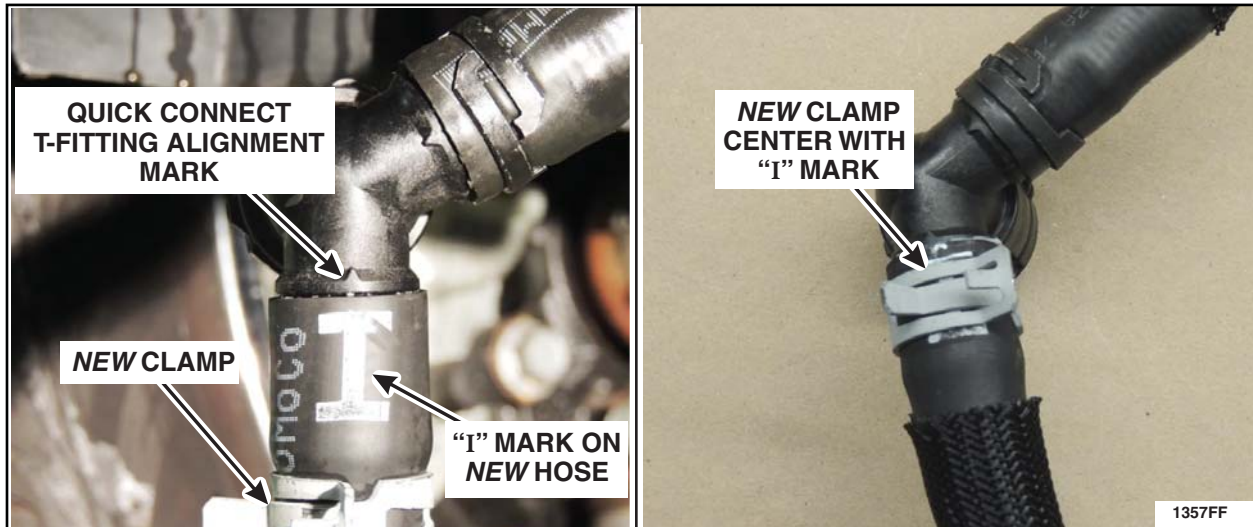

FIGURE I3

7. Remove and discard the o-ring inside the quick connect T-fitting. See Figure I4.

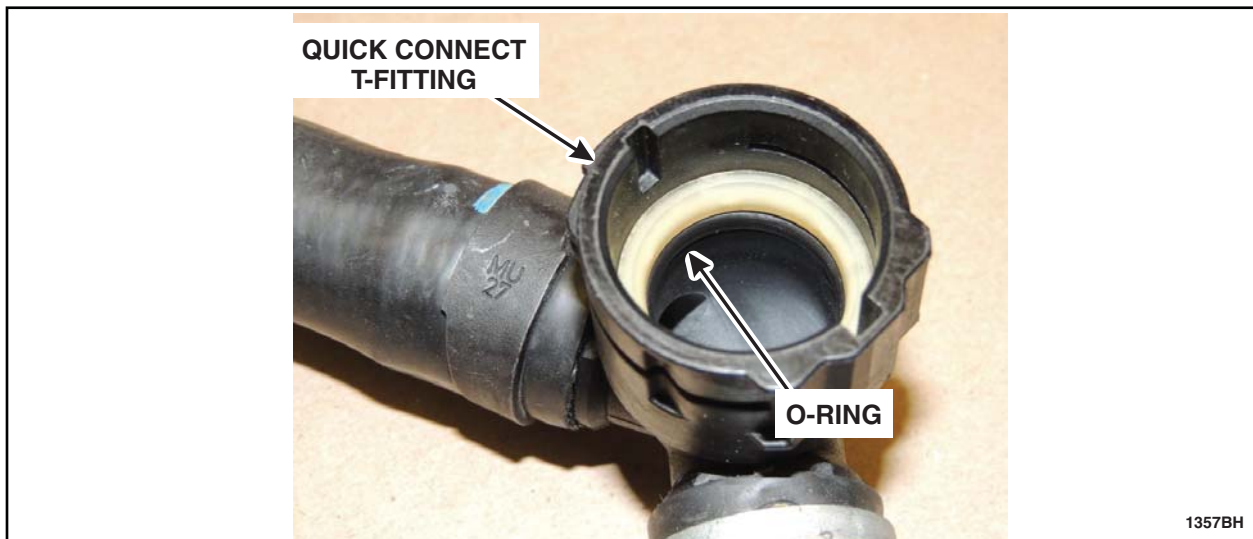

FIGURE I4

8. Ensure the inside of the quick connect T-fitting is free from dirt and debris.

9. Lubricate the new o-ring with coolant and install it into the quick connect T-fitting. See Figure I4.



10. Route the degas bottle hose upward, back to the degas bottle and to the turbocharger outlet tube.
11. Connect the quick connect T-fitting to the coolant shutoff solenoid valve. See Figure I5.

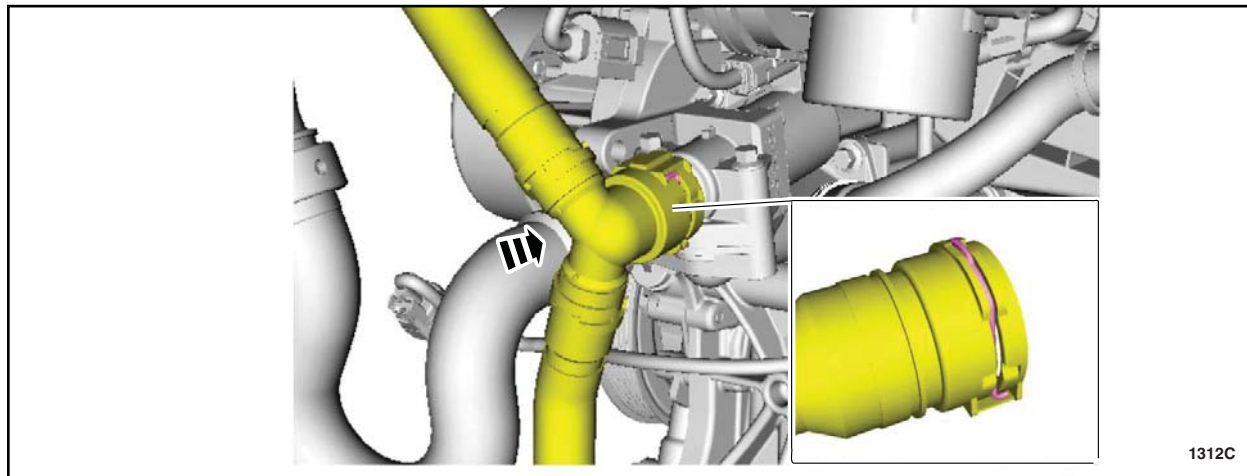

FIGURE I5

12. Position a *new* clamp onto the degas bottle hose. Install the *new* coolant degas bottle and degas bottle cap provided in the kit. For additional information, refer to WSM Section 303-03A.

- Do not fill the cooling system at this time.

13. Connect the *new* turbocharger coolant return hose to the turbocharger coolant outlet tube and release the clamp. Attach the wire harness retainer to the *new* turbocharger coolant return hose. See Figure I6.

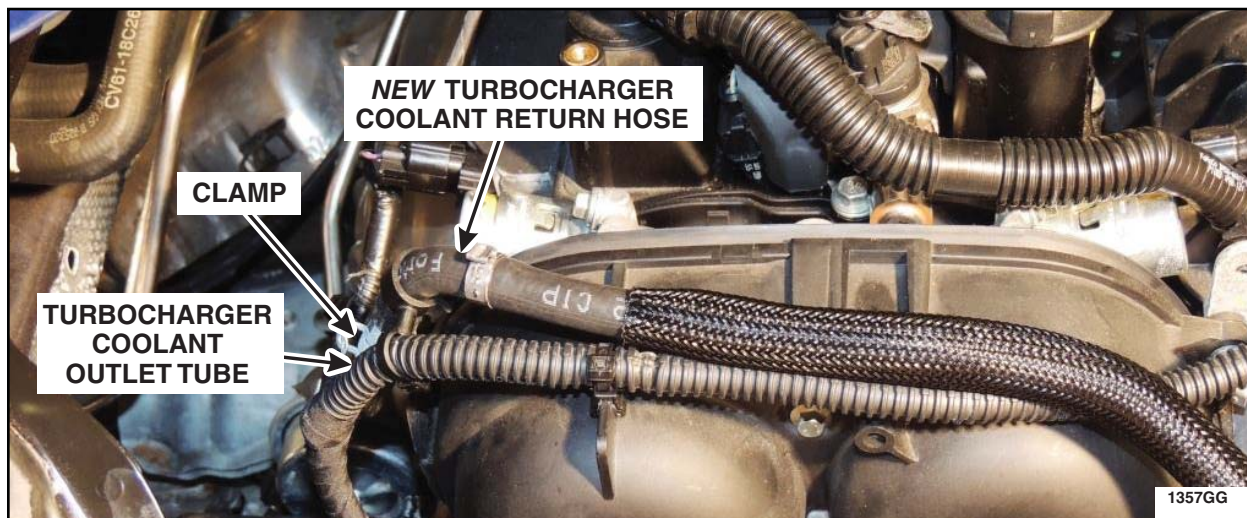

FIGURE I6



Procedure J - Coolant Stand-pipe Installation

OVERVIEW: The coolant stand-pipe provides coolant level information to the PCM and IPC via the CAN network to prevent overheating issues due to low coolant level and also inform the operator when the coolant level is low. The coolant stand-pipe is installed to the RH side of the radiator support. On installation, the wiring harness is routed across the radiator support and connected, and the related coolant hoses are attached.

PARTS / SUPPLIES REQUIRED:

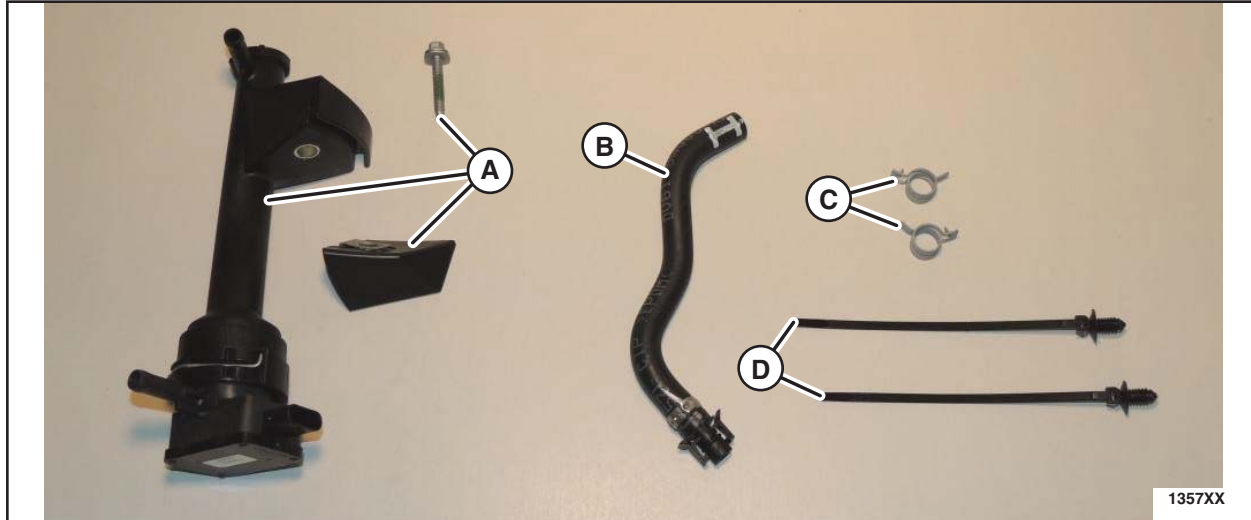

A	Coolant Stand-pipe and Attaching Hardware
B	Coolant Stand-pipe to Degas Bottle Hose
C	Small Hose Clamps (2 ea.)
D	Wire Harness Retainers w/Zip Tie (2 ea. of 3 provided, if needed)
E	PM-13-A Rust Preventative (Supplied in Dealer Kit - Not Shown)

UNIQUE TOOL REQUIREMENTS: 8 mm (5/16" / 0.31 in) drill bit.

SERVICE TIPS: The wire harness retainers with zip ties are provided in the event the two retainers securing the existing wire harness across the radiator support are damaged during removal and installation of the coolant stand pipe wire harness.



1. Disconnect the parking lamp electrical connector at the RH headlamp. See Figure J1.
2. Remove the rubber plug from the RH headlamp. See Figure J1.

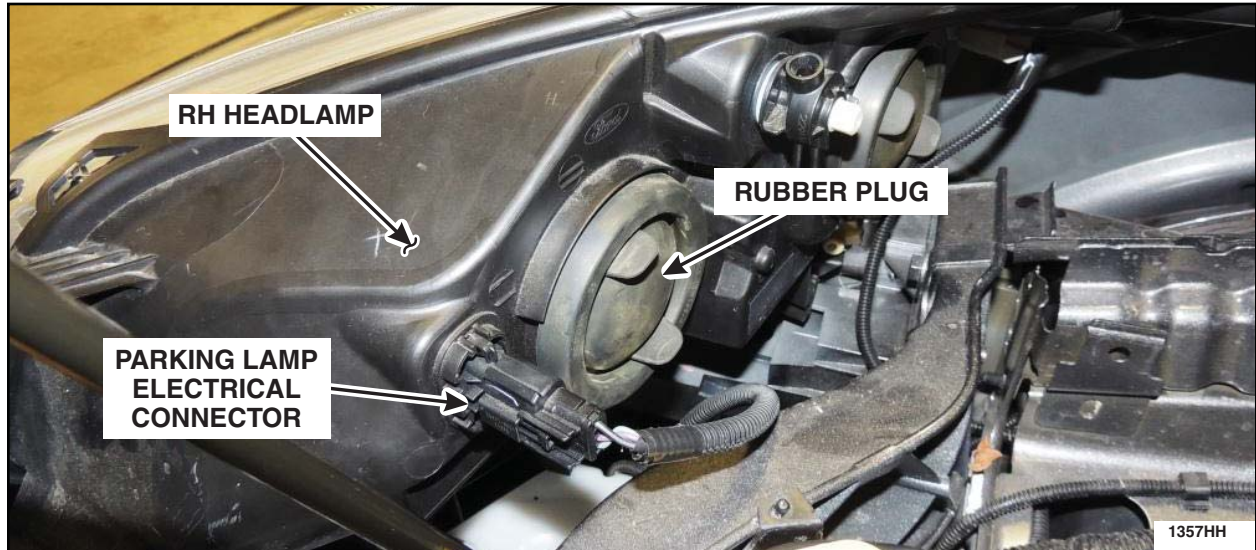

FIGURE J1

3. Position the *new* coolant stand-pipe assembly in place on the radiator bolster. Mark the center of the *new* coolant stand-pipe mounting hole location on the radiator bolster, and remove the *new* coolant stand-pipe. See Figure J2.

- The stand-pipe bracket groove fits over the radiator bolster raised rib.

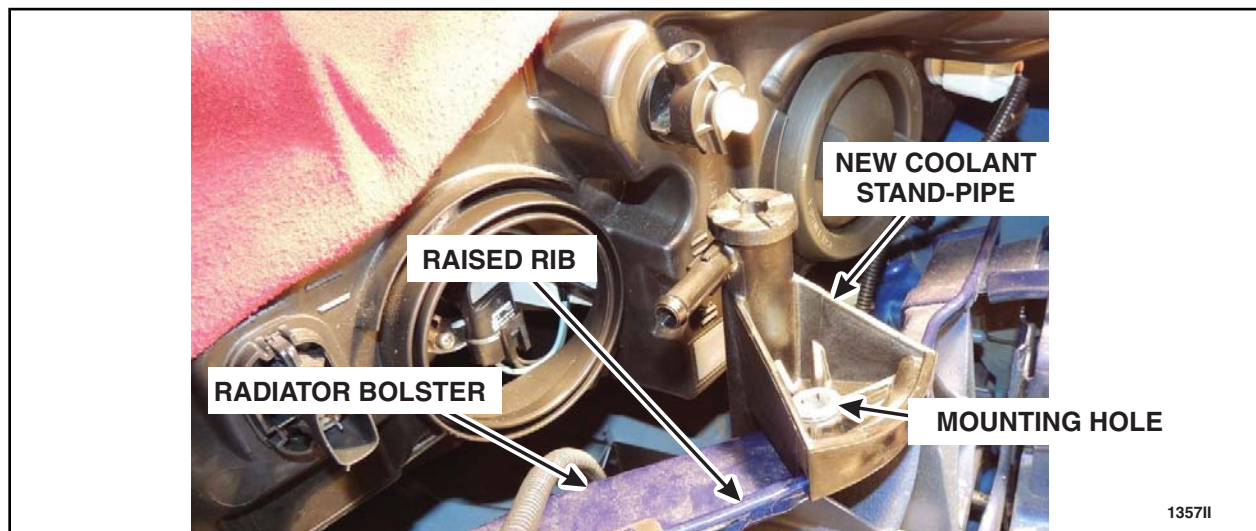

FIGURE J2

4. Gently center-punch the marked location on the radiator bolster. Drill a 8 mm (5/16" / 0.31 in) hole through the radiator bolster at the previously marked location.

- Deburr the top and underside of the drilled hole in the radiator bolster.
- Apply PM-13-A corrosion preventative coating to the drilled location.



5. Route and secure the *new* coolant stand-pipe wire harness along the front of the engine and radiator bolster. See Figure J3.
 - a. Route the coolant stand-pipe wire harness **under the fuel vapor tube**.
 - b. For vehicles equipped with an anti-theft hood switch, release the two (2) anti-theft hood switch wire harness retainers at the right front radiator bolster. If damaged replace the two wire harness retainers with the two (2) wire harness retainers supplied in the vehicle parts kit. Secure the coolant stand-pipe harness retainers in the radiator bolster mounting positions and then re-secure the anti-theft hood switch harness to the mounting positions in the *new* harness.
 - c. For vehicles **not** equipped with an anti-theft hood switch, secure the coolant stand-pipe harness retainers in the unused radiator bolster mounting positions.

NOTE: The coolant stand-pipe electrical connector will be connected after the coolant stand-pipe is installed.

NOTE: The *new* coolant stand-pipe wire harness is highlighted to show routing and connection points.

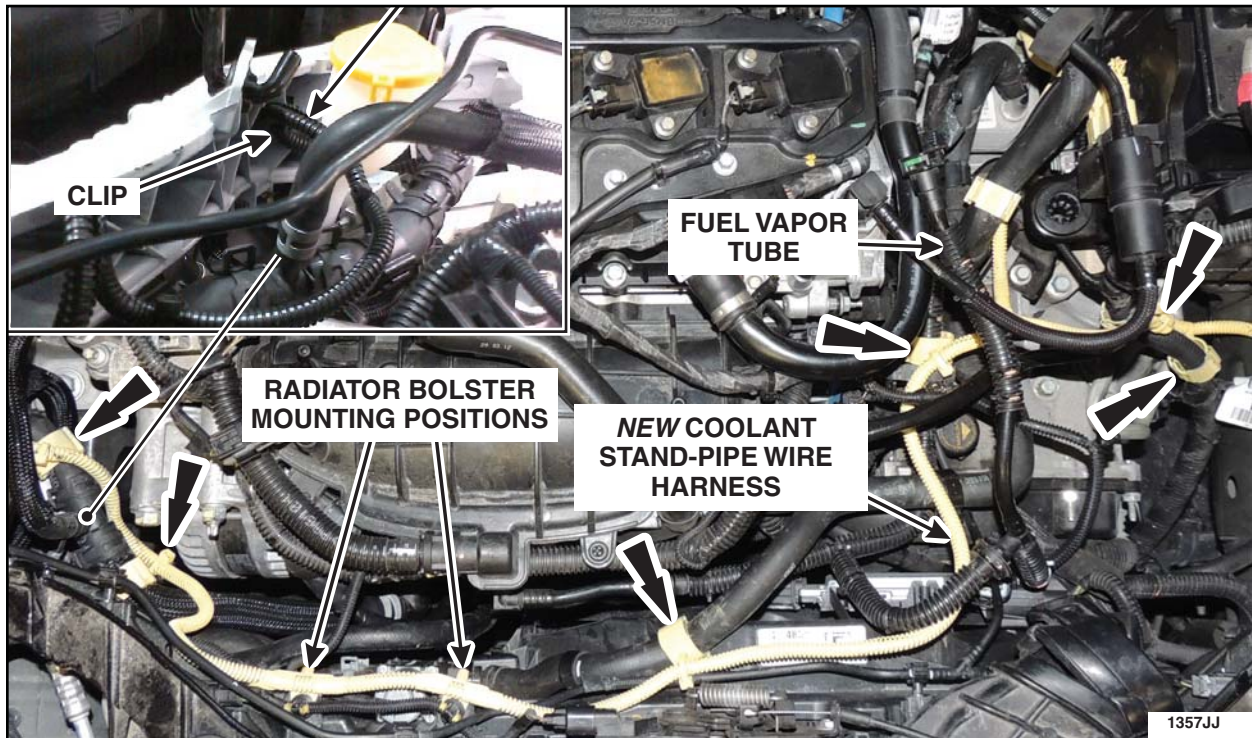

FIGURE J3



6. Connect the *new* coolant stand-pipe wire harness electrical connector to the *new* coolant stand-pipe. See Figure J4.
7. Install the *new* clamp onto the *new* lower hose. Align and connect the *new* lower hose from the previously installed *new* coolant hose assembly to the lower port on the *new* coolant stand-pipe. See Figures J4 and J5.
 - Route the lower hose between the A/C lines and to the *new* coolant stand-pipe. See Figure J5.
 - Ensure the "I" mark on the *new* lower hose is in the 12 o'clock position. See Figure J4.
 - The *new* clamp, when installed, should also be aligned with the "I" mark, in the 12 o'clock position. See Figure J4.

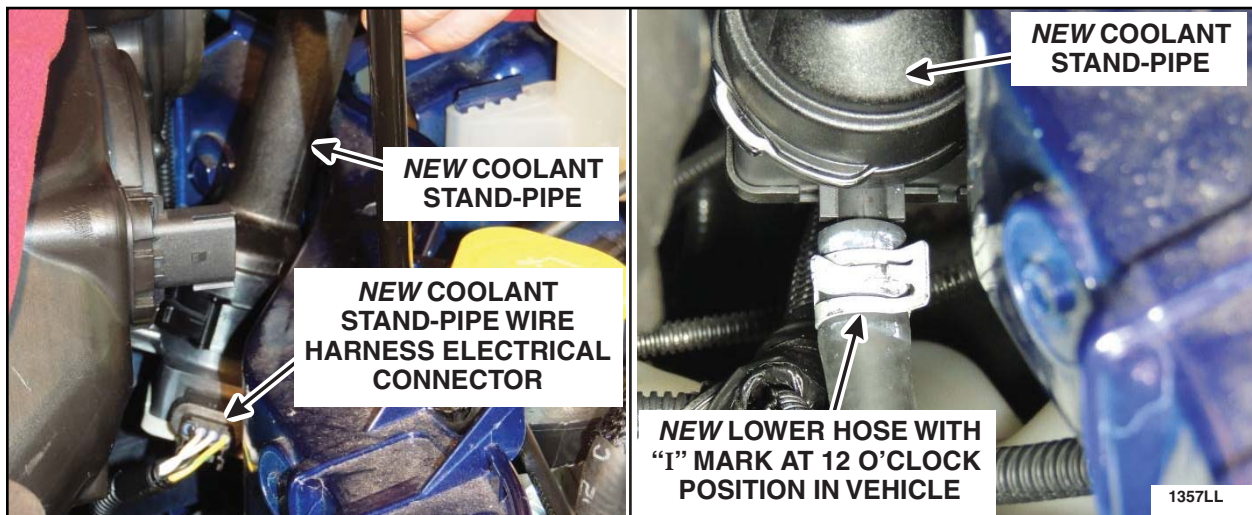

FIGURE J4

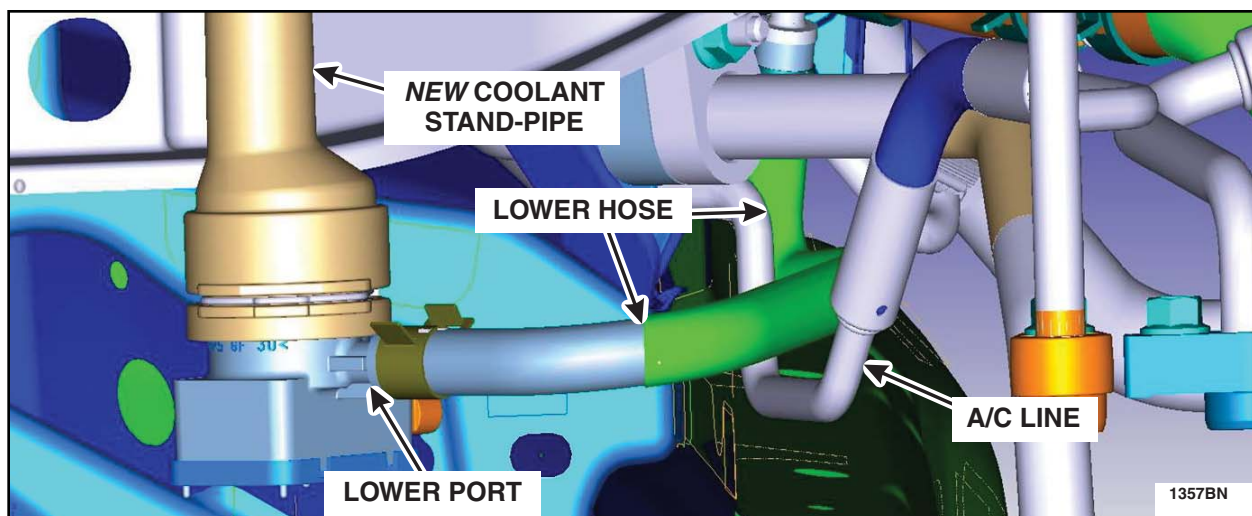

FIGURE J5



8. Place the *new* coolant stand-pipe attaching block in position below the radiator bolster. Place the *new* coolant stand-pipe in position and install the *new* bolt. See Figure J6.

- Tighten the bolt to 8 Nm (71 lb-in).

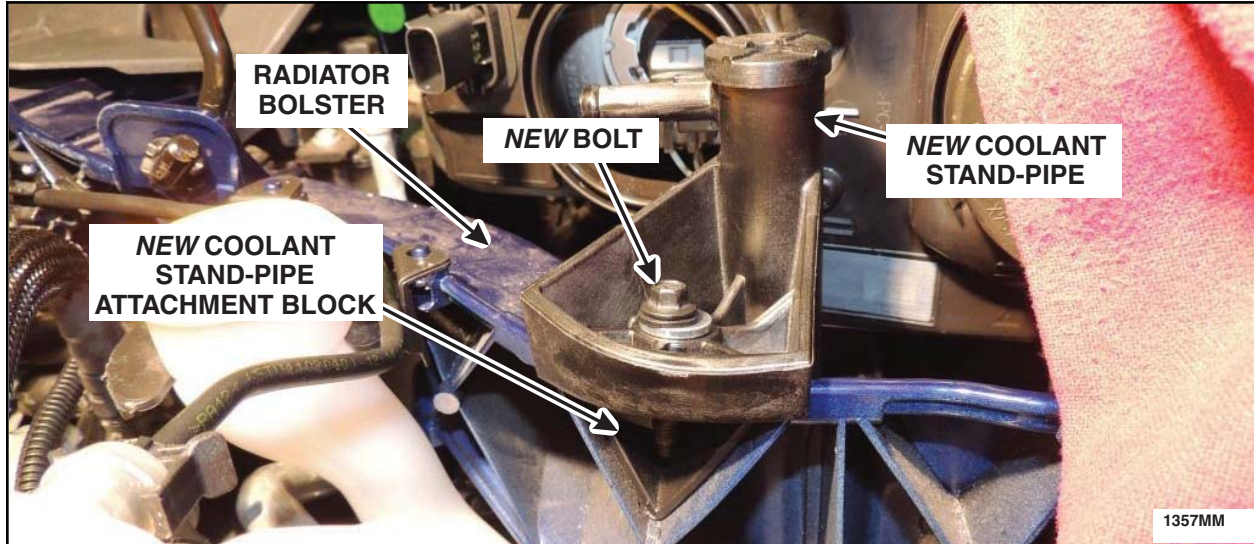

FIGURE J6

9. Install the *new* clamp. Align and connect the *new* upper hose to the top port on the *new* coolant stand-pipe and to the RH port on the degas bottle. See Figures J7 and J8.

- Ensure the "I" mark on the *new* upper hose is in the 12 o'clock position, aligned with top rib of stand-pipe top port. See Figure J7.
- The *new* clamp when installed should also be aligned with the "I" mark in the 12 o'clock position. See Figure J7.



FIGURE J7



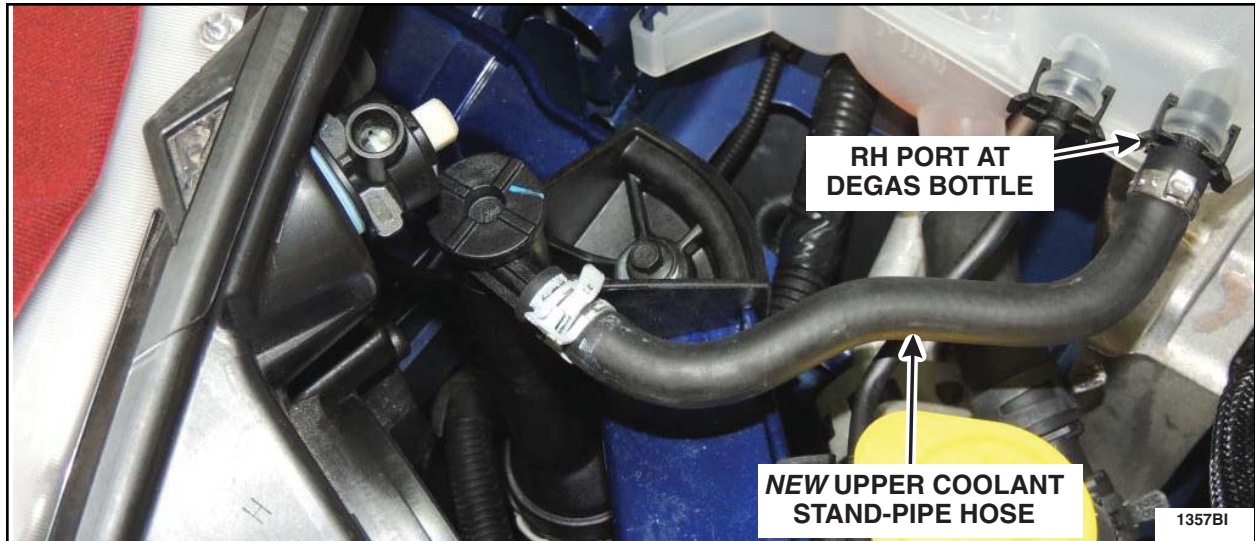

FIGURE J8

10. Install the rubber plug onto the RH headlamp. See Figure J1.
11. Connect the parking lamp electrical connector at the RH headlamp. See Figure J1.

NOTE: Check the status of the IPC reprogramming progress.



Procedure K - Front Under-body Air Deflector Modification

OVERVIEW: Holes are punched in the forward Under Body Air Deflector so that any fluid leaks that could occur would not be trapped on the top of the panel which could pose a risk for fire.

PARTS / SUPPLIES REQUIRED:

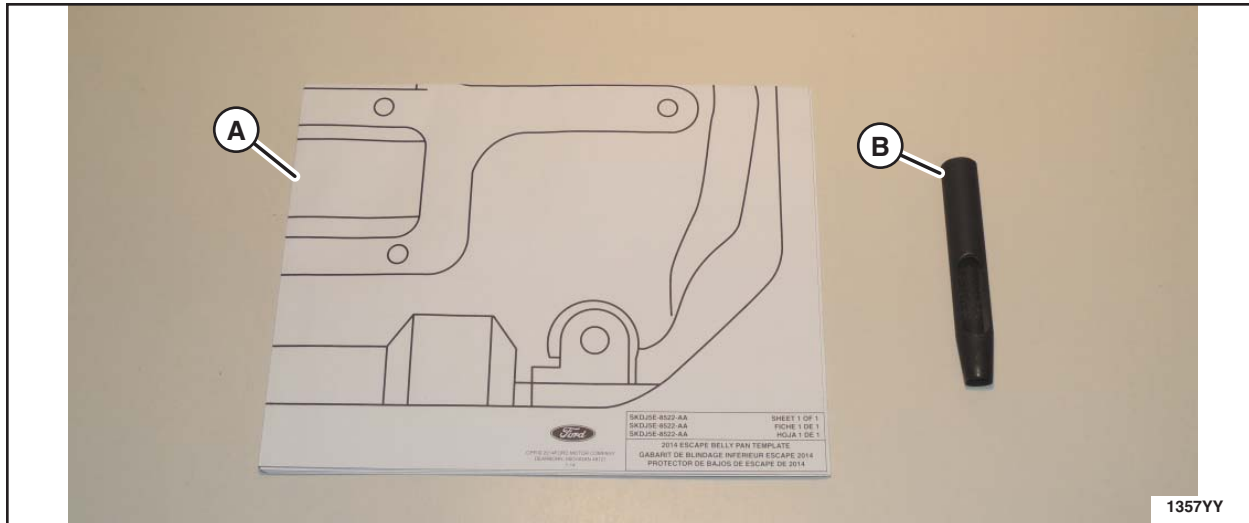

A	Under-body Air Deflector hole punch template
B	12.5 mm (0.5 in) Material Hole Punch (100-D702) (Included in Dealer Kit)

UNIQUE TOOL REQUIREMENTS: 12.5 mm (0.5 in) Material Hole Punch, Tool Number 100-D702.

SERVICE TIPS: A piece of scrap lumber is required for Step 3.



1. Place hole punch template included in the kit over the engine side of the front under-body air deflector. Align the two mounting holes identified on the template with the two corresponding holes on the air deflector. See Figure K1.

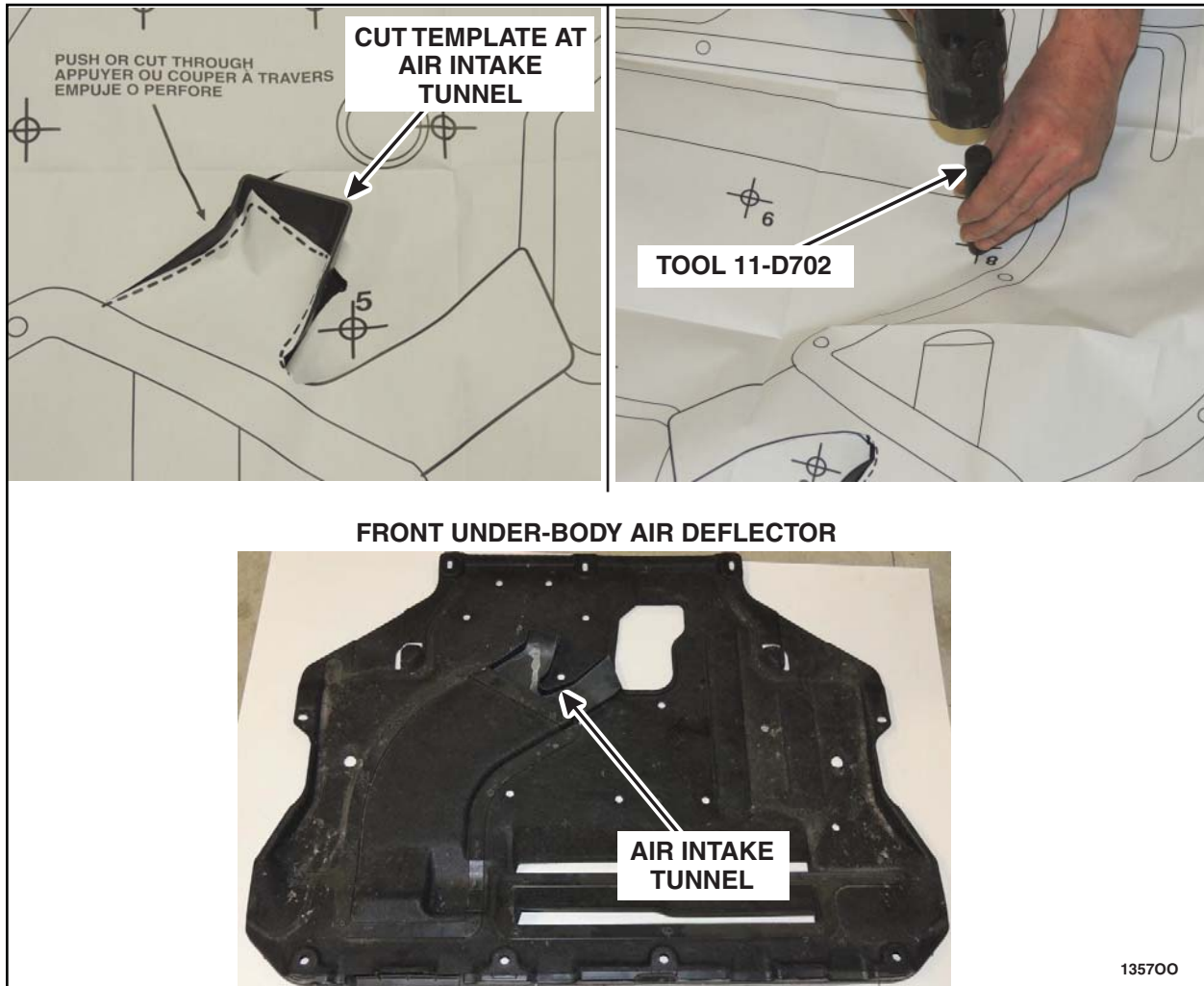

FIGURE K1

2. Cut or push through the area indicated on the template that aligns with the air intake tunnel, near punch location number 5, to allow the template to lay flat on the air deflector. See Figure K1.
3. Position a piece of scrap lumber below the area to be punched. Using a hammer and Hollow Material Punch (Tool 100-D702) provided in the dealer kit, punch out the 11 hole locations identified on the template. See Figure K1.
4. Set the front under-body air deflector aside for installation later.



Procedure L - Lower Active Grille Shutter (AGS) Modification

OVERVIEW: The second and third row shutters in the lower Active Grille Shutter (AGS) assembly will be removed to provide additional airflow in the engine compartment.

PARTS / SUPPLIES REQUIRED: None

UNIQUE TOOL REQUIREMENTS: Coarse 18 tooth-per-inch hacksaw blade and hacksaw blade holder (commercially available).

SERVICE TIPS: Follow the procedure to remove the 2nd and 3rd row grille shutters from the bottom of the lower AGS assembly. Verify all remaining AGS Shutters are connected and move freely by moving the mechanism physically after modification.

NOTICE: Place a suitable cover on the lower front bumper grille opening to protect the paint from damage during the cutting operation.

1. Locate the shutters in the 2nd and 3rd positions from the bottom of the lower AGS assembly through the lower front bumper grille opening. See Figure L1.

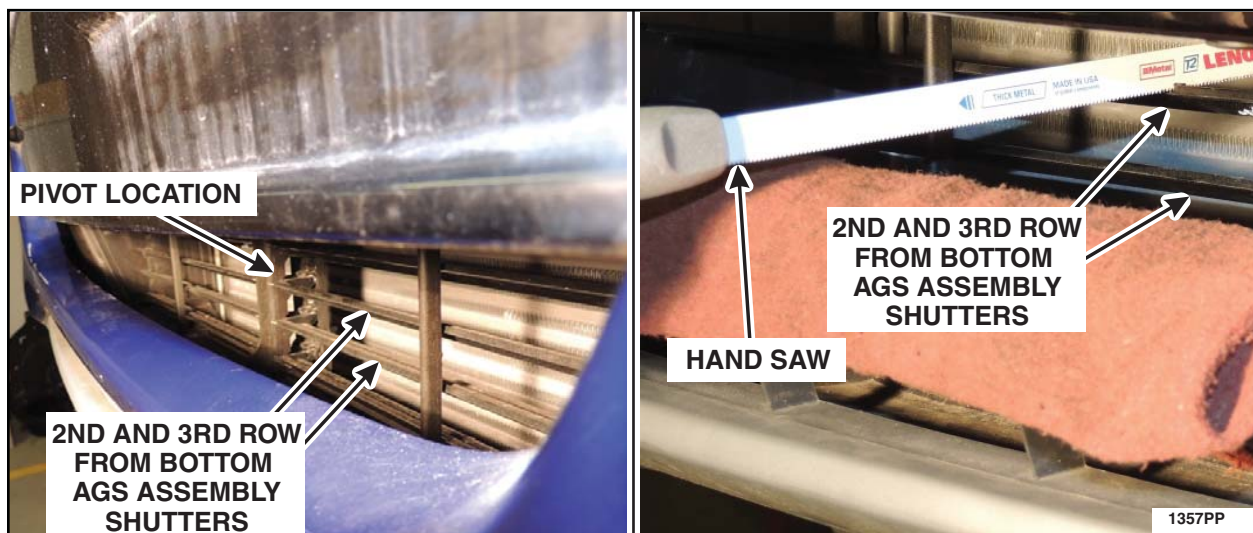

FIGURE L1

2. Remove the 2nd and 3rd row shutters from the lower AGS assembly through the lower front bumper grille opening. See Figures L1.
 - a. Cut through the 2nd and 3rd row shutters at approximately 2-inches from center on both sides of the AGS assembly.
 - b. Push the center portion of the 2nd and 3rd row shutters upward to disengage them from the center of the AGS assembly track.
 - c. Bend the detached center portion of the 2nd and 3rd position grill shutters back and forth to break them apart and remove them.
 - d. Slide the remaining LH and RH portions of the cut shutters out from their pivot locations at each side of the AGS assembly.
 - e. Verify all remaining shutters move and do not bind.



Procedure M - Battery B+ Terminal Cable Routing Inspection and Tie-Strap Retention

OVERVIEW: Ensure the battery positive cable to the generator is routed correctly. If routed incorrectly, the cable may contact and chafe at the transmission lifting eye on top of the transmission. Upon inspection, if the cable is routed incorrectly, it must be routed properly and secured to the engine main wiring harness using a tie strap.

PARTS / SUPPLIES REQUIRED:

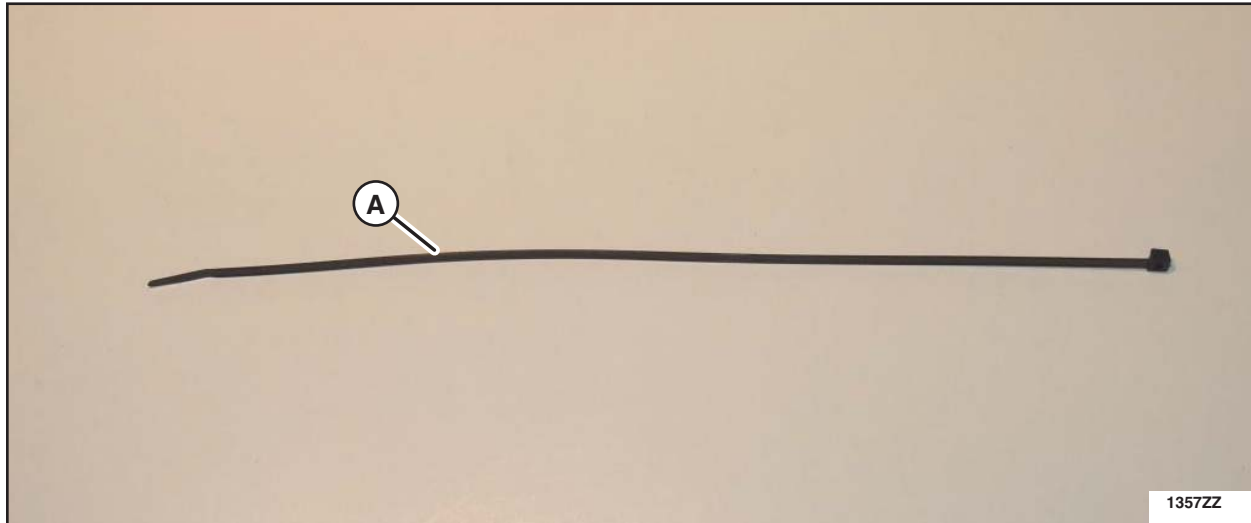

A	Tie-strap
---	-----------

UNIQUE TOOL REQUIREMENTS: None

SERVICE TIPS: None



1. Inspect the battery B+ terminal cable for improper routing and/or any signs of wire and insulation damage. See Figure M1.

- If the battery cable is damaged, replace it prior to proceeding.
- A **properly routed** cable can be identified by having the cable routed from the generator across the front of the engine and with the cable secured to the main engine wiring harness with a zip tie near the forward left side of the intake manifold. See Figure M1.
- An **improperly routed** cable can be identified by the cable being routed forward of the engine near the radiator, and is not attached to the main engine wiring harness with a zip tie. See Figure M2.

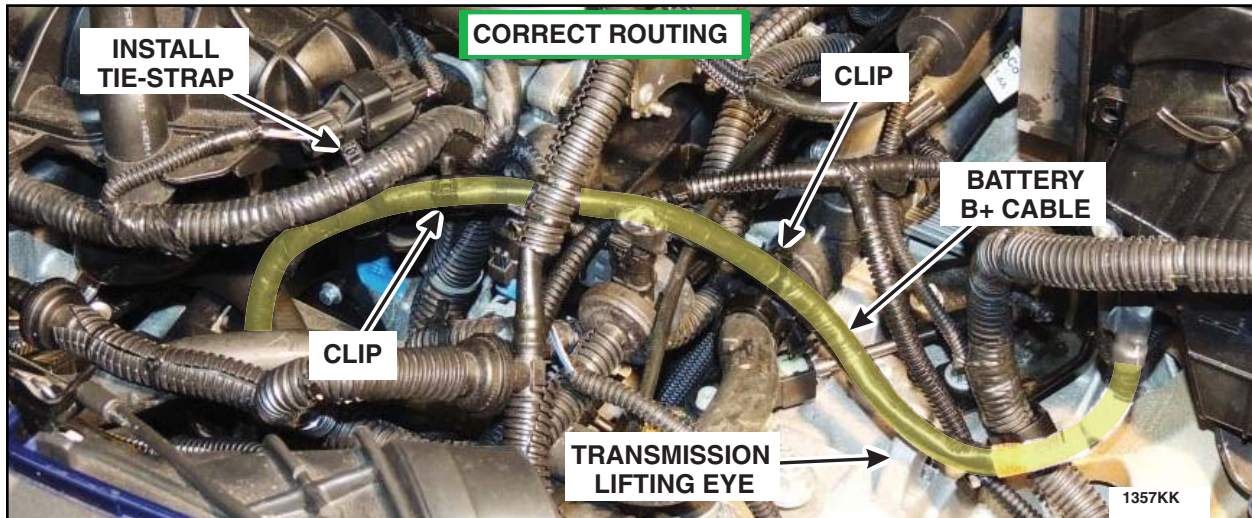

FIGURE M1

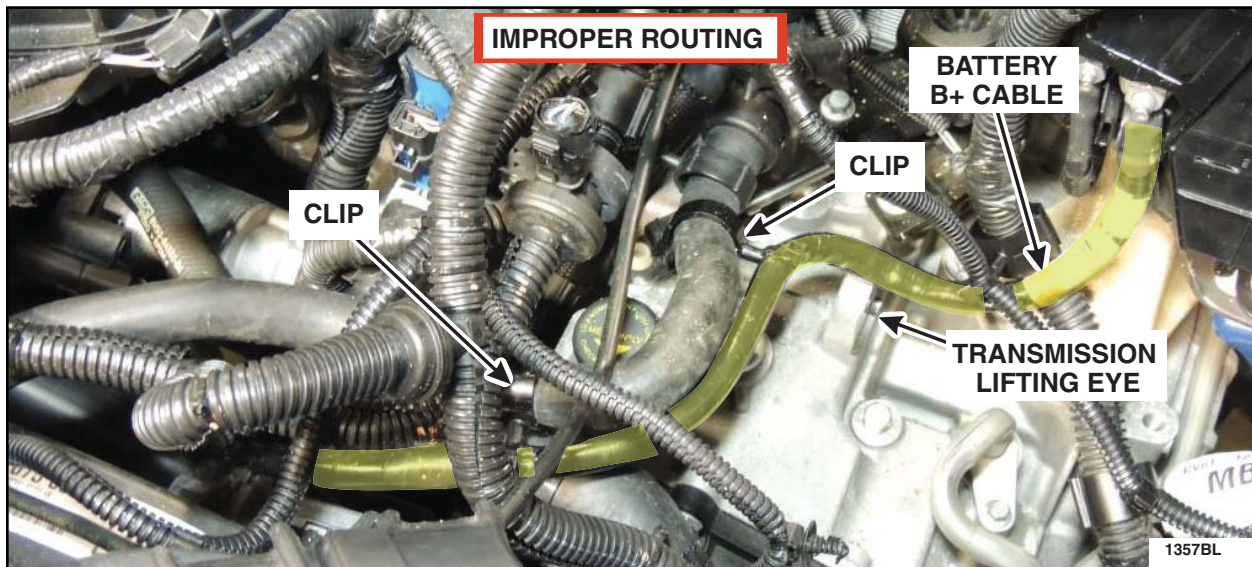

FIGURE M2



2. If the battery positive terminal cable is routed improperly and isn't damaged, pull it back through to the center of the engine compartment. Then re-route it up and near the front left side of the engine. Secure it to the main engine wiring harness using the tie-strap and existing clips as shown. See Figure M1.
 - If required to disconnect the battery B+ terminal cable for rerouting, the battery negative cable must be disconnected. For additional information, refer to WSM Section 414-01. Reconnect the battery after the rerouting and reinstallation of the battery B+ terminal cable is completed.
 - If removed, tighten the battery B+ terminal cable to 12 Nm (106 lb-in).
3. Install the tie-strap provided in the kit to secure the starter/generator battery positive cable to the engine wire harness and prevent the cable from contacting the transmission lifting eye. See Figure M1.



Procedure N - Vehicle Reassembly and PCV Tube Retention

OVERVIEW: The vehicle is reassembled, the cooling system is filled, pressure tested and bled; and a PCV tube retainer is installed. The PCM is reprogrammed and coolant level sensor operation is validated. The dipstick is replaced and an oil identification label is attached to the engine cover to complete the repair.

PARTS / SUPPLIES REQUIRED:

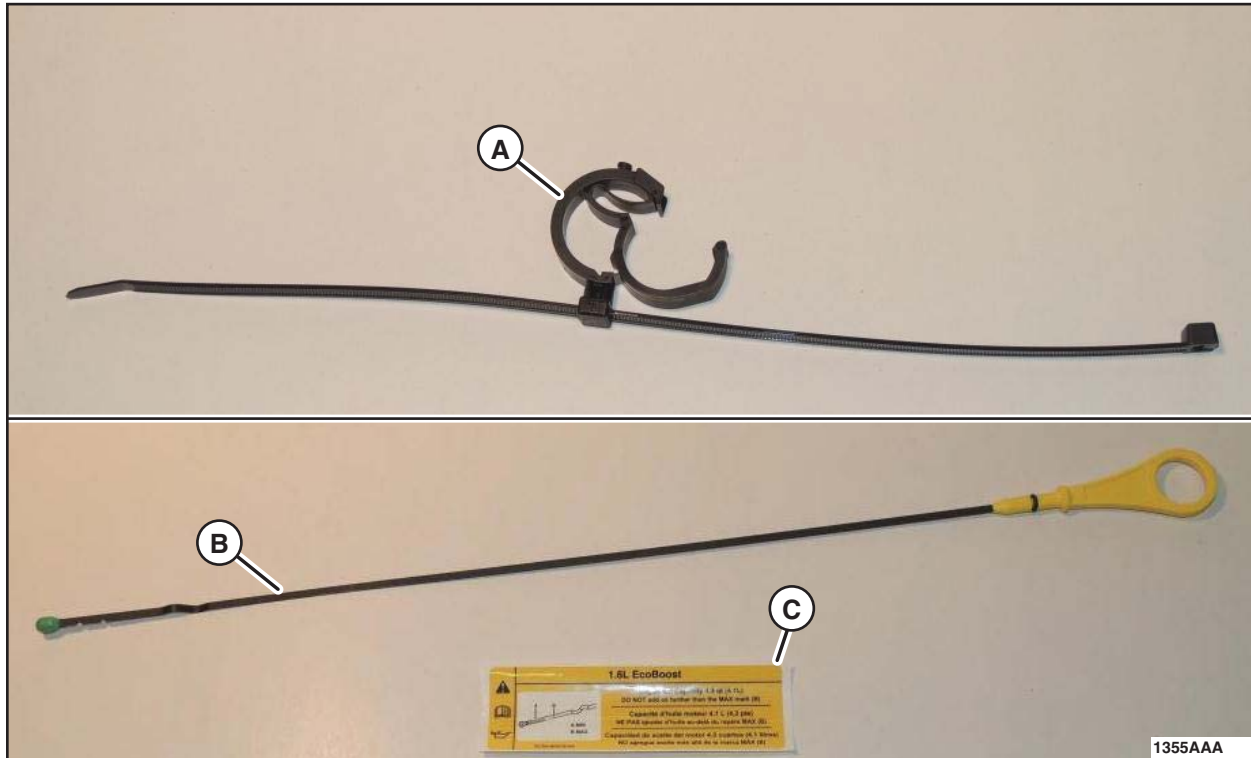

A	PCV Tube Retainer / Tie strap
B	Engine Oil Dipstick (Kit -6750-)
C	Engine Oil Fill Label (Kit -6750-)
D	Motorcraft® Metal Brake Parts Cleaner (PM-4-A or PM-4-B) (Dealer Procured) (Not Shown)
E	Motorcraft® Orange Antifreeze / Coolant Prediluted (VC-3DIL-B (U.S.) CVC-3DIL-B (Canada) / WSS-M97B44-D2) (Dealer Procured) (Not Shown)

UNIQUE TOOL REQUIREMENTS: None

SERVICE TIPS: Follow procedure steps to verify proper coolant fill.



NOTE: This procedure contains unique steps for reassembly, including installation of *new* components.

1. If disconnected previously, connect the battery B+ terminal cable.
 - a. Disconnect the battery negative cable to ground. For additional information, refer to WSM Section 414-01.
 - b. Install and tighten the battery B+ terminal cable to 12 Nm (106 lb-in).
 - c. Connect the battery negative cable to ground. For additional information, refer to WSM Section 414-01.

NOTE: Remove protective covers that were placed over the turbocharger air intake system before re-installing components.

2. Install the turbocharger inlet pipe and connect the PCV hose to the turbocharger inlet pipe. See Figure A3.
 - Tighten the turbocharger inlet pipe fasteners to 5 Nm (44 lb-in).
 - Tighten the turbocharger inlet pipe-to-turbocharger clamp to 5 Nm (44 lb-in).
3. Vacuum fill the cooling system. Refer to WSM Section 303-03 for coolant specifications.
 - Do not bleed the cooling system at this time.
 - Coolant level should be filled to the "MAX" mark on the degas bottle.
4. Install a coolant pressure tester with adapter onto the degas bottle. Pressurize to 138 kPa (20 psi). Once pressure stabilizes, pressure should hold at 138 kPa (20 psi) for a minimum of 2 minutes.
 - If pressure test fails, the source of pressure loss must be identified and repaired as appropriate before proceeding. Retest the cooling system, if required.
5. Vehicles built on or before July 11, 2012, AND identified in OASIS as having program code 13Y03 open, proceed to "Fuel Line Jumper Inspection" within Attachment V. Once complete, continue with procedure below.
6. Install the air cleaner assembly. See Figure A2.
 - a. Install the air cleaner assembly.
 - b. Attach the fresh air intake tube flap.
 - c. Connect the mass air flow sensor electrical connector.
 - d. Tighten the clamp to 5 Nm (44 lb-in).
7. Connect the EVAP line quick connect coupling to the air intake tube center section and install the retention clip. See Figure A1.



8. Install the PCV tube retainer / tie strap provided in the vehicle parts kit. See Figure N1.
 - a. Attach the clamp onto the PCV tube and secure.
 - b. Wrap the tie strap around the air intake tube center section and tighten.
 - c. Trim the excess length from the tie strap.

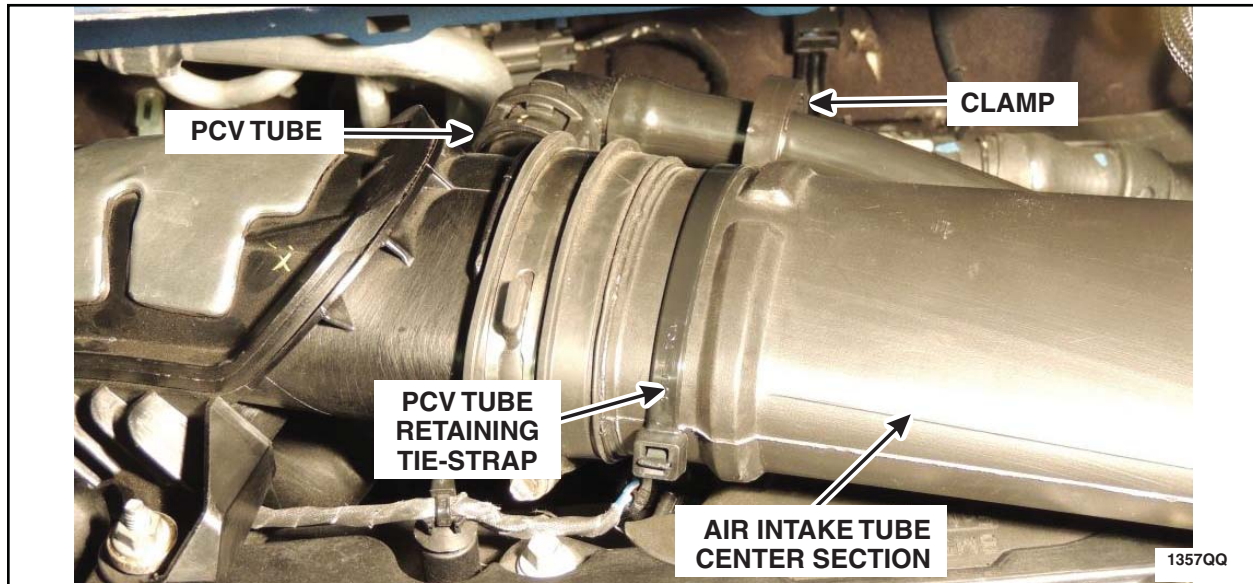

FIGURE N1

9. Install the front under-body air deflector and retainers. See Figure A4.
10. Bleed the cooling system. For additional information, refer to WSM Section 303-03A.
11. Reprogram the PCM using IDS release 89.04A or higher. For additional information, Refer to "Procedure F" (Important Information for Module Reprogramming).



12. Using IDS select "Coolant Level Sensor Check". See Figure N2.

- Follow the on screen instructions to complete the "Coolant Level Sensor Check" procedure.

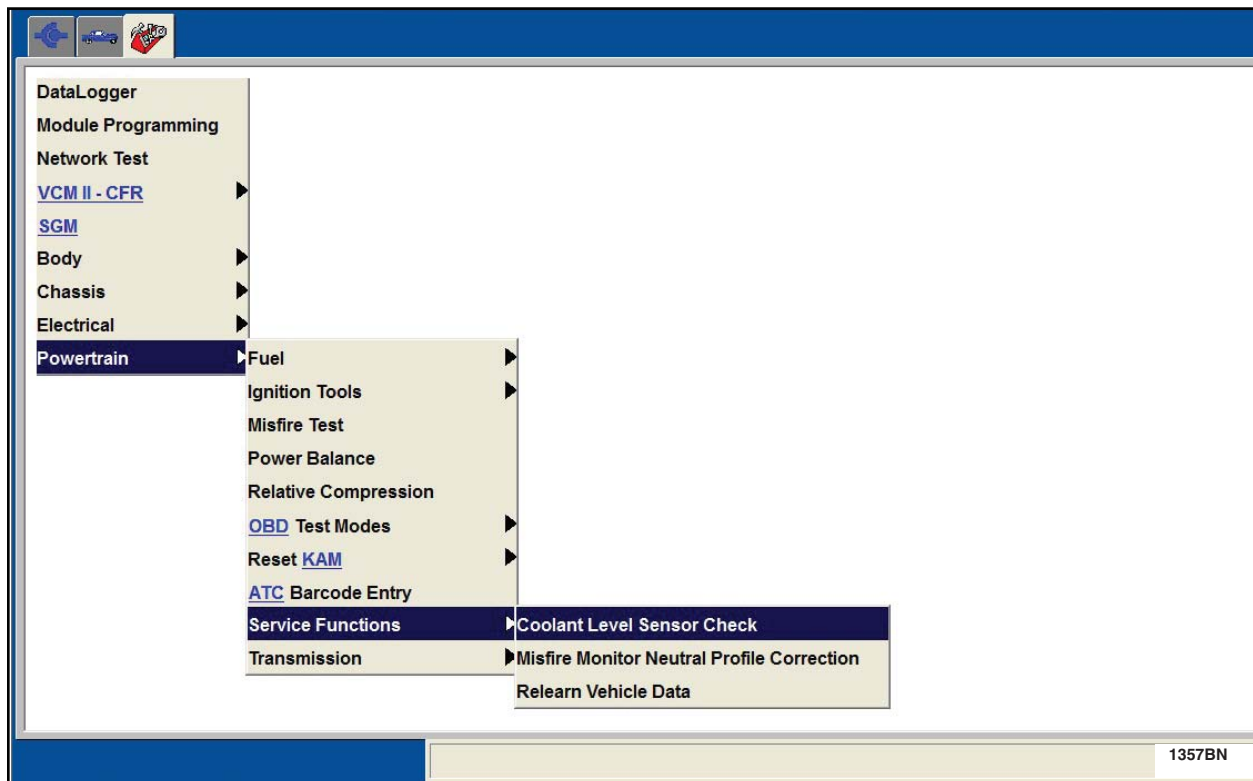

FIGURE N2

13. Remove the portable battery charger and install the battery cover.
14. Install the cowl panel. For additional information, refer to WSM, Section 501-02.
15. Install the engine appearance cover.



16. Clean the area on the engine appearance cover that the *new* engine oil fill label will be installed. Use Motorcraft® Metal Brake Parts Cleaner (PM-4-A or PM-4-B), and allow to dry. See Figure N3.

17. Install the *new* engine oil fill label onto the engine appearance cover as shown. See Figure N3.



FIGURE N3

18. Replace the vehicle's engine oil dipstick with the *new* engine oil dipstick. See Figure N3.

- Discard the original engine oil dipstick.

19. Verify that the engine oil level is correct, using the *new* engine oil dipstick.

- If the engine oil level is above the specified level on the *new* engine oil dipstick, adjust the engine oil level as appropriate using normal procedures.

20. Perform any other open recalls.

21. Coolant level should be filled to the "MAX" mark on the degas bottle once the engine is cold, prior to returning the vehicle to the customer.



Vehicle Identification Number (VIN)

--	--	--	--	--	--	--	--	--	--	--	--	--	--	--	--	--	--

13S12 VEHICLE INSPECTION / CHECK SHEET

ATTACHMENT IV
INSPECTION / CHECK SHEET
SAFETY RECALL 13S12

Technician ID: _____ Repair Order#: _____

Vehicle Mileage: _____ Repair Date: _____

Vehicle Build Date: _____ Open FSA(s): _____

INSTRUCTIONS: Complete this Inspection / Check Sheet and attach / file it with the recall repair order following completion.

1. Record any DTCs present. Check appropriate box.

- Pass - No DTCs present.
- Fail - DTCs present.

If fail, document any DTCs retrieved below, and reference during "Procedure B".

2. Visually inspect the coolant level in the degas bottle. Check appropriate box.

- Pass - Coolant level **is** visible in the degas bottle.
- Fail - Coolant level **is not** visible in the degas bottle, needed to add coolant.

If fail, document any repairs performed below.

3. Pressure test cooling system. Check appropriate box.

- Pass - Cooling system holds pressure for 2 minutes.
- Fail - Cooling system **does not** hold pressure for 2 minutes.

If fail, document any repairs performed below.

4. Visually check for coolant leaks with the system under pressure. Check appropriate box.

- Pass - No coolant leak(s) found.
- Fail - Coolant leak(s) found.

If fail, document any repairs performed below.

5. Visually inspect the engine oil level and check for engine oil leaks at the rear surface of cylinder head, above exhaust manifold. Check appropriate box.

- Pass - No engine oil leak(s) found.
- Pass - Correct oil level.
- Fail - Engine oil leak(s) found.
- Fail - Engine oil not at correct level.

If fail, document any repairs performed below.



CERTAIN 2013 MODEL YEAR ESCAPE VEHICLES EQUIPPED WITH A 1.6L ENGINE — FUEL LINE JUMPER INSPECTION

OVERVIEW

In certain 2013 Escape models equipped with a 1.6L engine built on or before July 11, 2012; the service fuel line jumper that was installed during Safety Recall 12S35 may have been installed incorrectly. An improperly positioned fuel line jumper may chafe on other engine components over a period of time and leak fuel.

At this time, dealers are to inspect the fuel line jumper for correct installation and replace it only if it is not installed properly.

Updated information for Safety Recall 13S12 will be provided to dealers late in the first quarter of 2014 when it is anticipated that repair instructions and parts ordering information will be available to support concerns for a risk of overheating that may result in engine fires.

SERVICE PROCEDURE

Fuel Line Jumper Inspection (Certain Vehicles Built On Or Before July 11, 2012 and Identified in OASIS by Program Code 13Y03)

1. Using OASIS determine if "Safety Recall 12S35" has been performed on the vehicle.
 - If "Safety Recall 12S35" **was not** previously performed (12S35 is open in OASIS), perform "Safety Recall 12S35" and also claim the "Inspection Passed" labor operation.
 - If "Safety Recall 12S35" **was** previously performed on the vehicle (12S35 is not open in OASIS), continue with this procedure to inspect the fuel line jumper.

NOTICE: When working with liquid or vapor tube connectors, make sure to use compressed air to remove any foreign material from the connector retaining clip area before separating from the tube or damage to the tube or connector retaining clip can occur. Apply clean engine oil to the end of the tube before inserting the tube into the connector.

NOTICE: Do not use any tools to disconnect the quick connect coupling on the air intake tube center section. The use of tools may cause a deformity in the clip components which may cause leaks.

NOTICE: Whenever turbocharger air intake system components are removed, always cover open ports to protect from debris. It is important that no foreign material enter the system. The turbocharger compressor vanes are susceptible to damage from even small particles. All components should be inspected and cleaned, if necessary, prior to installation or reassembly.

2. Remove the engine appearance cover.



3. Disconnect the EVAP line quick connect coupling from the air intake tube center section. Set the clip aside for re-installation to prevent it from falling into the engine compartment. See Figure 1.
4. Loosen the 2 clamps and remove the air intake tube center section. See Figure 1.
 - To install, tighten to 5 Nm (44 lb-in).

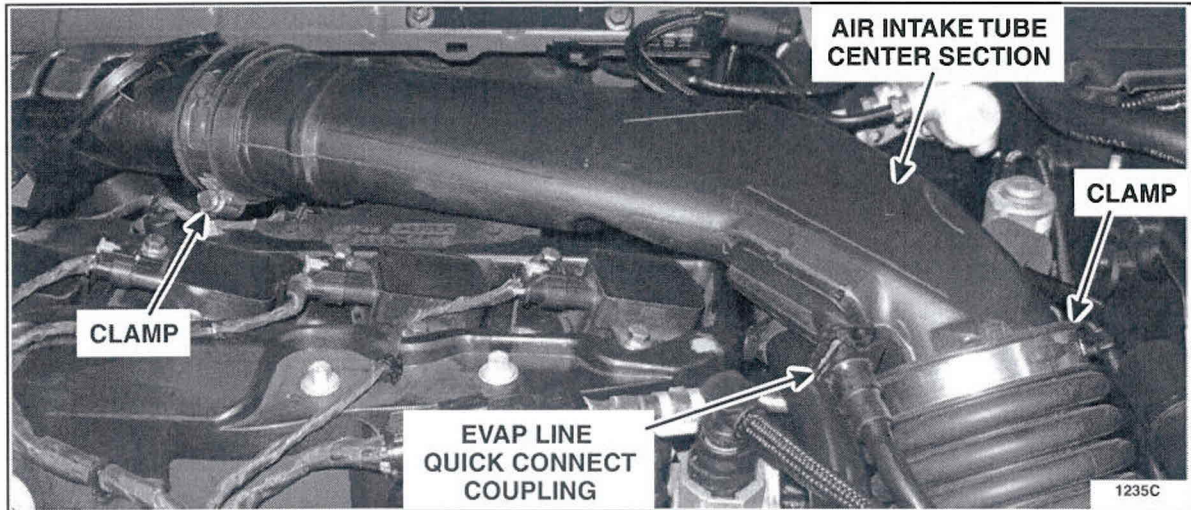

FIGURE 1



5. Inspect the fuel line jumper orientation. See Figure 2, 3, and 4.

- There are three different style service Fuel Line Jumpers that may have been installed during Safety Recall 12S35.

- **Type 1** - Plastic line with fuel pulse damper.
- **Type 2** - Plastic line without fuel pulse damper.
- **Type 3** - Plastic line without fuel pulse damper and with silver foil protective covering.

For all three of these line types, the correct installation is with the white "ENGINE SIDE" tag on the line closest to the engine connection side. See Figure 2, 3, and 4, for examples of correct installations.

- If the fuel line jumper **is** installed as shown, with the "ENGINE SIDE" tag located closest to the engine (front of vehicle), no further action is required. Reassemble the vehicle by reversing the removal procedure.
- If the fuel line jumper **is not** installed as shown, with the white "ENGINE SIDE" tag located closest to the engine (front of vehicle), proceed to "Fuel Line Jumper Replacement".

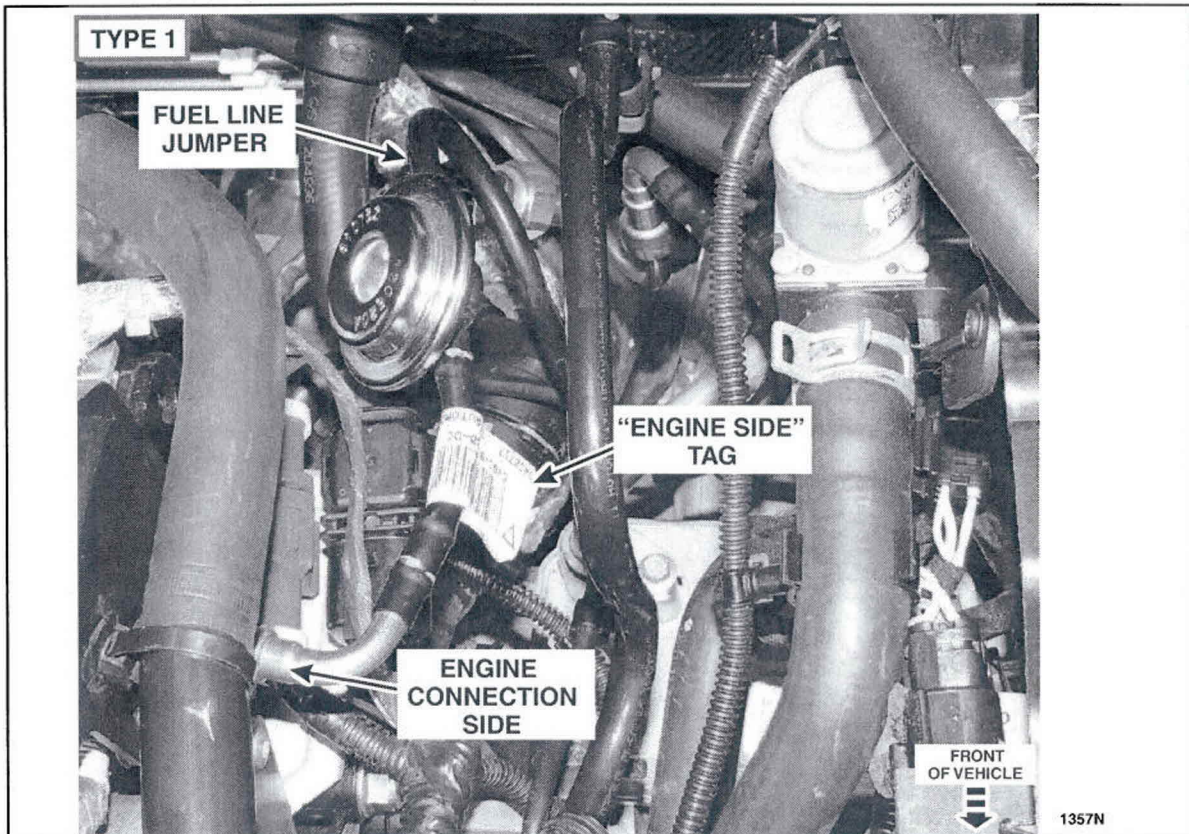

FIGURE 2



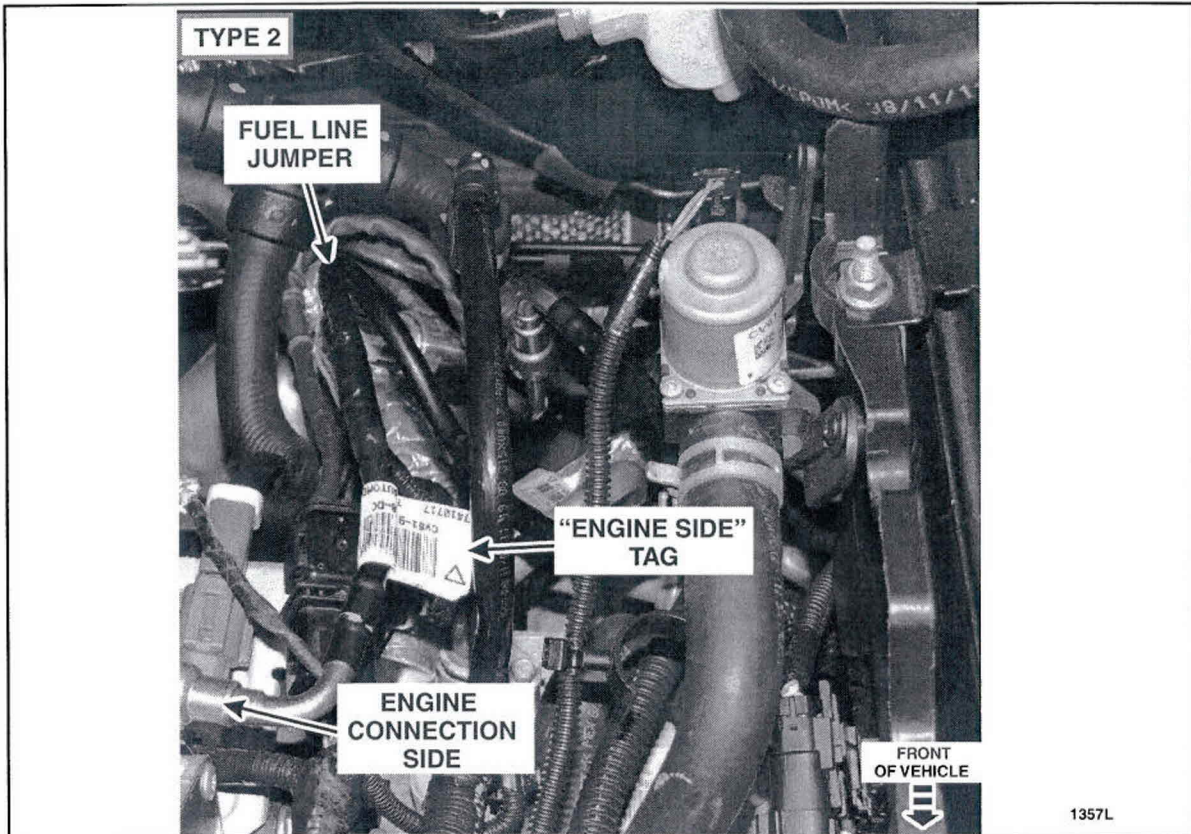

FIGURE 3

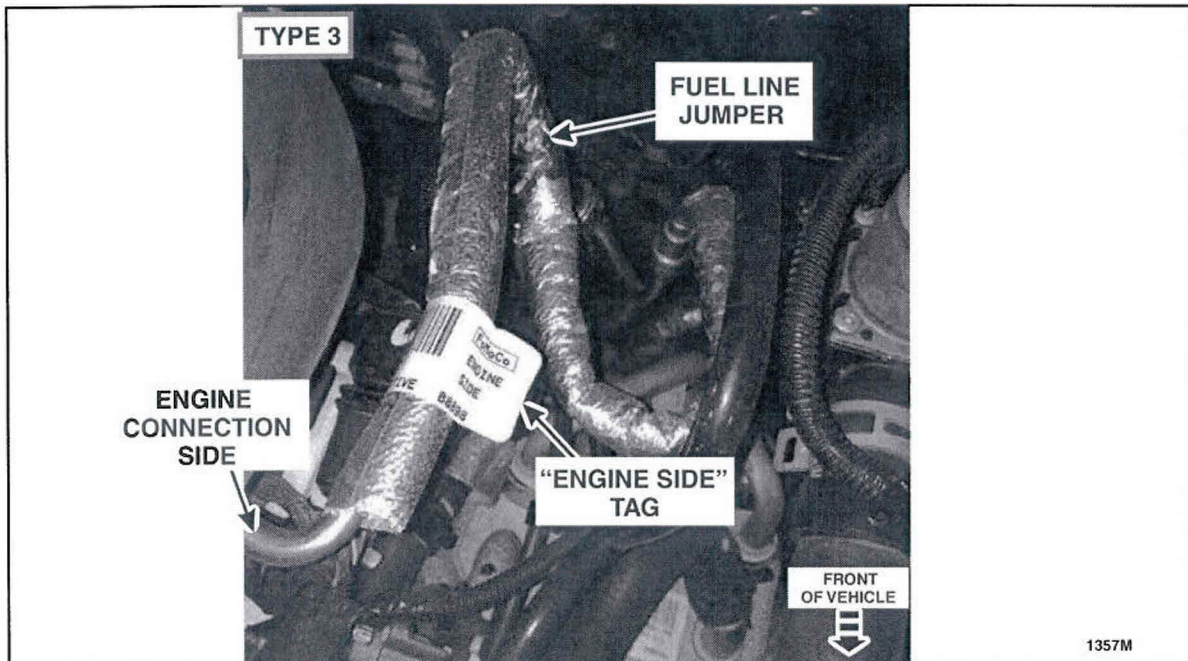

FIGURE 4



Fuel Line Jumper Replacement

⚠ WARNING: Before beginning this service procedure, review the Safety Warnings contained in Workshop Manual (WSM), Section 100-00.

NOTICE: Do not loosen any fittings or plugs on the fuel injection pump.

NOTE: The fuel line jumper should only be replaced if the existing line on the vehicle is verified to be installed incorrectly.

1. Remove the two retainers and the lower passenger side Instrument Panel (IP) insulator, to access the Body Control Module (BCM). See Figure 5.

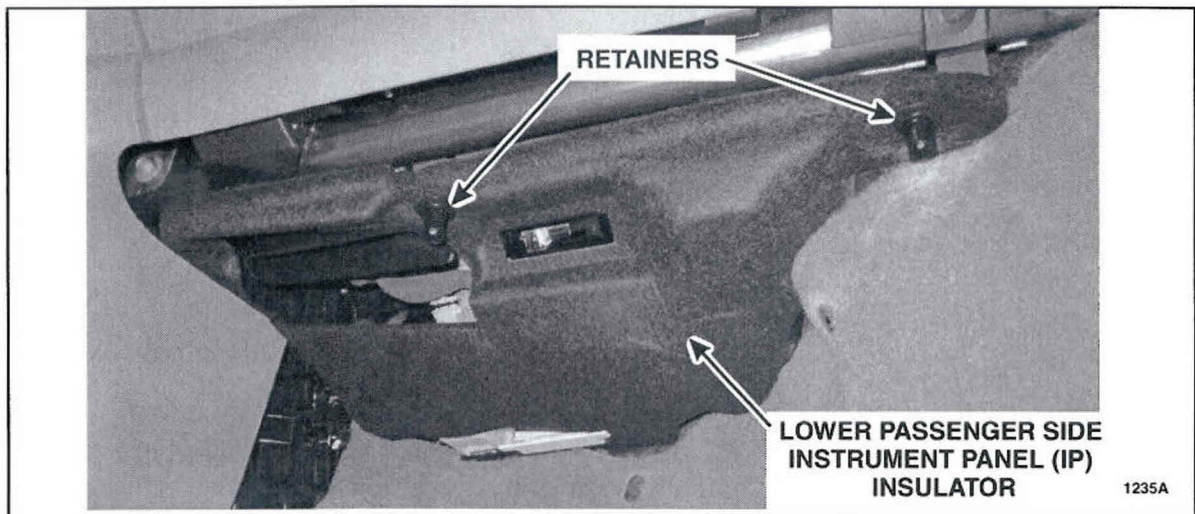

FIGURE 5

2. Remove Fuse #56 (Fuel Pump Module fuse), from the BCM. See Figure 6.

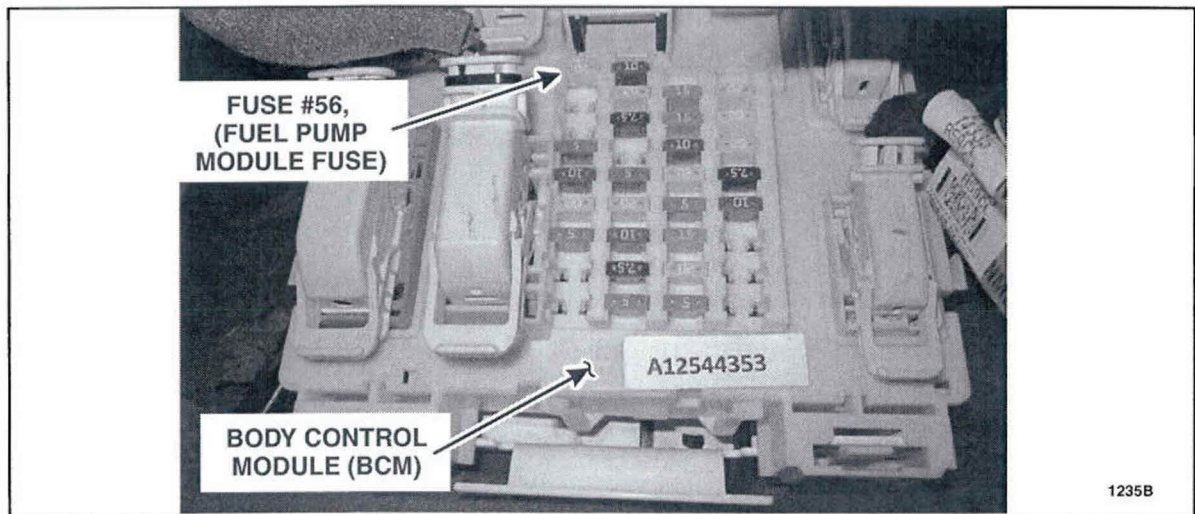

FIGURE 6



3. Start the engine and allow it to idle until the engine stalls.
4. Crank the engine for approximately five seconds to make sure that the fuel rail pressure is released.
5. Turn the ignition switch to the OFF position.
6. Disconnect the battery ground cable. Refer to WSM, Section 414-01.
7. Remove the two bolts and position the master cylinder reservoir aside. See Figure 7.
 - To install, tighten to 2.5 Nm (22 lb-in).

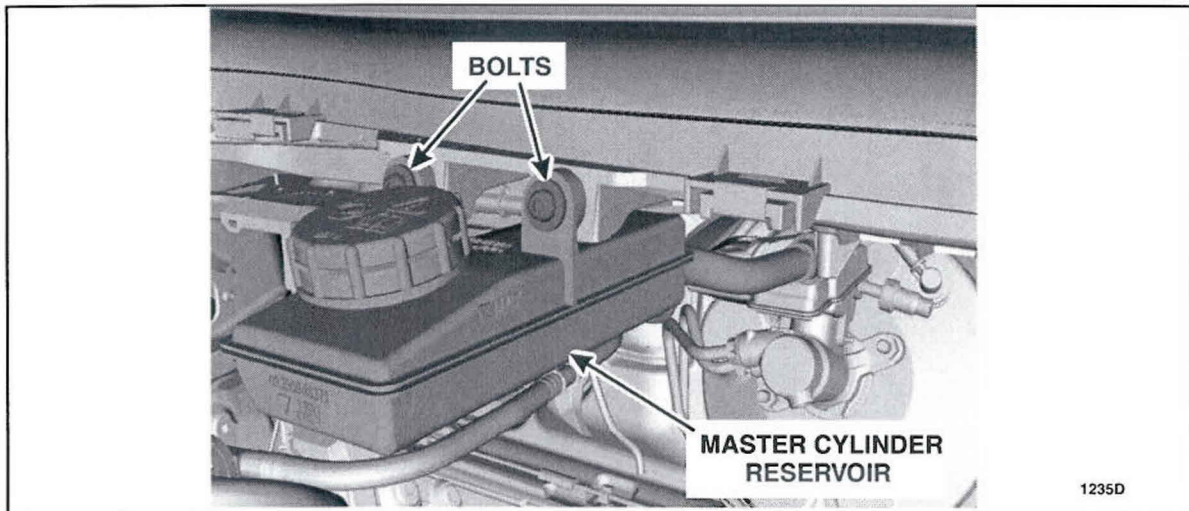

FIGURE 7



NOTICE: Fuel injection equipment is manufactured to very precise tolerances and fine clearances. It is essential that absolute cleanliness is observed when working with these components or component damage can occur. Always install plugs to any open orifices or tubes.

NOTE: Use a shop towel to absorb any residual fuel that is released when disconnecting the fuel lines.

8. Remove and discard the fuel line jumper. See Figure 8.

- Using Special tool 310-S039 or equivalent disconnect the fuel line quick connect couplings.

NOTE: The fuel line jumper shown is installed in the **incorrect orientation** with the "ENGINE SIDE" tag **not** located closest to the engine (further from front of vehicle).

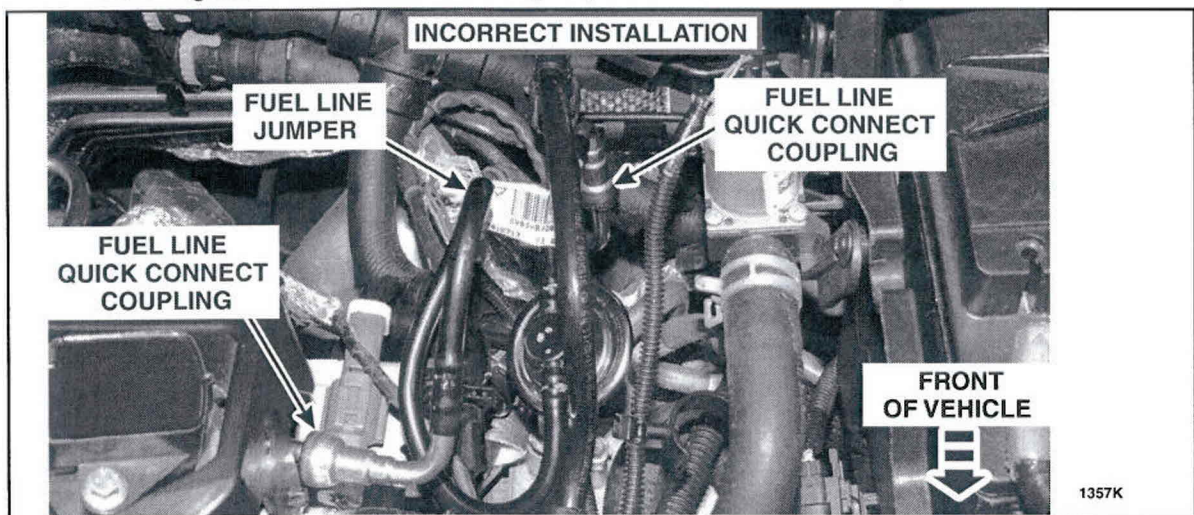

FIGURE 8



Fuel Line Jumper Installation

NOTE: The new fuel line jumper design does not have a fuel pulse damper.

NOTE: Once the fuel line jumper is installed, the yellow "ENGINE CONNECTION" tag should be positioned closest to the engine (front of vehicle). See Figure 9.

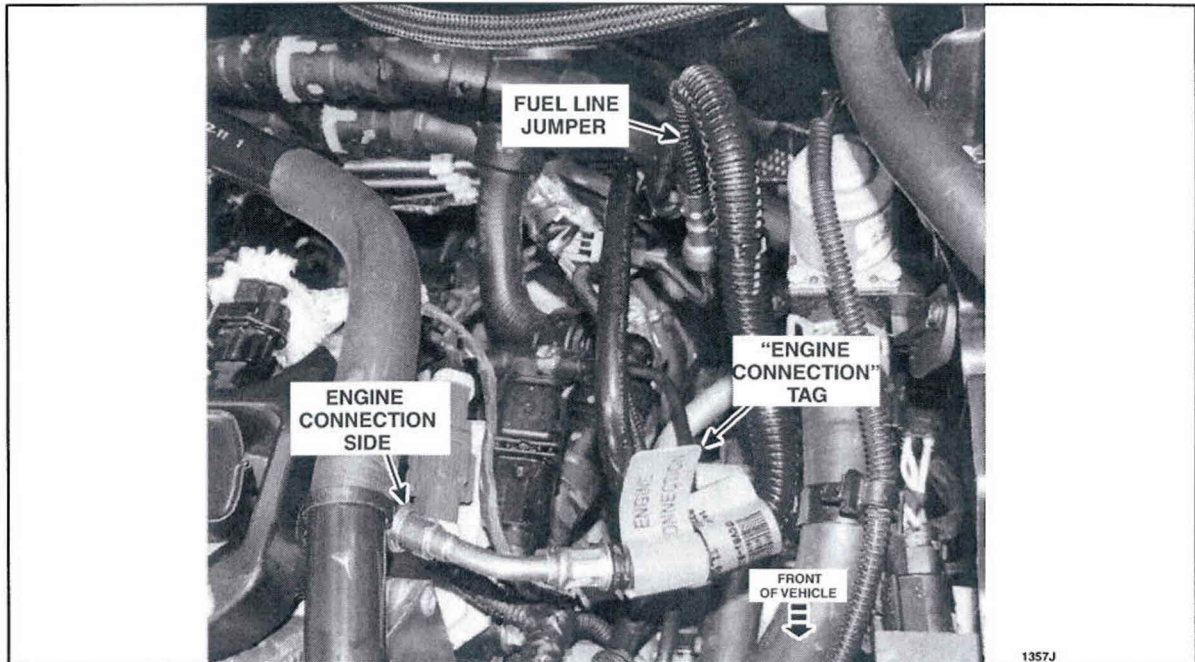

FIGURE 9

NOTICE: When connecting the *new* fuel line jumper, do not force it in at an angle or damage to the fuel line o-rings may occur. Minimal effort is required to connect the fuel line. If excessive effort is observed, re-align and try again.

1. To install the *new* fuel line jumper, reverse the removal procedure.

- Be sure that the yellow "ENGINE CONNECTION" tag is positioned closest to the engine (front of vehicle) before attachment. See Figure 9.
- Connect the engine side of the fuel line jumper first.
- Push the fuel line jumper connectors onto the lines. Listen for a click, then pull on the connectors to verify proper attachment.
- After installation is complete, carry out a Key ON Engine OFF (KOEO) visual inspection for fuel leaks.



13S12 SAFETY RECALL Supplement #1

DEMONSTRATION / DELIVERY HOLD / STOP SALE:

All 2013 Model Year Escape Vehicles Equipped with a 1.6L Engine - Risk of Localized Overheating of the

Safety Recall 13S12 Video Service Procedures:

Introduction/Procedure A – Initial Disassembly and Preparation for Inspection

Procedure B – Inspection and Check Sheet Completion

Procedure C – Cast Engine Shield Installation

Procedure D – Battery Tray Modification

Procedure E – Coolant Stand-pipe Wire Harness Installation

Procedure F – Instrument Panel Cluster (IPC) Reprogramming

Procedure G – Turbocharger Wire Harness Taping

Procedure H – Thermostat Replacement

Procedure I – Coolant Degas Bottle, Degas Bottle Cap, and Coolant Hose Replacement

Procedure J – Coolant Stand-pipe Installation

Procedure K – Front Under-body Air Deflector Modification

Procedure L – Lower Active Grille Shutter (AGS) Modification

Procedure M – Battery B+ Terminal Cable Routing Inspection and Retention

Procedure N – Vehicle Reassembly and PCV Tube Retention

e Engine Cylinder Head that May Lead to Oil Leak Fires

STOP SALE / DEMONSTRATION / DELIVERY HOLD – Safety Recall 13S12 – Supplement #1

All 2013 Model Year Escape Vehicles Equipped with a 1.6L Engine

Risk of Localized Overheating of the Engine Cylinder Head that May Lead to Oil Leak Fires

DEALER Q & A

Ford is taking precautions to protect its customers by conducting a safety recall of 2013MY Ford Escapes equipped with a 1.6L engine. Ford's investigation of these vehicles has identified a potential localized overheating of the engine cylinder head. The localized overheating may cause the engine cylinder head to crack, causing an oil leak that may result in a fire in the engine compartment.

- We are not aware of any injuries as a result of this condition.
- The fix will include enhancements to the engine shielding, cooling and control systems.
- A subset of these vehicles (built through July 11, 2012) will also be inspected to determine whether the engine compartment fuel line may have been installed incorrectly by service technicians in a previous recall. If installed incorrectly, the engine compartment fuel line could chafe over a period of time and leak fuel.
- Ford is committed to providing our customers with top quality vehicles. We are equally committed to addressing potential issues and responding quickly for our customers.

Additionally, some vehicles have been observed with an engine oil overfill condition that occurred during service when the oil capacity was not properly identified. An improved dip stick and label will be added to facilitate proper maintenance and improve customer satisfaction.

Q. What is the issue?

A. There is the potential for localized overheating of the engine cylinder head. The localized overheating may cause the engine cylinder head to crack, causing an oil leak that may result in a fire in the engine compartment.

Q. Is this the same issue as the earlier recalls for 2013 Escapes for potential fires?

A. No. Our extensive engineering analyses show there is a specific risk for localized overheating of the engine cylinder head. The localized overheating may cause the engine cylinder head to crack, causing an oil leak that may result in a fire in the engine compartment. The prior recalls were effective in addressing the other root causes.

Q. What is the recommended repair?

A. *The final repair will include enhancements to engine shielding, cooling, and control systems. An engine oil capacity label will also be installed and the dipstick will be replaced.*

Q. How should a Dealership prepare?

A. *Review the repair procedures which include 14 modular sub-procedures as identified in the technical information (Attachment III). Identify technician(s) to perform the repairs. Watch the instructional video and become familiar with the technical instructions and parts.*

Q. Why may it initially take additional time to complete the repairs?

A. *Due to the comprehensive technical instructions and repair procedures, initial repairs may take longer to complete. Over time, technicians will improve their productivity and reduce the time to complete the recall. To assist, we are allowing up to 2.0 hours of additional actual labor time to be claimed without prior approval.*

STOP SALE / DEMONSTRATION / DELIVERY HOLD – Safety Recall 13S12 – Supplement #1

All 2013 Model Year Escape Vehicles Equipped with a 1.6L Engine

Risk of Localized Overheating of the Engine Cylinder Head that May Lead to Oil Leak Fires

Q. Which vehicles require fuel line inspection?

A. If 13Y03 is open in OASIS for certain vehicles built on or before July 11, 2012; inspect the fuel line jumper for correct orientation and replace it only if it is **not** installed properly.

Q. Which vehicles require the thermostat to be replaced?

A. Vehicles built on or before April 19, 2013, will require thermostat replacement to improve cooling system performance. On these vehicles, the current part will be replaced with an 82 deg. C thermostat as used in vehicles built on or after April 20, 2013.

Q. Which vehicles will receive the dipstick and identification label?

A. All affected vehicles will receive a new dipstick and identification label to facilitate proper maintenance and improve customer satisfaction.

Q. When will parts be available?

A. Parts are available. Refer to the dealer bulletin for parts identification and order information.

Q. When do you plan to notify owners?

A. Owners of record were notified via first-class mail the week of January 20, 2014. Owners will be re-notified beginning the week of April 7, 2014 informing that parts are available and they should contact their dealership to schedule an appointment to complete the enhancements.

Q. Why aren't you advising customers to stop driving the affected Escape models when that was the course of action you took for a possible fire situation last year?

A. We implemented an improved control system to reduce the potential for severe engine overheats, detect severe overheats earlier and warn the driver to 'stop safely now,' both in production and in the field through our November 2012 recall (12S41). Owners are advised to maintain proper engine coolant level by following the Coolant Check procedure in the Maintenance section of the Owner's Manual to substantially reduce the risk of overheating leading to a fire.

Q. Are there any early warning signs or symptoms a customer would notice that would indicate a problem?

A. In addition to implementing an improved control system to reduce the potential for severe engine overheats and detect severe overheats earlier, we also implemented a warning for the driver to 'stop safely now,' both in production and in the field through our November 2012 recall (12S41).

Q. Is this a condition that can occur when the vehicle is turned off?

A. No.

Q. Is it safe for customers to park their vehicles in their garage?

A. Yes.

STOP SALE / DEMONSTRATION / DELIVERY HOLD – Safety Recall 13S12 – Supplement #1

All 2013 Model Year Escape Vehicles Equipped with a 1.6L Engine

Risk of Localized Overheating of the Engine Cylinder Head that May Lead to Oil Leak Fires

Q. In November 2012, you recalled both the 2013MY Escape and the Fusion for overheating conditions that may lead to an engine compartment fire. Why isn't Fusion included in this recall?

A. The engine application is different in the Fusion than the Escape. We do not see similar reports in the Fusion.

Q. Why aren't the 2014MY Escapes included in this recall? What's different?

A. In the 2014MY, we introduced a new engine temperature sensor. We are not aware of any reports of issues in 2014MY Escapes.

Q. Why don't you put that same sensor in the 2013MY Escapes?

A. The incorporation of the engine temperature sensor is not backwards compatible. *The updates in this recall will detect low coolant level and manage overheat conditions.*

Q. *How do we align scheduling of customer vehicles with shop capacity?*

A. *As the vehicle repairs will take about a day to complete, please plan accordingly and work with your Service Advisor team to schedule appointments. Dedicated technicians will become familiar with the repairs and complete the recall in less than a day. You are authorized to provide a rental vehicle up to 2 days while the vehicle is at the dealership for repairs.*