

## OC3 Seat Mat Modification for Passenger Seat, Sport Seat

### Preliminary work

Program and code the OC3 seat mat and then remove the passenger seat to modify the OC3 seat mat with no fault in the system.

Removing and installing/replacing the outer cover on the left or right front seat:

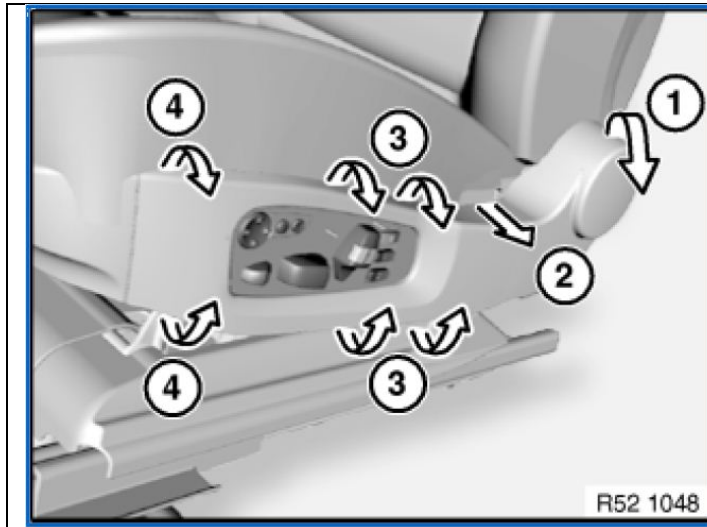

#### E60 and E61 only

- If necessary, move the seat fully forwards and upwards.
- Remove the trim:
- (1) Unclip at the rear towards the top side.
- (2) Pull on the belt opening to one side.
- (3) Bend the trim open slightly at the top and bottom on the actuating unit.
- (4) Bend open slightly at the top and bottom and pull outwards a little.

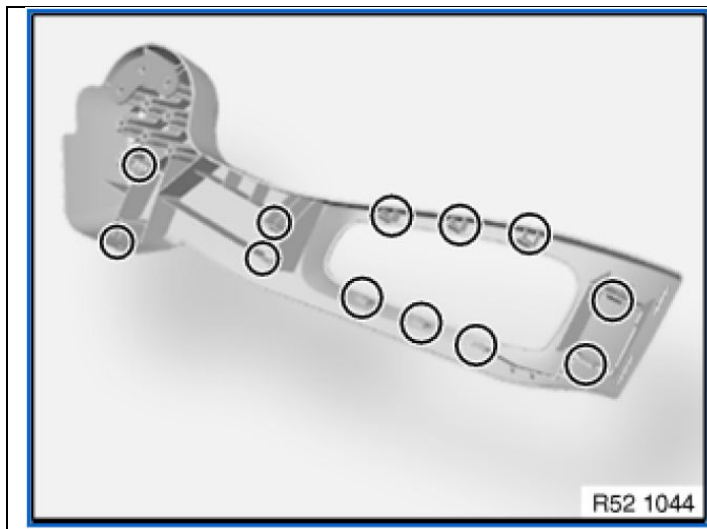

#### E60 and E61 only

- Check the retaining clips; they must not be damaged before installation.

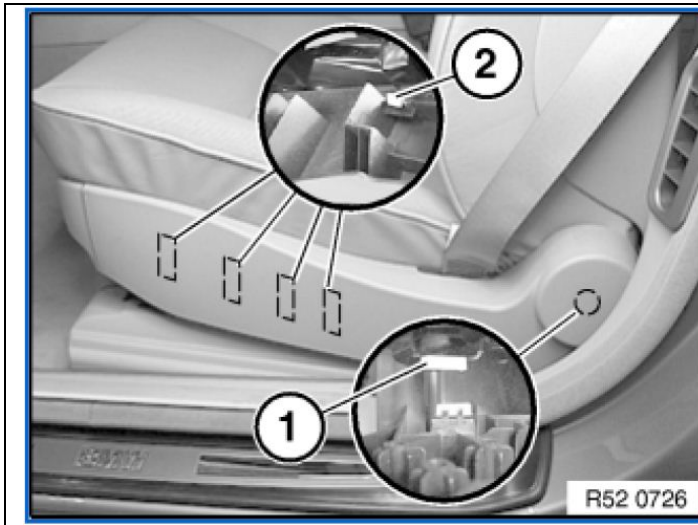

### E65 and E66 only

- Detach the cover from the retaining clip (1).
- Unlock the tabs (2) towards the bottom.

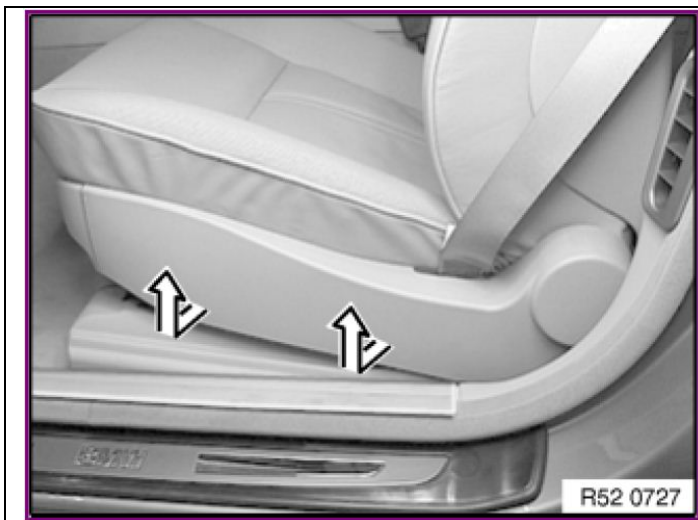

### E65 and E66 only

- Raise the seat cover from below and remove towards the top.

### Removing and installing/replacing the seat adjustment switch combination:

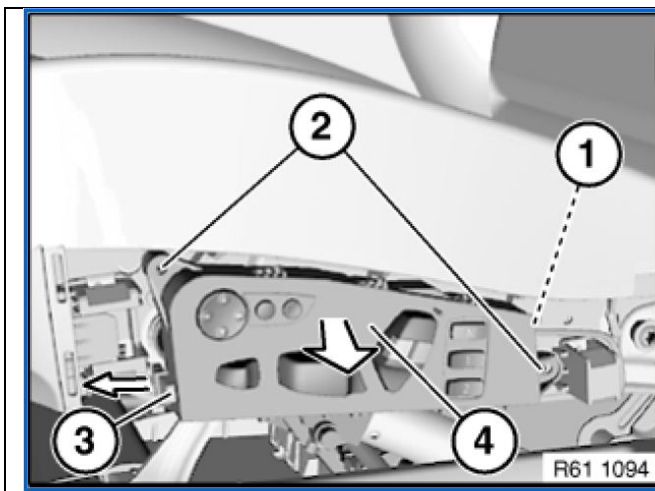

- Unfasten the plug connection (1) and disconnect.
- Loosen the screws (2).
- Unlock the catch (3) in the direction of the arrow and remove the seat adjustment switch combination (4) towards the front.

### Main Work

### OC3 mat modification procedure:

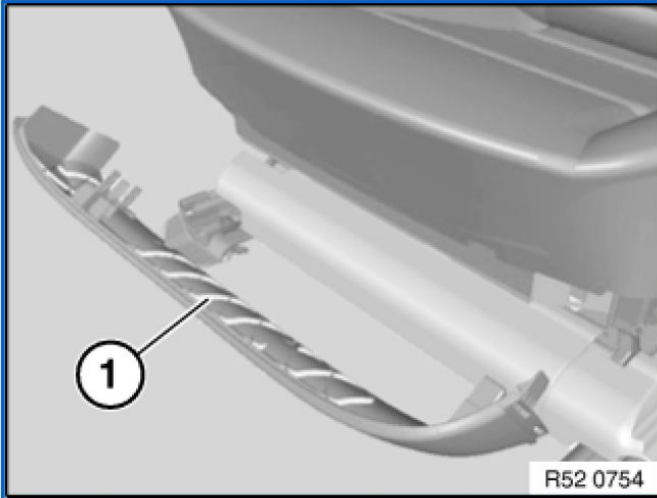

To avoid damaging the OC3 mat:

- Do not kink the OC3 mat.
- Handle the OC3 mat with extreme care.

Unclip the cover (1) on the front seat.

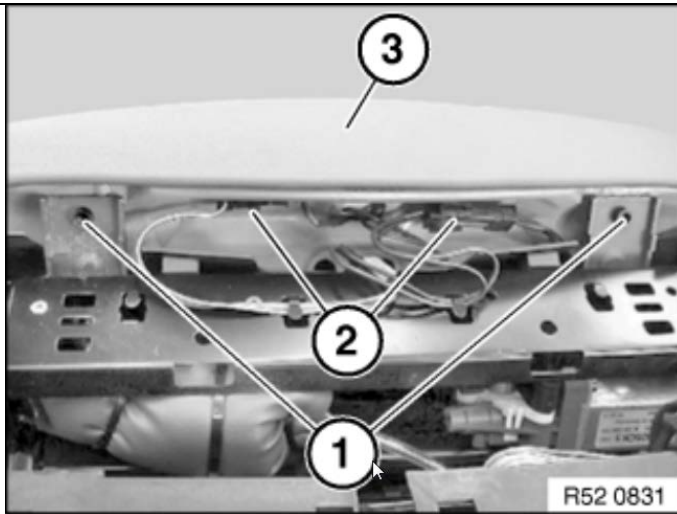

- Release the screws (1).
- If necessary, detach the plug connections (2).
- Remove the thigh support (3).

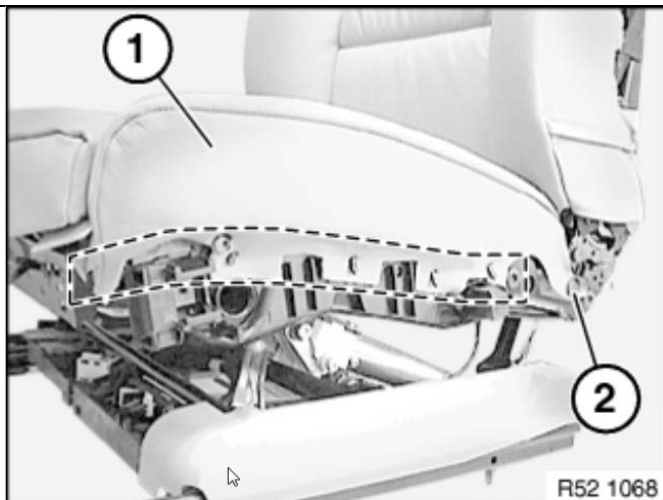

Note:

Operation is shown on the driver's seat as an example.

Unhook the seat cover (1) in the marked area on the exit side.

Take off the clip (2).

Installation note:

If necessary, replace the faulty clips (2).

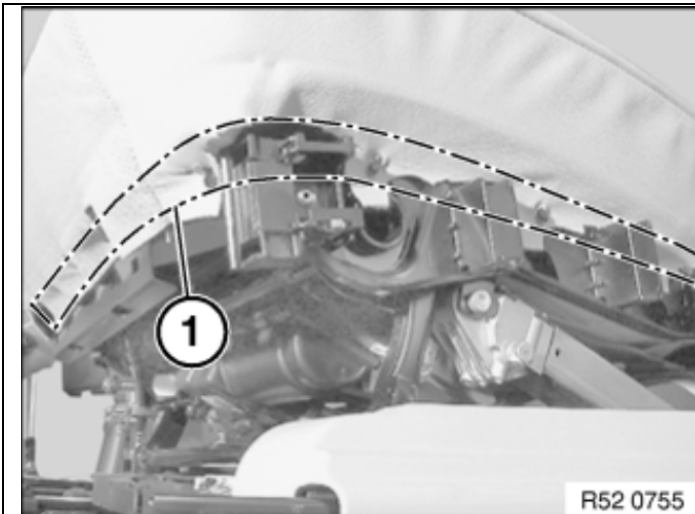

Detach the seat cover (1) in the marked area at all attachment points.

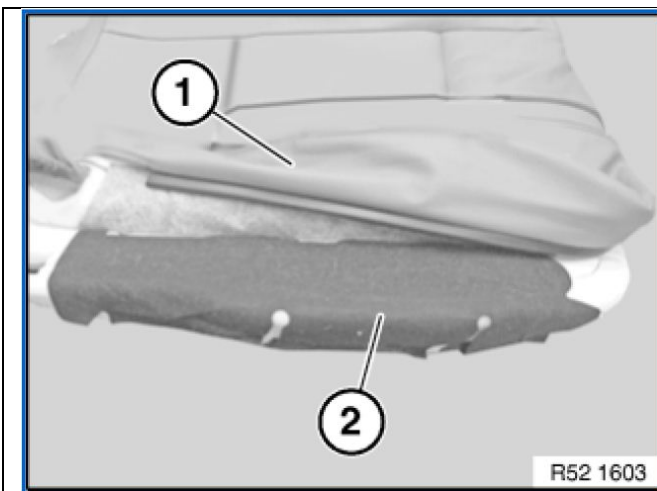

### Important!

The padding must not be damaged.

Fold back the seat cover (1) at the side.

Carefully detach the OC3 mat (2) from the side section of the upholstery.

If necessary, cut off the OC3 mat (2) with a heavy-duty knife without damaging the upholstery.

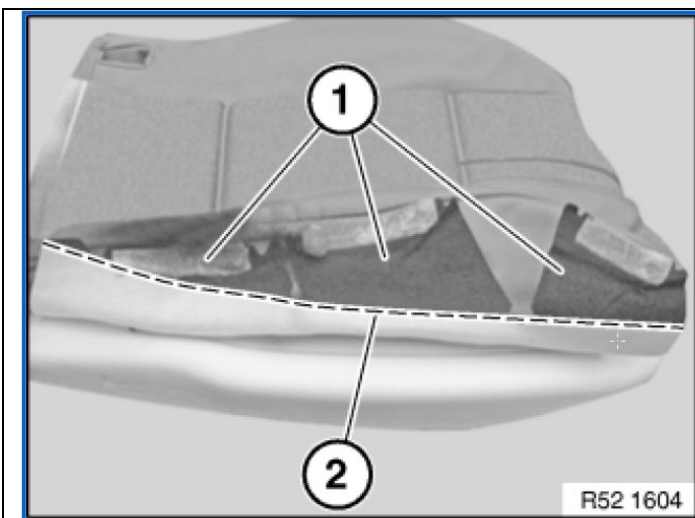

### Important!

Do not damage the strip conductors of the OC3 mat.

Carefully cut off the protruding material (1) of the OC3 mat above the contour (2).

Multifunction seat for the E65 and E66 only:

Pull off the lower protective film from the double-sided adhesive tape (2).

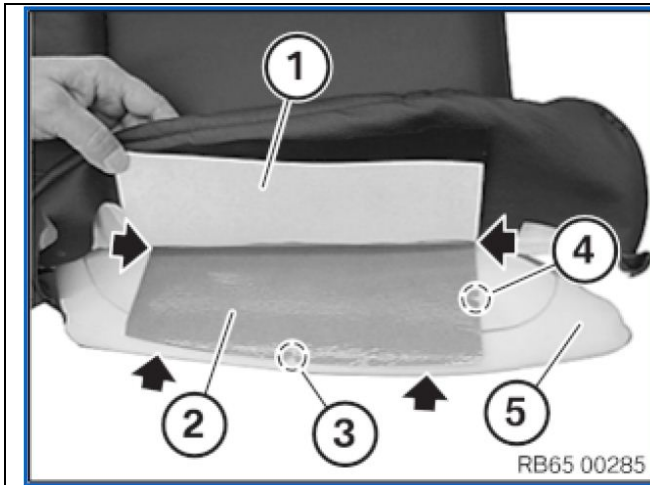

Fold back the OC3 mat (1).  
Position the double-sided adhesive tape (2) on the side section (5) as follows:

- The notch (4) must face forwards in the direction of travel.
- The notch (3) must face outwards in the direction of travel.
- Double-sided adhesive tape (2) must be flush with the OC3 mat (1) and with the side section (5), as shown by the arrow.

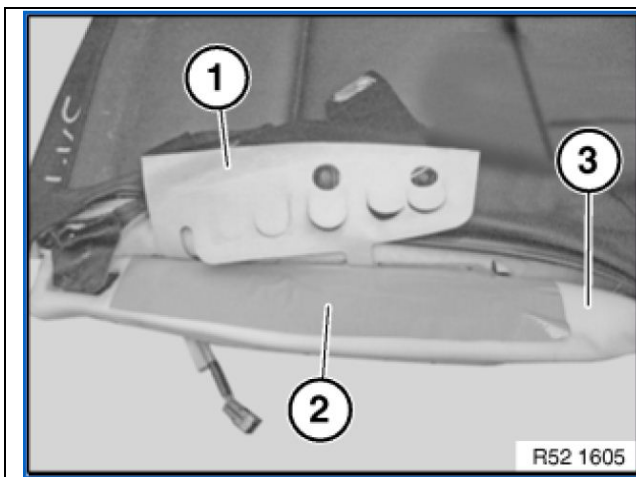

- Fold back the OC3 mat (1).
- Stick double-sided adhesive tape (2) to the upholstery (3).
- Pull the protective film off the double-sided adhesive tape (2).

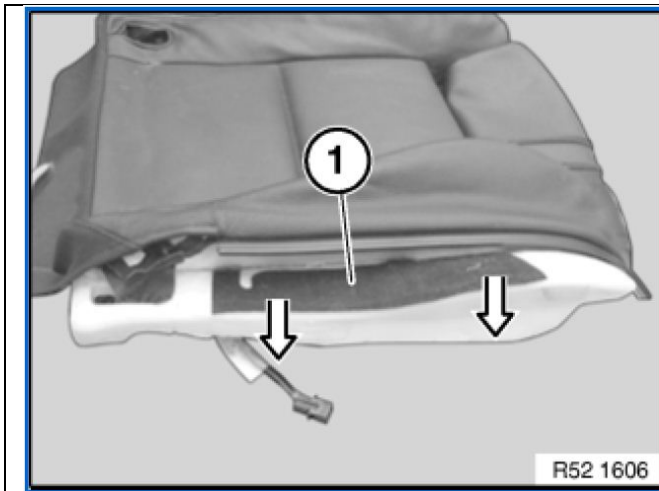

Pulling gently, stick the OC3 mat (1) to the side section.

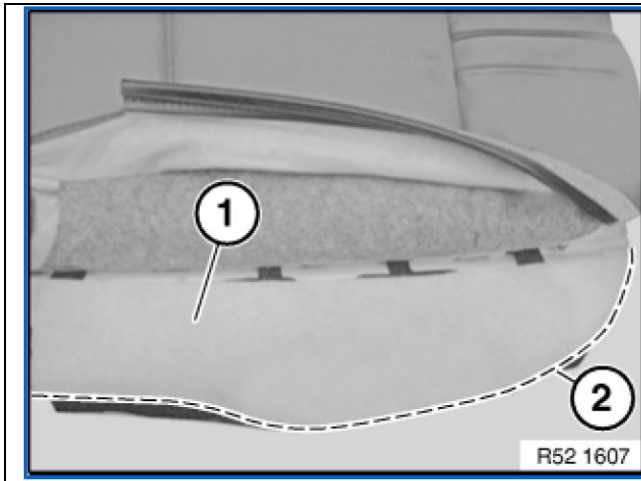

Stick the fleece (1) in the area of the OC3 mat to the side section.

Note:

Stick the fleece (1) to the side section edge (2) so that it is flush.

### **Concluding work**

Reassemble the seat after modification; reinstall the seat in the vehicle. Reconnect to ISTA and select the test plan for enabling the seat occupancy detection mat from the following path:

“Function selection → Service functions → Body → Seat occupancy detection → Program seat occupancy mat”

Select #2, "Enable seat occupancy detection" from the selection window.

**Follow the instructions in the test module.**

Complete the test plan and delete the fault code memory entries.