

## OC3 Seat Mat Replacement for Passenger Seat, Sport Seat

### Preliminary work

Remove the passenger seat:

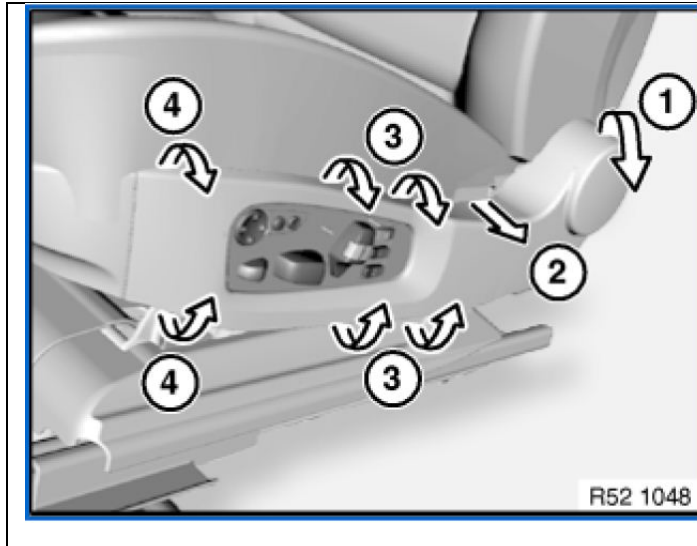

#### **E60 and E61 only**

If necessary, move the seat fully forwards and upwards.

Remove the trim:

- Unclip at the rear towards the top side (1).
- Pull on the belt opening to one side (2).
- Bend the trim open slightly at the top and bottom on the actuating unit (3).
- Bend open slightly at the top and bottom and pull outwards a little (4).

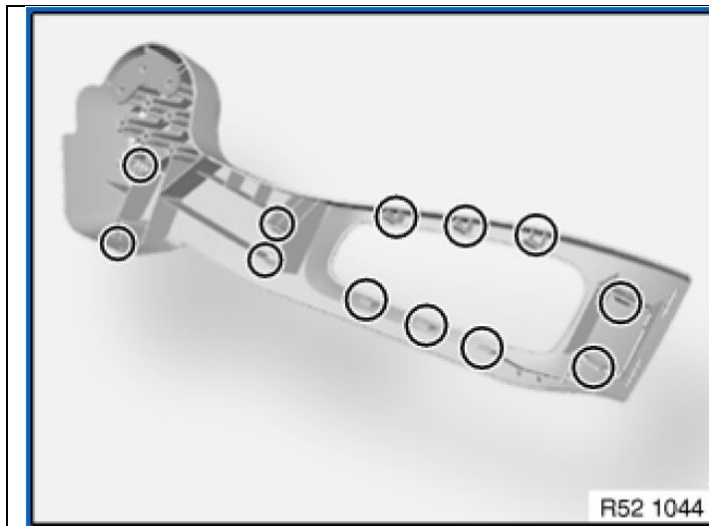

#### **E60 and E61 only**

#### **Installation:**

The retaining clips must not be damaged.

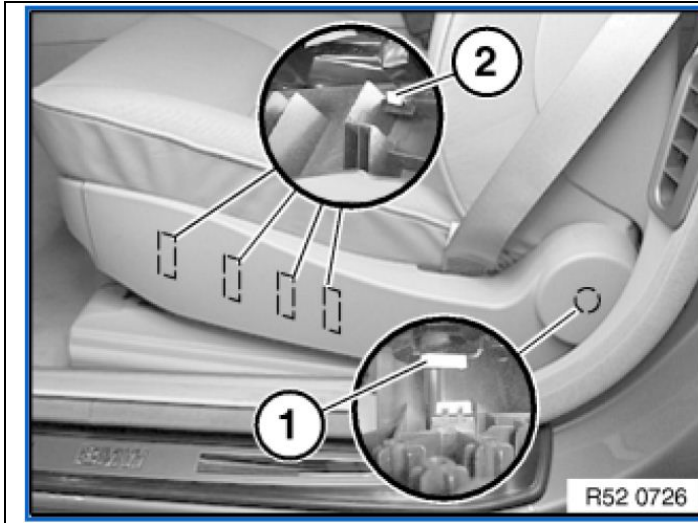

### E65 and E66 only

- Detach the cover from the retaining clip (1).
- Unlock the tabs (2) towards the bottom.

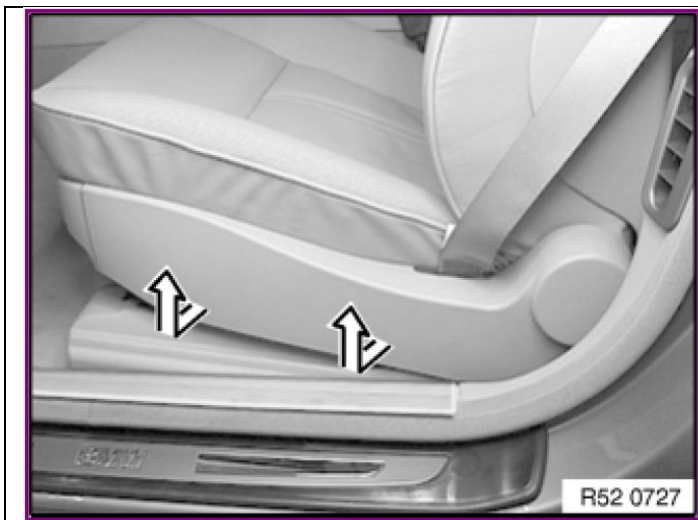

### E65 and E66 only

- Raise the seat cover from below and remove towards the top.

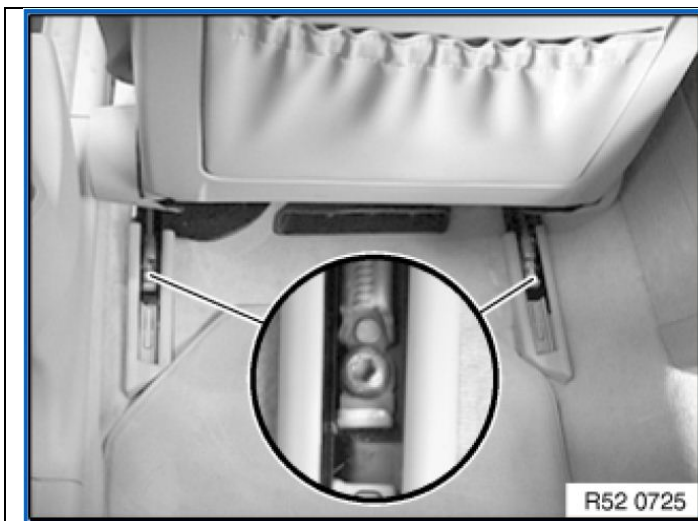

Adjust the front seat as far forward and upward as possible.

Release the screws.

### Installation note:

Make sure the end fitting (2) is correctly seated on the seat mechanism pin.

Tightening torque: **44 Nm**

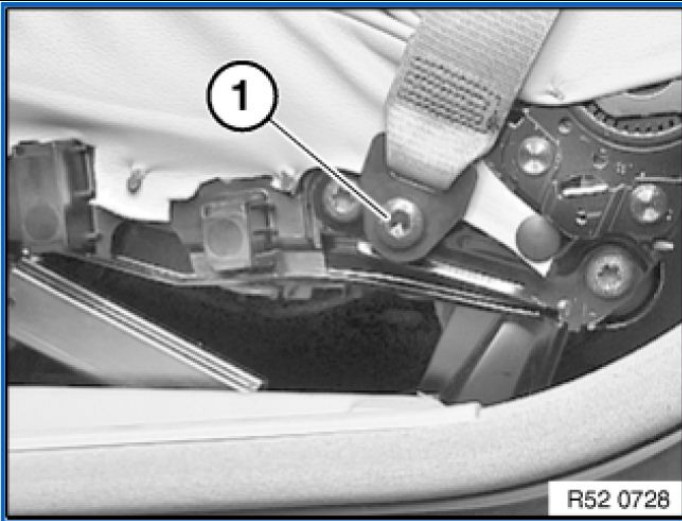

Release the screw (1) for belt mounting.

Installation:

Replace the bolts.

E60 and E61 only:

Tightening torque: **36 Nm**

E65 and E65 only:

Tightening torque: **44 Nm**

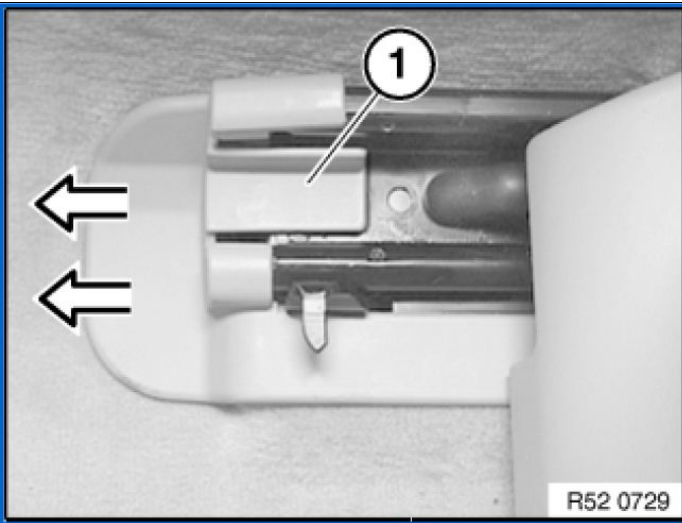

- Move the front seat as far back as possible.
- Raise the bridge (1) on the front right seat rail cover slightly and unlock.
- Pull the cover forwards to remove.

**Remove the rear panel on the passenger seat:**

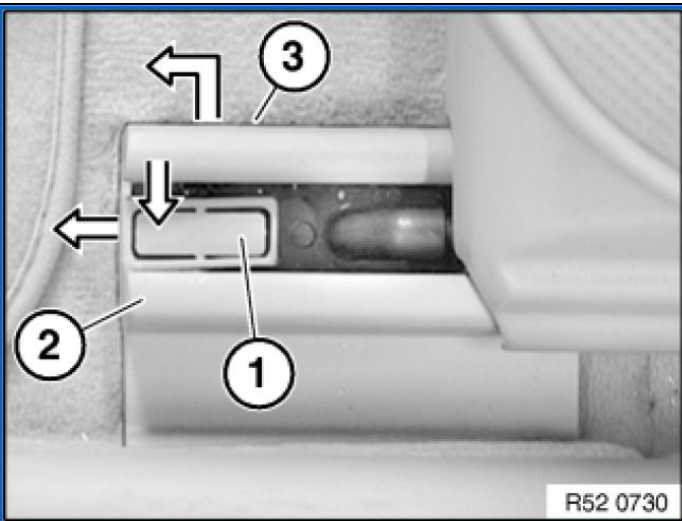

- Press the rocker switch (1) on the front left seat rail cover and unlock.
- Gently slide the cover (2) towards the front.
- Carefully unlock the inside edge (3) from the inside.
- Pull the cover forwards to remove.

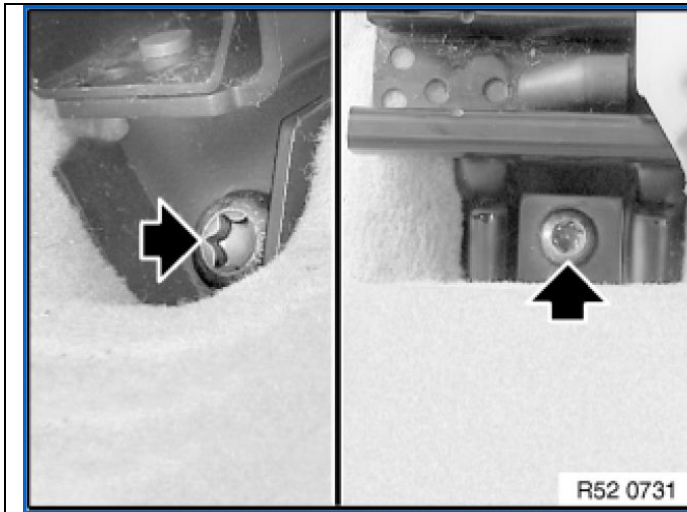

- Release the front screws on the left and right seat rails.

**Installation:**

Replace the bolts.

Tightening torques: **44 Nm**

The floor carpet must not project between the seat rail and floor board in the area of the screw-down points (grinding noises).

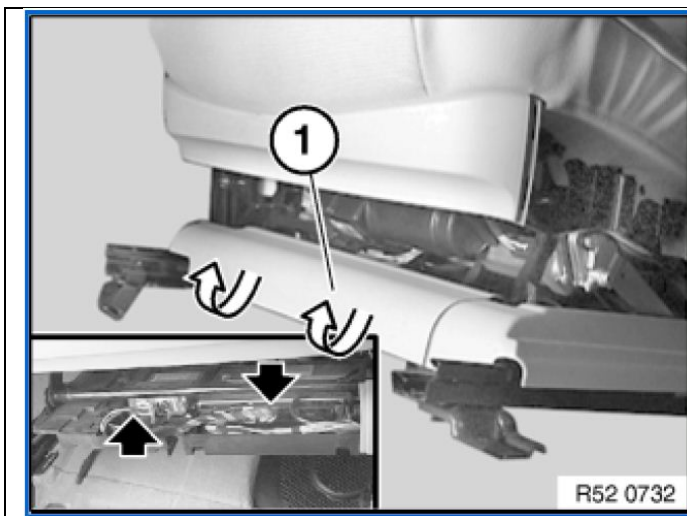

- Carefully tip the seat towards the rear.
- Unclip the cover (1) towards the front.
- Disconnect the plug connections (yellow and black) on the seat modules.

**Important!**

Remove the door sill with protective covers (damage to the vehicle).

Lift out the front seat.

**Removing and installing/replacing the rear panel on the left or right front seat backrest:**

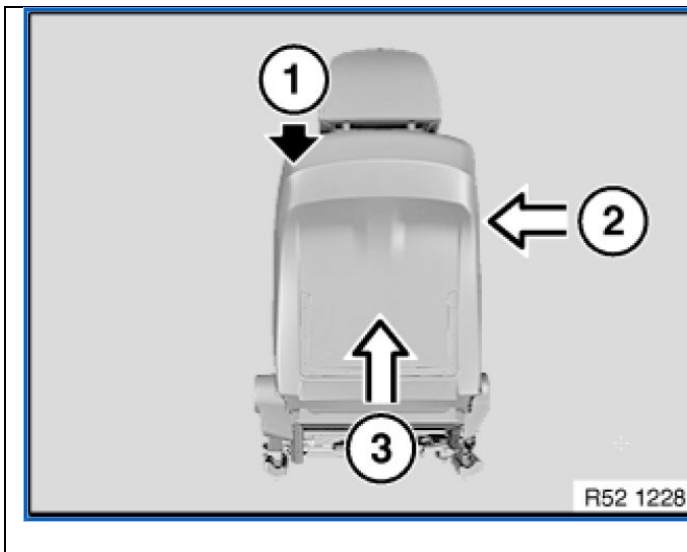

Operation is shown on the left seat.

When removing from the right seat, transpose the pull and striking sides accordingly.

1. Grip between the rear panel and backrest cover on the door side until the clip can be felt (do not pull).

2. At the same time, firmly punch towards the middle of the seat on the inner side (tunnel side) at the top.

The upper retainers spring out of the seat guide.

3. Pull the rear panel up out of the lower guides.

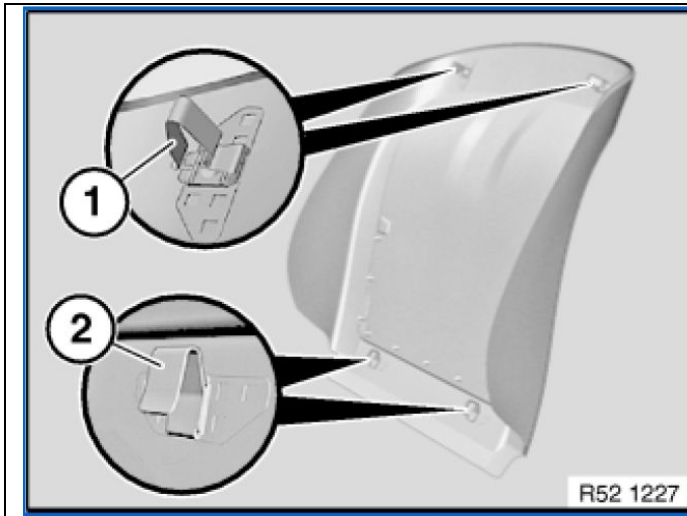

### Installation:

The rear panel and clips must not be damaged.

- (1) Upper clips
- (2) Lower clips

### Removing and installing/replacing the outer cover on the right front seat:

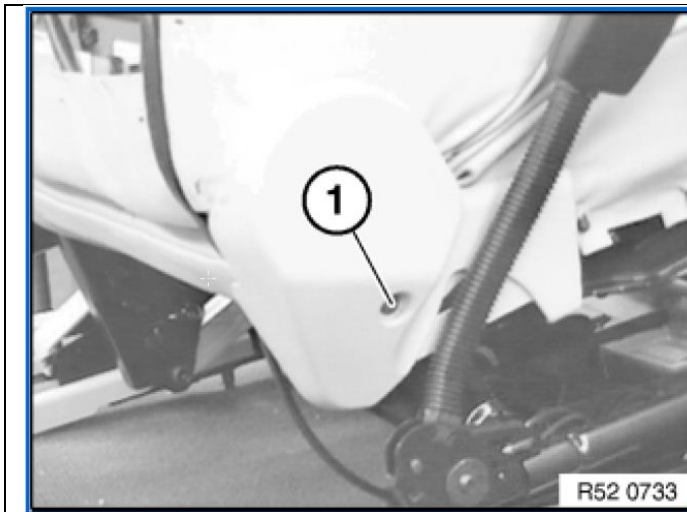

- Unscrew the bolt (1).

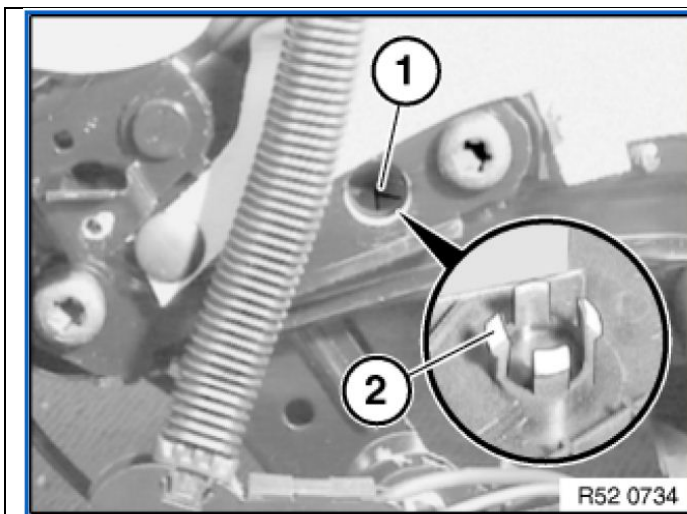

### Installation:

The cover is secured by the guide (2) in the hole (1).

### Main Work

The OC3 mat can only be removed in conjunction with the padding from the seat cover. If the OC3 mat or padding is defective, both parts may only be replaced together.

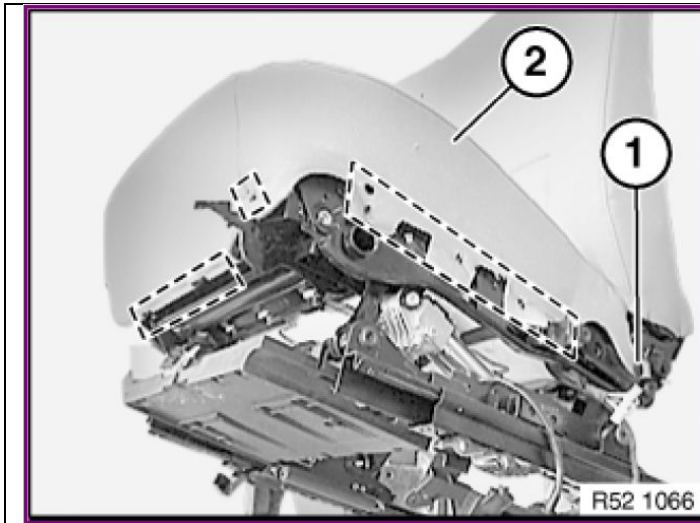

Unhook the seat cover (2) at all retaining points.

Lever out the left and right clips (1).

**Installation:**

If necessary, replace the faulty clips (1).

Remove the seat cover (2) with support. If necessary, disconnect all plug connections.

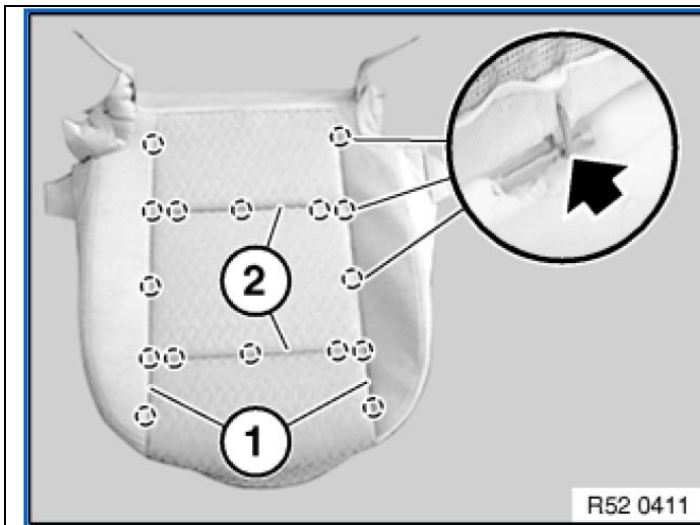

The OC3 mat must not be kinked under any circumstances.

Detach all retainers in the side area from the longitudinal wires (1).

Pull the trim wires (1) forward out of the seat cover.

Carefully fold back the seat cover and release the retainers from the cross-wires (2).

Remove the seat cover from the padding.

**Important!**

Remove all remnants of the clips from the seat cover and padding.

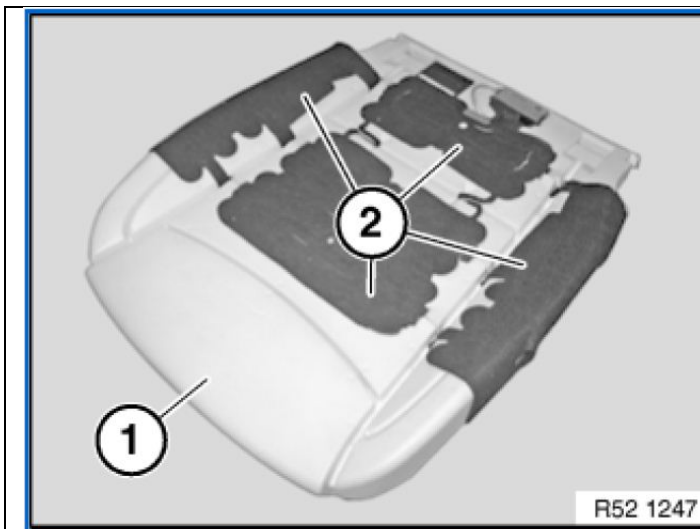

The new replacement padding (1) comes attached to the OC3 mat (2).

**Important!**

- No retainer remainders may be fitted.
- Handle the OC3 mat with extreme care.
- Do not kink the OC3 mat.
- Do not clamp the OC3 mat.
- The OC3 mat must lie without folds under the seat cover.

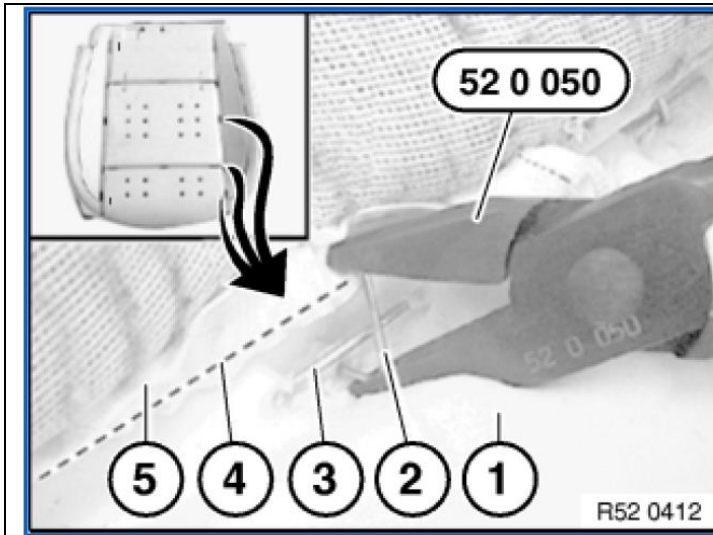
**Installation:**

Bend the new retainer (2) closed with special pliers.

- Padding (1)
- Clips (2)
- Trim wire in the seat cover (3)
- Trim wire in the padding (4)
- Seat cover (5)

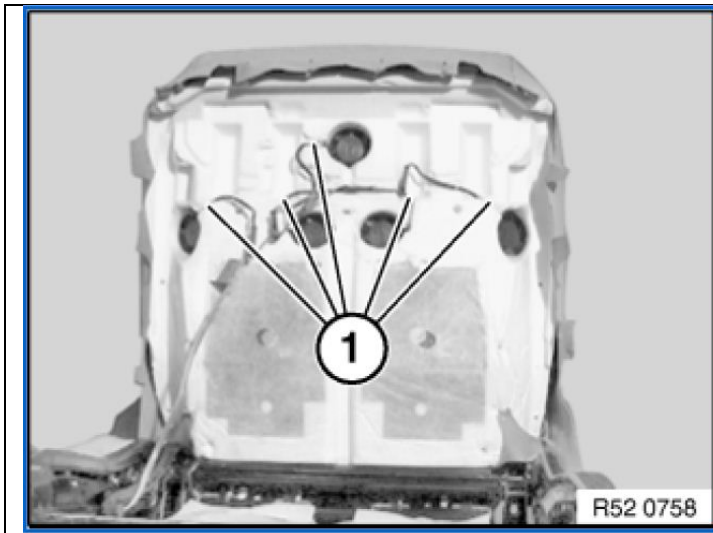
**Note:**

For seats with air conditioning, remove the A/C fan from the support reinstalled to the new seat mat.

**Installation:**

Make sure the fans have correct cable routing (1).

**Concluding work**

Reassemble the new OC3 seat mat with the seat cover. Reinstall the seat in the vehicle and connect the cable to the vehicle.

Four Powerlok screws must be replaced and not reused. Tightening torque: **44 Nm**

Release the screw for the belt mounting for the tightening torque: **36 Nm** (E60/E61)  
Tightening torque: **44 Nm** (E65 and E65)

The floor carpet must not project between the seat rail and floor board in the area of the screw-down points (grinding noises).

**Programming routine via ISTA/P:**

- Connect the battery charger to the vehicle.
- Connect the programming system to the vehicle.

- Determine the action plan.
- Accept the action plan with the control units to be programmed/encoded and enabled, if necessary, or work through.
- Observe the reworking list!
- If applicable, connect the workshop system to the vehicle. Depending on the rework list, run the brief test and delete the fault memory.

Note:

A switch to the workshop system may not necessarily be required with the integration of the service functions and the "Delete fault memory" functions in ISTA/P. Check the rework list accordingly!

- Compliance with the information about programming in workshop systems, and the corresponding notes in the user documentation, is required.