

Parts Kit C, P/N 59000-01830-RX0

2005-2006 GSX-R1000 Front Master Cylinder and Brake Hose

No. 1 Installation Guide

1. Preparation

REPLACEMENT PARTS

Part Name	Qty	Description
Cylinder kit, FR MASTER	1	Master cylinder set, P/N 59601-47H30 x1 Bracket, reservoir tank, P/N 59751-37H00 x1 Brake Hose No.1, P/N 59480-29G10 x1 Washer, brake hose, P/N 09161-10009 x5 Bolt, reservoir tank, P/N 09111-05006 x1 Nut, reservoir tank, P/N 09159-05048 x1 Nut, brake lever, P/N 57433-09F00 x1

TOOLS AND LUBRICANTS NEEDED:

- Screwdriver (Phillips No. 2 & flat blade No. 3)
- Hexagon socket wrench (4mm)
- Socket wrenches (8, 10, 12mm)
- Wrenches (8, 10, 12mm)
- Ratchet, extension bar for ratchet, torque wrench
- Parts cleaner, clear hose, receptacle
- Suzuki DOT 4 Brake Fluid
- Suzuki Silicone Grease, P/N 99000-25100S
- Suzuki Super Grease, P/N 99000-25011

2. Precautions

WARNING

Materials such as gasoline and other chemicals can be toxic or flammable.

When working with toxic or flammable materials, make sure the area you work in is well ventilated, and away from sparks or flames.

NOTICE

**Dust or mud may contaminate disassembled parts.
Clean the motorcycle prior to this replacement.**

NOTE:

When removing the battery, disconnect the negative (-) cable first, and then the positive (+) cable.

NOTE:

Refer to the appropriate Service Manual for additional service information or specifications.

3. Removing the front brake master cylinder, reservoir tank and front brake hose No. 1.

NOTICE

**Spilled brake fluid can damage painted surfaces and plastic parts.
Be careful not to spill any fluid when filling the brake fluid reservoir. Wipe up spilled fluid and wash stained parts with water immediately.**

- 1) Remove the bolts (1) and the front seat (2).

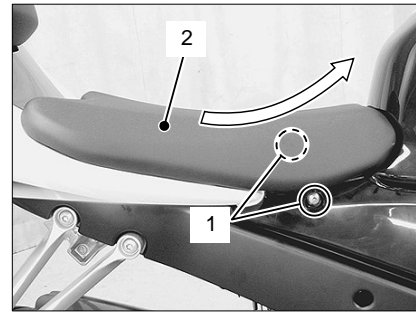

- 2) Remove the battery (-) lead wire (3).

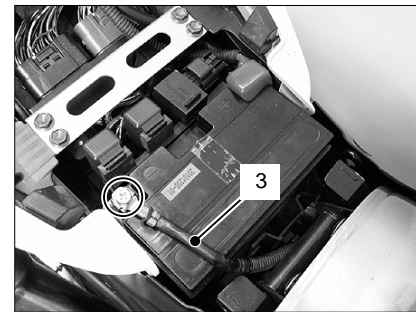

- 3) Cover the front right caliper with a shop rag to protect them from spilled brake fluid.

- 4) Remove brake hose union bolt (4), front brake hoses No. 2 (5) and No.1 (6) from the caliper.

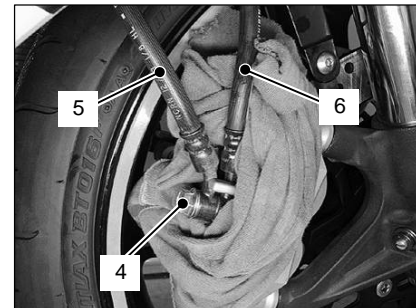

NOTE:

Bag the brake hoses separately to catch spilled brake fluid, and tie them off securely at the top.



- 5) Remove front brake No.1 hose (6) from the clamp (7).

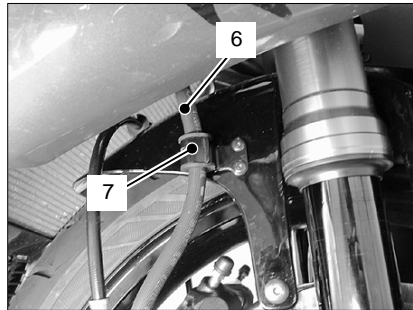

- 6) Remove the brake hose clamp bolt (8).

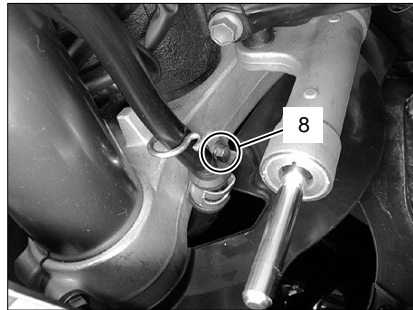

- 7) Disconnect the brake light switch lead wire couplers (9).

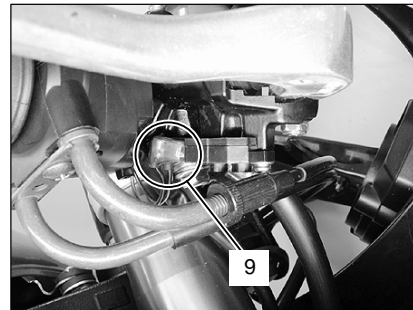

- 8) Remove the reservoir tank bracket bolt (10) and front master cylinder holder bolts (11).

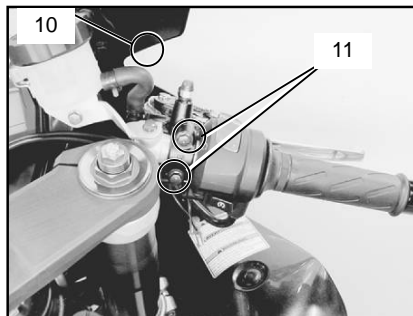

- 9) Lift up the front master cylinder, reservoir tank and front brake hose No.1.

NOTE:

Prevent the catch bag from coming off when pulling up on the brake hose.

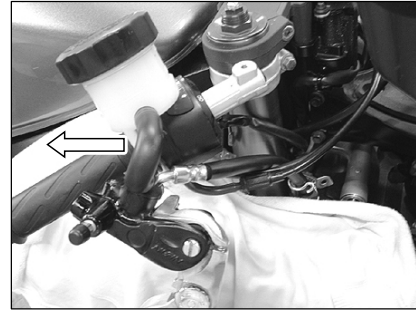

- 10) Remove the brake light switch (12) and brake lever (13).
11) Remove the brake hose union bolt (14).

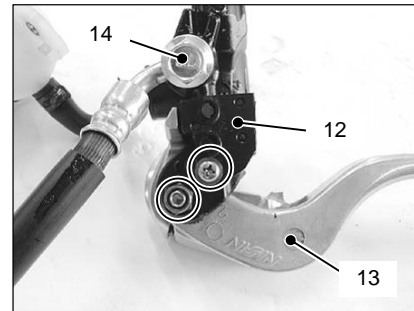

- 12) Remove the clamp (15) from the front brake hose No.1 (6).

NOTE:

Be careful not to damage the guide (A).

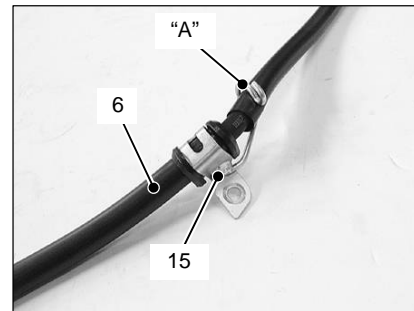

4. Assembling the front brake master cylinder, reservoir tank and front brake hose No.1

Front Master Cylinder Components

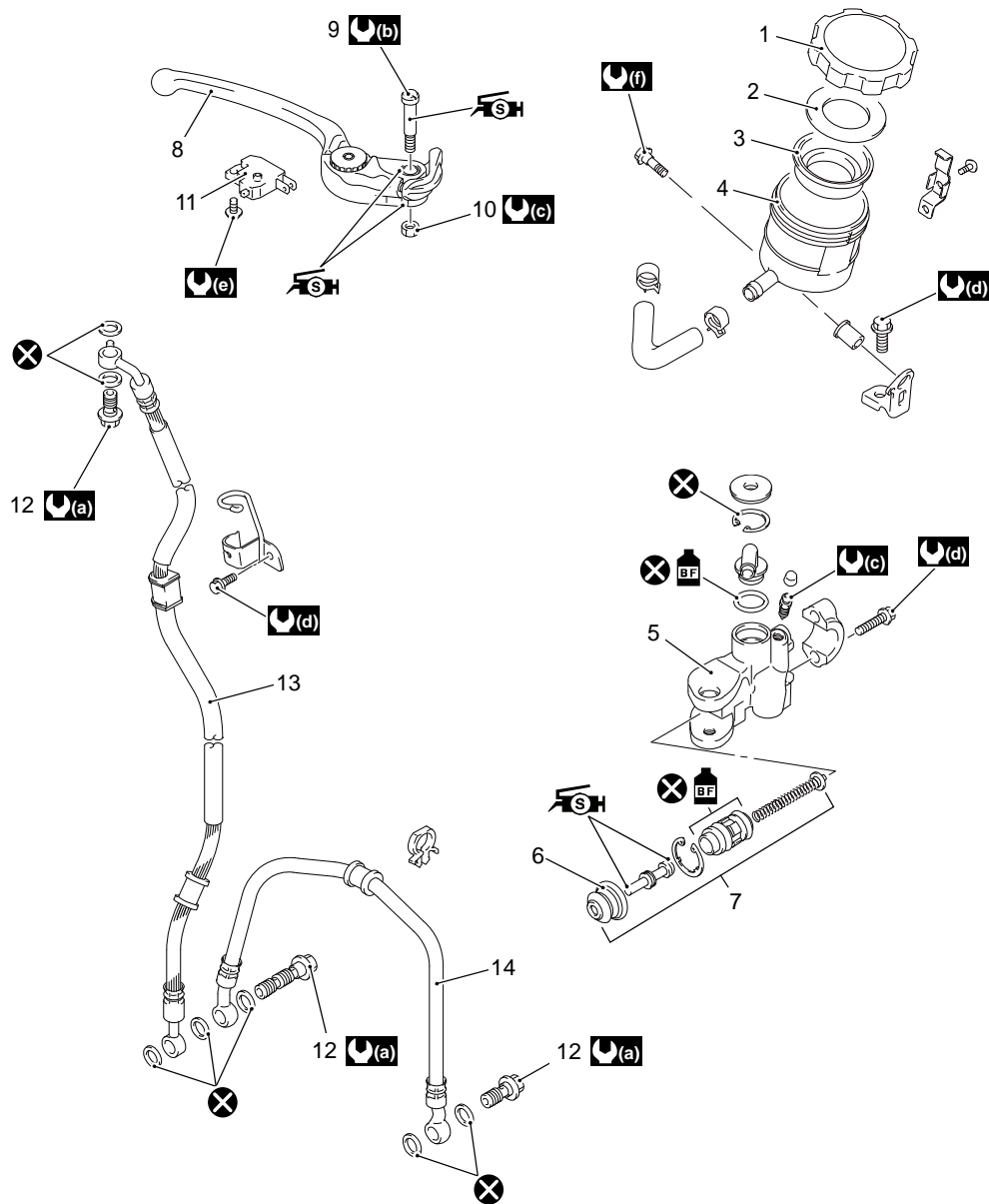

1.	Reservoir cap	9.	Brake lever pivot bolt	: (c)	6 N-m (0.6 kgf-m, 4.5 lbf-ft)
2.	Plate	10.	Brake lever pivot bolt lock-nut	: (d)	10 N-m (1.0 kgf-m, 7.0 lbf-ft)
3.	Diaphragm	11.	Brake light switch	: (e)	1.2 N-m (0.12 kgf-m, 1.0 lbf-ft)
4.	Reservoir tank	12.	Brake hose union bolt	: (f)	0.6 N-m (0.06 kgf-m, 0.6 lbf-ft)
5.	Front master cylinder	13.	Brake No.1 hose	: BF	Apply brake fluid.
6.	Dust boot	14.	Brake No.2 hose	: SH	Apply silicone grease.
7.	Piston set			: (a)	23 N-m (2.3 kgf-m, 16.5 lbf-ft)
8.	Brake lever			: (b)	1 N-m (0.1 kgf-m, 0.5 lbf-ft)
				: X	Do not reuse.

Front Master Cylinder

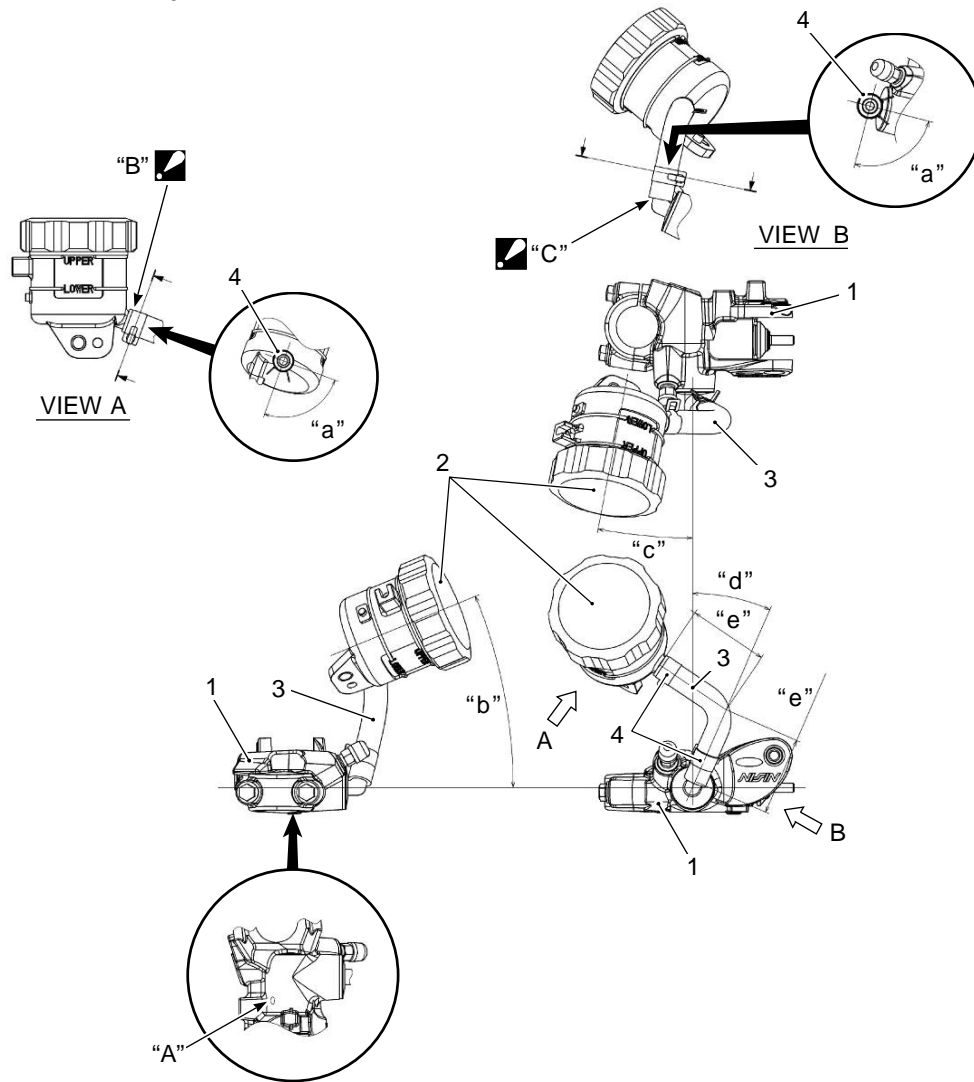

1.	Front master cylinder	"A":	Green paint	"b":	22°
2.	Reservoir tank	"B":	Insert hose until shoulder of reservoir tank	"c":	11°
3.	Reservoir tank hose	"C":	Insert hose until round shape	"d":	23.5°
4.	Clamp	"a":	90°	"e":	42.5mm

NOTE:

The master cylinder is has a green dot (A) in the position shown.

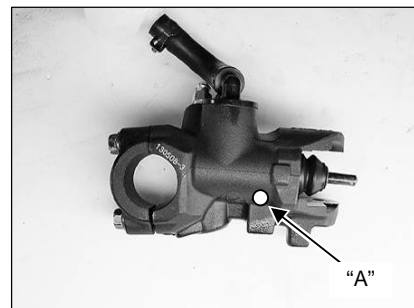

Front Brake Hose Routing Diagram

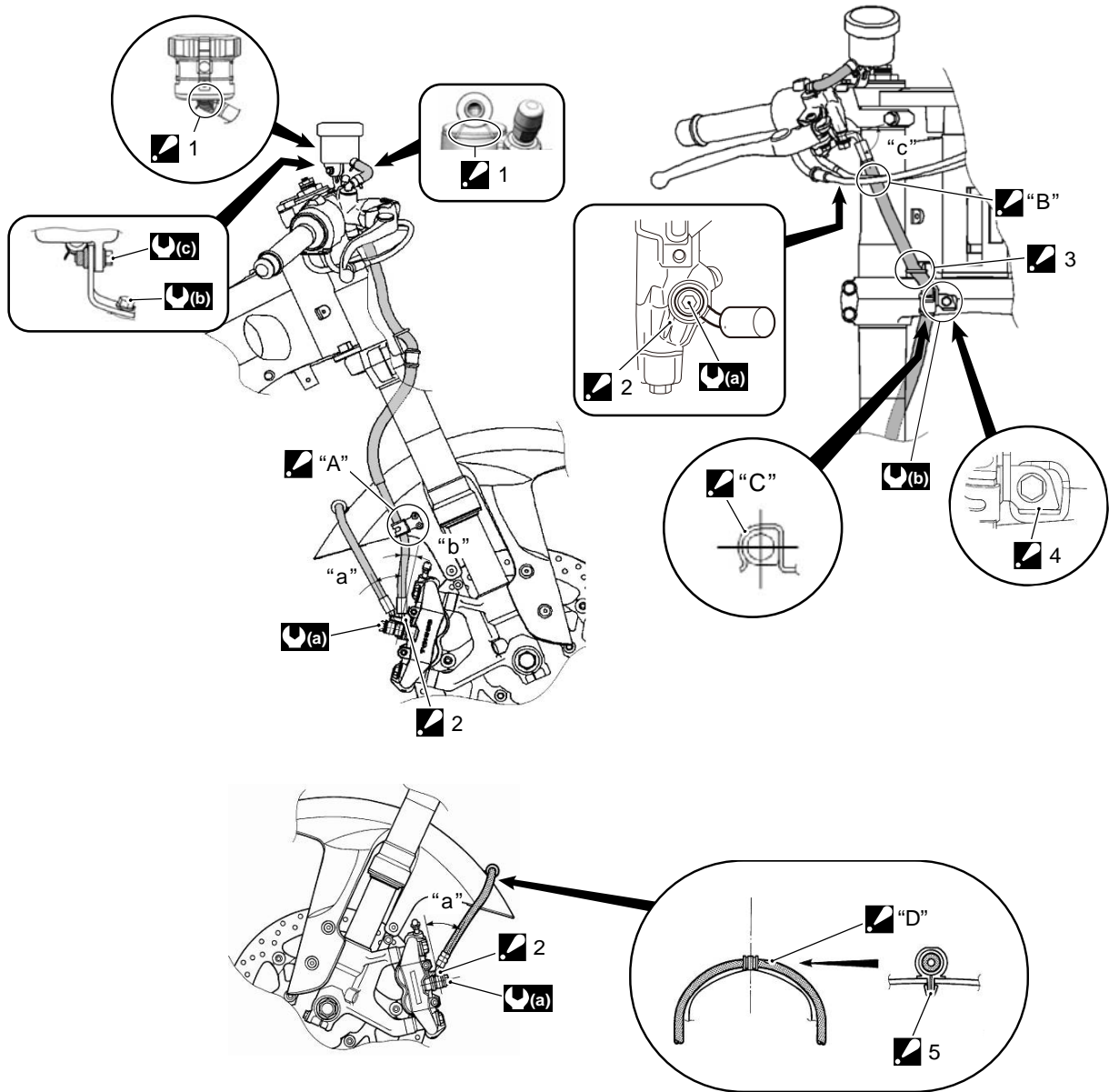

1	Clamp : Clamp end should face downward.	Clamp the brake hose firmly.	(b) 10 N·m (1.0 kgf-m, 7.0 lbf-ft)
2	Stopper : After the brake hose union has contacted to the stopper, tighten the union bolt.	Pass the brake hose behind throttle cables.	(c) 0.6 N·m (0.06 kgf-m, 0.6 lbf-ft)
3	Guide : Pass the brake hose into the guide.	Align the sleeve part of brake hose to clamp shape then firmly.	"a": 42°
4	Stopper : After positioning the clamp with the stopper, tighten the clamp bolt.	The green paint is right side and face upside.	"b": 14°
5	Clamp : Insert the clamp end into the hole on the front fender.	(a) 23 N·m (2.3 kgf-m, 16.5 lbf-ft)	"c": 49°

- 1) Apply silicone grease to brake contact surface of lever and push rod "B".

Suzuki Silicone Grease, P/N 99000-25100

- 2) Insert push rod "B" put into the hole when installing the brake lever (1) on the new master cylinder (2).

- 3) Apply silicone grease to brake lever pivot bolt(3).

Suzuki Silicone Grease, P/N 99000-25100

- 4) Tighten the brake lever pivot bolt (3) and the new lock-nut (4) to the specified torque.

Tightening torque:

Brake lever pivot bolt: 1 N·m (0.1 kgf-m, 0.5 lbf-ft)

Brake lever pivot bolt lock-nut: 6 N·m (0.6 kgf-m, 4.5 lbf-ft)

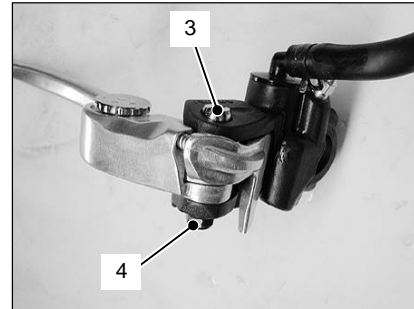
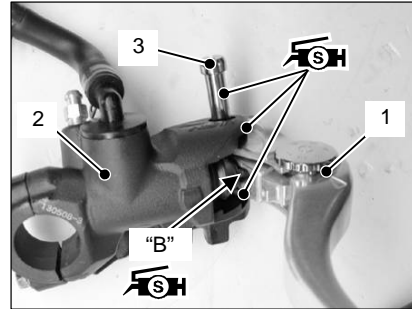

- 5) Install the brake light switch positioning tab (5) into the front master cylinder. Tighten screw to the specified torque.

Tightening torque:

Brake light switch screw: 1.2 N·m (0.12 kgf-m, 1.0 lbf-ft)

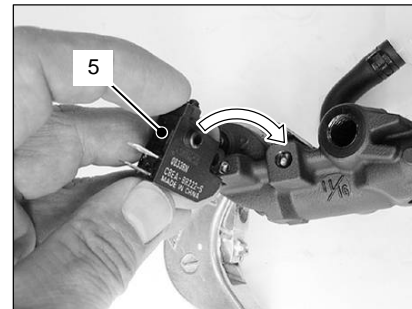

- 6) Align "C" and punch mark "D" (6) when assembling the new master cylinder(2) to the handlebar (6).

Tighten the upper bolt (7) first, then tighten lower bolt (8).

Check the clearance. Tighten the master cylinder bolts to the specified torque.

NOTE:

Make sure the UP mark is facing up.

Tightening torque:

Master cylinder holder bolt: 10 N·m (1.0 kgf-m, 7.0 lbf-ft)

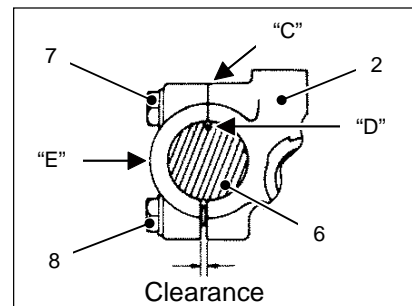
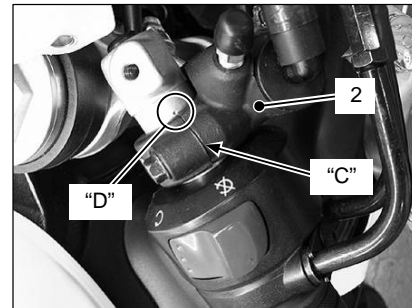

- 7) Tighten the new bolt (10) of of the new reservoir tank bracket (9) to the specified torque.

Tightening torque:

Reservoir tank bracket bolt: 10 N·m (1.0 kgf·m, 7.0 lbf·ft)

- 8) Install the new nut (11) to new reservoir tank bracket (9).

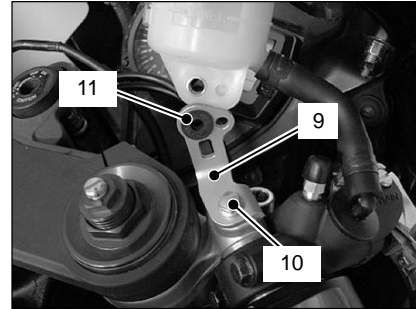

- 9) Align the locating tab of the new reservoir tank and the hole of new reservoir tank bracket (F).

- 10) Tighten the new reservoir tank bolt (12) to the specified torque.

Tightening torque:

Reservoir tank bolt: 0.6 N·m (0.06 kgf·m, 0.4 lbf·ft)

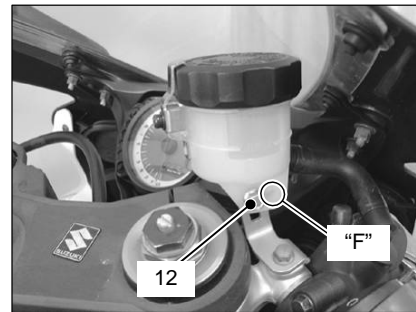

- 11) Insert the sleeve of the new brake hose No.1 (14) into the clamp (15) and secure the clamp (15). Then pass it through guide "G".

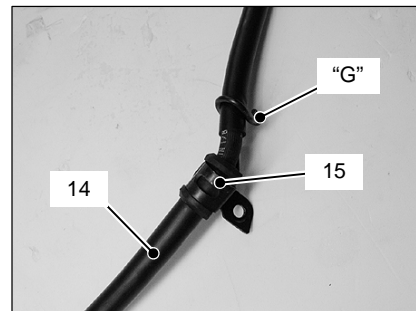

- 12) Route the front brake hose (13) as shown. After positioning the clamp (14) with the steering lower bracket stopper, tighten the clamp bolt (15).

Tightening torque

Bolt: 10 N·m (1.0 kgf·m, 7.0 lbf·ft)

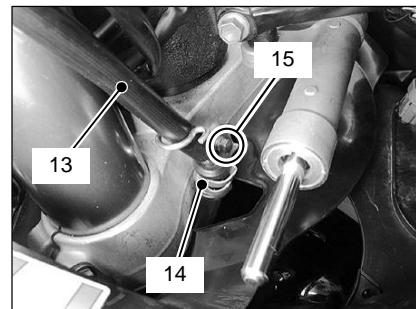

- 13) Clamp the sleeve part of new front brake hose (13) to clamp "H".

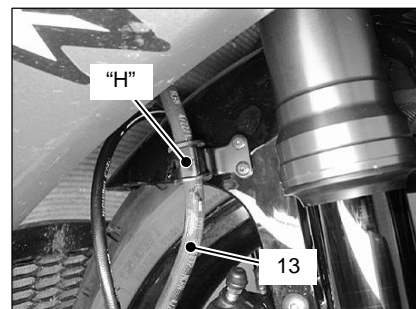

14) Install the three new sealing washers (16).

NOTE:

Clean the contact surfaces of the sealing washers (16) and the brake hose union bolt (17).

15) After positioning the brake hose union with the caliper stopper "I", tighten the union bolt (17) to the specified torque.

Tightening torque:

Brake hose union bolt: 23 N·m (2.3 kgf-m, 16.5 lbf-ft)

16) Route brake hose No.1 behind the throttle cable.

17) Install the new two sealing washers (18).

NOTE:

Clean the contact surface of the sealing washers (18) and the brake hose union bolt (19).

18) After positioning the brake hose union with the master cylinder stopper, tighten the union bolt (19) to the specified torque.

Tightening torque:

Brake hose union bolt: 23 N·m (2.3 kgf-m, 16.5 lbf-ft)

19) Connect the brake light switch lead wire couplers (20) securely.

20) Connect the battery (-) lead wire (21) securely.

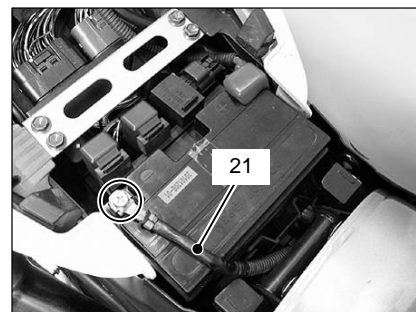
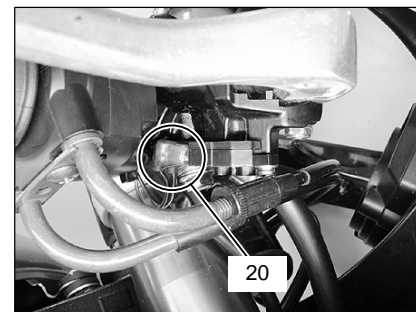
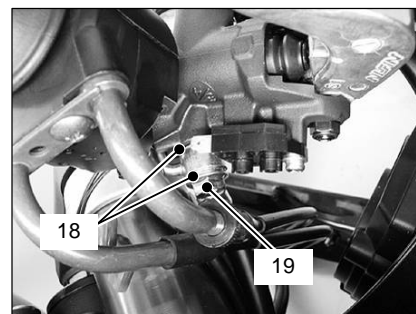
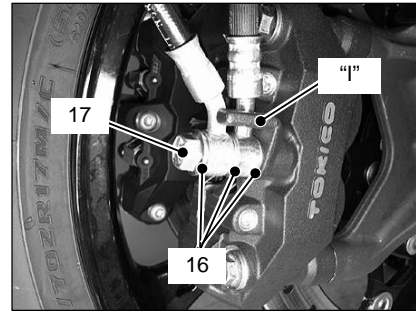

- 21) Slide the front seat hooks into the seat hook retainers on the frame and tighten the bolts to the specified torque.

Tightening torque:

Front seat bolt: 6 N·m (0.6 kgf·m, 4.5 lbf·ft)

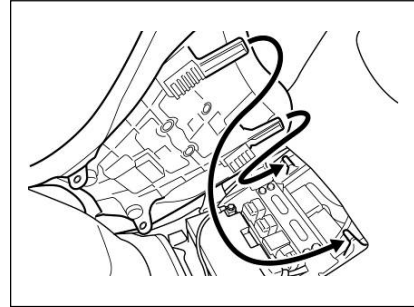

5. Front brake air bleeding

Air trapped in the brake fluid circuit acts like a cushion to absorb a large proportion of the pressure developed by the front master cylinder and thus interferes with the full braking performance of the brake caliper. The presence of air is indicated by “sponginess” of the brake lever and also by lack of braking force. It is essential that after remounting the brake and restoring the brake system to the normal condition, the brake fluid circuit be purged of air in the following manner:

NOTICE

Spilled brake fluid can damage painted surfaces and plastic parts.

Be careful not to spill any fluid when filling the brake fluid reservoir. Wipe up spilled fluid and wash stained parts with water immediately.

- 1) Place the motorcycle on a level surface and adjust the horizontal upper face of reservoir tank.
- 2) Remove the reservoir cap (2) and diaphragm.
- 3) Fill the master cylinder reservoir to the upper line “J”.

Specification and classification:

Suzuki DOT 4 Brake Fluid

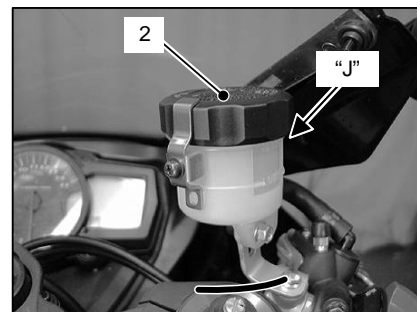

NOTE

- While bleeding the brake system, replenish the brake fluid in the reservoir as necessary.
- Make sure that there is always some fluid visible in the reservoir.
- Slowly pour due to prevent the bubble.
- Do not release brake lever when opening the air bleeder valve.



4) Pinch the reservoir hose by finger due to air release.

5) Attach a clear hose (1) to the master cylinder air bleeder valve, and insert the free end of the hose into a receptacle.

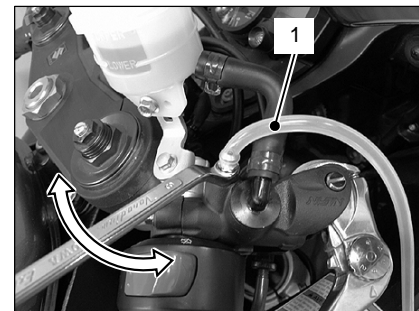

6) Squeeze and release the brake lever several times in rapid succession and squeeze and hold the lever fully without releasing it. Loosen the air bleeder valve by turning it 1/6 of a turn, then tighten it. Repeat this process until the fluid flowing into the clear hose no longer contains air bubbles.

7) Remove the clear hose (1).



8) Attach a clear hose (1) to the left side brake caliper air bleeder valve, and insert the free end of the hose into a receptacle.

9) Squeeze and release the brake lever several times in rapid succession then squeeze and hold the lever fully without releasing it. Loosen the air bleeder valve by turning it a 1/6 of a turn then tighten it. Repeat this process until fluid is flowing into the clear hose.

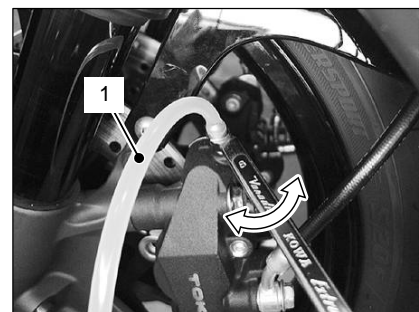

- 10) Repeat this process five times until the fluid flowing into the receptacle no longer contains air bubbles.
- 13) Remove the clear hose (1).
- 14) Bleed the right side brake caliper using the same air bleeding procedure.
- 15) Confirm brake lever feel after bleeding the system. If the lever does not feel firm, repeat the air bleeding procedure.

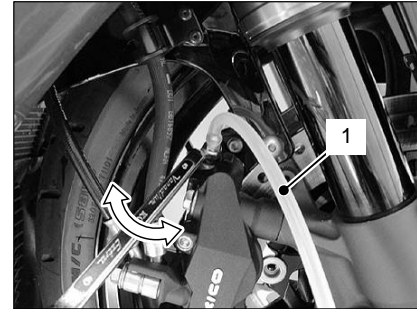

NOTE:

Only use fresh Suzuki DOT 4 Brake Fluid.

- 16) Tighten the brake caliper and master cylinder air bleeder valve to the specified torque.

Tightening torque:

Brake caliper air bleeder valve: 7.5 N·m
(0.75 kgf·m, 5.5 lbf·ft)

Master cylinder air bleeder valve: 6 N·m
(0.6 kgf·m, 4.5 lbf·ft)

- 17) Fill the master cylinder reservoir to the upper line "J".

- 18) Install the diaphragm, reservoir cap (2) and the plate (3) with a screw.

Specification and classification:

Suzuki DOT 4 Brake Fluid

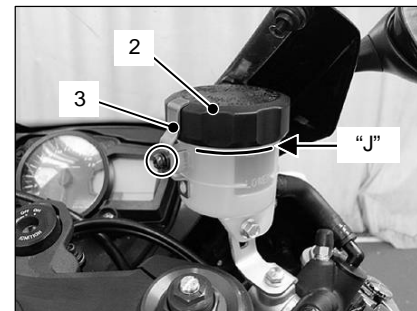

6. Inspection and confirmation after air bleeding

- Check each part's condition and torque.
- Check the brake lever for smooth operation.
- Check the unit's braking performance.
- Adjust the clock.
- Make sure the lights, brake light and turn signals, and all electrical components function properly.
- Make sure the throttle grip returns smoothly and automatically.
- After the procedure is complete, check that handlebar movement does not raise the engine idle speed.
- For any additional procedures or specifications, refer to the Service Manual.