

## Parts Kit E, P/N 59000-01850-RX0 2008-2010 GSX-R600/750 Front Master Cylinder Installation Guide

### 1. Preparation

#### REPLACEMENT PARTS

Part Name	Qty	Description
Cylinder kit, FR MASTER	1	Master cylinder set, P/N 59601-47H10 x1 Bracket, reservoir tank, P/N 59751-37H00 x1 Washer, brake hose, P/N 09161-10009 x2 Bolt, reservoir tank, P/N 09111-05006 x1 Nut, reservoir tank, P/N 09159-05048 x1 Nut, brake lever, P/N 57433-09F00 x1

#### TOOLS AND LUBRICANTS NEEDED:

- Screwdriver (Phillips No. 2 & flat blade No. 3)
- Hexagon socket wrench (4mm)
- Socket wrenches (8, 10, 12mm)
- Wrenches (8, 10, 12mm)
- Ratchet, extension bar for ratchet, torque wrench
- Parts cleaner, clear hose, receptacle
- Suzuki DOT 4 Brake Fluid
- Suzuki Silicone Grease, P/N 99000-25100,
- Suzuki Super Grease, P/N 99000-25011

### 2. Precautions

#### **WARNING**

**Materials such as gasoline and other chemicals can be toxic or flammable.**

**When working with toxic or flammable materials, make sure the area you work in is well ventilated, and away from sparks or flames.**

#### **NOTICE**

**Dust or mud may contaminate disassembled parts.  
Clean the motorcycle prior to this replacement.**

#### *NOTE:*

*When removing the battery, disconnect the negative (-) cable first, and then the positive (+) cable.*

#### *NOTE:*

*Refer to the appropriate Service Manual for additional service information or specifications.*

### 3. Removing the front brake master cylinder and reservoir tank

**NOTICE**

Spilled brake fluid can damage painted surfaces and plastic parts.  
Be careful not to spill any fluid when filling the brake fluid reservoir. Wipe up spilled fluid and wash stained parts with water immediately.

- 1) Remove the bolts (1) and Front seat (2).

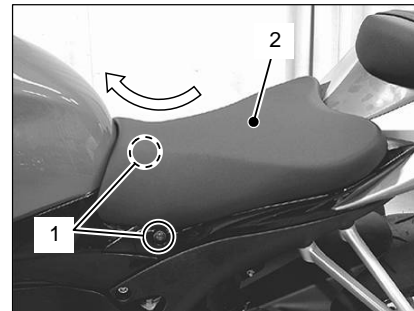

- 2) Remove the battery (-) lead wire (3).

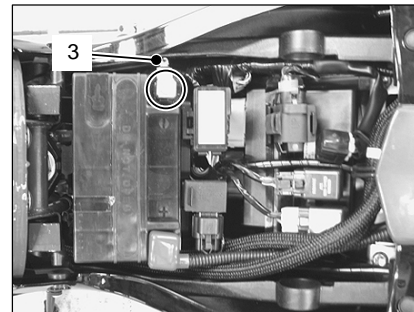

- 3) Disconnect the brake light switch lead wire coupler (4).

- 4) Place a rag under the brake hose union bolt (5) to catch any spilled brake fluid.

- 5) Remove the brake hose union bolt (5).

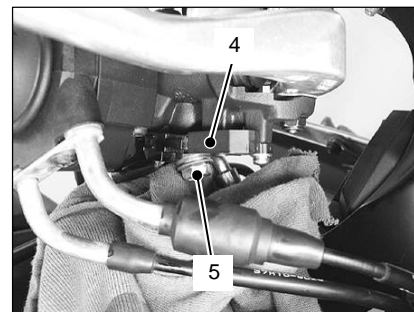

**NOTE:**

*Remove the the cap (6) from the new master cylinder and install it on the removed master cylinder to prevent spilled brake fluid.*

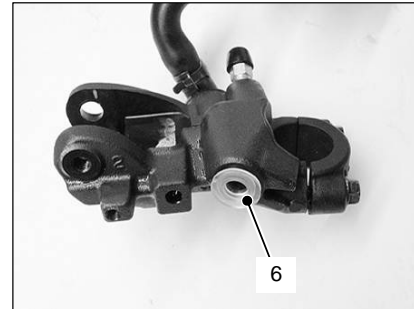

6) Remove the reservoir tank bracket bolt (7) and front master cylinder holder bolts (8).

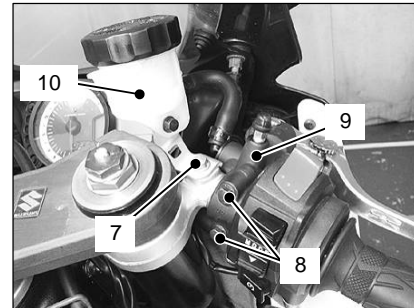

7) Remove front master cylinder (9) together with the reservoir tank (10).

8) Remove the brake light switch (11) and brake lever (12).

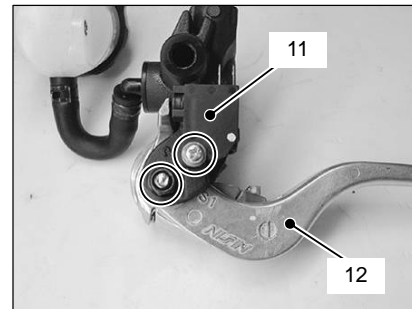

## 4. Reassembling the front master cylinder and reservoir tank

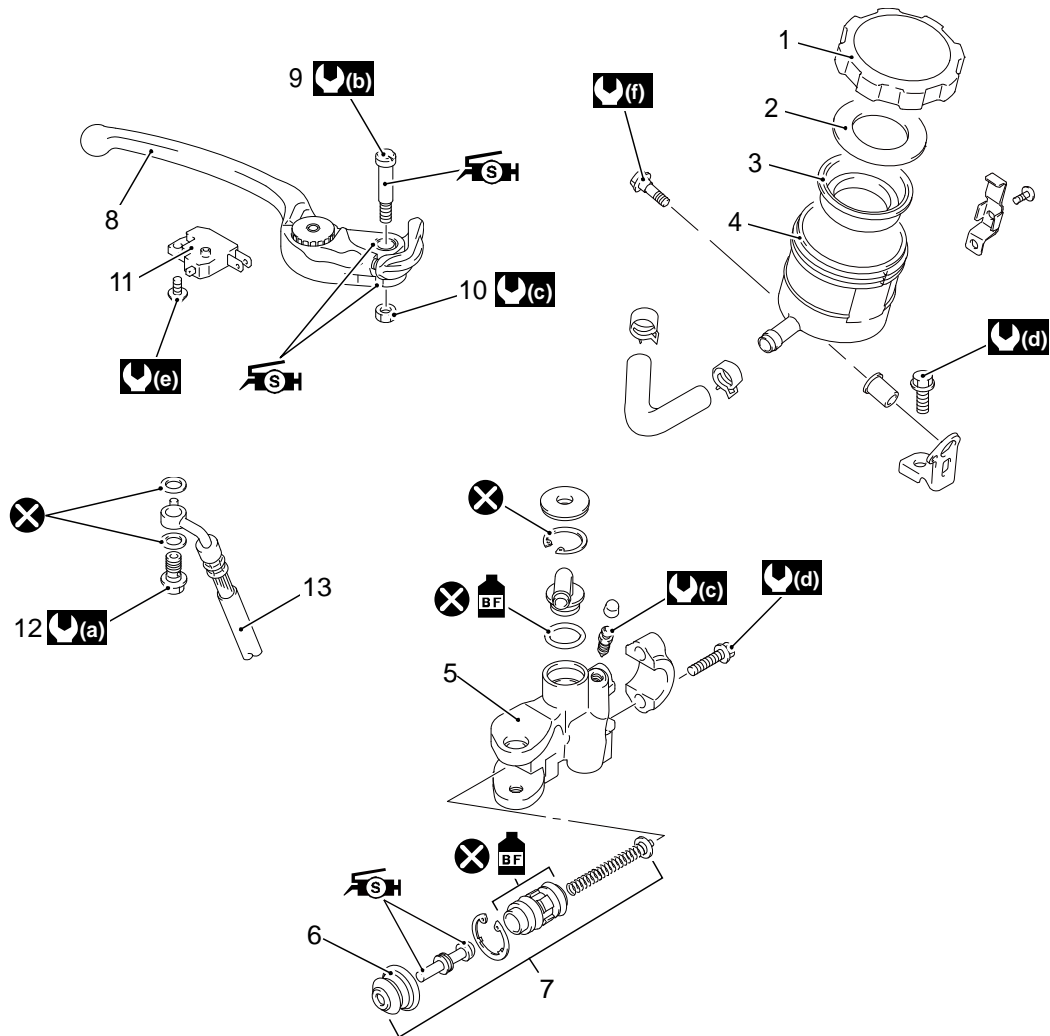

### Front Master Cylinder Components

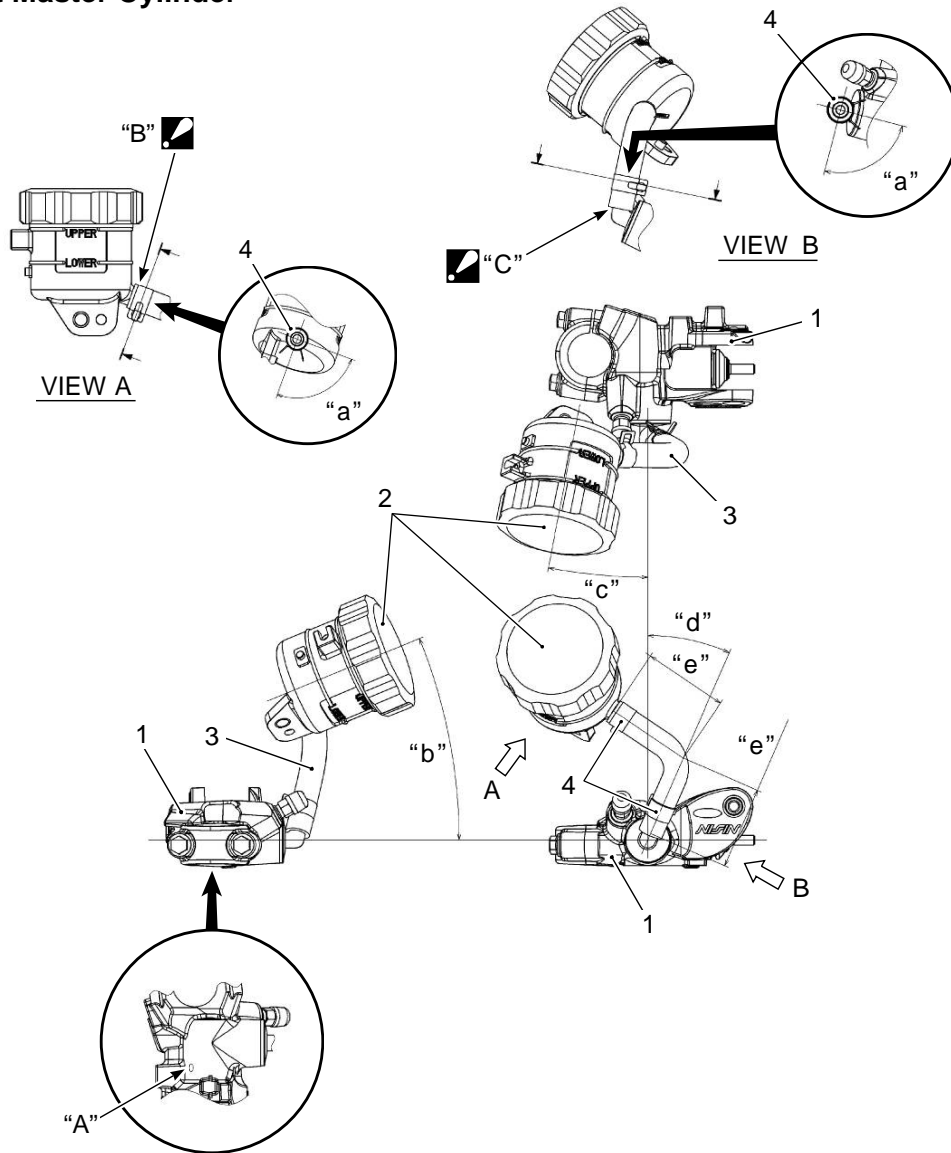

1.	Reservoir cap	9.	Brake lever pivot bolt	:  (d)	10 N·m (1.0 kgf·m, 7.0 lbf·ft)
2.	Plate	10.	Brake lever pivot bolt lock-nut	:  (e)	1.2 N·m (0.12 kgf·m, 1.0 lbf·ft)
3.	Diaphragm	11.	Brake light switch	:  (f)	0.6 N·m (0.06 kgf·m, 0.4 lbf·ft)
4.	Reservoir tank	12.	Brake hose union bolt	:  (BF)	Apply brake fluid.
5.	Master cylinder	13.	Brake hose	:  (S)	Apply silicone grease.
6.	Dust boot			:  (a)	23 N·m (2.3 kgf·m, 16.5 lbf·ft)
7.	Piston set			:  (b)	1 N·m (0.1 kgf·m, 0.5 lbf·ft)
8.	Brake lever			:  (c)	6 N·m (0.6 kgf·m, 4.5 lbf·ft)

# Front Master Cylinder



1. Master cylinder	"A": Blue paint	"b": 22°
2. Reservoir tank	"B"  Insert hose until shoulder of reservoir tank	"c": 11°
3. Reservoir tank hose	"C"  Insert hose until round shape	"d": 23.5°
4. Clamp	"a": 90°	"e": 42.5mm

**NOTE:**

The new master cylinder has a blue dot (A) in the position shown.

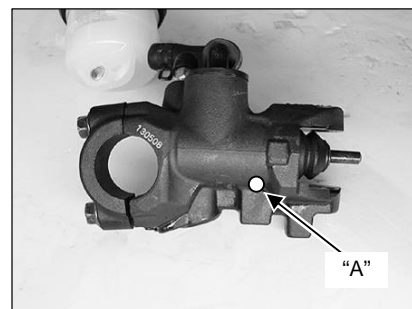

## Front Brake Hose Routing Diagram

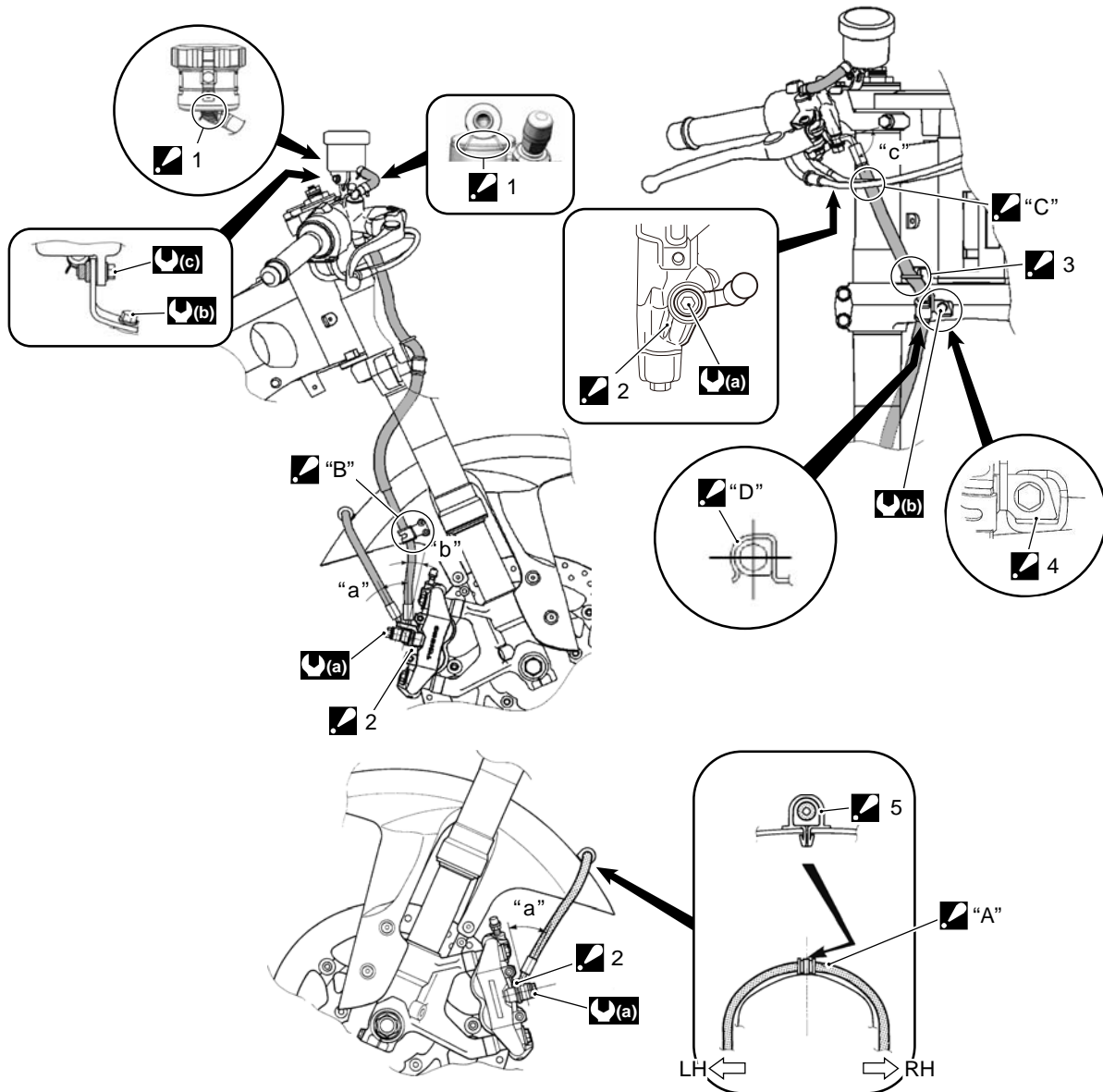

1	Clamp : Clamp end should face downward.	White marking : White marking should be on right side and face upward.	10 N·m (1.0 kgf-m, 7.0 lbf-ft)
2	Stopper : After the brake hose union has contacted to the stopper, tighten the union bolt.	Clamp the brake hose firmly.	0.6 N·m (0.06 kgf-m, 0.4 lbf-ft)
3	Guide : Pass the brake hose into the guide.	Pass the brake hose behind throttle cables.	"a": 40°
4	Stopper : After positioning the clamp with the stopper, tighten the clamp bolt.	Align the sleeve part of brake hose to clamp shape then set firmly.	"b": 15°
5	Hose clamp : Insert the clamp end into the hole on the front fender.	23 N·m (2.3 kgf-m, 16.5 lbf-ft)	"c": 77°

- 1) Apply silicone grease to the contact surface of the brake lever (1) and push rod "B".

Suzuki Silicone Grease, P/N 99000-25100

- 2) Insert push rod "B" into the hole when installing the brake lever (1) on the new master cylinder (2).

- 3) Apply silicone grease to brake lever pivot bolt (3).

Suzuki Silicone Grease, P/N 99000-25100

- 4) Tighten the brake lever pivot bolt (3) and new lock-nut (4) to the specified torque.

Tightening torque:

Brake lever pivot bolt: 1 N·m (0.1 kgf-m, 0.5 lbf-ft)

Brake lever pivot bolt lock-nut: 6 N·m (0.6 kgf-m, 4.5 lbf-ft)

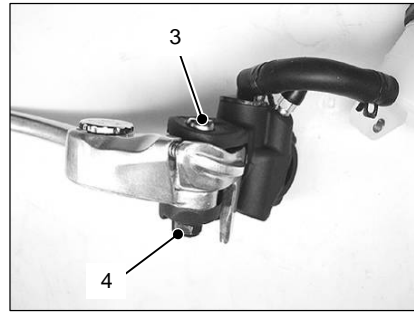
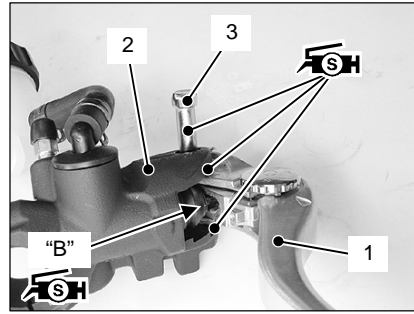

- 5) Install the brake light switch positioning tab (5) into the front brake master cylinder. Tighten the screw to the specified torque.

Tightening torque:

Brake light switch screw: 1.2 N·m (0.12 kgf-m, 1.0 lbf-ft)

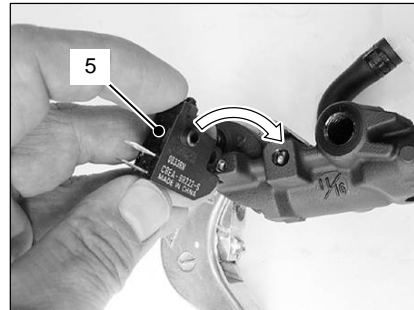

- 6) Align "C" and punch mark "D" (6) when assembling the new master cylinder (2) to the handlebar (6). Tighten the upper bolt (7) first, then tighten the lower bolt (8). Check the clearance, and tighten the new master cylinder bolts to the specified torque.

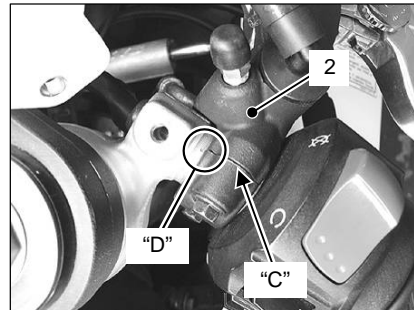

**NOTE:**

*Make sure the UP mark (E) is facing up.*

Tightening torque:

Master cylinder holder bolt: 10 N·m (1.0 kgf-m, 7.0 lbf-ft)

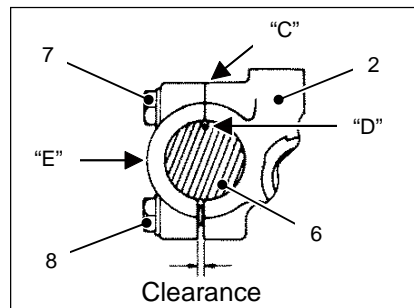

7) Install the new reservoir tank bracket (9).

8) Tighten the new reservoir tank bracket bolt (10) to the specified torque.

Tightening torque:

Reservoir tank bracket bolt: 10 N·m (1.0 kgf·m, 7.0 lbf·ft)

9) Install the new nut (11) to the reservoir tank bracket (9).

10) Align the reservoir tank positioning tab and hole of the new reservoir tank bracket (F).

11) Tighten the new reservoir tank bolt (12) to the specified torque.

Tightening torque:

Reservoir tank bolt: 0.6 N·m (0.06 kgf·m, 0.4 lbf·ft)

12) Install new sealing washers (13).

**NOTE:**

*Clean the sealing washer (13) and brake hose union bolt (14) surfaces before assembling.*

13) Attach the brake hose union bolt to the stopper of the front master cylinder. Tighten the brake hose union bolt (14) to the specified torque.

Tightening torque:

Brake hose union bolt: 23 N·m (2.3 kgf·m, 16.5 lbf·ft)

14) Connect the brake light switch lead wire couplers (15) securely.

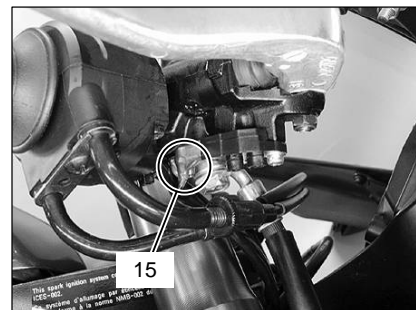
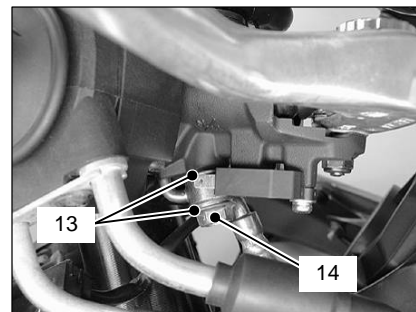
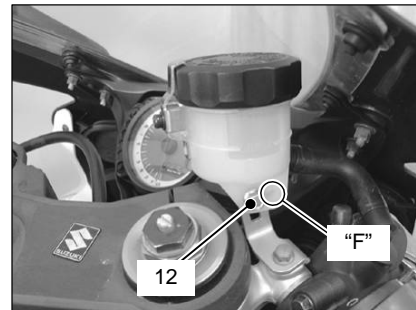
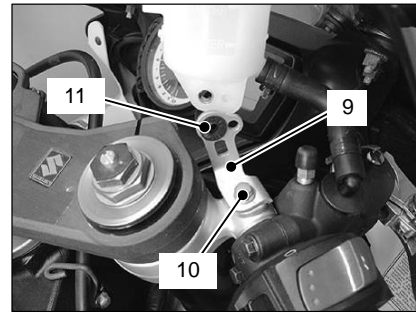

15) Connect the battery (-) lead wire (16) securely.

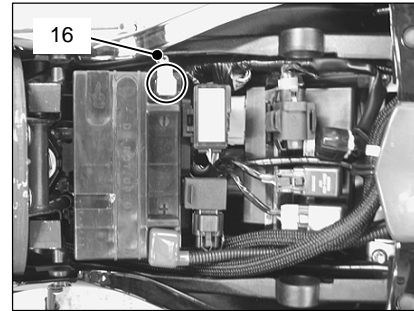

16) Slide the front seat hooks into the seat hook retainers on the frame and tighten the bolts to the specified torque.

Tightening torque:

Front seat bolt: 6 N·m (0.6 kgf-m, 4.5 lbf-ft)

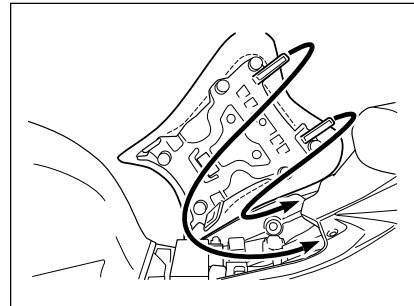

## 5. Front brake air bleeding

Air trapped in the brake fluid circuit acts like a cushion to absorb a large proportion of the pressure developed by the master cylinder and thus interferes with the full braking performance of the brake caliper. The presence of air is indicated by “spongy” of the brake lever and also by lack of braking force. It is essential that after remounting the brake and restoring the brake system to the normal condition, the brake fluid circuit be purged of air in the following manner:

### **NOTICE**

**Spilled brake fluid can damage painted surfaces and plastic parts.**

**Be careful not to spill any fluid when filling the brake fluid reservoir. Wipe up spilled fluid and wash stained parts with water immediately.**

- 1) Place the motorcycle on a level surface and adjust the horizontal upper face of the reservoir tank.
- 2) Remove the reservoir cap (2) and diaphragm.
- 3) Fill the master cylinder reservoir to the upper line "G".

Specification and classification:

Suzuki DOT 4 Brake Fluid

**NOTE:**

- *While bleeding the brake system, replenish the brake fluid in the reservoir as necessary.*
- *Make sure there is always some fluid visible in the reservoir.*
- *Slowly pour fluid to prevent air bubbles.*
- *Do not release the brake lever when opening the air bleeder valve.*

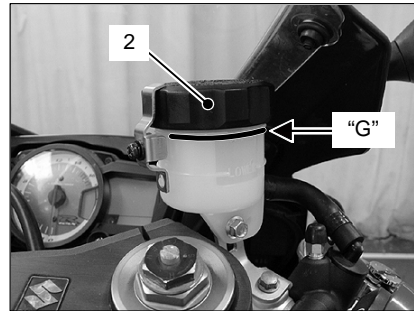

- 4) Pinch the reservoir hose by finger until all air in the hose has released.



- 5) Attach a clear hose (1) to the master cylinder air bleeder valve, and insert the free end of the hose into a receptacle.
- 6) Squeeze and release the brake lever several times in rapid succession and squeeze and hold the lever fully without releasing it. Loosen the air bleeder valve by turning it 1/6 of a turn, then tighten it. Repeat this process until the fluid flowing into the clear hose no longer contains air bubbles.
- 7) Remove the clear hose (1).

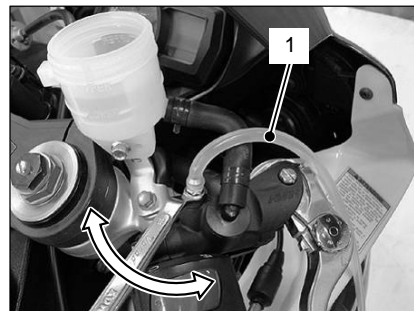

- 8) Attach a clear hose (1) to the left side brake caliper air bleeder valve, and insert the free end of the hose into a receptacle.

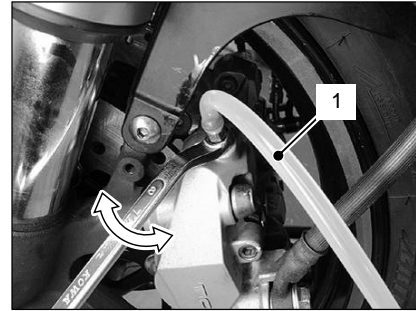

- 9) Squeeze and release the brake lever several times in rapid succession then squeeze and hold the lever fully without releasing it. Loosen the air bleeder valve by turning it a 1/6 of a turn, then tighten it. Repeat this process until fluid is flowing into the clear hose.

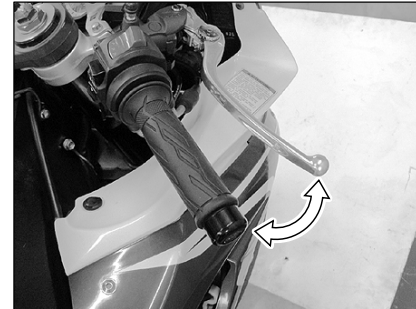

- 10) Repeat this process five times until the fluid flowing into the clear hose no longer contains air bubbles.

- 11) Remove the clear hose (1).

- 12) Bleed the right side brake caliper using the same air bleeding procedure.

- 13) Confirm brake lever feel after bleeding the system. If the lever does not feel firm, repeat the air bleeding procedure.

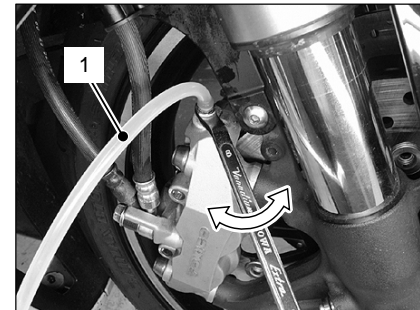

**NOTE:**

*Only use fresh Suzuki DOT 4 Brake Fluid.*

- 14) Tighten the brake caliper air bleeder valves to the specified torque.

Tightening torque:

Brake caliper air bleeder valve: 7.5 N·m  
(0.75 kgf-m, 5.5 lbf-ft)

- 15) Tighten the master cylinder air bleeder valve to the specified torque.

Tightening torque:

Master cylinder air bleeder valve: 6 N·m  
(0.6 kgf-m, 4.5 lbf-ft)

16) Fill the reservoir with brake fluid to the upper line “G” of the reservoir.

Specification and classification:

Suzuki DOT 4 Brake Fluid

17) Install the diaphragm and reservoir cap (2) and the bracket (3) with a screw.

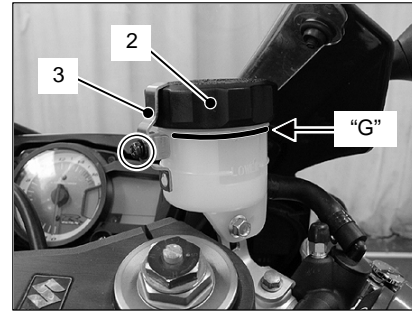

## 6. Inspection and confirmation after air bleeding

- Check each part's condition and torque.
- Check the brake lever for smooth operation.
- Check the unit's braking performance.
- Adjust the clock.
- Make sure the lights, brake light and turn signals, and all electrical components function properly.
- For any additional procedures or specifications, refer to the Service Manual.