



Applies To: **2003–04 Odyssey** – Check the iN VIN status for eligibility

October 24, 2013

Safety Recall: Electrical Noise May Cause Inadvertent Front Airbag Deployment

(Supersedes 13-088, *Safety Recall: Electrical Interference May Cause Inadvertent Front Airbag Deployment*, dated September 19, 2013; see REVISION SUMMARY)

REVISION SUMMARY

The information in this bulletin is complete and no longer preliminary.

BACKGROUND

Electrical noise (interference) generated by the vehicle may inadvertently cause the front airbags to deploy.

CUSTOMER NOTIFICATION

Owners of affected vehicles will be sent a notification of this campaign.

Do an **iN VIN status inquiry** to make sure the vehicle is shown as eligible.

Some vehicles affected by this campaign may be in your used vehicle inventory. These vehicles **must** be repaired before they are sold.

Should your dealership sell an unrepaired vehicle that subsequently causes injury or damage because of the recalled item, the dealership will be solely responsible to the damaged party, and will be required to defend and indemnify American Honda for any resulting claims. To see if a vehicle in inventory is affected by this recall, do a VIN status inquiry before selling it.

CORRECTIVE ACTION

Replace the SRS subharness with a new one that includes a noise suppressor.

PARTS INFORMATION

Noise Suppressor Kit (includes SRS subharness, noise suppressor, bracket, Torx bolts (4), bolt and nut):
P/N 06772-S0X-000

WARRANTY CLAIM INFORMATION

Operation Number: 7521G7

Flat Rate Time: 1.0 hour

Template ID: 13-088A

Failed Part: P/N 77960-S0X-L81

Defect Code: 5JN00

Symptom Code: JC200

Skill Level: Repair Technician

REPAIR PROCEDURE

NOTE:

- Before doing this repair procedure, review the SRS Precautions and Procedures (online, enter keyword **PRECAUTION**, and select **SRS Precautions and Procedures** from the list).
 - The SRS unit mounting bolts have a shallow Torx recess and can strip if the Torx driver is not fully engaged. Always make sure that the driver is fully seated in the recess before attempting to loosen or tighten a bolt. Also periodically check that your Torx bit is sharp and flat. If it is not, dress the end of your driver with a grinder.
1. Make sure you have the anti-theft codes for the audio and navigation system, then write down the frequencies for the radio channel presets.
 2. Start the engine, and check that the SRS indicator comes on and goes off after about 6 seconds.
 - If the SRS indicator does not go off, there is a DTC stored in the SRS unit. Write on the RO that the vehicle arrived at the dealership with the SRS indicator ON. Installing the SRS subharness will not repair any DTCs; it is the customer's responsibility to have the DTC diagnosed and repaired. Go to step 3.
 - If the SRS indicator turns off, go to step 3.
 3. Disconnect the negative battery cable, and wait at least 3 minutes before beginning work.



CUSTOMER INFORMATION: The information in this bulletin is intended for use only by skilled technicians who have the proper tools, equipment, and training to correctly and safely maintain your vehicle. These procedures should not be attempted by "do-it-yourselfers," and you should not assume this bulletin applies to your vehicle, or that your vehicle has the condition described. To determine whether this information applies, contact an authorized Honda automobile dealer.

4. Remove the center lower trim.

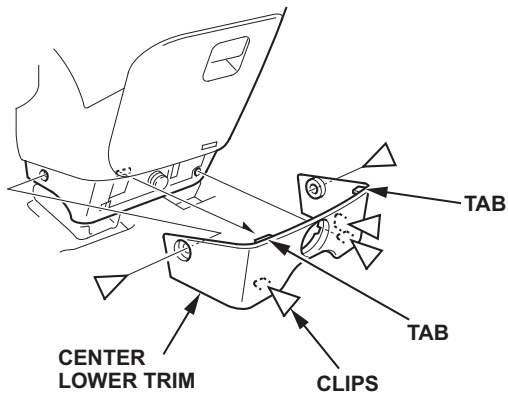

'03-'04 MODELS WITH NAVIGATION SYSTEM:

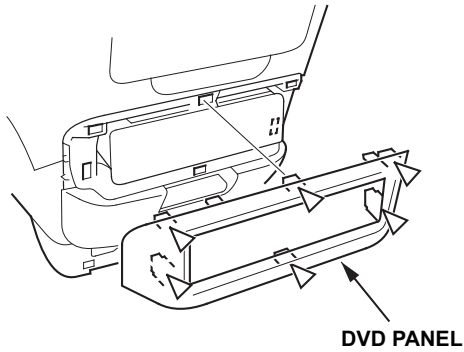

5. Remove the center lower pocket.

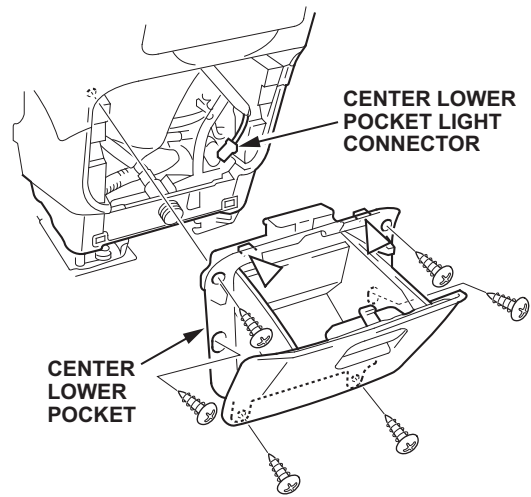

'03-'04 MODELS WITH NAVIGATION SYSTEM:

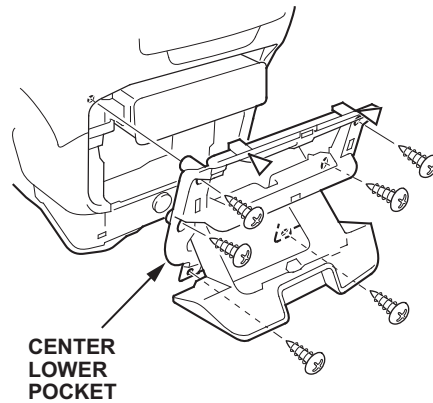

6. Remove the driver's and passenger's heater lower covers.

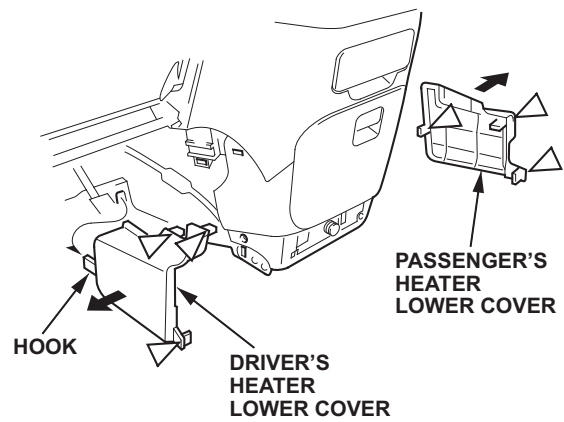

- Disconnect the two yellow connectors, and remove the clip from the floor.

DRIVER'S SIDE

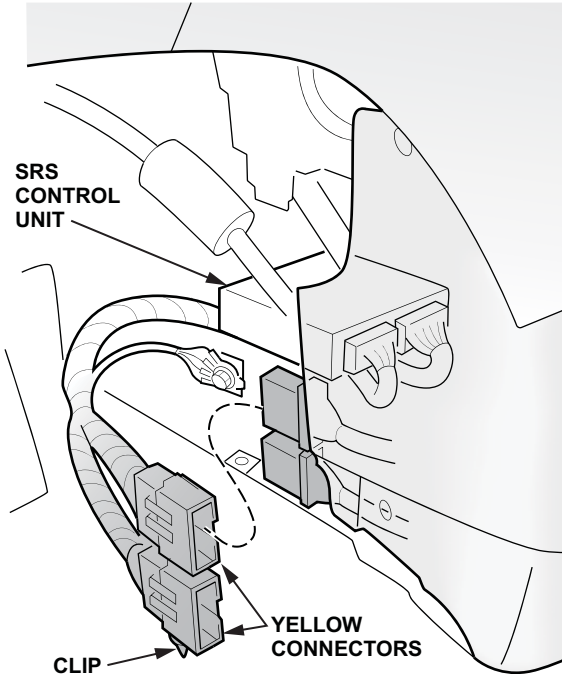

- Remove the three Torx bolts from the SRS unit.
NOTE: You may need to pull down the carpet on the passenger's side to access the Torx bolt.

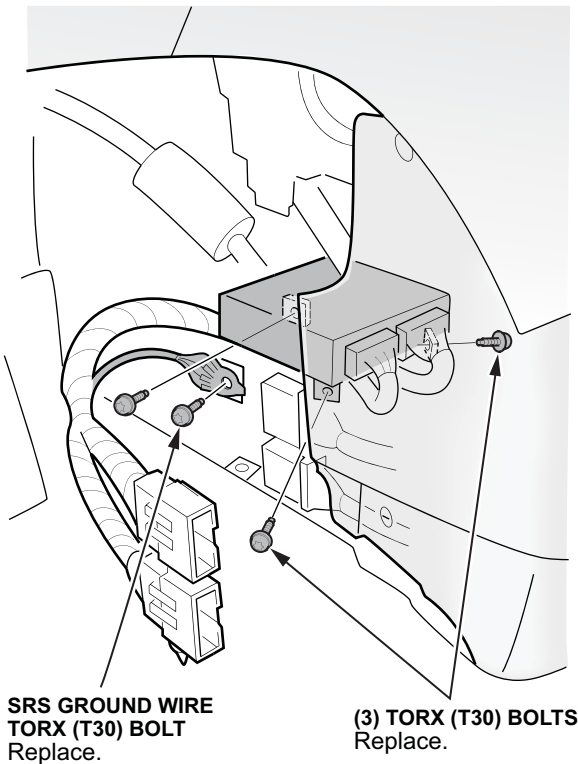

- Remove the SRS ground wire Torx (T30) bolt.

- Remove the SRS unit and the subharness from the vehicle.

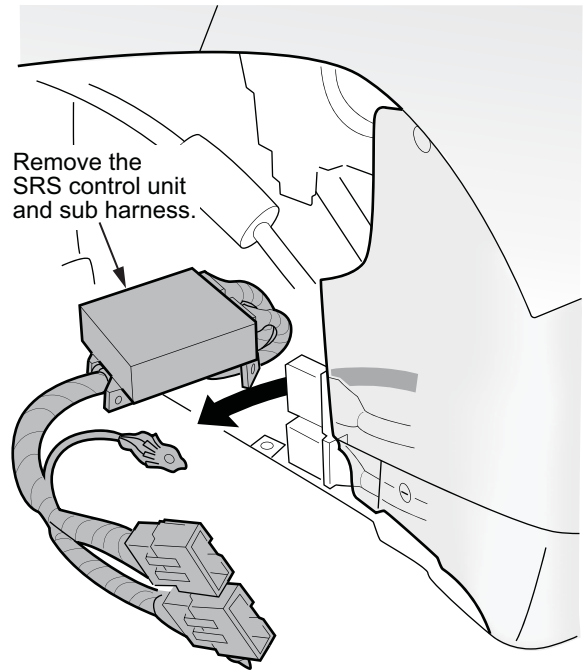

- Remove the subharness clip from the underside of the SRS unit, then disconnect the subharness from the unit.

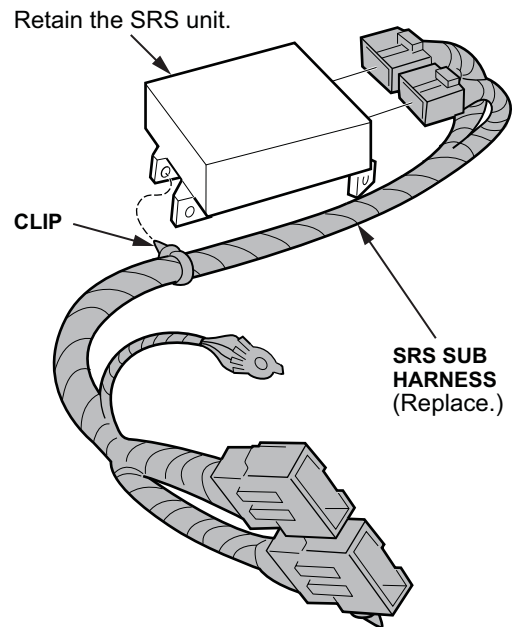

- Cut the connector off one end of the SRS subharness to make sure that it cannot be reused.

13. Install the new SRS subharness to the SRS unit, then install the subharness clip on the underside of the unit.

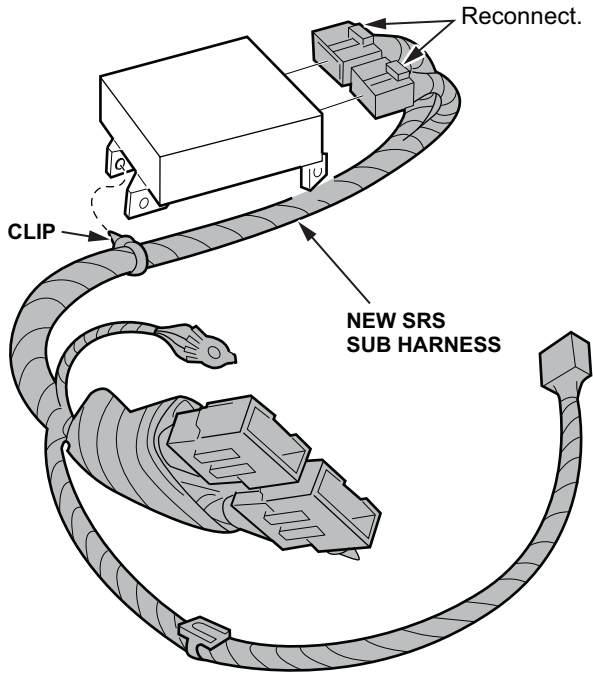

14. Reinstall the SRS unit and SRS subharness into the vehicle and install the three Torx bolts finger-tight.

NOTE: Make sure you are lightly pressing down on the SRS unit because the subharness can lift the unit.

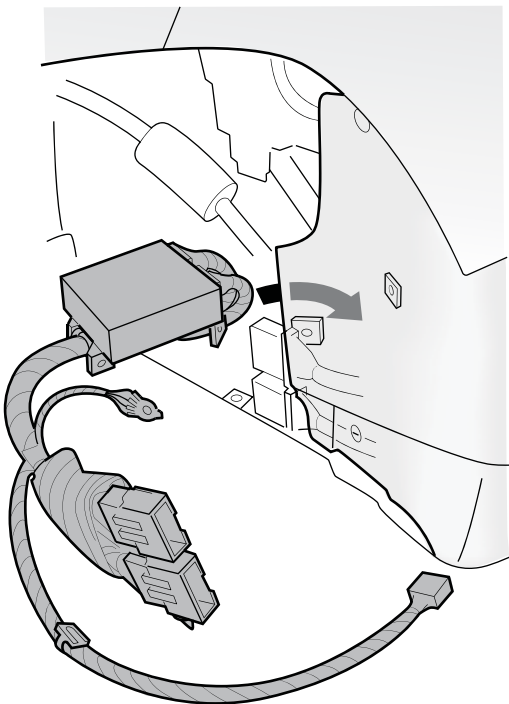

15. Torque the three Torx bolts to **9.8 N•m (7.2 lb-ft)**.

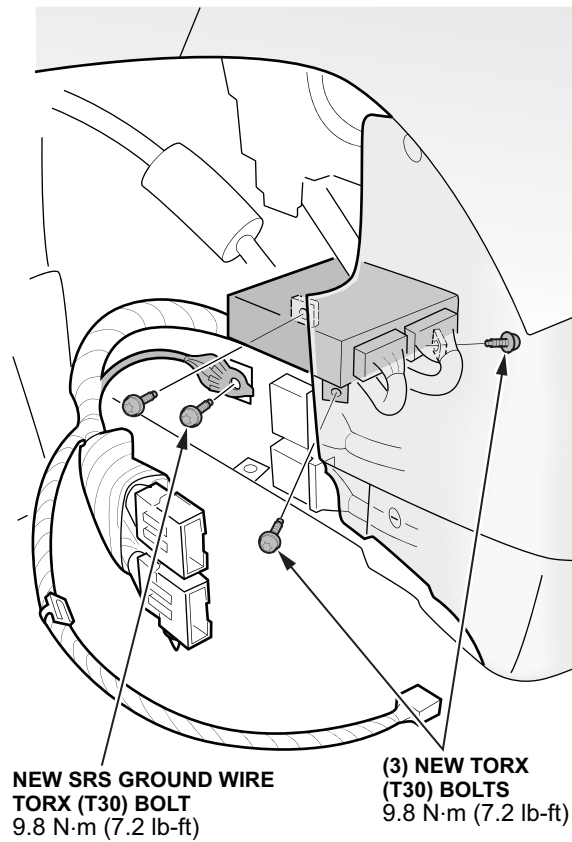

16. Install the fourth Torx bolt to secure the ground wire and torque it to **9.8 N•m (7.2 lb-ft)**.

17. Reconnect the connectors and the clip.

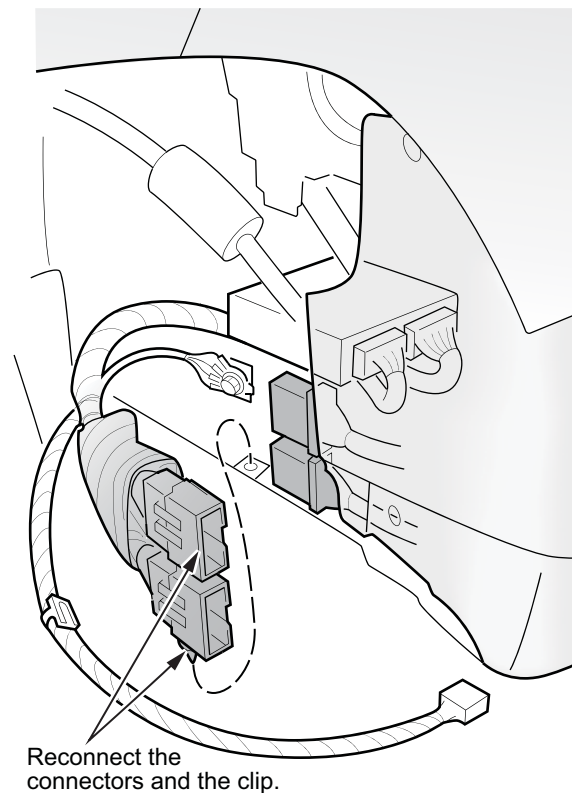

18. Route the noise suppressor subharness as shown.

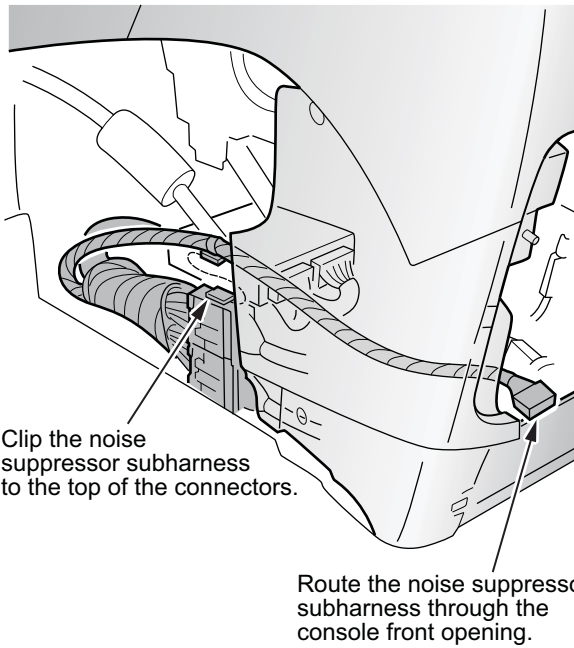

19. Remove the antenna feeder line clip, and install the noise suppressor bracket using the nut and bolt from the kit.

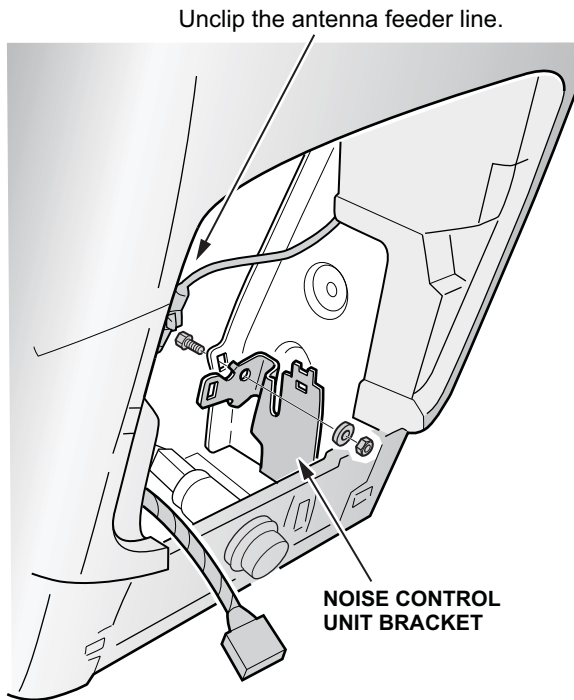

20. Connect the connector to the noise suppressor.

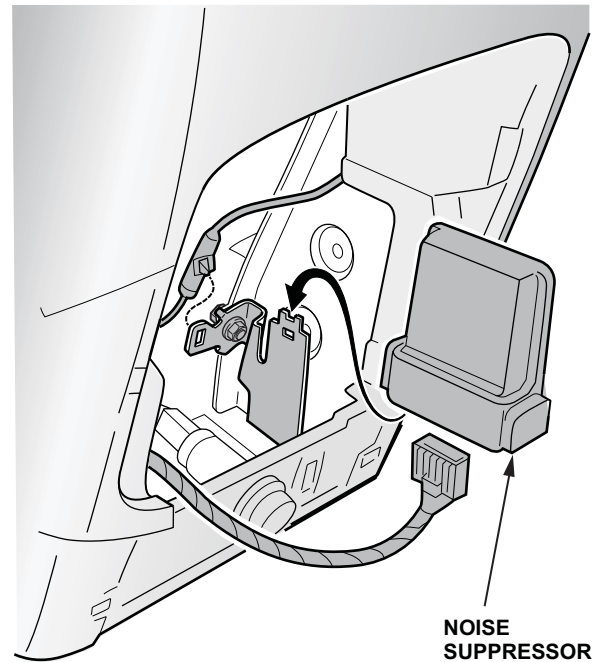

21. Install the noise suppressor onto the bracket.

22. Reinstall the heater covers, the center lower pocket, and the center console trim.

23. Reconnect the negative battery cable.

24. Start the engine and confirm the SRS indicator comes on and goes off after about 6 seconds.

NOTE: If the SRS indicator was on when the vehicle arrived at the dealership, it will remain on.

25. Enter the anti-theft codes for the audio and navigation system, then enter the customer's radio presets.

26. Reset the power window control unit:

- Turn the ignition switch to LOCK (0), then back to ON (II).
- Press the driver's window switch firmly to the second detent to lower the window all the way down.
- When the window reaches the bottom, hold the driver's window switch in the DOWN position for 2 seconds.
- Pull the driver's window switch and hold it to the second detent to raise the window without stopping.
- When the window reaches the top, hold the driver's window switch in the UP position for 2 seconds.

27. *Vehicles without navigation*: Set the clock.

28. Do the idle learn procedure.

- Make sure all electrical items (A/C, audio unit, defogger, lights, etc.) are off.
- Start the engine, and let it warm up to its normal operating temperature (the cooling fans cycle twice).
- Let the engine idle (throttle closed and all electrical items off) for 10 minutes.