



Recall Bulletin



FMVSS NONCOMPLIANCE RECALL

SUBJECT: Rear Brake Caliper Bracket Bolt Torque

MODELS: 2014 Chevrolet Suburban, Tahoe
2014 GMC Yukon, Yukon XL

Vehicles involved in this recall were placed on stop delivery July 26, 2013. All involved vehicles that are in dealer inventory must be held and not delivered to customers, dealer traded, or used for demonstration purposes until the repair contained in this bulletin has been performed on the vehicle. Once the procedure is performed, the vehicle is released from stop delivery and can be delivered to the customer.

CONDITION

General Motors has decided that certain 2014 model year Chevrolet Suburban and Tahoe, and GMC Yukon and Yukon XL vehicles may fail to conform to Federal Motor Vehicle Safety Standard 135 for braking systems. On some of these vehicles, the rear brake caliper bracket bolts may not be fully tightened. This could produce a noise when the vehicle is driven and may result in reduced brake system performance, including a longer distance to stop the vehicle. If stopping distance is increased, a vehicle crash could occur.

CORRECTION

Dealers are to inspect the bolts on both rear brake caliper brackets. If a bolt on either of the rear brake caliper brackets is not fully tightened, dealers are to install two new bolts on affected rear brake caliper bracket.

VEHICLES INVOLVED

All involved vehicles are identified by Vehicle Identification Number on the Investigate Vehicle History screen in GM Global Warranty Management system. Dealership service personnel should always check this site to confirm vehicle involvement prior to beginning any required inspections and/or repairs. It is important to routinely use this tool to verify eligibility because not all similar vehicles may be involved regardless of description or option content.

For dealers with involved vehicles, a listing with involved vehicles containing the complete vehicle identification number, customer name, and address information has been prepared and will be provided to dealers through the GM GlobalConnect Recall Reports. Dealers will not have a report available if they have no involved vehicles currently assigned.

The listing may contain customer names and addresses obtained from Motor Vehicle Registration Records. The use of such motor vehicle registration data for any purpose other than follow-up necessary to complete this recall is a violation of law in several states/provinces/countries. Accordingly, you are urged to limit the use of this report to the follow-up necessary to complete this recall.

PART INFORMATION

Parts required to complete this recall are to be obtained from General Motors Customer Care and Aftersales (GMCC&A). Please refer to your "involved vehicles listing" before ordering parts. Normal orders should be placed on a DRO = Daily Replenishment Order. In an emergency situation, parts should be ordered on a CSO = Customer Special Order.

Important: It is estimated that no more than 1 of the involved vehicles will require bolt replacement. Please order parts accordingly.

Part Number	Description	Quantity/Vehicle
15012506	BOLT, RR BRK CLPR	2 or 4 (if req'd)

SERVICE PROCEDURE

1. Raise and support the vehicle. Refer to *Lifting and Jacking the Vehicle* in SI.

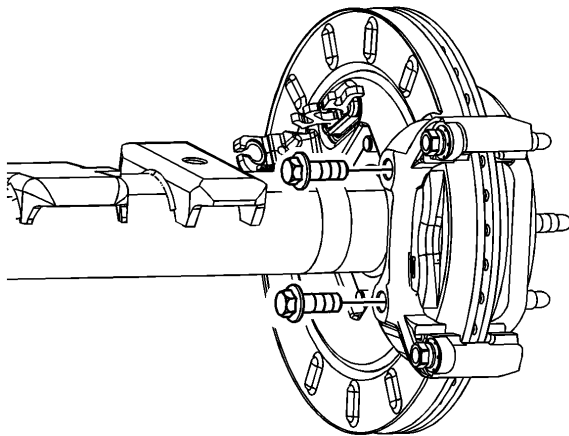

1497142

Note: There are two brake caliper bracket bolts for each caliper bracket.

2. Locate the rear brake caliper bracket bolts on the driver and passenger side of vehicle.

3. Using a torque wrench, verify that the rear brake caliper bracket bolts have been tightened to 165 N·m (122 lb ft).
 - If the rear brake caliper bracket bolts are tightened to 165 N·m (122 lb ft), no further action is required. Lower the vehicle. *Refer to Lifting and Jacking the Vehicle in SI.*
 - If a rear brake caliper bracket bolt is loose or has NOT been tightened to 165 N·m (122 lb ft), remove and discard both bolts on that rear brake caliper bracket. Install two new rear brake caliper bracket bolts and tighten the bolts to 200 N·m (148 lb ft).

FLOOR PLAN REIMBURSEMENT

Dealers in possession of vehicles included in the Stop Delivery are eligible for reimbursement of floor plan expense upon completion of this recall. This reimbursement is limited to the number of days from the Stop Delivery message to receipt of the recall parts and/or repair procedures. Floor plan reimbursement beyond these dates is not allowed. The amount of reimbursement should be charged as a net amount expense using the recall labor operation provided.

COURTESY TRANSPORTATION

The General Motors Courtesy Transportation program is intended to minimize customer inconvenience when a vehicle requires a repair that is covered by the New Vehicle Limited Warranties. The availability of courtesy transportation to customers whose vehicles are within the warranty coverage period and involved in a product program is very important in maintaining customer satisfaction. Dealers are to ensure that these customers understand that shuttle service or some other form of courtesy transportation is available and will be provided at no charge. Dealers should refer to the General Motors Service Policies and Procedures Manual for Courtesy Transportation guidelines.

WARRANTY TRANSACTION INFORMATION

Submit a transaction using the table below. All transactions should be submitted as a ZFAT transaction type, unless noted otherwise.

Labor Code	Description	Labor Time
9100107	Inspect Rear Brake Caliper Bracket Bolts – No Further Action Req'd	0.3
9100114	Inspect & Replace Rear Brake Caliper Bracket Bolt(s)	0.4
9100116	Floor Plan Reimbursement	*

* The amount identified in the "Net Item" column should represent the product of the vehicle's average daily interest rate (see table below) multiplied by the actual number of days the vehicle was in dealer inventory and not available for sale. This reimbursement is limited to the number of days from the date of the stop delivery message (July 26, 2013) to the date the repair is completed and the vehicle is ready for sale (not to exceed 9 days):

Vehicle	US Reimbursement Amount
Suburban	\$7.93
Tahoe	\$7.03
Yukon	\$7.64
Yukon XL	\$8.11

CUSTOMER NOTIFICATION

General Motors will notify customers of this recall on their vehicle.

DEALER RECALL RESPONSIBILITY

It is a violation of Federal law for a dealer to deliver a new motor vehicle or any new or used item of motor vehicle equipment (including a tire) covered by this notification under a sale or lease until the defect or noncompliance is remedied.

The US National Traffic and Motor Vehicle Safety Act provides that each vehicle that is subject to a recall of this type must be adequately repaired within a reasonable time after the customer has tendered it for repair. A failure to repair within sixty days after tender of a vehicle is prima facie evidence of failure to repair within a reasonable time. If the condition is not adequately repaired within a reasonable time, the customer may be entitled to an identical or reasonably equivalent vehicle at no charge or to a refund of the purchase price less a reasonable allowance for depreciation. To avoid having to provide these burdensome remedies, every effort must be made to promptly schedule an appointment with each customer and to repair their vehicle as soon as possible. In the recall notification letters, customers are told how to contact the US National Highway Traffic Safety Administration if the recall is not completed within a reasonable time.

This bulletin is notice to you that the new motor vehicles included in this recall may not comply with the standard identified above. Under Title 49, Section 30112 of the United States Code, it is illegal for a dealer to sell a new motor vehicle which the dealer knows does not comply with an applicable Federal Motor Vehicle Safety Standard. As a consequence, if you sell any of these motor vehicles without first performing the recall correction, your facility may be subject to a civil penalty for each such sale.

All unsold new vehicles in dealer's possession and subject to this recall must be held and inspected/repaired per the service procedure of this recall bulletin before customers take possession of these vehicles.

Dealers are to service all vehicles subject to this recall at no charge to customers, regardless of mileage, age of vehicle, or ownership, from this time forward.

Customers who have recently purchased vehicles sold from your vehicle inventory, and for which there is no customer information indicated on the dealer listing, are to be contacted by the dealer. Arrangements are to be made to make the required correction according to the instructions contained in this bulletin. Recall follow-up cards should not be used for this purpose, since the customer may not as yet have received the notification letter.

In summary, whenever a vehicle subject to this recall enters your vehicle inventory, or is in your facility for service in the future, you must take the steps necessary to be sure the recall correction has been made before selling or releasing the vehicle.

