



Applies To: **2013 Accord** – Check the iN VIN status for eligibility

August 3, 2013

Safety Recall: Fuel Tank Leaking at Fuel Tank Unit

(Supersedes 13-054, dated July 6, 2013, to revise the information marked by the black bars)

REVISION SUMMARY

Under REPAIR PROCEDURE, a step was added to fill out a Vehicle Emissions Recall - Proof of Correction certificate.

BACKGROUND

The threaded part of the fuel tank, where the fuel tank unit is installed, may be out of specification.

CUSTOMER NOTIFICATION

Owners of affected vehicles will be sent a notification of this campaign.

Do an **iN VIN status inquiry** to make sure the vehicle is shown as eligible.

Some vehicles affected by this campaign may be in your new or used vehicle inventory. These vehicles **must** be repaired before they are sold.

Should your dealership sell an unrepaired vehicle that subsequently causes injury or damage because of the recalled item, the dealership will be solely responsible to the damaged party, and will be required to defend and indemnify American Honda for any resulting claims. To see if a vehicle in inventory is affected by this recall, do a VIN status inquiry before selling it.

CORRECTIVE ACTION

Replace the fuel tank.

PARTS INFORMATION

NOTE: To help clarify where new parts are used in the REPAIR PROCEDURE, the new part is listed in the applicable step with a ">" symbol.

Fuel Tank Set:

2-Door: P/N 17044-T3L-A00

4-Door: P/N 17044-T2A-A00

(Both sets include fuel tank, gasket, and locknut)

Exhaust Pipe Gasket:

V6 and Sport: P/N 18303-T2B-A01

L4: P/N 18302-SP0-003

Pre-Chamber Gasket (V6 and Sport only):

P/N 18393-SDB-A00

10 mm Self-locking Nut (three required for L4 except Sport; six required for Sport and V6):

P/N 90212-SA5-003

TOOL INFORMATION

Fuel Nut Wrench: T/N 07AAA-T0AA100

WARRANTY CLAIM INFORMATION

Operation Number: 3101X1

Flat Rate Time: 1.6 hour

Failed Part: P/N 17044-T2A-A00

Defect Code: 5LY00

Symptom Code: JA900

Skill Level: Repair Technician

REPAIR PROCEDURE

NOTE: The following service manual procedures have been used in full or in part within this service bulletin. For more detail on these procedures, refer to them online.

- Fuel Tank Draining
- Fuel Tank Unit Removal and Installation
- Fuel Pressure Relieving
- Battery Terminal Disconnection and Reconnection
- Rear Seat Removal and Installation
- Rear Floor Undercover Removal and Installation
- Exhaust Pipe and Muffler Removal and Installation
- Rear Inner Fender Removal and Installation

1. Park the vehicle on a lift.
2. Remove the bolt between the rear seat-back and the rear seat cushion.

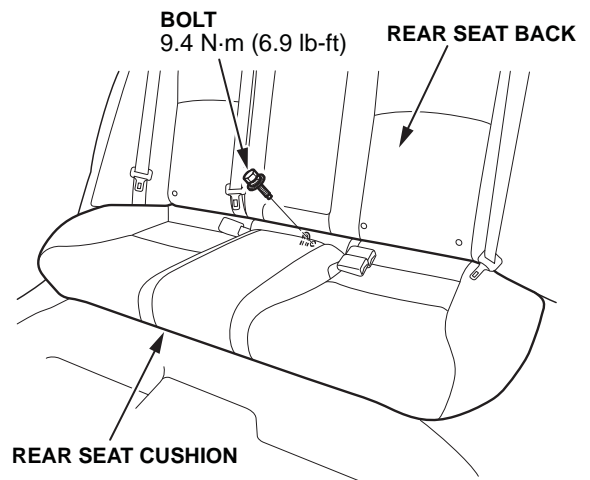

3. Release the rear seat hooks:
 - 2-Door: Release the hooks.
 - 4-door: While pushing down on the seat cushion, pull the seat hook handles to release the hooks.

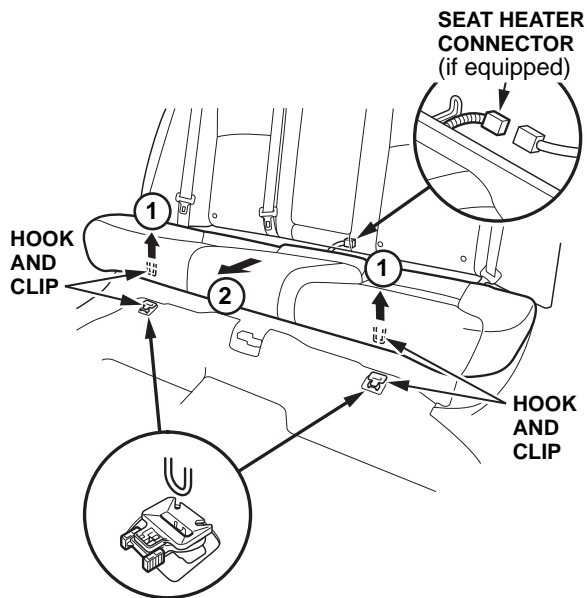

4. Remove the rear seat cushion.

NOTE: Disconnect the rear seat heater connector (if equipped).

5. Remove the access panel from the floor, and disconnect the fuel tank unit connector.

NOTE: If the vehicle came in with DTC P0455 (EVAP System Large Leak Detected) or P0456 (EVAP System Very Small Leak Detected), check for fuel leaks around the fuel tank unit. If you see or smell any leaks, the DTCs were likely caused by a leak around the fuel tank unit.

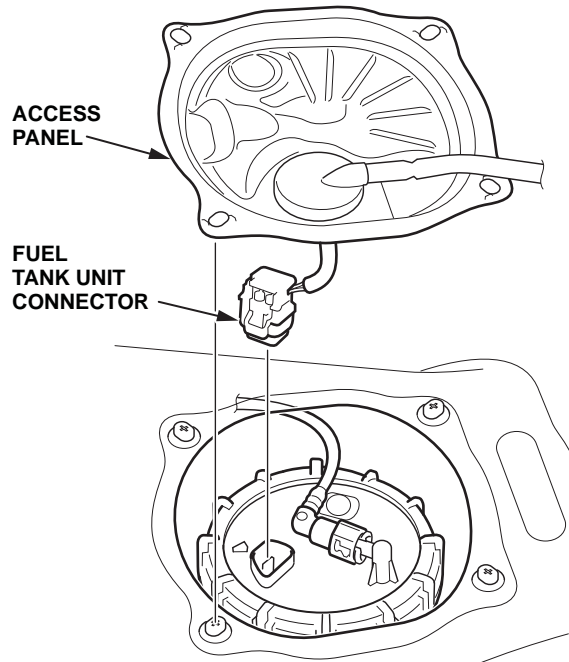

6. Place a rag or shop towel over the fuel tank unit quick-connect fitting, then disconnect the quick-connect fitting from the fuel tank unit.

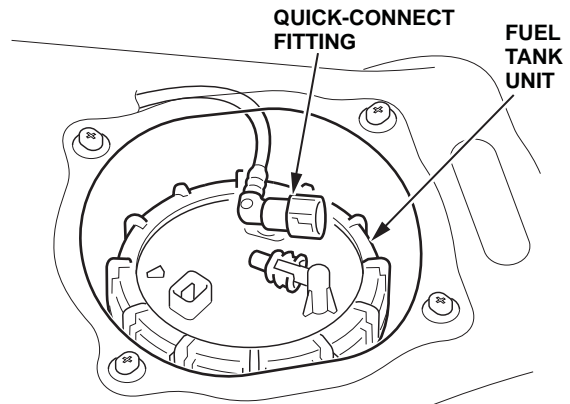

7. Using a fuel nut wrench, loosen the fuel tank unit locknut, then remove it.

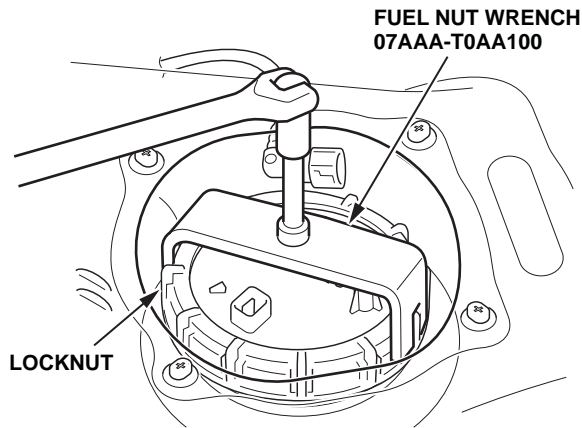

8. Remove the fuel tank unit.

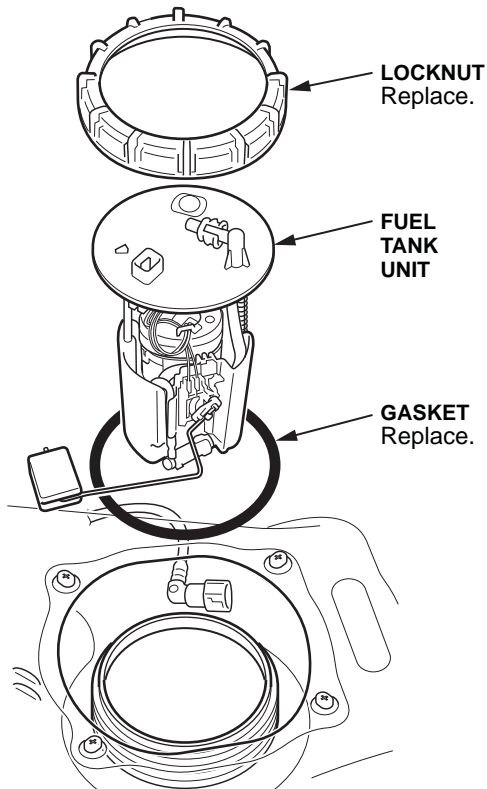

9. Using a hand pump, a hose, and an approved fuel storage container, drain the fuel tank.

10. Raise the vehicle.

11. Remove the rear floor undercover.

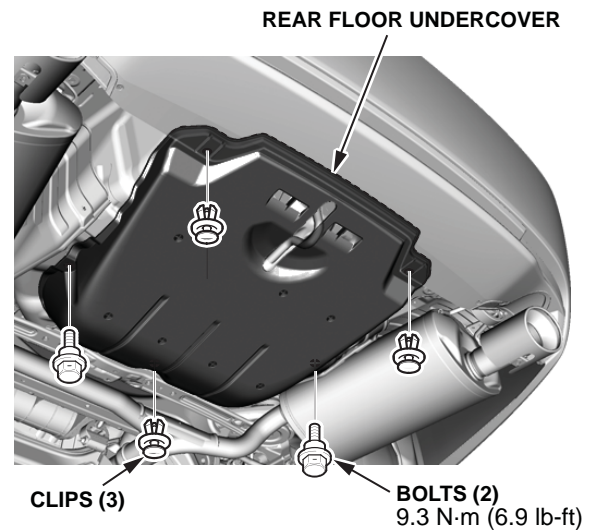

12. Remove exhaust pipe B.

V6 and SPORT MODELS

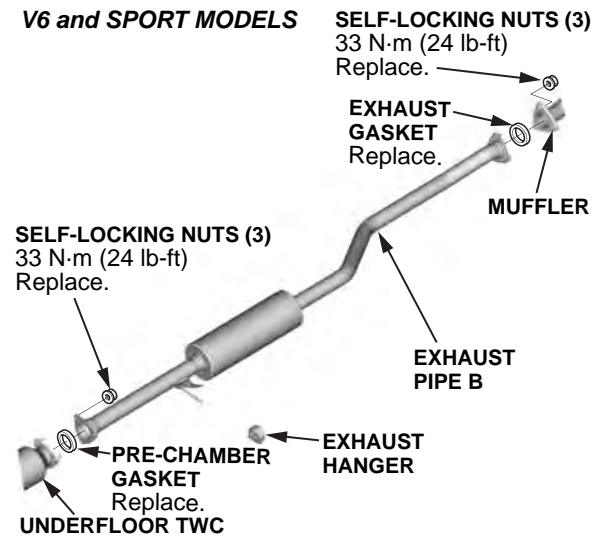

L4 MODELS

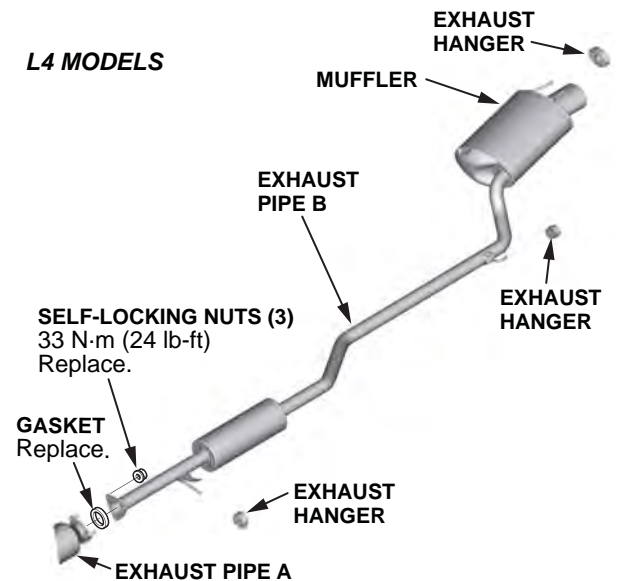

13. Remove the left rear inner fender.

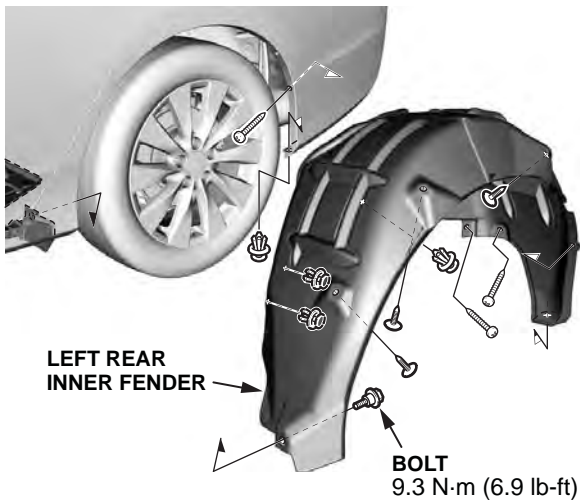

14. Remove the fuel fill pipe cover.

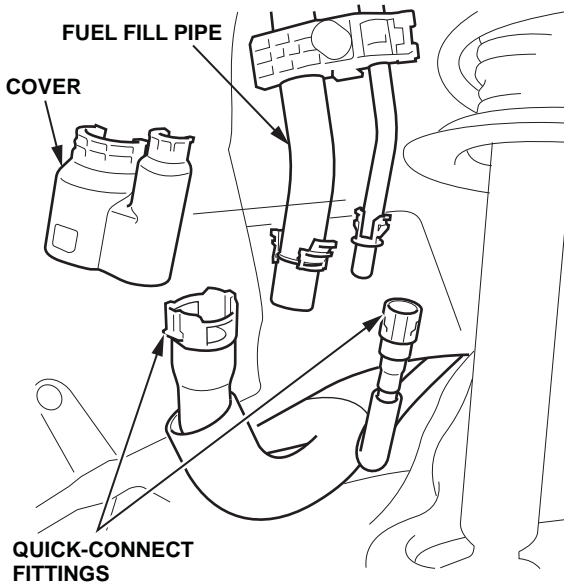

15. Disconnect the quick-connect fittings from the fuel fill pipe and the fuel fill vent hose.

16. Remove the fuel fill vent hose from the clamp, and disconnect the fuel vapor hose.

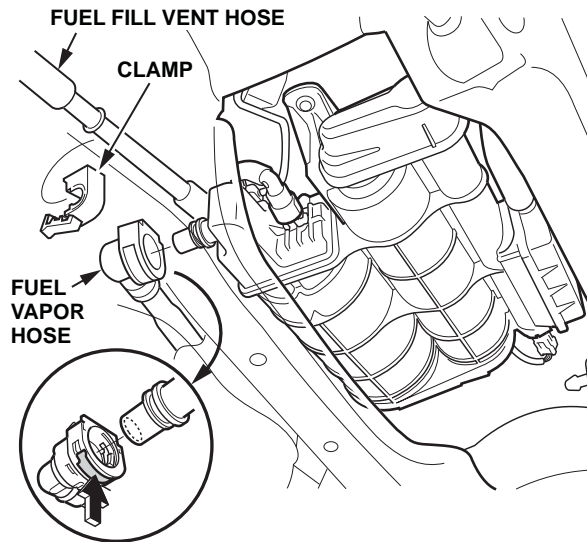

17. Remove the fuel tank protector.

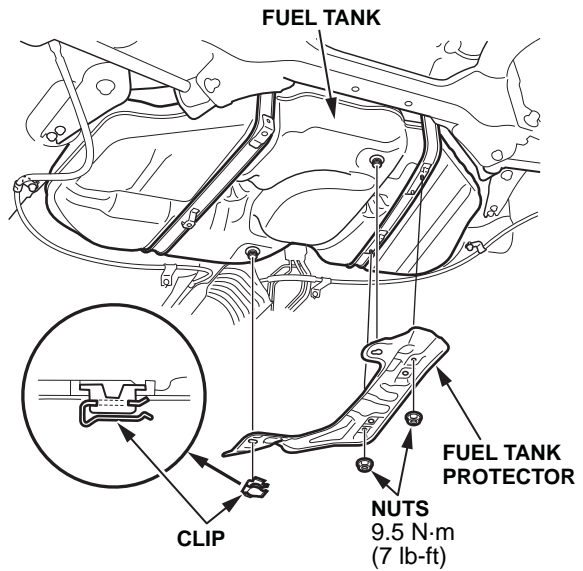

18. Remove the parking brake cable mounting bolts.

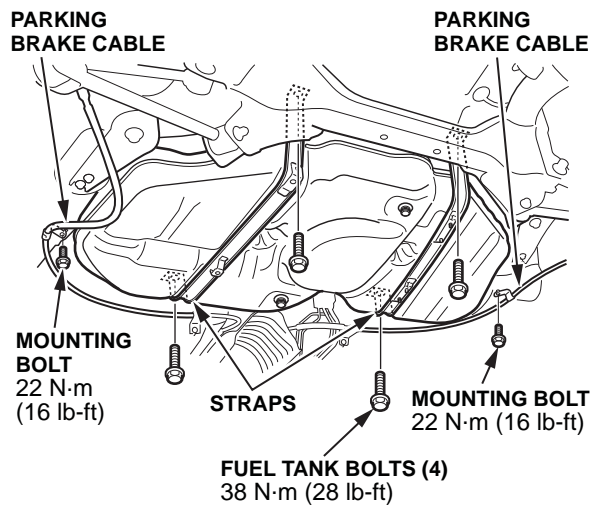

19. Place a jack or other support under the fuel tank.
20. Remove the fuel tank straps, then carefully remove the fuel tank.
21. Transfer the original fuel tank unit to the new fuel tank. Do not install the fuel tank unit yet.
> Fuel Tank
22. Raise the new fuel tank into position, then reinstall the fuel tank straps. Torque the bolts to **38 N·m (29 lb-ft)**.
23. Install the parking brake cable. Torque the mounting bolts to **22 N·m (16 lb-ft)**.

24. Install the fuel tank protector and torque the nuts to **9.5 N·m (7 lb-ft)**.

NOTE: Make sure you insert the clip in the direction shown.

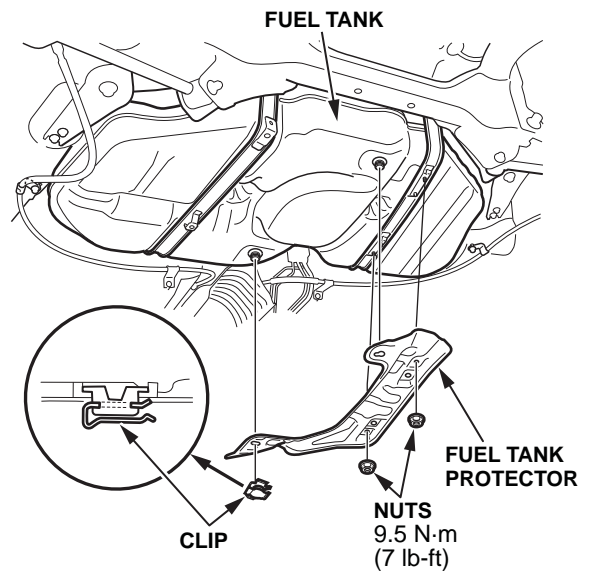

25. Connect the fuel vapor hose, and reinsert the fuel fill vent hose into the clamp.
26. Connect the fuel fill pipe and the fuel fill vent hose quick-connect fittings, then reinstall the fuel fill pipe cover.
27. Install the left rear inner fender. Torque the bolt to **9.3 N·m (6.9 lb-ft)**.
28. Install exhaust pipe B. Torque the nuts to **33 N·m (24 lb-ft)**.
> Nuts (3 - L4 except Sport) (6 - Sport and V6)
> Exhaust Pipe Gasket
> Pre-Chamber Gasket
29. Install the rear floor undercover. Torque the bolts to **9.3 N·m (6.9 lb-ft)**.

30. Partially install the fuel tank unit. Make sure you use the new gasket from the set.

> Gasket

NOTE:

- Be careful not to damage the new gasket.
- Be careful not to bend the fuel gauge sending unit.
- Do not coat the base gasket with oil.

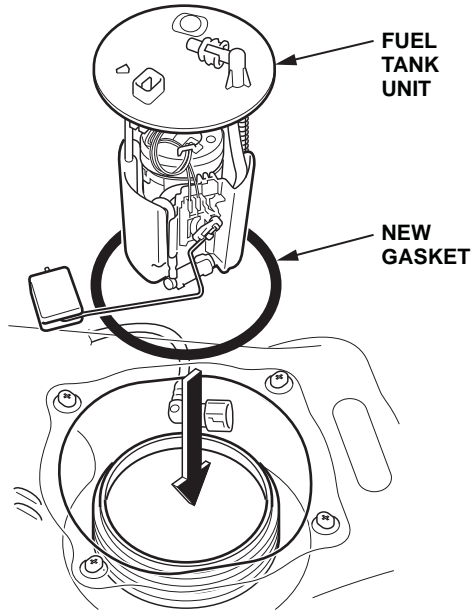

31. Align the marks on the fuel tank and fuel tank unit, then insert the fuel tank unit completely into the fuel tank.

NOTE: To avoid a fuel leak, check the gasket, visually or by hand, to make sure it is not pinched.

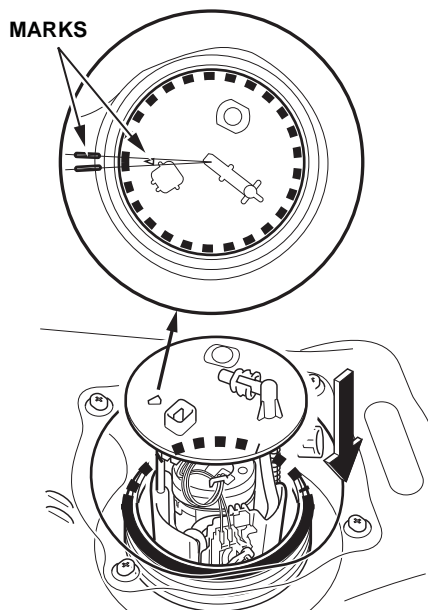

32. Position the new locknut on top of the fuel tank unit, making sure to align the mark on the locknut to the start of the thread. Then, hand-tighten the locknut, holding the unit so it does not move.

> Locknut

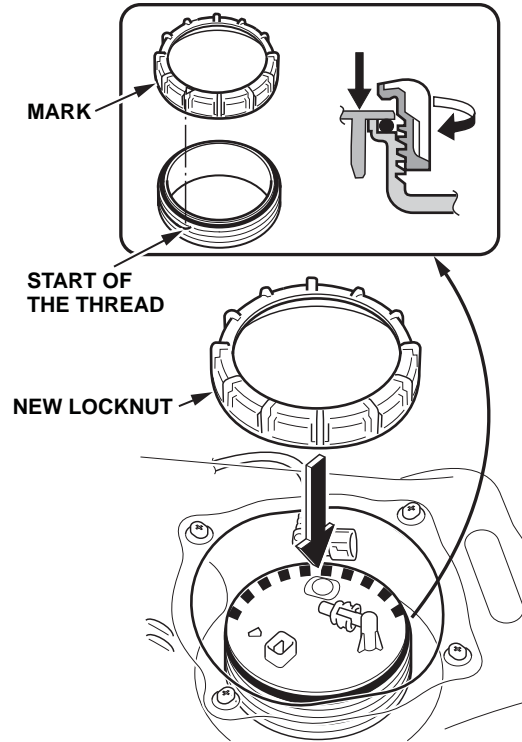

33. Using the fuel nut wrench, torque the locknut to **100 N•m (74 lb-ft)**.

NOTE:

- After tightening, make sure the marks on the fuel tank and the fuel tank unit are still aligned.
- After installation, check the gasket, visually or by hand, to make sure it is not pinched.

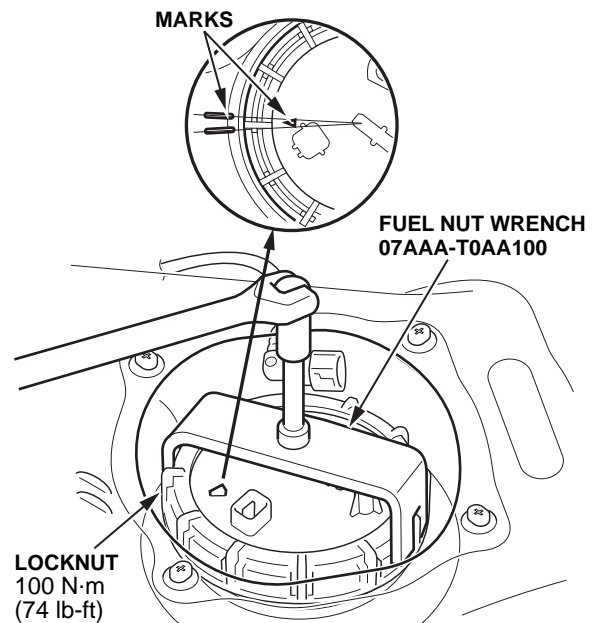

34. Connect the quick-connect fitting to the fuel tank unit.
NOTE: Replace the retainer only if it is damaged or if it was **removed from the line**.
35. Connect the fuel tank unit connector.
36. Pour the drained fuel into the fuel tank.
37. Turn the ignition switch to ON (II), or press the engine start/stop button to select the ON mode (but do not operate the starter motor). The fuel pump runs for about 2 seconds, raising the fuel pressure. Repeat this two or three times.
38. Make sure there are no fuel leaks.
39. Install the access panel.
40. Install the rear seat cushion. Torque the bolt to **9.4 Nm (6.9 lb-ft)**.
41. **For California residents only:** Fill out a Vehicle Emissions Recall - Proof of Correction certificate, and use JA9 as the recall number. Give the certificate to your customer, and advise him or her to keep it as proof that the product update was completed. Your customer will need to submit this certificate to the DMV only if the DMV requests it. If you need more certificates, use reorder number Y0657.

The image shows a "Vehicle Emission Recall - Proof of Correction" form. At the top, there are fields for License Number, Make, Year Model, Body type, and Vehicle Identification Number. Below these is a field for Recall Number, which contains "JA9" circled in blue. The form also includes fields for Manufacturer, Dealer's Name, Address, City, State and Zip, Date, and Dealership's Authorized Signature. A checkbox is present next to the signature line. At the bottom, there is a note: "Return this certificate to DMV only when required - otherwise retain for your records." The form number "HCL 34952 (2/12)" is visible in the bottom right corner.