



# Campaign Service

## BULLETIN

### IMPORTANT SERVICE INFORMATION FOR:

- ✓ SERVICE MANAGER
- ✓ SERVICE ADVISOR
- ✓ TECHNICIAN
- ✓ PARTS DEPARTMENT
- ✓ WARRANTY PERSONNEL

BULLETIN NUMBER:  
**SB13-04-S003**

ISSUE DATE:  
**JULY 2013**

GROUP:  
**ELECTRICAL**

## SAFETY RECALL



LV

### DRIVER DOOR SWITCH SHORT CIRCUIT #13V-248

#### AFFECTED VEHICLES

- 2006-2007MY Isuzu Ascender Vehicles

Vehicles originally involved in "Special Policy Adjustment – Driver Door Switch Short Circuit" but that have not had the repair performed, have been transferred to this safety recall. Please discard all copies of bulletin **SB13-04-S002**.

#### SERVICE INFORMATION

#### CONDITION

The manufacturer of your vehicle, General Motors, has decided that a defect, which relates to motor vehicle safety, exists in certain 2006-2007 Isuzu Ascender vehicles.

If fluid enters the driver's door module, it may cause corrosion that could result in a short in the circuit board. A short may cause the power door lock and power window switches to function intermittently or become inoperative. In rare cases, a short may cause overheating, which could melt components of the door module, producing odor, smoke, or a fire.

#### CORRECTION

Service Facilities are to test the driver's window and door lock switches for proper operation. If the switches function properly, Service Facilities are to inspect the module, and, if necessary, install a protective coating. If the switches do not function properly, Service Facilities are to install a new door module.

#### VEHICLES INVOLVED

Involved are certain 2006-2007 model year Isuzu Ascender.

**Important:** Service Facilities are to confirm vehicle eligibility prior to beginning repairs by using the Isuzu Communication System (ICS).

For Service Facilities with involved vehicles, a listing of involved vehicles containing the complete vehicle identification number has been or will be provided. Service Facilities will not have a report available if they have no involved vehicles currently assigned.

## SERVICE PROCEDURE

1. Perform a functional test on the driver side door lock and side window switch. Test all switch functions to ensure the driver side door lock and side window switch functions as designed.
  - a) If the driver side door lock and side window switch passes the functional test, proceed to Step 2.
  - b) If the driver side door lock and side window switch does NOT pass the functional test, replace the driver side door lock and side window switch. Refer to *Door Lock and Side Window Switch Replacement – Driver Side* in the service manual. After completing the replacement of the door lock and side window switch, proceed to Step 19 of this bulletin, “Applying the Campaign Label”.

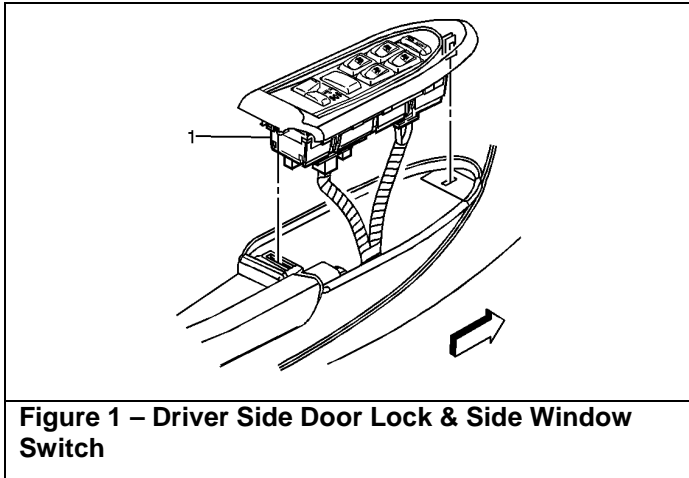

2. Remove the driver side door lock and side window switch. Refer to *Door Lock and Side Window Switch Replacement - Driver Side* in the service manual.

Part Number	Description
25866992	SWITCH, DR LK & SI WDO
25866993	SWITCH, DR LK & SI WDO
25866994	SWITCH, DR LK & SI WDO
25866996	SWITCH, DR LK & SI WDO

3. Determine the part number on the driver side door lock and side window switch. The part number is on the side of the switch on the label (See Figure 2).
  - a) If the part number on the switch is listed in the parts table above, no repair is required. Re-install the driver side door lock and side window switch. Refer to *Door Lock and Side Window Switch Replacement – Driver Side* in the service manual, and then proceed to Step 19 of this bulletin, “Applying the Campaign Label”.
  - b) If the part number on the switch is NOT listed on the table above, proceed to Step 4.

**Caution: To avoid part damage, ensure your hands and work bench are clean BEFORE performing the door lock and side window switch and door module modifications in this bulletin.**

4. Place the driver side door lock and side window switch assembly on a clean work bench.

5. Separate the door module from the door lock and side window switch assembly.

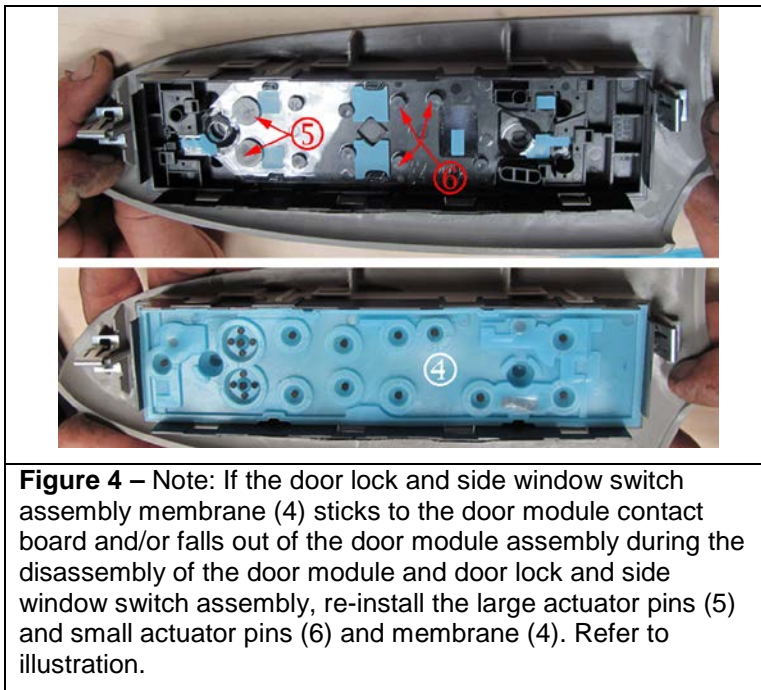
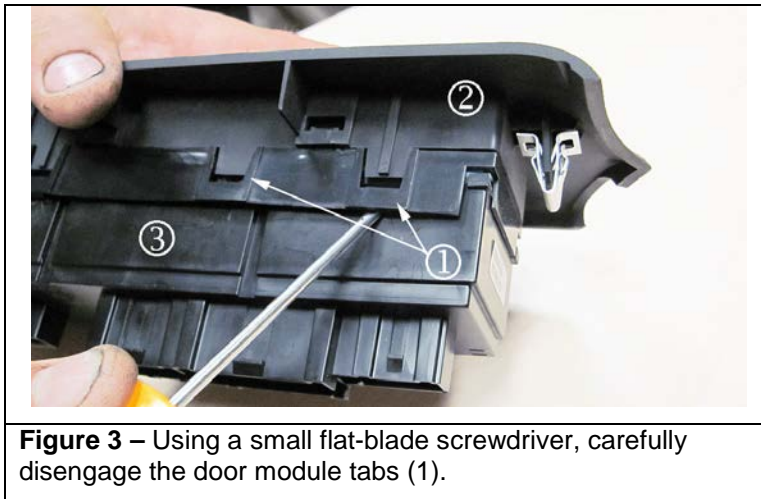
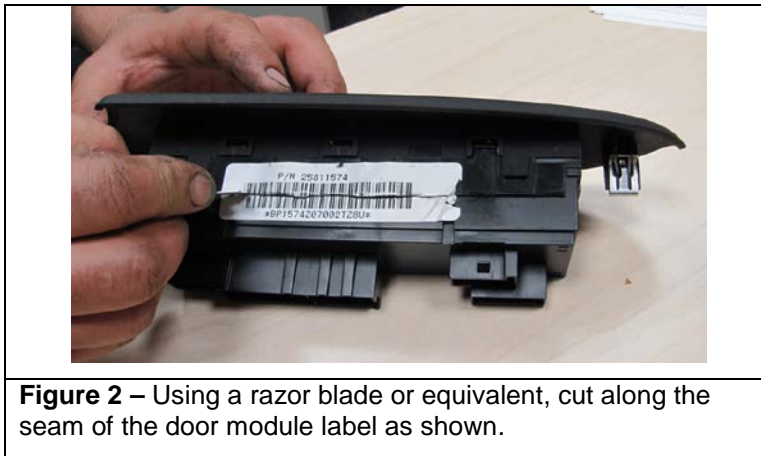

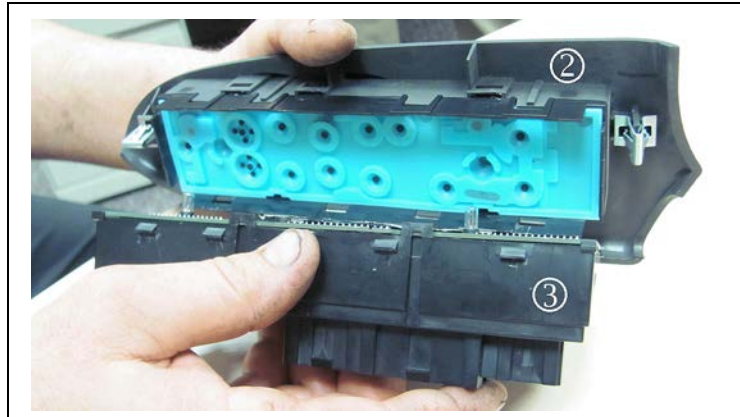
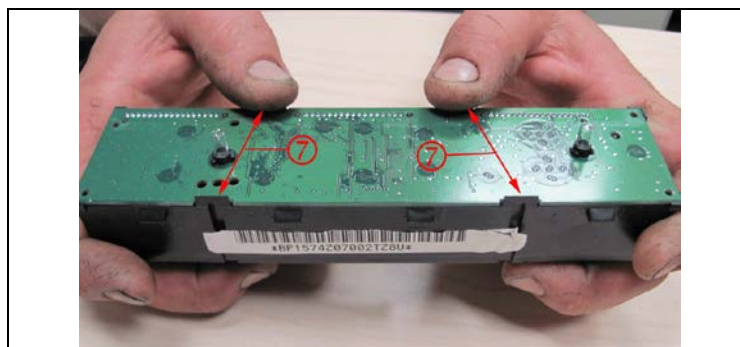

**Figure 5** – Separate the door module (3) from the door lock and side window switch assembly (2).

6. Place the door lock and side window switch assembly in a safe location while modifying the door module.

Note: Refer to Door Module Repair Tips in this bulletin before performing Steps 7 through 16.

7. Separate the contact board from the door module housing by depressing the contact board tabs (7). Do NOT remove the contact board from the door module housing.



**Figure 6** -

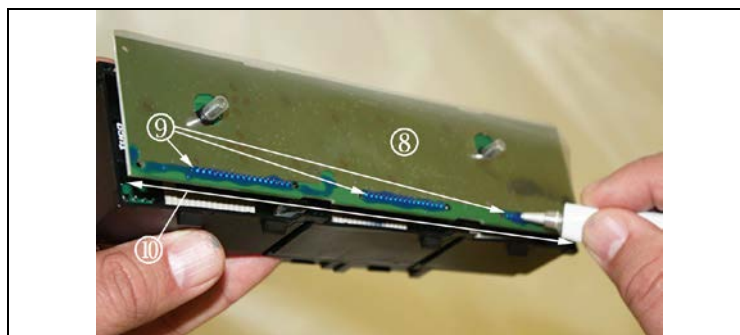

**Figure 7** – Note: Do NOT attach the ESD protective barrier (8) over the connector pins (9).

**Note:** Before removing the cap from the protective coating tube, squeeze/knead the tube to ensure that the contents of the tube are thoroughly mixed. Dispense a small amount of the protective coating on a clean piece of paper to ensure that the material is a consistent dark blue color.

**Note:** Do not substitute paper or cardboard for the ESD protective barrier.



**Note:** Do NOT attach the ESD protective barrier (8) over the connector pins (9).

8. Remove the backing paper from the ESD protective barrier (8) and attach it to the contact board. Attach the ESD protective barrier (8) along the edge of the connector pins (9). See Figure 7.
9. Apply the protective coating to the top side of the contact board. Apply the protective coating over the entire length (10) of the contact board from the ESD protective barrier tape edge (8) to the contact board edge.

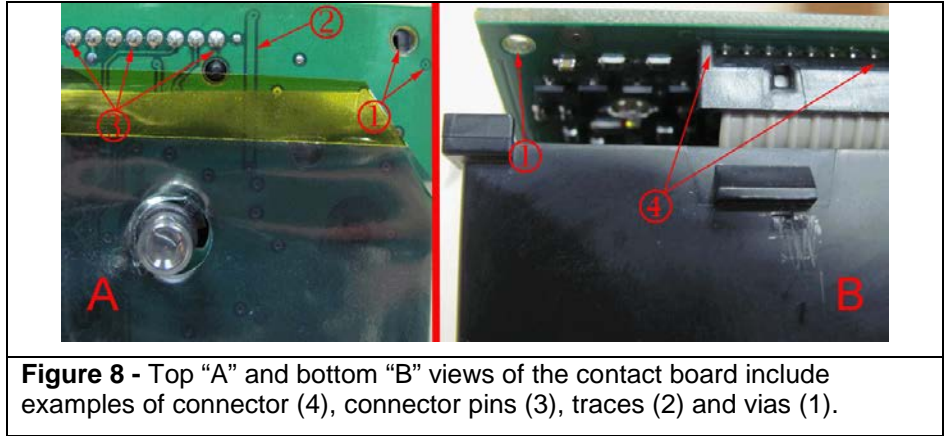

10. Ensure the protective coating covers the connector pins, traces and vias (holes) in the application area of the contact board.

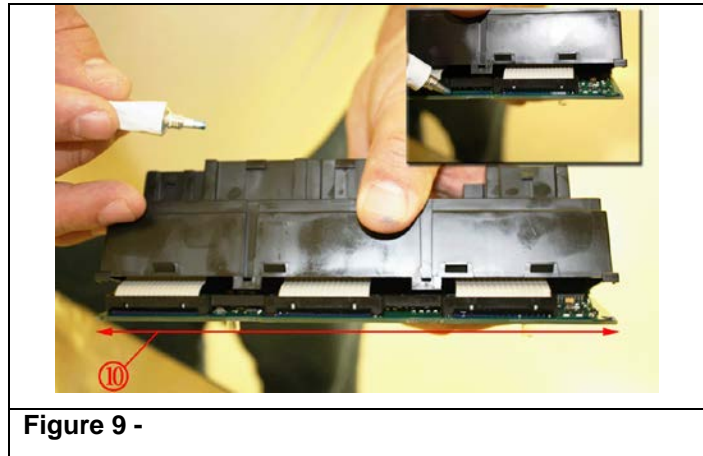

11. Apply the protective coating to the bottom side of the contact board. Apply the protective coating over the entire length (10) of the contact board.

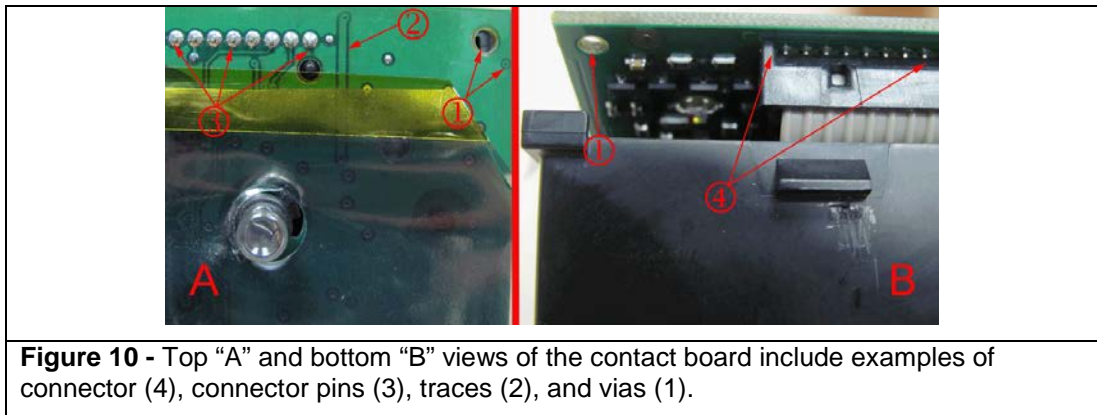

12. Ensure the protective coating covers the connector pins, traces and vias (holes) in the application area of the contact board.

**Caution: The cure time for the material is 1 hour. To avoid part damage, do NOT proceed to Step 13 until the material has cured for 1 hour.**

13. Wait 1 hour to allow the liquid material to cure to a “tacky” state.

14. Remove ESD protective barrier from the contact board of the door module.



15. Insert the Mylar Kapton<sup>®</sup> gasket (10) to the inside surface covering the open cutouts of the door lock and side window switch membrane.

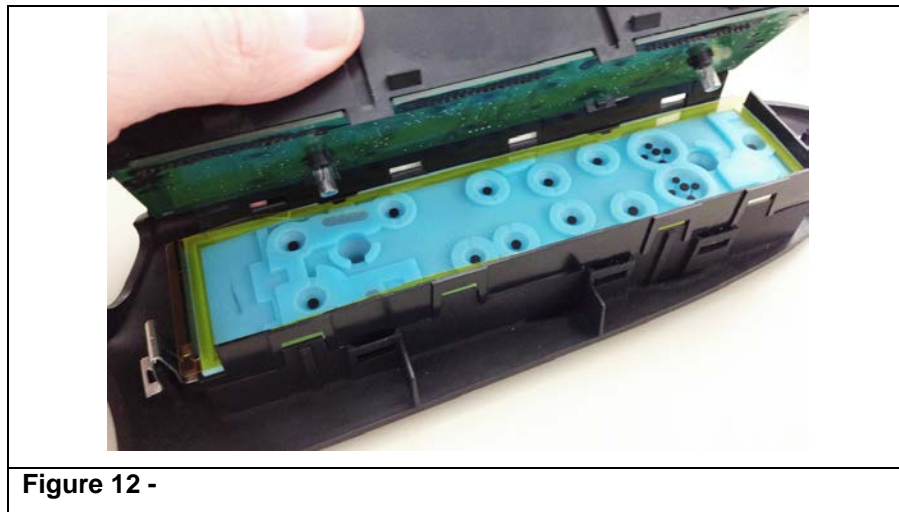

16. Assemble the door module and door lock and side window switch.

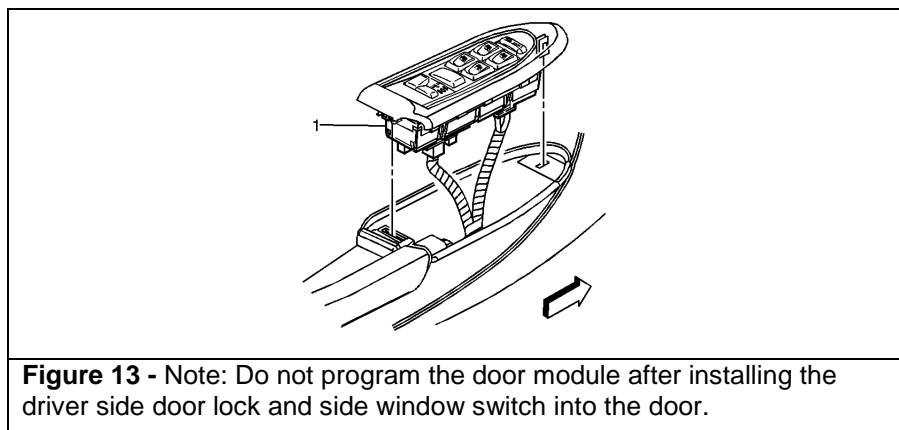

**Figure 13 - Note: Do not program the door module after installing the driver side door lock and side window switch into the door.**

17. Install the driver side door lock and side window switch into the door. Refer to *Door Lock and Side Window Switch Replacement - Driver Side* in the service manual.
18. Perform a functional test on the driver side door lock and side window switch. Test all switch functions to ensure the driver side door lock and side window switch functions as designed. Replace the driver side door lock and side window switch if it fails the functional test. Refer to *Door Lock and Side Window Switch Replacement - Driver Side* in the service manual then proceed to Step 19, "Applying the Campaign Label".
19. Applying the Campaign Label
  - a) Using a ball-point pen, fill in a campaign label (P/N 2-90028-700-0) with Campaign Number 13V-248, Isuzu service facility code and repair date.
  - b) Affix the campaign label onto the driver's side B-pillar.

<b>ISUZU</b>
<b>CAMPAIGN NUMBER</b>
_____
<b>DEALER CODE:</b> _____
<b>REPAIR DATE:</b> _____
<b>P/N 2-90028-700-0</b>

### DOOR MODULE REPAIR TIPS

To ensure the door module repair is completed correctly, refer to the following repair tips.

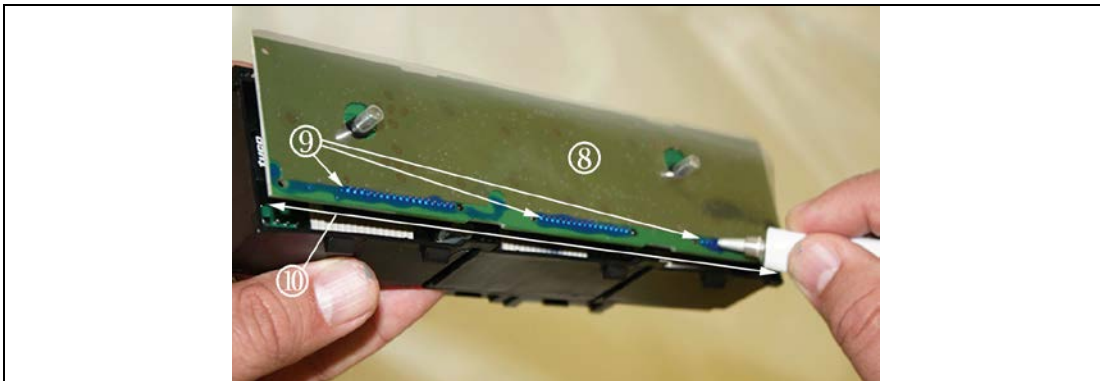
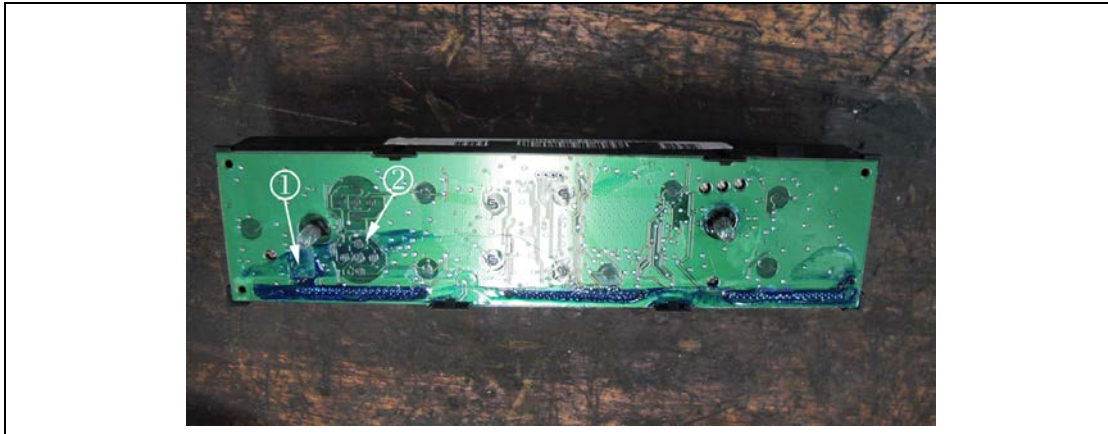

Figure 14 -

- Ensure the protective coating covers the connector pins, traces and vias (holes) in the application area of the contact board. Apply the protective coating to the top side of the contact board. Apply the protective coating over the entire length (10) of the contact board from the ESD protective barrier tape edge (8) to the contact board edge.



**Figure 15 -**

- Do NOT apply the protective coating to the contact board (1) and switch contact points (2) underneath the ESD protective barrier.



**Figure 16 -**

- The cure time for the protective coating is 1 hour. To avoid part damage, do NOT remove the ESD protective barrier (1) or assemble the door module until the protective coating has cured.
- Remove the ESD protective barrier (1) from the contact board BEFORE assembling the door module. Do NOT assemble the door module with the ESD protective barrier on the contact board.

**PARTS INFORMATION**

Parts required to complete this campaign are to be obtained from American Isuzu Parts Distribution Network (AIPDN). Please refer to your “involved vehicles listing” before ordering parts. Normal orders should be placed on a Daily Order. In an emergency situation, parts should be ordered on a VOR (Vehicle Off Road) Order.

Part Number	Description	Quantity
8-19119-236-0	SWITCH KIT, SI WDO	1



## CLAIM INFORMATION

Refer to the Isuzu ICS Claims Processing Manual for details on Campaign Claim Submission.

Submit only **one** claim with the applicable Labor Code as indicated below.

Labor Code	Description	Trouble Code	Labor Time	Net Item
04X2739	Functional Test & Verify Part Number – No Further Action Req'd	07	0.3	N/A
04X2740	Functional Test & Install Protective Coating to Driver Side Door Lock Window Switch	07	0.7	N/A
04X2736	Functional Test & Door Lock & Side Window Switch Replacement (inc. programming)	07	0.5	N/A
	Functional Test & Door Lock & Side Window Switch Replacement (sublet programming) Claim reasonable sublet charges for programming at a GM facility if necessary	07	0.3	Sublet Code "SR"

## OWNER NOTIFICATION

Isuzu will notify customers of this recall on their vehicle (see copy of typical letter included with this bulletin).

## SERVICE FACILITY RECALL RESPONSIBILITY

It is a violation of Federal law for a dealer to deliver a new motor vehicle or any new or used item of motor vehicle equipment (including a tire) covered by this notification under a sale or lease until the defect or noncompliance is remedied.

The US National Traffic and Motor Vehicle Safety Act provides that each vehicle that is subject to a recall of this type must be adequately repaired within a reasonable time after the customer has tendered it for repair. A failure to repair within sixty days after tender of a vehicle is prima facie evidence of failure to repair within a reasonable time. If the condition is not adequately repaired within a reasonable time, the customer may be entitled to an identical or reasonably equivalent vehicle at no charge or to a refund of the purchase price less a reasonable allowance for depreciation. To avoid having to provide these burdensome remedies, every effort must be made to promptly schedule an appointment with each customer and to repair their vehicle as soon as possible. In the recall notification letters, customers are told how to contact the US National Highway Traffic Safety Administration if the recall is not completed within a reasonable time.

Service Facilities are to service all vehicles subject to this recall at no charge to customers, regardless of mileage, age of vehicle, or ownership, from this time forward.

In summary, whenever a vehicle subject to this recall enters your vehicle inventory, or is in your for service in the future, you must take the steps necessary to be sure the recall correction has been made before selling or releasing the vehicle.

## OWNER NOTIFICATION LETTER

# URGENT SAFETY RECALL

Dear Customer:

This notice is sent to you in accordance with the requirements of the National Traffic and Motor Vehicle Safety Act.

Recently, you may have received a letter informing you that your <Year> model year Isuzu Ascender VIN <VIN>, was involved in a Special Policy. The program provided additional coverage for the driver door module if the module ever failed. We have decided to inspect the module to prevent the condition from occurring and have now included your vehicle in Safety Recall 13V-248. Please review the details of the recall below.

The manufacturer of your vehicle, General Motors, has decided that a defect, which relates to motor vehicle safety, exists in certain 2006-2007 model year Isuzu Ascender vehicles.

### WHAT IS THE CONDITION?

If fluid, such as melted snow containing road salt, enters the driver's door module, it may cause corrosion that could result in a short in the circuit board. A short may cause the power door lock and power window switches to function intermittently or stop working. A short may also cause overheating, which could melt components of the door module, producing odor, smoke or a fire. Additionally, the windows may raise or lower themselves, without user input. These conditions may occur even with the vehicle parked and the key removed. It is advised that you park the vehicle outdoors until it has been remedied.

### WHAT WE WILL DO

Your Service Facility will test the driver's window and door lock switches for proper operation. If the switches function properly, your Service Facility will inspect the module, and, if necessary, install a protective coating to the door module. If the switches do not function properly, your Service Facility will install a new door module.

This service will be performed for you at **no charge**. Because of service scheduling requirements, it is likely that your Service Facility will need your vehicle longer than the actual service correction time of approximately 20 minutes to 1 hour and 45 minutes, depending on the repair required.

### WHAT YOU SHOULD DO

Visit our website at [www.isuzu.com](http://www.isuzu.com) to identify the Isuzu Service Facility that is closest to you. Then, you should contact the Service Facility to arrange a service appointment as soon as possible. Please present this letter or refer to Safety Recall No. 13V-248.

If you have any problems obtaining the needed repair or believe that this repair has not been made within a reasonable time, you may contact:

National Owner Relations Department  
Isuzu Motors America, LLC  
1400 S. Douglass Road, Suite 100  
Anaheim, CA 92806

If you still are not satisfied, you may submit a complaint to the Administrator, National Highway Traffic Safety Administration, 1200 New Jersey Avenue, S.E., Washington, D.C. 20590, or call the toll-free Vehicle Safety Hotline at 1-888-327-4236 (TTY: 1-800-424-9153); or go to <http://www.safercar.gov>. The National Highway Traffic Safety Administration Campaign ID number for this recall is 12V-406.

### **REIMBURSEMENT**

If you have already paid for repairs to address the condition covered by this recall, you may be eligible to have those costs reimbursed. The enclosed form explains the terms under which reimbursement may be available and how to request reimbursement. Among other things, you will need to provide the original paid receipt or invoice verifying the repair and the costs of that repair.

If you are a vehicle lessor, Federal law requires that any vehicle lessor receiving this recall notice must forward a copy of this notice to the lessee within ten days.

We regret any inconvenience that this action may cause you.

Sincerely,

ISUZU MOTORS AMERICA, LLC

*Important: If you have sold or traded your Isuzu vehicle, please enter the owner's name and address, if known, on the attached "Change of Information" postcard, tear off at both perforations, and drop it in the mail. Postage has already been paid. We will contact the new owner.*

*Federal law requires that any vehicle lessor receiving this recall notice must forward a copy of this notice to the lessee within ten days. Lessor means a person or entity that is the owner, as reflected on the vehicle title, of any five or more leased vehicles.*