



Campaign Service

BULLETIN

IMPORTANT SERVICE INFORMATION FOR:

- ✓ SERVICE MANAGER
- ✓ SERVICE ADVISOR
- ✓ TECHNICIAN
- ✓ PARTS DEPARTMENT
- ✓ WARRANTY PERSONNEL

BULLETIN NUMBER:
SB13-04-S003A

ISSUE DATE:
AUGUST 2014

GROUP:
ELECTRICAL

SAFETY RECALL 13V-248



LV

DRIVER DOOR SWITCH SHORT CIRCUIT

AFFECTED VEHICLES

- 2006-2007MY Isuzu Ascender Vehicles

The service procedure has been revised. The procedure for applying the protective coating on the door module has been removed. Please discard previous bulletin SB13-04-S003.

SERVICE INFORMATION

CONDITION

The manufacturer of your vehicle, General Motors, has decided that a defect, which relates to motor vehicle safety, exists in certain 2006-2007 Isuzu Ascender vehicles.

If fluid enters the driver's door module, it may cause corrosion that could result in a short in the circuit board. A short may cause the power door lock and power window switches to function intermittently or become inoperative. In rare cases, a short may cause overheating, which could melt components of the door module, producing odor, smoke, or a fire.

CORRECTION

Service Facilities are to inspect the part number of the door module and, if necessary, install a new door module.

VEHICLES INVOLVED

Involved are certain 2006-2007 model year Isuzu Ascender.

Important: Service Facilities are to confirm vehicle eligibility prior to beginning repairs by using the Isuzu Communication System (ICS).

For Service Facilities with involved vehicles, a listing of involved vehicles containing the complete vehicle identification number has been or will be provided. Service Facilities will not have a report available if they have no involved vehicles currently assigned.

SERVICE PROCEDURE

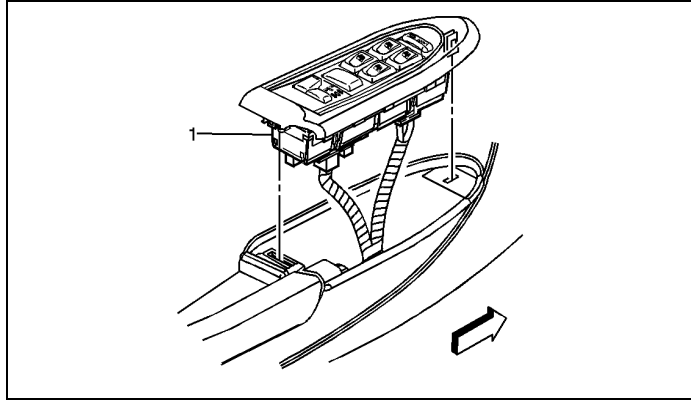

Figure 1 – Driver Side Door Lock & Side Window Switch

1. Remove the driver side door lock and side window switch. Refer to *Door Lock and Side Window Switch Replacement - Driver Side* in the service manual.

Part Number	Description
25866992	SWITCH, DR LK & SI WDO
25866993	SWITCH, DR LK & SI WDO
25866994	SWITCH, DR LK & SI WDO
25866996	SWITCH, DR LK & SI WDO

2. Determine the part number on the driver side door lock and side window switch. The part number is on the side of the switch on the label.
 - a) If the part number on the switch is listed in the parts table above, no repair is required. Re-install the driver side door lock and side window switch. Refer to *Door Lock and Side Window Switch Replacement – Driver Side* in the service manual, and then proceed to Step 3, “Applying the Campaign Label”.
 - b) If the part number on the switch is NOT listed on the table above, replace the driver side door lock and side window switch. Refer to *Door Lock and Side Window Switch Replacement – Driver Side* in the service manual.
3. Applying the Campaign Label
 - a) Using a ball-point pen, fill in a campaign label (P/N 2-90028-700-0) with Campaign Number 13V-248, Isuzu service facility code and repair date.
 - b) Affix the campaign label onto the driver's side B-pillar.

ISUZU

CAMPAIGN NUMBER

DEALER CODE: _____

REPAIR DATE: _____

P/N 2-90028-700-0

CLAIM INFORMATION

Refer to the Isuzu ICS Claims Processing Manual for details on Campaign Claim Submission.

Submit only **one** claim with the applicable Labor Code as indicated below.

Labor Code	Description	Trouble Code	Labor Time	Net Item
04X2739	Functional Test & Verify Part Number – No Further Action Req'd	07	0.3	N/A
04X2736	Functional Test & Door Lock & Side Window Switch Replacement (inc. programming)	07	0.5	N/A
	Functional Test & Door Lock & Side Window Switch Replacement (sublet programming) Claim reasonable sublet charges for programming at a GM facility if necessary	07	0.3	Sublet Code "SR"

OWNER NOTIFICATION

Isuzu will notify customers of the revised service procedure involved in this recall in the near future.

SERVICE FACILITY RECALL RESPONSIBILITY

It is a violation of Federal law for a dealer to deliver a new motor vehicle or any new or used item of motor vehicle equipment (including a tire) covered by this notification under a sale or lease until the defect or noncompliance is remedied.

The US National Traffic and Motor Vehicle Safety Act provides that each vehicle that is subject to a recall of this type must be adequately repaired within a reasonable time after the customer has tendered it for repair. A failure to repair within sixty days after tender of a vehicle is prima facie evidence of failure to repair within a reasonable time. If the condition is not adequately repaired within a reasonable time, the customer may be entitled to an identical or reasonably equivalent vehicle at no charge or to a refund of the purchase price less a reasonable allowance for depreciation. To avoid having to provide these burdensome remedies, every effort must be made to promptly schedule an appointment with each customer and to repair their vehicle as soon as possible. In the recall notification letters, customers are told how to contact the US National Highway Traffic Safety Administration if the recall is not completed within a reasonable time.

Service Facilities are to service all vehicles subject to this recall at no charge to customers, regardless of mileage, age of vehicle, or ownership, from this time forward.

In summary, whenever a vehicle subject to this recall enters your vehicle inventory, or is in your for service in the future, you must take the steps necessary to be sure the recall correction has been made before selling or releasing the vehicle.