

TMS-NTC-13122
May 30, 2013

Recall Management Division
National Highway Traffic Safety Administration
1200 New Jersey Avenue, SE
Washington, DC 20590

Re: Toyota Safety Recall 13V-163 – Dealer Notification Remedy

To whom it may concern,

Please find attached the Dealer Notification - Remedy Letter for Toyota Safety Recall 13V-163 on the following Toyota vehicles:

- 2007 to 2013 Model Year FJ Cruiser

If you have any questions regarding this matter, please contact me at (310) 468-5316.

Sincerely,

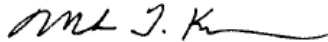

Quality Compliance Assistant Manager

Attachments:

- Toyota 13V-163 (D0G) Dealer Notification (Remedy)

TOYOTA

Toyota Motor Sales, U.S.A., Inc.
19001 South Western Avenue
Torrance, CA 90501
(310) 468-4000

To: All Toyota Dealer Principals, Service Managers, Parts Managers

Subject: Safety (Non-Compliance) Recall D0G – **Remedy Notification**
Genuine Toyota Auxiliary Light Kit Accessory
Designed to fit 2007 to 2013 Model Year FJ Cruiser Vehicles

As previously announced, in April 2013, Toyota filed a Noncompliance Information Report (NCIR) with the National Highway Traffic Safety Administration (NHTSA) informing the agency that certain 2007 to 2013 Model Year FJ Cruiser vehicles equipped with the Genuine Toyota Auxiliary Light Kit accessory fail to conform to a provision of Federal Motor Vehicle Safety Standard (FMVSS) 108. There are approximately 11,500 Genuine Toyota Auxiliary Light Kits which were installed at vehicle processing centers, by dealers, or sold over the counter.

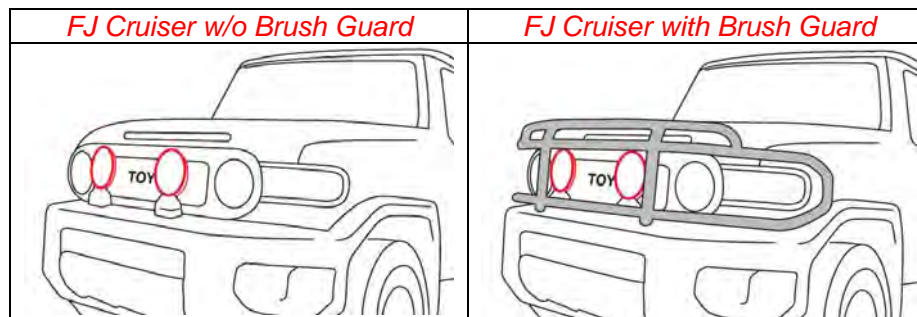

Toyota has completed remedy preparation and will begin to notify owners.

Background

The subject Genuine Toyota Auxiliary Light Kit is specifically designed for 2007 to 2013 Model Year FJ Cruiser vehicles. The Auxiliary Light Kit consists of two 6-inch 55 Watt lights which are mounted on the front bumper inboard of the headlamp assemblies. The Auxiliary Light Kit can be illuminated when the driver activates the vehicle's high beam lights. The illumination of the Auxiliary Light Kit with the vehicle's high beams causes the vehicle to exceed one of the allowable lighting thresholds specified in FMVSS 108. Light intensities above the maximum allowable limit could cause increased glare for oncoming traffic and increase the risk of a crash.

Remedy

If the vehicle is equipped with a Genuine Toyota Auxiliary Light Kit any authorized Toyota dealer will replace the Auxiliary Light Brackets and Bulbs at **NO CHARGE** to the vehicle owner.

The following information is provided to inform you and your dealers of this campaign and your degree of involvement.

1. Owner Notification Mailing Date

The owner notification will commence in late May, 2013.

There are approximately 11,500 Genuine Toyota Auxiliary Light Kits which were installed at vehicle processing centers, by dealers, or sold over the counter. In order to identify all the vehicles which may have the Genuine Toyota Auxiliary Light Kit installed Toyota will be mailing owner notices to all owners of 2007 to 2013 model year FJ Cruiser vehicles; this mailing will include approximately 209,000 letters.

If the vehicle does **NOT** have the Genuine Toyota Auxiliary Light Kit, it is **NOT** involved in this Safety Recall.

(Owner Notification Mailing Date Continued. . .)

Please note that only owners of the covered vehicles will be notified. If a dealer is contacted by an owner who has not yet received the notification, please **verify coverage by confirming through Dealer Daily/TIS**. Dealers should perform the procedure as outlined in the Technical Instructions located on TIS.

Toyota tries very hard to obtain current customer name and address information when mailing owner letters. In the event your dealership receives a notice for a vehicle that was sold prior to the Safety Recall announcement, it is the dealerships responsibility to forward the owner letter to the customer who purchased the vehicle.

2. New Vehicles in Dealer Stock

As required by Federal law (49 Code of Federal Regulations §577.13), Toyota is advising that dealers are not to deliver any new vehicles in their inventory equipped with the Genuine Toyota Auxiliary Light Kit Accessory involved in this Safety (Non-Compliance) Recall unless the non-compliance has been remedied. Any Genuine Toyota Auxiliary Light Kits currently in dealer inventory must also not be sold. Vehicle Safety Recall completion can be verified through TIS.

3. Pre-Owned Vehicles in Dealer Stock

Toyota requests that dealers verify whether their Pre-Owned vehicles in dealer inventory are covered by this Safety Recall. If a vehicle is covered the dealer should perform the Safety Recall remedy prior to customer delivery.

4. Dealer Summary Reports

Summary Reports, containing the number of covered vehicles in your dealership’s primary marketing area, have been enclosed in the dealer package. Please note the numbers of vehicles shown indicates PPO sales as well as over-the-counter sales of the Genuine Toyota Auxiliary Light Kit. (Please verify eligibility by confirming through Dealer Daily or TIS prior to performing repairs.)

5. Number and Identification of Covered Vehicles

There are approximately 11,500 Genuine Toyota Auxiliary Light Kits which were installed at vehicle processing centers, by dealers, or sold over the counter for 2007 to 2013 model year FJ Cruiser vehicles

To ensure over the counter customers are notified approximately 209,000 (2007 to 2013MY) FJ Cruiser owners will receive a notification in the U.S. All 2007 to 2013 MY FJ Cruiser Vehicles will be identified under Safety Recall campaign code D0G.

| WMI | MY | VDS | START | FINISH |
|-----|------|-------|---------|---------|
| JTE | 2007 | BU11F | 0001027 | 0101420 |
| | | ZU11F | 0001015 | 0019076 |
| | 2008 | BU11F | 0101421 | 0107257 |
| | | BU11F | K001003 | K056845 |
| | | ZU11F | 0019077 | 0019919 |
| | 2009 | ZU11F | K001001 | K007996 |
| | | BU11F | K056849 | K070006 |
| | | ZU11F | K007997 | K008509 |
| | 2010 | BU4BF | K070007 | K099142 |
| | | ZU4BF | K008510 | K010844 |
| | 2011 | BU4BF | K092698 | K116292 |
| | | ZU4BF | K010845 | K011727 |
| | 2012 | BU4BF | K115382 | K148760 |
| | | ZU4BF | K011728 | K012746 |
| | 2013 | BU4BF | K148761 | K166714 |
| | | ZU4BF | K012747 | K013341 |

(Number and Identification of Covered Vehicles Continued. . .)

If your dealership is contacted by an owner who has not yet received the notification, please **verify coverage by confirming through Dealer Daily/TIS**. Dealers should perform the procedure as outlined in the Technical Instructions located on TIS.

A UIO matrix by state is provided to inform your dealership of the number of specific PPO equipped or parts sales in your state. Please note the following state breakdown is representative of PPO vehicles only.

| STATE | UIO | STATE | UIO | STATE | UIO | STATE | UIO | STATE | UIO |
|-------|-----|-------|-----|-------|-----|-------|-----|--------|-------|
| AK | 33 | HI | 11 | MI | 161 | NV | 99 | UT | 126 |
| AL | 47 | IA | 54 | MN | 58 | NY | 292 | VA | 154 |
| AR | 68 | ID | 56 | MO | 129 | OH | 140 | VT | 17 |
| AZ | 271 | IL | 228 | MS | 74 | OK | 161 | WA | 202 |
| CA | 988 | IN | 70 | MT | 28 | OR | 146 | WI | 63 |
| CO | 331 | KS | 80 | NC | 97 | PA | 238 | WV | 48 |
| CT | 58 | KY | 63 | ND | 8 | RI | 13 | WY | 28 |
| DC | 13 | LA | 106 | NE | 31 | SC | 33 | | |
| DE | 17 | MA | 128 | NH | 54 | SD | 11 | Total: | 6,872 |
| FL | 318 | MD | 108 | NJ | 154 | TN | 114 | | |
| GA | 82 | ME | 42 | NM | 116 | TX | 905 | | |

6. Remedy Procedures

For repair information please refer to the Technical Instructions found on TIS.

Conduct all applicable, non-completed Safety Recall and Service Campaigns on the vehicle during the time of appointment.

7. Parts Ordering Process (Manual Allocation Control)

Only 11,500 vehicles equipped with a Genuine Toyota Auxiliary Light Kit will require the following parts. To ensure parts availability the parts have been placed on Manual Allocation Control (MAC). If you require a part that has been placed on MAC, please send an email to Quality_Compliance@Toyota.com with the following information:

- **Subject Line: D0G MAC Release Request (Dealer Code)**
- **Dealer Code**
- **VIN Number**
- **Part Number and Qty. Ordered**
- **Order Reference Number**
- **Order Date**
- **Contact Person**

Once a representative confirms the information provided, the part will be released. If there is a concern regarding the information provided, a representative will contact your dealership. Please allow 2-3 days for part release after providing the requested information.

Important Notes:

- **Once you have placed your order DO NOT upgrade or change your order status.**
- **Failure to provide the above information within 48 hours will result in an order cancellation.**

| Model Application | Part No. | Part Name | Qty/Unit |
|---|-------------|--|----------|
| FJ Cruiser equipped with Genuine Toyota Auxiliary Light Kit | PT591-35140 | Auxiliary Light Kit* | 1 |
| | PT591-35145 | Auxiliary Light Kit for vehicle with Brush Guard | 1 |

Parts Ordering Process continued...

IMPORTANT PARTS ORDERING UPDATE

All Safety Recall, Service Campaign (SSC/LSC) and Customer Support Program (CSP) parts are eligible for the Monthly Parts Return Program. Please refer to PANT Bulletin 2011-087 for campaign parts that are currently returnable under the Monthly Parts Return Program and additional details.

8. Mandatory Part Return Process (Dealer Inventory)

Dealerships are required to return all FJ cruiser Genuine Toyota Auxiliary Light Kits and related service parts, including special customer orders that have not yet been installed, to their facing PDC.

The part numbers affected by this **mandatory** return are:

- PT297-35061: Auxiliary Driving Lights
- PT297-35062: Bracket Kit
- PT297-35070-LB: Left Side Replacement Bracket
- PT297-35070-RB: Right Side Replacement Bracket
- PT297-35070-LP: Replacement Lamp Assy. with Bulb

Please refer to PANT bulletin 2013-024 for detailed return instructions.

9. Warranty Processor Instructions

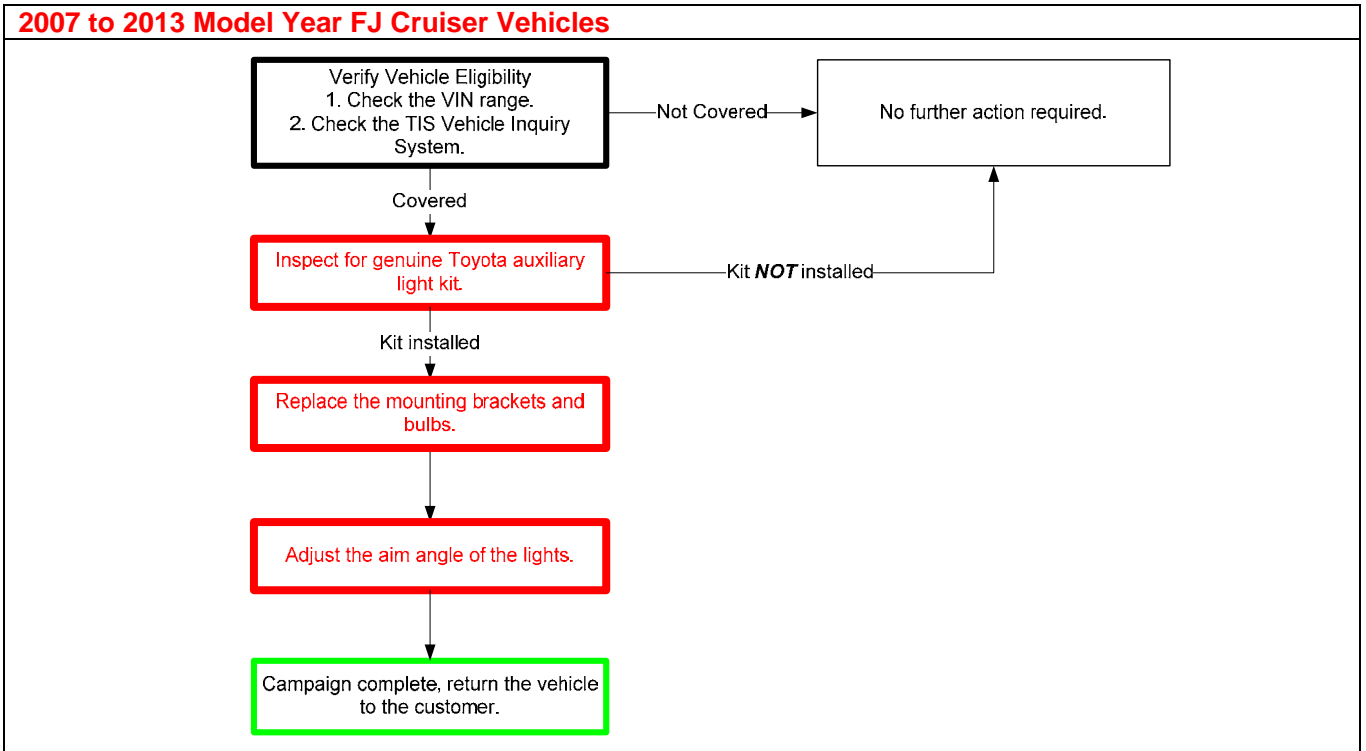

| Safety Recall | Op. Code | Description | Flat Rate Hour |
|---------------|----------|---|----------------|
| D0G | TBD | Not Equipped with Genuine Toyota Auxiliary Light Kit – Close Campaign | XX hr/vehicle |
| | TBD | Replace Auxiliary Light Brackets and Bulbs | XX hr/vehicle |
| | TBD | Replace Auxiliary Light Brackets and Bulbs on Brush Guard Vehicle | XX hr/vehicle |

- The flat rate times include 0.1 hours for administrative cost per unit for the dealership for Op. Code

Operation codes will be provided in the near future, thank you for your patience.

Campaign Designation Decoder

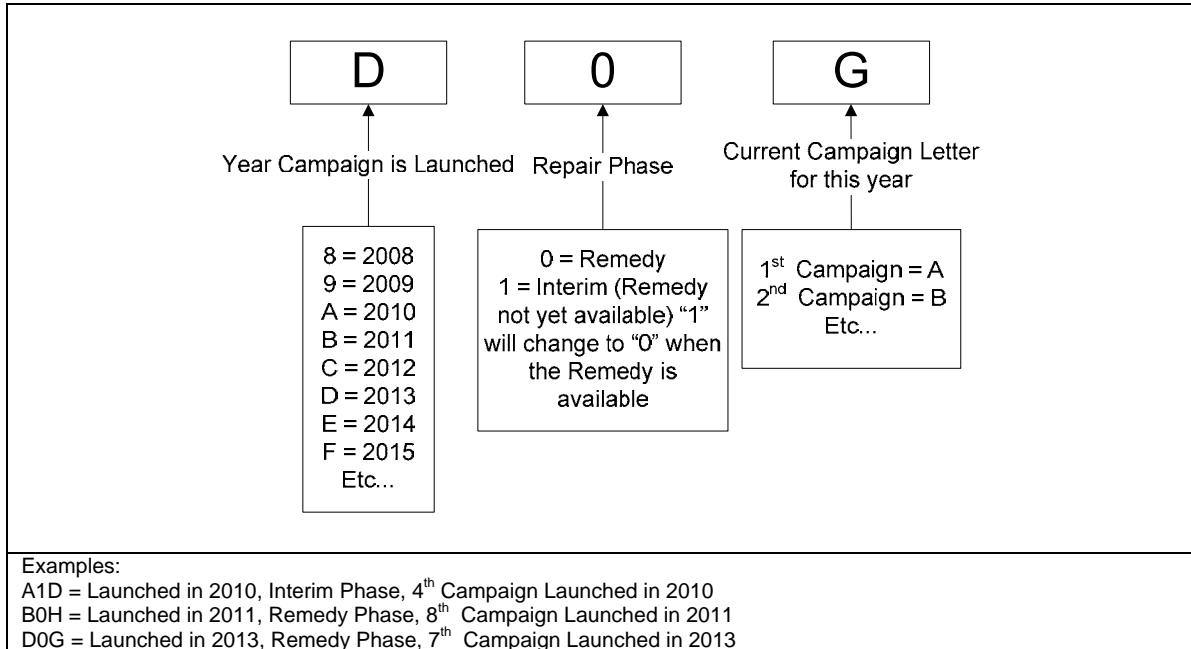

10. Repair Quality Confirmation

The repair quality of covered vehicles is extremely important to Toyota. To help ensure that all vehicles have the repair performed correctly, please designate at least one associate (someone other than the individual who performed the repair) to verify the repair quality of every vehicle prior to customer delivery.

11. Media Contacts

If you are a dealership associate and have any questions, please contact your District Service/Parts Manager. ***In the event you are contacted by the News media***, it is imperative that all media contacts (local and national) receive a consistent message. In this regard, all media contacts must be directed to Cindy Knight (310) 468-2170 in Toyota Corporate Communications. (Please do not provide this number to customers. Please provide this contact to only media associates.)

12. Customer Contacts

A FAQ is attached to help respond to any customer concerns. If the customer has any further questions, they are requested to contact the Toyota Customer Experience Center. The Toyota Customer Experience Center can be reached at 1-888-270-9371 Monday through Friday, 5:00 am to 6:00 pm, or Saturday 7:00 am through 4:00 pm Pacific Time.

Please note the attached FAQ is published on the www.Toyota.com website for customer viewing. Toyota will be publishing future Safety Recall FAQs on the Toyota.com website to assist customers.

Please review this entire package with your Service and Parts staff to familiarize them with the proper step-by-step procedures required to implement this Safety Recall.

Thank you for your cooperation.

TOYOTA MOTOR SALES, U.S.A., INC.



Safety (Non-Compliance) Recall D0G (D1G) – Remedy Notice
Genuine Toyota Auxiliary Light Kit Accessory
Designed to fit 2007 to 2013 Model Year FJ Cruiser Vehicles

Customer Frequently Asked Questions

Published late May, 2013

We are providing the following information to keep you informed of the recall details.

Background

As previously announced, in April 2013, Toyota filed a Non-Compliance Information Report (NCIR) with the National Highway Traffic Safety Administration (NHTSA) informing the agency that 2007 to 2013 Model Year FJ Cruiser vehicles equipped with the Genuine Toyota Auxiliary Light Kit accessory kit fail to conform to a provision of Federal Motor Vehicle Safety Standard (FMVSS) 108. There are approximately 11,500 Genuine Toyota Auxiliary Light Kits which were installed at vehicle processing centers, by dealers, or sold over the counter.

Q1: What is the condition?

A1: The subject Genuine Toyota Auxiliary Light Kit is specifically designed for 2007 to 2013 Model Year FJ Cruiser vehicles. The Auxiliary Light Kit consists of two 6-inch 55 Watt lights which are mounted on the front bumper inboard of the headlamp assemblies. The Auxiliary Light Kit can be illuminated when the driver activates the vehicle's high beam lights. The illumination of the Auxiliary Light Kit with the vehicle's high beams causes the vehicle to exceed one of the allowable lighting thresholds specified in FMVSS 108. Light intensities above the maximum allowable limit could cause increased glare for oncoming traffic and increase the risk of a crash.

Q1a: What is the Genuine Toyota Auxiliary Light Kit?

A1a: The Genuine Toyota Auxiliary Light Kit is an optional Toyota accessory which consists of two bumper or brush guard mounted 6-inch round lights and two FJ branded covers to protect the lights when not in use. Please refer to the following images for reference.

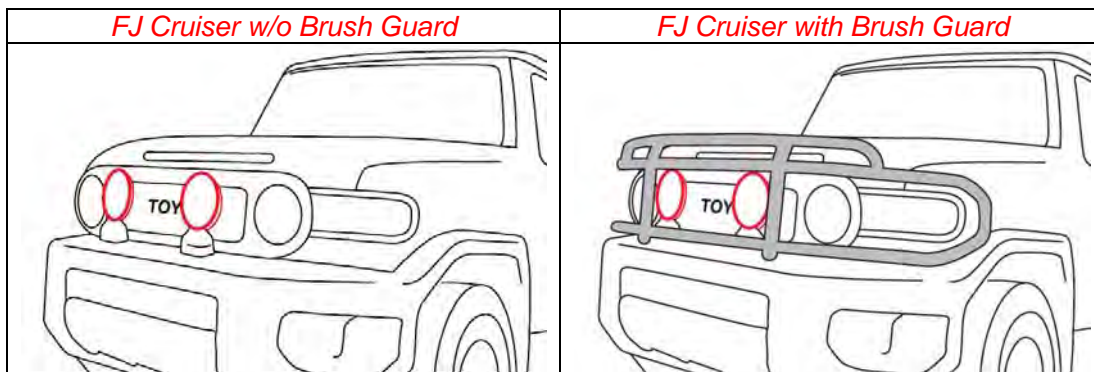

Q2: How many Genuine Toyota Auxiliary Light Kits are covered by this Safety (Non-Compliance) Recall?

A2: There are approximately 11,500 Genuine Toyota Auxiliary Light Kits which were installed at vehicle processing centers, by dealers, or sold over the counter for 2007 to 2013 Model Year FJ Cruiser Vehicles.

Q2a: Are there any other Toyota or Lexus vehicles covered?

A2a: No. The Genuine Toyota Auxiliary Light Kit was designed only for use on 2007 to 2013 FJ Cruiser models.

Q2b: Which and how many vehicles are covered by this Safety Recall?

A2b: There are approximately 11,500 vehicles that could have the Genuine Toyota Auxiliary Light Kit accessory installed. To ensure that dealer installations and over-the-counter accessory sales customers are notified, approximately 209,000 letters will be mailed to all 2007 through certain 2013 Model Year FJ Cruiser owners.

Q3: What is Toyota going to do?

A3: If the vehicle is equipped with a Genuine Toyota Auxiliary Light Kit, any authorized Toyota dealer will replace the Auxiliary Light Brackets and Bulbs at **NO CHARGE** to the vehicle owner. Only vehicles equipped with a Genuine Toyota Auxiliary Light Kit will require repair.

Q3a: How and when will Toyota notify owner of vehicles covered by this Safety (Non-Compliance) Recall?

A3a: The owner notification is anticipated to start in late May, 2013.

There are approximately 11,500 Genuine Toyota Auxiliary Light Kits which were installed at vehicle processing centers, by dealers, or sold over the counter. In order to identify all the vehicles which may have the Genuine Toyota Auxiliary Light Kit installed Toyota will be mailing owner notices to all owners of 2007 to 2013 model year FJ Cruiser vehicles; this mailing will include approximately 209,000 letters.

If the vehicle does **NOT** have the Genuine Toyota Auxiliary Light Kit, it is **NOT** involved in this Safety Recall.

Q3b: How does Toyota obtain my mailing information?

A3b: Toyota uses an industry provider who works with each state Department of Motor Vehicles (DMV) to receive registration or title information. Please make sure your registration or title information is correct.

Q3c: Do I need my owner letter to have the remedy performed?

A3c: You do not need an owner letter to have this recall completed; however, to assist the dealer in confirming vehicle eligibility, we request that you present the owner notification at the time of your service appointment.

Q4: Can I inspect my vehicle to determine if it has the Genuine Toyota Auxiliary Light Kit?

A4: Yes, you can reference the images shown below to determine if your vehicle is equipped with the optional Genuine Toyota Auxiliary Light Kit accessory.

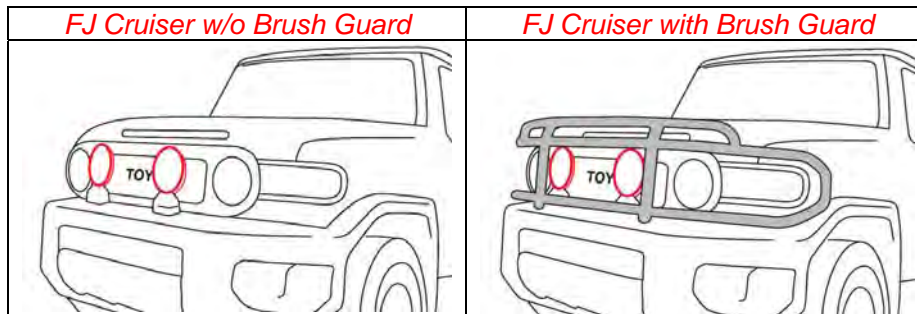

If so equipped, please contact your local authorized Toyota dealer as soon as possible to schedule an appointment to have the remedy performed.

If the vehicle does **NOT** have the Genuine Toyota Auxiliary Light Kit, it is **NOT** involved in this Safety Recall and no additional action is necessary.

Q4a: What if I am not comfortable performing the inspection?

A4a: Any authorized Toyota dealer will be more than happy to perform an inspection at **no charge** to you to determine if your vehicle is covered by this safety recall.

Q5: How long will the repair take?

A5: If your vehicle is equipped with a Genuine Toyota Auxiliary Light Kit accessory, the repair will take approximately 2 hours. However, depending upon the dealer's work schedule, it may be necessary to make the vehicle available for a longer period of time.

Q6: What if I previously paid for repairs to my vehicle for this condition?

A6: Please refer to the remedy owner letter for instructions to request reimbursement for previous repair costs. Please note that the dealer must complete the Safety Recall remedy before reimbursement consideration requests can be processed.

Q7: What if an owner has additional questions or concerns?

A7: If you have additional questions or concerns please contact the Toyota Customer Experience Center at 1-888-270-9371 Monday through Friday, 5:00 am to 6:00 pm, or Saturday 7:00 am through 4:00 pm Pacific Time.

Genuine Toyota Auxiliary Light Kit Accessory
Designed to fit 2007 to 2013 Model Year FJ Cruiser Vehicles
SAFETY RECALL NOTICE

[VIN]

Dear Toyota Customer:

URGENT SAFETY RECALL
This is an important Safety Recall.
If necessary, the remedy will be performed at **NO CHARGE** to you.

This notice is being sent to you in accordance with the requirements of the National Traffic and Motor Vehicle Safety Act. Toyota has decided that 2007 to 2013 Model Year FJ Cruiser vehicles equipped with a Genuine Toyota Auxiliary Light Kit Accessory fail to conform to Federal Motor Vehicle Safety Standard No. 108, Lamps, reflective devices, and associated equipment. **We are sending you this notice in the event your vehicle is equipped with this accessory.**

What is the condition?

The subject Genuine Toyota Auxiliary Light Kit is specifically designed for 2007 to 2013 Model Year FJ Cruiser vehicles. The Auxiliary Light Kit consists of two 6-inch 55 Watt lights which are mounted on the front bumper inboard of the headlamp assemblies. The Auxiliary Light Kit can be illuminated when the driver activates the vehicle's high beam lights. The illumination of the Auxiliary Light Kit with the vehicle's high beams causes the vehicle to exceed one of the allowable lighting thresholds specified in FMVSS 108. Light intensities above the maximum allowable limit could cause increased glare for oncoming traffic and increase the risk of a crash.

What should you do?

You can inspect your vehicle referencing the images below to determine if it is equipped with an optional Genuine Toyota Auxiliary Light Kit accessory.

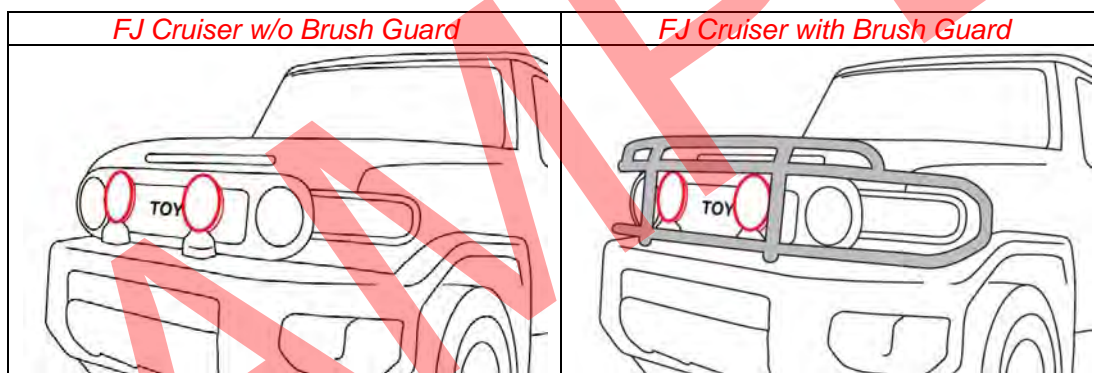

If your vehicle is equipped with a Genuine Toyota Auxiliary Light Kit shown above, please contact your local authorized Toyota dealer to make an appointment to have the remedy performed at **no charge** to you.

If your vehicle does **NOT** have the optional Genuine Toyota Auxiliary Light Kit, it is **NOT** involved in this Safety Recall and no additional action is necessary.

If you are not comfortable doing this inspection yourself, any authorized Toyota dealer will perform the inspection at **no charge**.

You do not need an owner letter to have this recall completed; however, to assist the dealer in confirming vehicle eligibility, we request that you present this notice at the time of your service appointment.

If you would like to update your vehicle ownership or contact information, you may do so by registering at www.toyota.com/ownersupdate. You will need your full 17-digit Vehicle Identification Number (VIN) to input the new information.

What will Toyota do?

If your vehicle is equipped with an optional Genuine Toyota Auxiliary Light Kit, any authorized Toyota dealer will replace the Auxiliary Light Brackets and Bulbs at **no charge** to you. The repair will take approximately 2 hours. However, depending upon the dealer's work schedule, it may be necessary to make your vehicle available for a longer period of time

What if you have other questions?

- ***Your local Toyota dealer will be more than happy to answer any of your questions and set up an appointment to perform the repair.***
- You can find additional information and locate a Toyota dealer in your area by going online and visiting www.toyota.com/recall.
- If you require further assistance, you may contact the Toyota Customer Experience Center at 1-888-270-9371 Monday through Friday, 5:00 am to 6:00 pm, Saturday 7:00 am through 4:00 pm Pacific Time.

If you believe that the dealer or Toyota has failed or is unable to remedy the defect within a reasonable time, you may submit a complaint to the Administrator, National Highway Traffic Safety Administration, 1200 New Jersey Avenue S.E., Washington, D.C. 20590, or call the toll free Vehicle Safety Hot Line at 1-888-327-4236 (TTY: 1-800-424-9153), or go to <http://www.safercar.gov>.

What if you have previously paid for repairs to your vehicle for this specific condition?

If you have previously paid for repair to your vehicle for this specific condition prior to receiving this letter, please mail a copy of your repair order, proof-of-payment and proof-of-ownership to the following address for reimbursement consideration:

Toyota Motor Sales, U.S.A., Inc
Toyota Customer Experience, WC 10
19001 South Western Avenue
Torrance, CA 90509

Please note that the dealer must complete the Safety Recall remedy before reimbursement consideration requests can be processed.

If you are a vehicle lessor, Federal law requires that any vehicle lessor receiving this recall notice must forward a copy of this notice to the lessee within ten days.

We have sent this notice in the interest of your continued satisfaction with our products, and we sincerely regret any inconvenience this condition may have caused you.

Thank you for driving a Toyota.

Sincerely,

TOYOTA MOTOR SALES, U.S.A., INC.

**Genuine Toyota Auxiliary Light Kit Accessory
Designed to fit 2007 to 2013 Model Year FJ Cruiser Vehicles**

SAFETY RECALL NOTICE

[VIN]

Dear Toyota Customer:

URGENT SAFETY RECALL
This is an important Safety Recall.
The remedy will be performed at **NO CHARGE** to you.

This notice is being sent to you in accordance with the requirements of the National Traffic and Motor Vehicle Safety Act. Toyota has decided that 2007 to 2013 Model Year FJ Cruiser vehicles equipped with a Genuine Toyota Auxiliary Light Kit Accessory fail to conform to Federal Motor Vehicle Safety Standard No. 108, Lamps, reflective devices, and associated equipment. ***Our records indicate your vehicle was equipped with this accessory at first vehicle delivery.***

What is the condition?

The subject Genuine Toyota Auxiliary Light Kit is specifically designed for 2007 to 2013 Model Year FJ Cruiser vehicles. The Auxiliary Light Kit consists of two 6-inch 55 Watt lights which are mounted on the front bumper inboard of the headlamp assemblies. The Auxiliary Light Kit can be illuminated when the driver activates the vehicle's high beam lights. The illumination of the Auxiliary Light Kit with the vehicle's high beams causes the vehicle to exceed one of the allowable lighting thresholds specified in FMVSS 108. Light intensities above the maximum allowable limit could cause increased glare for oncoming traffic and increase the risk of a crash.

What will Toyota do?

Any authorized Toyota dealer will replace the Auxiliary Light Brackets and Bulbs at **NO CHARGE** to you.

What should you do?

This is an important Safety Recall

Please contact, any authorized Toyota dealer and make an appointment to have the Safety Recall remedy performed.

Replacement of the Auxiliary Light Brackets and Bulbs will take approximately 2 hours. However, depending upon the dealer's work schedule, it may be necessary to make your vehicle available for a longer period of time.

You do not need an owner letter to have this recall completed; however, to assist the dealer in confirming vehicle eligibility, we request that you present this notice at the time of your service appointment.

If you would like to update your vehicle ownership or contact information, you may do so by registering at www.toyota.com/ownersupdate. You will need your full 17-digit Vehicle Identification Number (VIN) to input the new information.

What if you have other questions?

- ***Your local Toyota dealer will be more than happy to answer any of your questions and set up an appointment to perform the repair.***
- You can find additional information and locate a Toyota dealer in your area by going online and visiting www.toyota.com/recall.
- If you require further assistance, you may contact the Toyota Customer Experience Center at 1-888-270-9371 Monday through Friday, 5:00 am to 6:00 pm, Saturday 7:00 am through 4:00 pm Pacific Time.

If you believe that the dealer or Toyota has failed or is unable to remedy the defect within a reasonable time, you may submit a complaint to the Administrator, National Highway Traffic Safety Administration, 1200 New Jersey Avenue S.E., Washington, D.C. 20590, or call the toll free Vehicle Safety Hot Line at 1-888-327-4236 (TTY: 1-800-424-9153), or go to <http://www.safercar.gov>.

What if you have previously paid for repairs to your vehicle for this specific condition?

If you have previously paid for repair to your vehicle for this specific condition prior to receiving this letter, please mail a copy of your repair order, proof-of-payment and proof-of-ownership to the following address for reimbursement consideration:

Toyota Motor Sales, U.S.A., Inc
Toyota Customer Experience, WC 10
19001 South Western Avenue
Torrance, CA 90509

Please note that the dealer must complete the Safety Recall remedy before reimbursement consideration requests can be processed.

If you are a vehicle lessor, Federal law requires that any vehicle lessor receiving this recall notice must forward a copy of this notice to the lessee within ten days.

We have sent this notice in the interest of your continued satisfaction with our products, and we sincerely regret any inconvenience this condition may have caused you.

Thank you for driving a Toyota.

Sincerely,

TOYOTA MOTOR SALES, U.S.A., INC.

SAMPLE

TECHNICAL INSTRUCTIONS
FOR
SAFETY (NON-COMPLIANCE) RECALL D0G
GENUINE TOYOTA AUXILIARY LIGHT KIT ACCESSORY
DESIGNED TO FIT 20071 – 2013 MODEL YEAR FJ CRUISER
WITH BRUSHGUARD

I. OPERATION FLOW CHART

The flow chart is for reference only. **DO NOT** use it in place of the full technical instructions. Follow **ALL** steps as outlined in the full technical instructions to confirm the campaign is completed correctly.

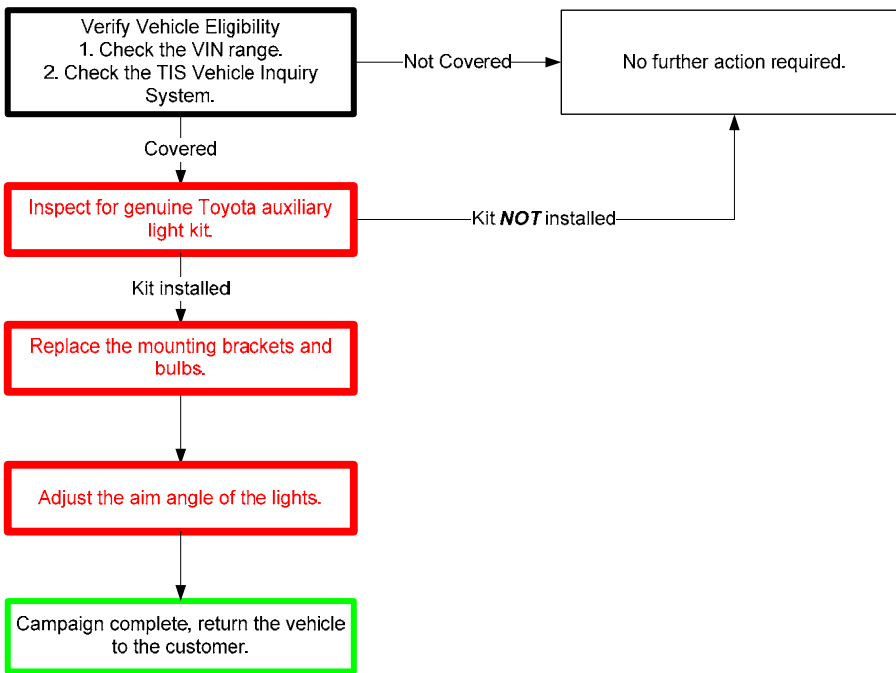

II. IDENTIFICATION OF AFFECTED VEHICLES

A. COVERED VIN RANGE

| WMI | Year | VIN Range | | |
|-----|------|-----------|-----------------|-----------------|
| | | VDS | Range | |
| JTE | 2007 | BU11F | 0001027-0101420 | |
| | | ZU11F | 0001015-0019076 | |
| | 2008 | BU11F | | 0101421-0107257 |
| | | | | K001003-K056845 |
| | | ZU11F | | 0019077-0019919 |
| | | | | K001001-K007996 |
| | 2009 | BU11F | K056849-K070006 | |
| | | ZU11F | K007997-K008509 | |
| | 2010 | BU4BF | K070007-K099142 | |
| | | ZU4BF | K008510-K010844 | |
| | 2011 | BU4BF | K092698-K116292 | |
| | | ZU4BF | K010845-K011727 | |
| | 2012 | BU4BF | K115382-K148760 | |
| | | ZU4BF | K011728-K012746 | |
| | 2013 | BU4BF | K148761-K166714 | |
| | | ZU4BF | K012747-K013341 | |

NOTE:

- Check the TIS Vehicle Inquiry System to confirm the VIN is involved in this Safety (Non-Compliance) Recall, and that the campaign has not already been completed prior to dealer shipment or by another dealer.
- TMS warranty will not reimburse dealers for repairs conducted on vehicles that are not affected or were completed by another dealer.

III. PREPARATION

A. PARTS

| Part Number | Part Description | Quantity |
|--|------------------------------------|----------|
| PT591-35145 | Auxiliary Light Kit, Bumper Mount* | 1 |
| *The kit above includes the following parts. | | |
| PT297-35140 | H3 Bulb, 35W, Hella | 2 |
| - | M8x20 Flange Head Bolt | 2 |
| PT591-35146-UP | Upper Brushguard Mounting Bracket | 2 |
| PT591-35146-LW | Lower Brushguard Mounting Bracket | 2 |

B. TOOLS & EQUIPMENT

- Standard hand tools
- Torque wrench
- Masking tape

IV. BACKGROUND

The subject Genuine Toyota Auxiliary Light Kit is specifically designed for 2007 to 2013 Model Year FJ Cruiser vehicles. The Auxiliary Light Kit consists of two 6-inch 55 Watt lights which are mounted on the front bumper inboard of the headlamp assemblies. The Auxiliary Light Kit can be illuminated when the driver activates the vehicle's high beam lights. The illumination of the Auxiliary Light Kit with the vehicle's high beams causes the vehicle to exceed one of the allowable lighting thresholds specified in FMVSS 108.

With brush guard

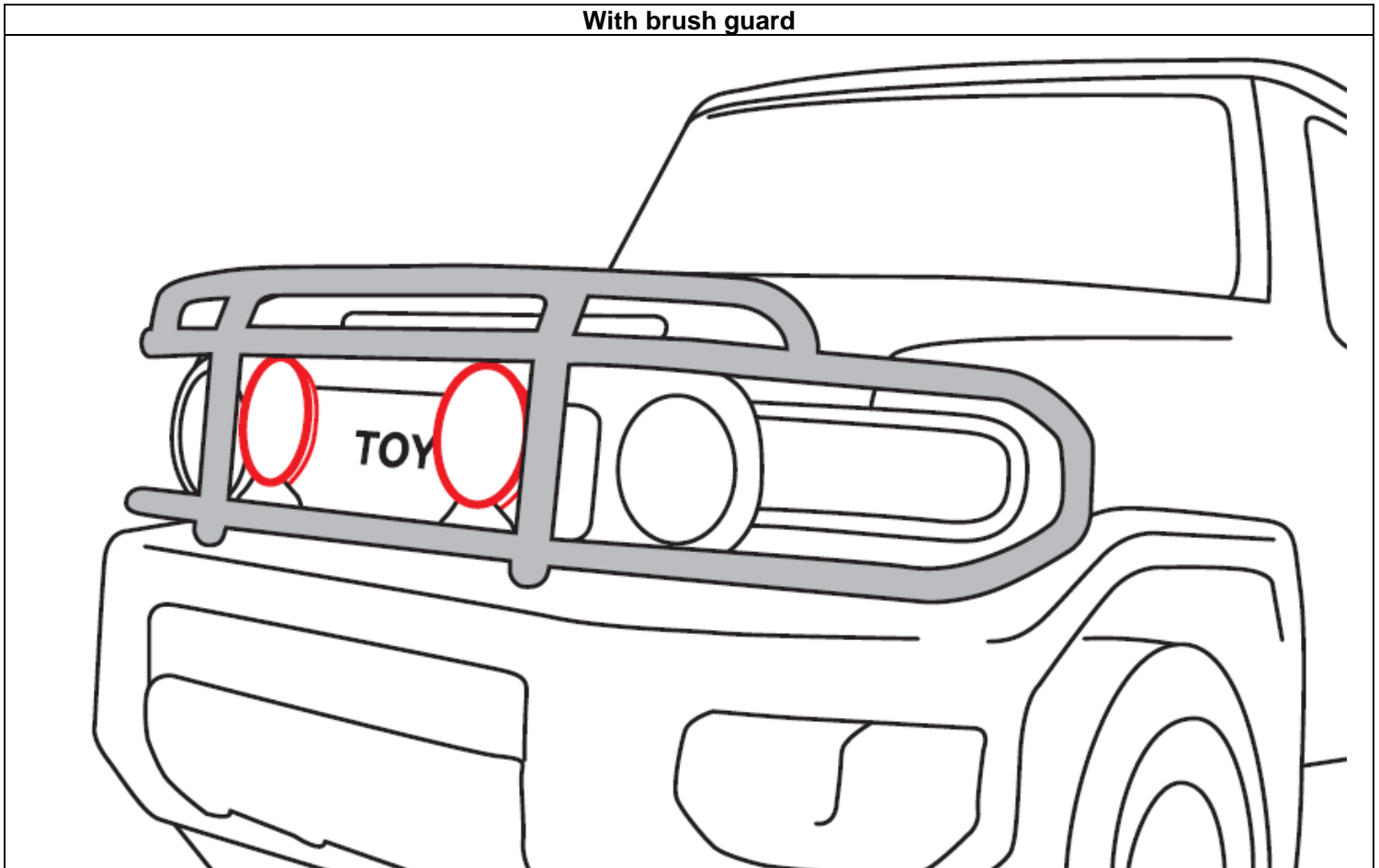

V. AUXILIARY LIGHT INSPECTION

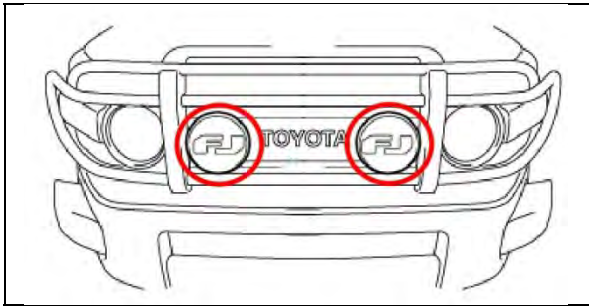

1. INSPECT FOR TOYOTA GENUINE AUXILIARY LIGHTS

- a) Visually inspect the vehicle to determine if it is equipped with the genuine Toyota auxiliary light kit accessory.

| CONDITION 1 | ACTION REQUIRED |
|---|---|
| Vehicle NOT equipped with subject accessory. | No further action required. |
| CONDITION 2 | ACTION REQUIRED |
| Vehicle equipped with subject accessory. | Proceed to SECTION VI. WORK PROCEDURE. |

VI. WORK PROCEDURE

1. PREPARE THE VEHICLE

- a) Remove the keys from the ignition.
- b) Confirm the lights are turned OFF.
- c) Raise the hood.



- The illustrations in these instructions use either the left or right side to explain the procedure. Perform **ALL** work on **BOTH** right and left sides.
- Apply masking tape to the bumper, brushguard, and grill in areas where tools could make contact to avoid damage.

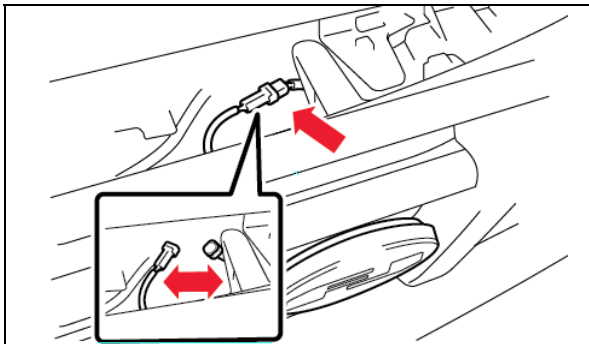

2. DISCONNECT THE AUXILIARY LIGHTS

- a) Locate and disconnect both wire harnesses behind the front grill.

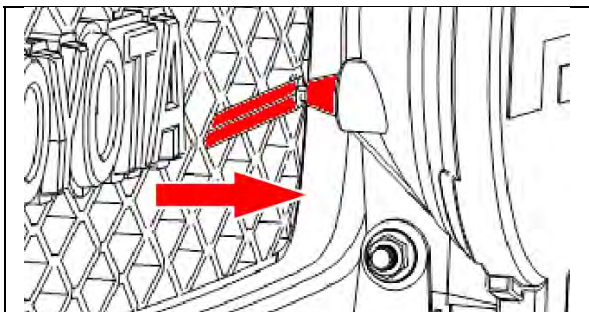

- b) Gently pull/push the wire harnesses through the grill.

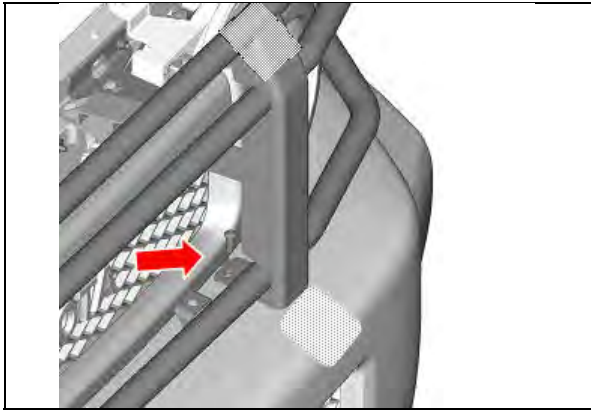

3. REMOVE BRUSHGUARD AND AUXILIARY LIGHTS

- a) Remove the screw holding the brushguard to the bumper. Perform on both sides.

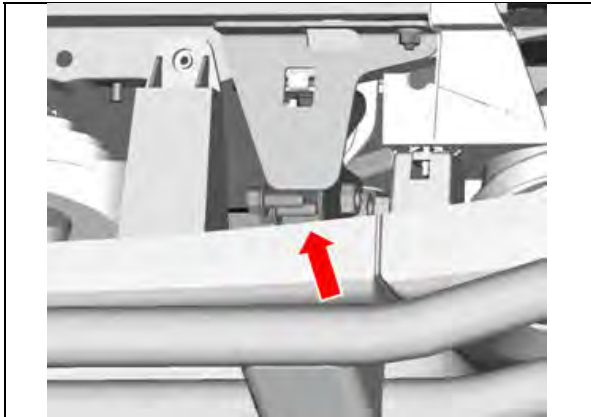

- b) Remove the 2 bolts behind the front grill. Perform on both sides.

- c) Carefully remove the brushguard and place on a soft surface.

NOTE: DO NOT scratch the brushguard or bumper.

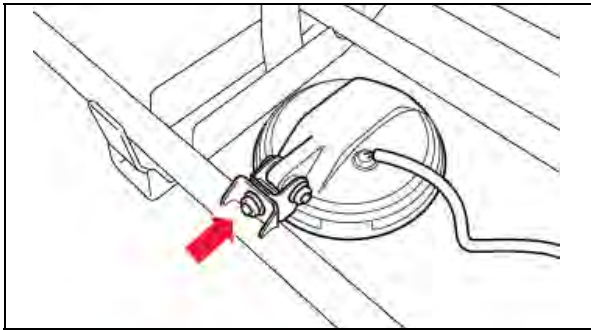

- d) Remove the nut holding the light to the brushguard. Perform on both sides.

NOTE: Keep the RH and LH lights separate so they can be reinstalled on the correct side.

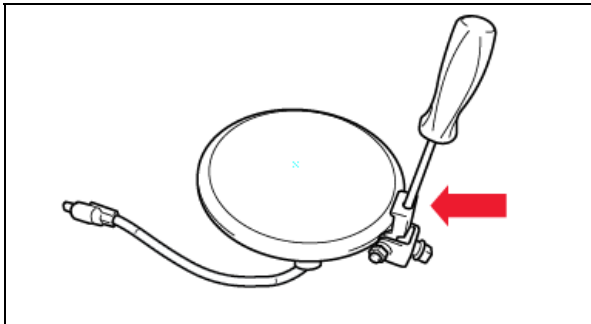

4. REMOVE THE OLD LIGHT BULB

- a) Remove the screw from the base of the light.



Perform ALL of STEPS 4-5. on BOTH lights.

- b) Carefully separate the light housing.

NOTE: DO NOT damage or stretch the wires.

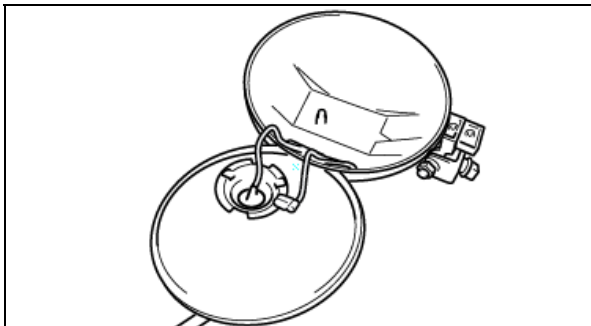

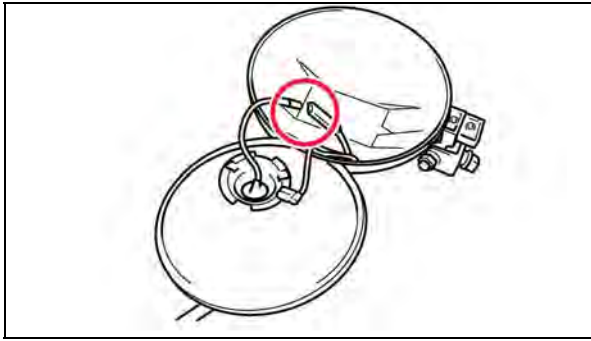

c) Disconnect the bulb wire.

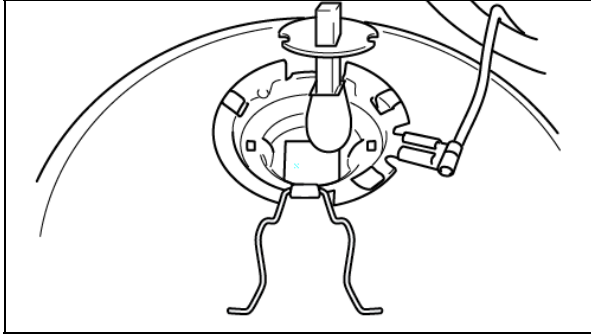

d) Squeeze and pull the clamp to release it, then remove the bulb.

STOP *DO NOT* allow dirt or debris to enter the light cavity.

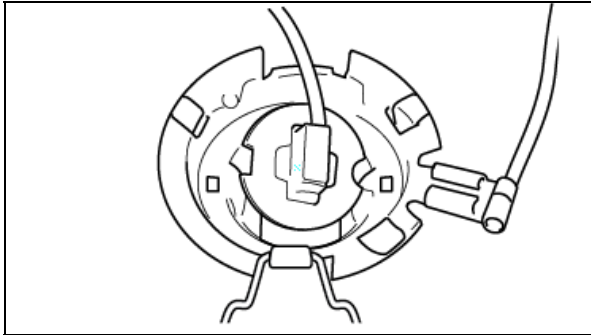

5. INSTALL THE NEW LIGHT BULB

a) Position the new bulb so that it aligns with the tabs in the housing.

b) Secure the clamp to lock the bulb in place.

STOP *DO NOT* touch the glass portion of the bulb.

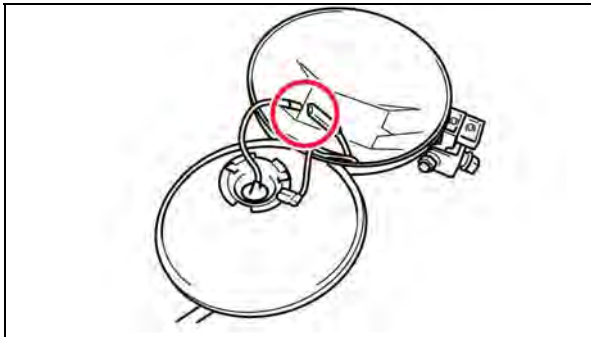

c) Connect the bulb wire.

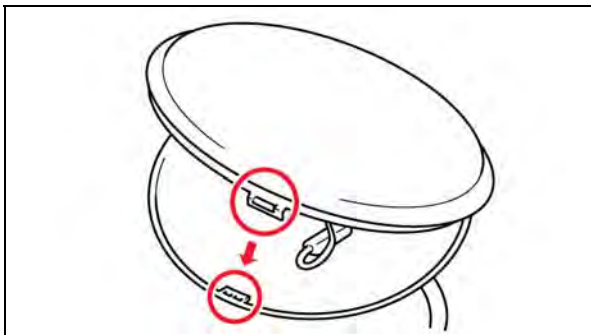

d) Insert the tab on the light into the slot on the housing.

e) Reinstall the screw.

STOP *DO NOT* pinch the wires while assembling the light housing.

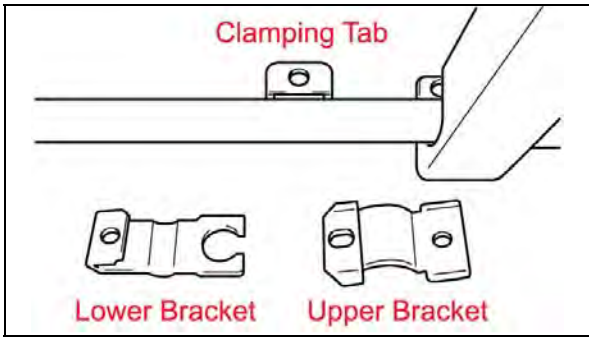

6. INSTALL THE **NEW** BRACKETS

- a) Confirm identification of the upper and lower bracket pieces and the clamping tab. The LH and RH brackets are identical.

STOP Perform **ALL** of **STEPS 6-7**. on **BOTH** sides.

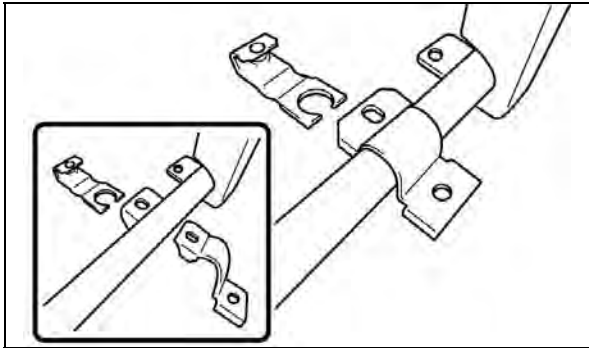

- b) Position the upper bracket above the clamping tab.

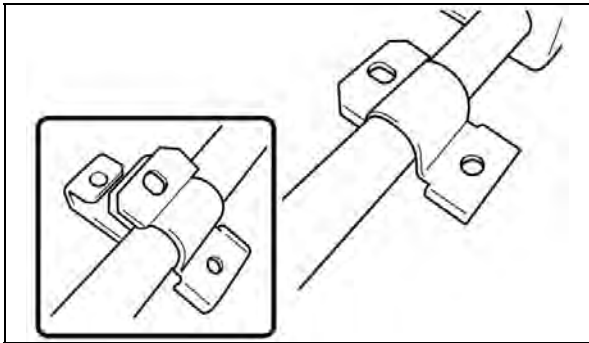

- c) Position the lower bracket below the clamping tab and slide the lower bracket into the upper bracket.

NOTE: Some maneuvering of both clamps may be required during assembly.

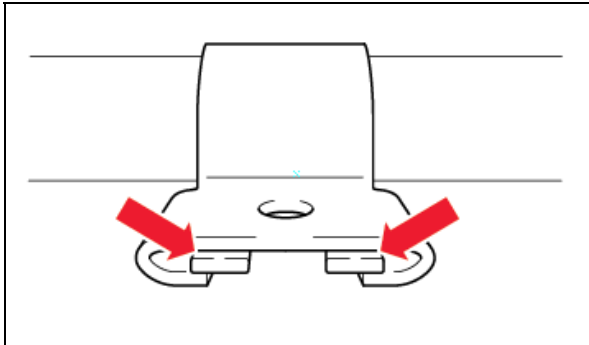

- d) Confirm the lower clamp is positioned in the upper clamp as shown.

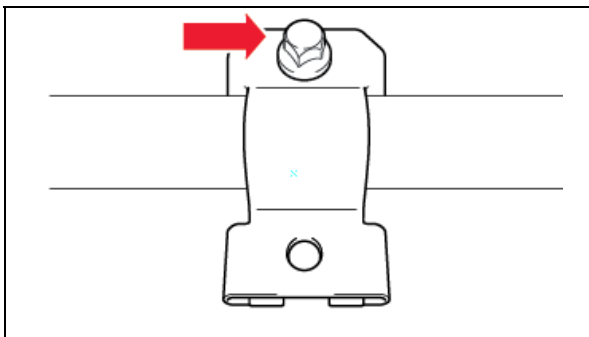

- e) Install and snug the **NEW** flange bolt. It will be torqued on a later step.

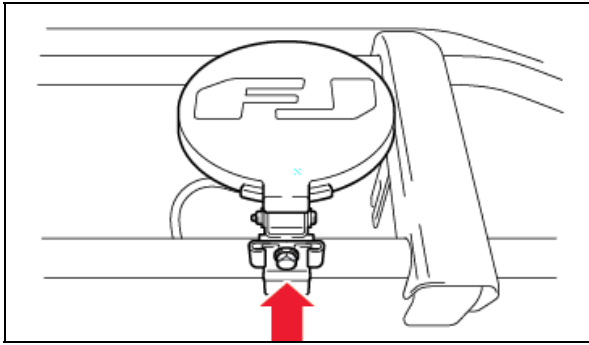

7. INSTALL THE LIGHTS

- Position the light to face straight out in front of the vehicle.
- Install the auxiliary light using the nut removed during **STEP 3**
-
-

Torque: 33ft. lbf (45N-m)

STOP Keep the light bracket parallel to the mounting bracket on the brushguard to confirm the lights face straight out.

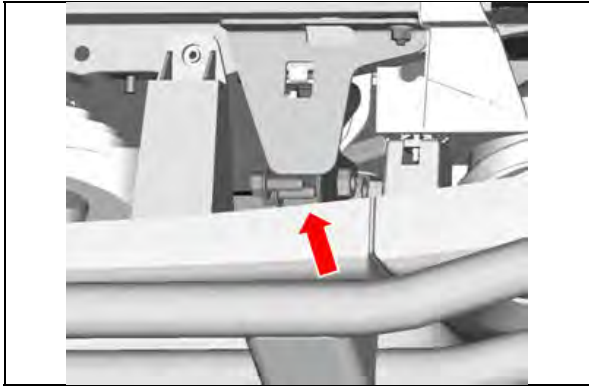

8. INSTALL THE BRUSHGUARD

- Position the brushguard.
- Install and snug the 2 bolts. Perform on both sides. They will be torqued on a later step.

NOTE: DO NOT scratch the bumper or brushguard during installation.

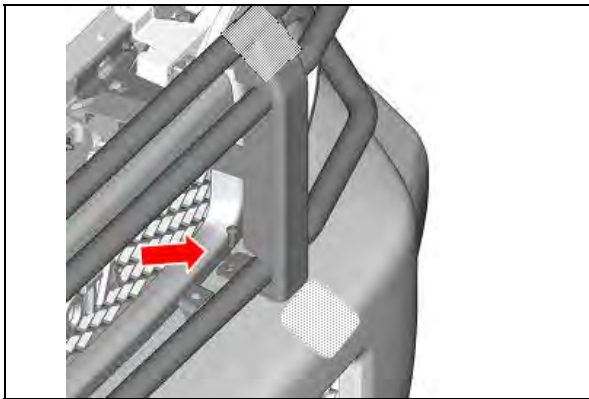

- Install the screw. Perform on both sides.

Torque: 114in. lbf (12.9N-m)

NOTE: Auxiliary lights are not shown in the illustration for clarity.

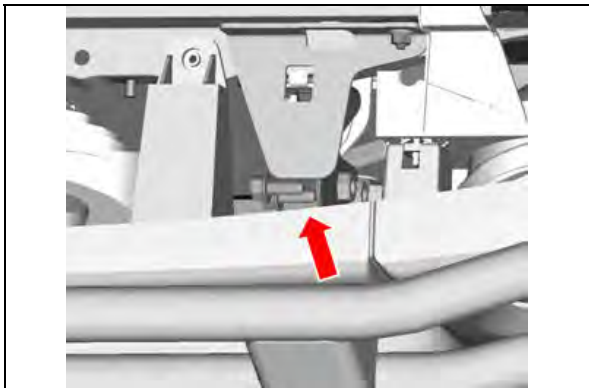

- Tighten the bolts.

Torque: 129in. lbf (14.6N-m)

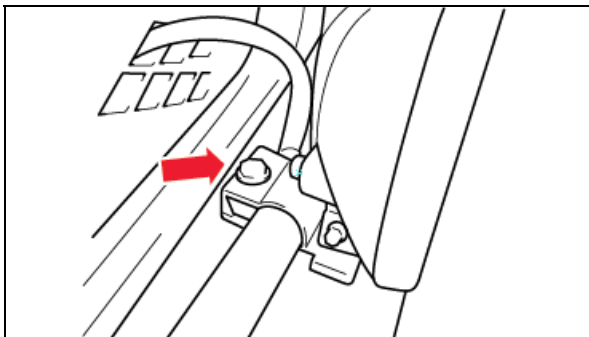

- Position the wire harnesses through the grill and connect the connectors.

- Tighten the flange bolts.

Torque: 40ft. lbf (55N-m)

- Close the hood.

9. AIM THE AUXILIARY LIGHTS

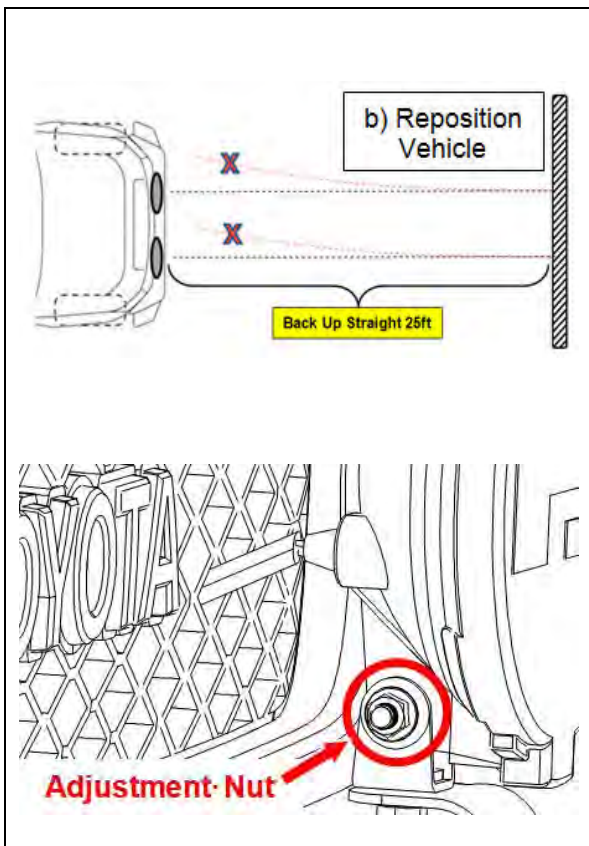
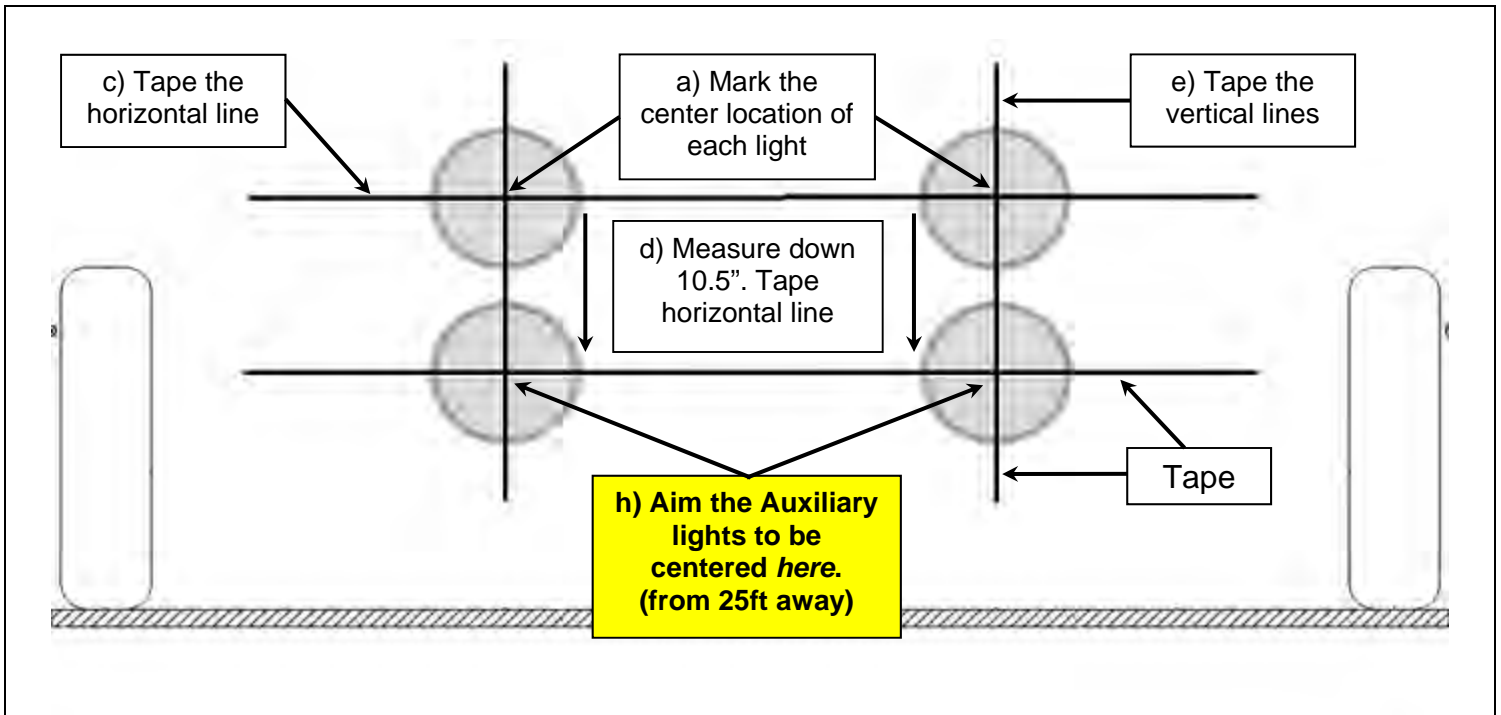

- a) Position the vehicle on a level surface with the front bumper approximately 6 inches from a vertical wall. With the vehicle lights off, mark the center location of the auxiliary lights on the wall.
- b) Reposition the vehicle 25 feet from the wall.

STOP Back the vehicle **STRAIGHT BACK** to ensure the lights will be aimed straight in the next steps.

- c) Tape a horizontal line through both headlight center locations that were marked during step a).
- d) Measure down 10.5 inches from the horizontal line and place another horizontal line on the wall.
- e) Tape 2 vertical lines that pass through the center locations marked in step a) and through both horizontal lines.
- f) Remove the lens covers from the lights.
- g) Turn on the headlights and activate the auxiliary lights by turning on the high beams.
- h) Loosen the adjustment nuts and adjust the lights to line-up with the lower crosshair.
- i) Tighten the adjustment nuts.

Torque: 15ft. lbf (20N-m)

NOTE: This procedure is best performed with low surrounding light conditions.

◀ VERIFY REPAIR QUALITY ▶

- Confirm the vehicle is equipped with the Toyota Genuine Accessory before beginning any work
- Confirm the LH and RH lights are kept separate and installed back to the same side of the vehicle
- Confirm the headlight aiming procedure is followed exactly as described

If you have any questions regarding this update, please contact your area representative.

VII. APPENDIX

A. CAMPAIGN DESIGNATION DECODER

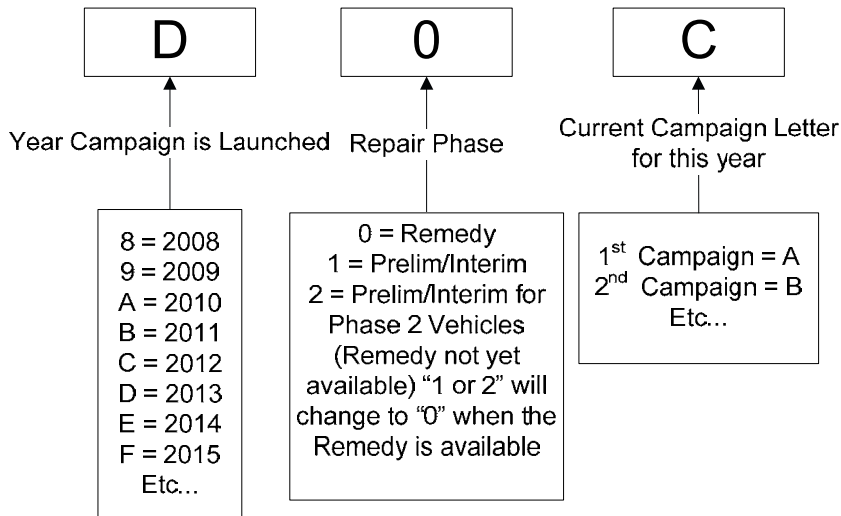

B. CAMPAIGN PARTS DISPOSAL

As required by Federal Regulations, please make sure all campaign parts (original parts) removed from the vehicle are disposed of in a manner in which they will not be reused, ***unless requested for parts recovery return.***

TECHNICAL INSTRUCTIONS
FOR
SAFETY (NON-COMPLIANCE) RECALL D0G
GENUINE TOYOTA AUXILIARY LIGHT KIT ACCESSORY
DESIGNED TO FIT 20071 – 2013 MODEL YEAR FJ CRUISER
WITHOUT BRUSHGUARD

I. OPERATION FLOW CHART

The flow chart is for reference only. **DO NOT** use it in place of the full technical instructions. Follow **ALL** steps as outlined in the full technical instructions to confirm the campaign is completed correctly.

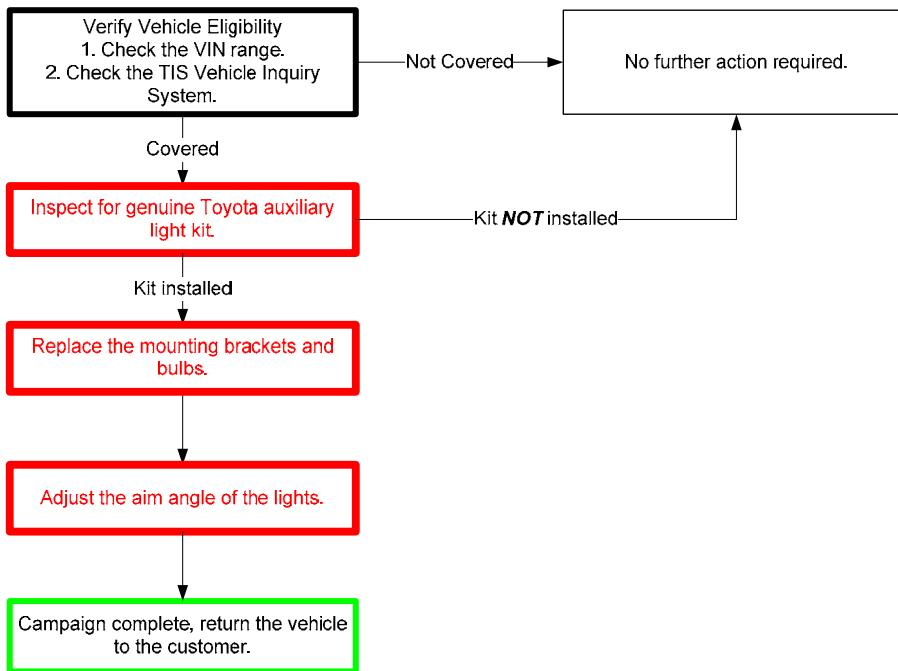

II. IDENTIFICATION OF AFFECTED VEHICLES

A. COVERED VIN RANGE

| WMI | Year | VIN Range | |
|-------|------|-----------------|-----------------|
| | | VDS | Range |
| JTE | 2007 | BU11F | 0001027-0101420 |
| | | ZU11F | 0001015-0019076 |
| | 2008 | BU11F | 0101421-0107257 |
| | | | K001003-K056845 |
| | | ZU11F | 0019077-0019919 |
| | 2009 | BU11F | K001001-K007996 |
| | | ZU11F | K056849-K070006 |
| | 2010 | BU4BF | K007997-K008509 |
| | | ZU4BF | K070007-K099142 |
| | 2011 | BU4BF | K008510-K010844 |
| | | ZU4BF | K092698-K116292 |
| | 2012 | BU4BF | K010845-K011727 |
| | | ZU4BF | K115382-K148760 |
| | 2013 | BU4BF | K011728-K012746 |
| ZU4BF | | K148761-K166714 | |
| | | | K012747-K013341 |

NOTE:

- Check the TIS Vehicle Inquiry System to confirm the VIN is involved in this Safety (Non-Compliance) Recall, and that the campaign has not already been completed prior to dealer shipment or by another dealer.
- TMS warranty will not reimburse dealers for repairs conducted on vehicles that are not affected or were completed by another dealer.

III. PREPARATION

A. PARTS

| Part Number | Part Description | Quantity |
|--|------------------------------------|----------|
| PT591-35140 | Auxiliary Light Kit, Bumper Mount* | 1 |
| *The kit above includes the following parts. | | |
| PT297-35140 | H3 Bulb, 35W, Hella | 2 |
| - | M8x20 Flange Head Bolt | 4 |
| PT591-35141-RH | RH Mounting Bracket | 1 |
| PT591-35141-LH | LH Mounting Bracket | 1 |

B. TOOLS & EQUIPMENT

- Standard hand tools
- Torque wrench
- Masking tape

IV. BACKGROUND

The subject Genuine Toyota Auxiliary Light Kit is specifically designed for 2007 to 2013 Model Year FJ Cruiser vehicles. The Auxiliary Light Kit consists of two 6-inch 55 Watt lights which are mounted on the front bumper inboard of the headlamp assemblies. The Auxiliary Light Kit can be illuminated when the driver activates the vehicle's high beam lights. The illumination of the Auxiliary Light Kit with the vehicle's high beams causes the vehicle to exceed one of the allowable lighting thresholds specified in FMVSS 108.

Without brush guard

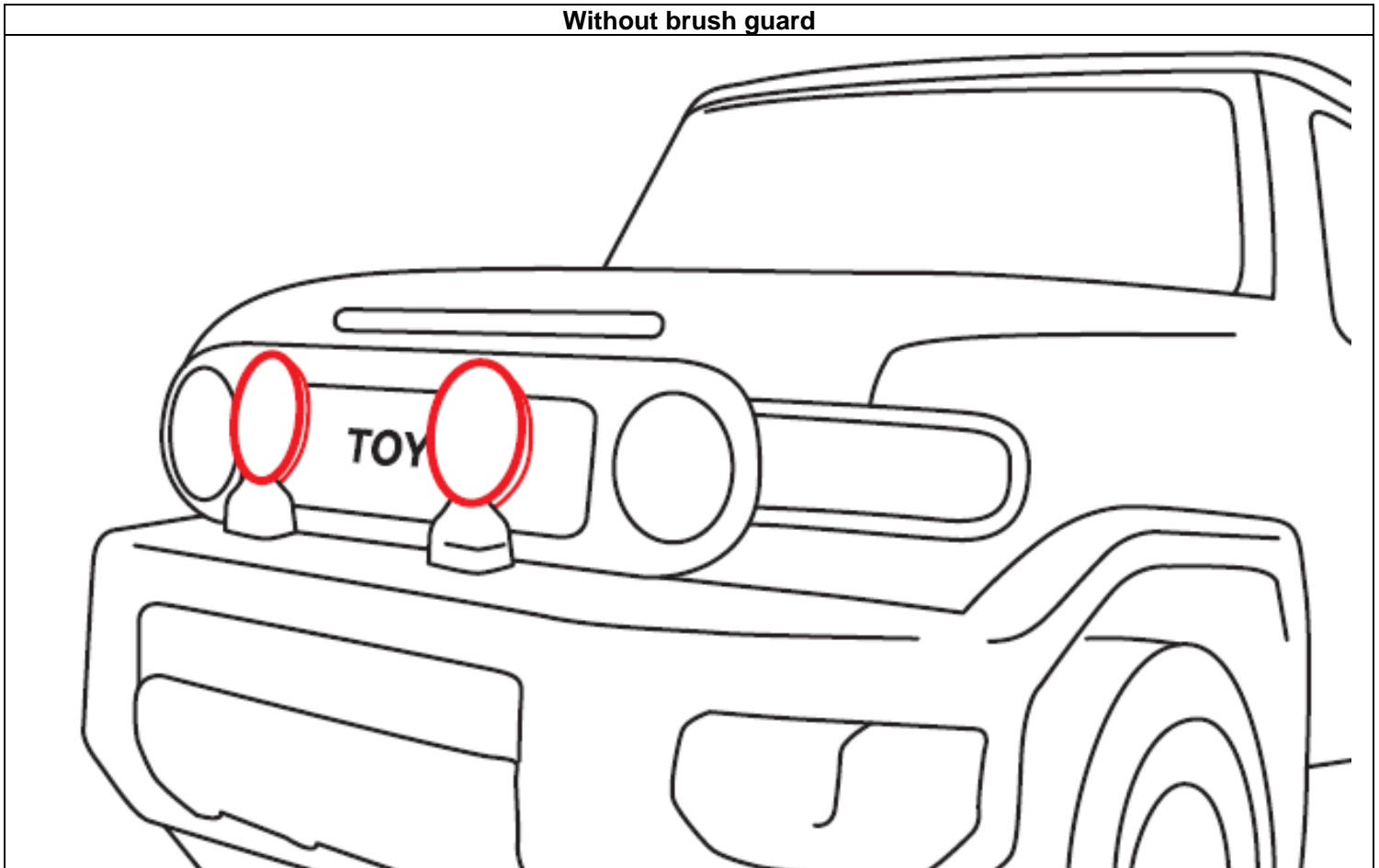

V. AUXILIARY LIGHT INSPECTION

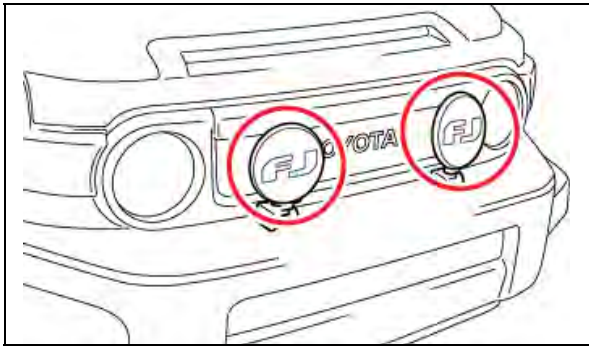

1. INSPECT FOR TOYOTA GENUINE AUXILIARY LIGHTS

- a) Visually inspect the vehicle to determine if it is equipped with the genuine Toyota auxiliary light kit accessory.

| CONDITION 1 | ACTION REQUIRED |
|---|---|
| Vehicle NOT equipped with subject accessory. | No further action required. |
| CONDITION 2 | ACTION REQUIRED |
| Vehicle equipped with subject accessory. | Proceed to SECTION VI. WORK PROCEDURE. |

VI. WORK PROCEDURE

1. PREPARE THE VEHICLE

- a) Remove the keys from the ignition.
- b) Confirm the lights are turned OFF.
- c) Raise the hood.



- The illustrations in these instructions use either the left or right side to explain the procedure. Perform **ALL** work on **BOTH** right and left sides.
- Apply masking tape to the bumper and grill in areas where tools could make contact to avoid damage.

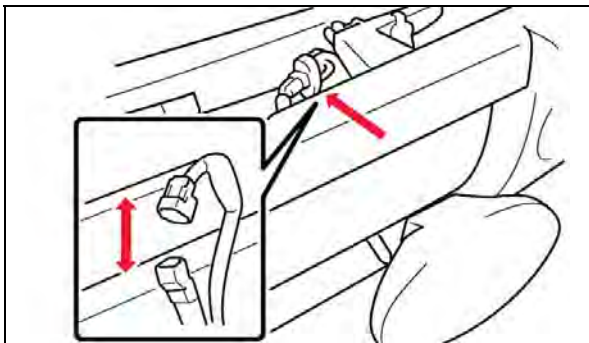

2. REMOVE THE AUXILIARY LIGHT

- a) Locate and disconnect both wire harnesses behind the front grill.

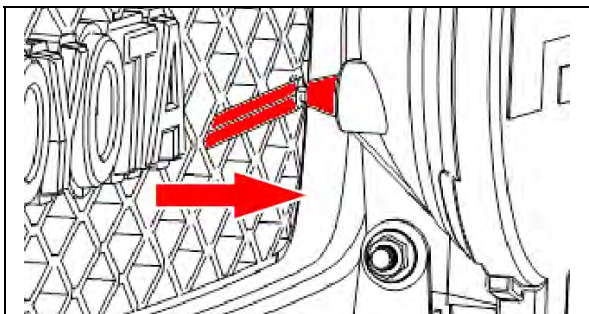

- b) Gently pull/push the wire harnesses through the grill.

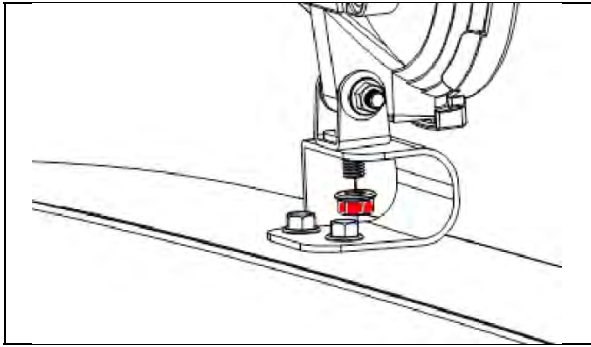

c) Remove the nut holding the light to the bracket and remove the light. Perform on both sides

d) Place the light on a soft, flat surface.

NOTE: Keep the LH and RH lights separate.

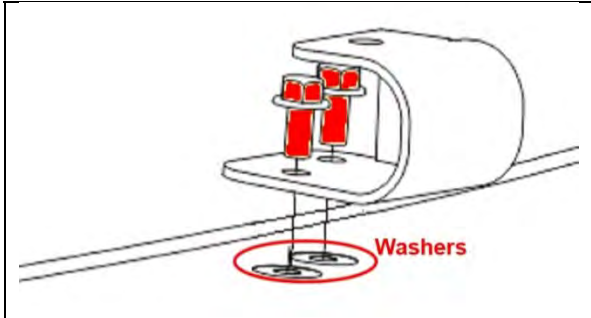

e) Remove the 2 bolts and the bracket. Perform on both sides.

NOTE:

- Confirm the 2 washers remain in place, seated flush to the bumper surface. Confirm both sides.
- Discard the brackets and bolts, they are not to be reused.

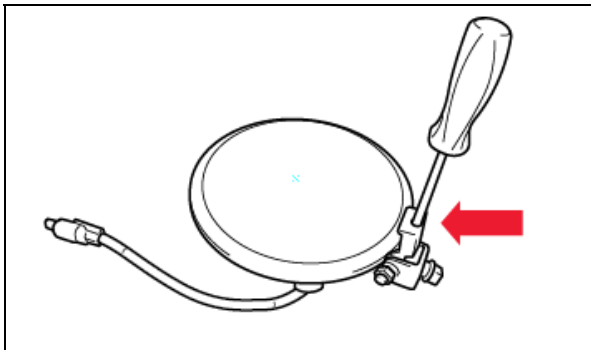

3. REMOVE THE OLD LIGHT BULB

a) Remove the screw from the base of the light.

STOP Perform ALL of STEPS 3-4. on BOTH lights.

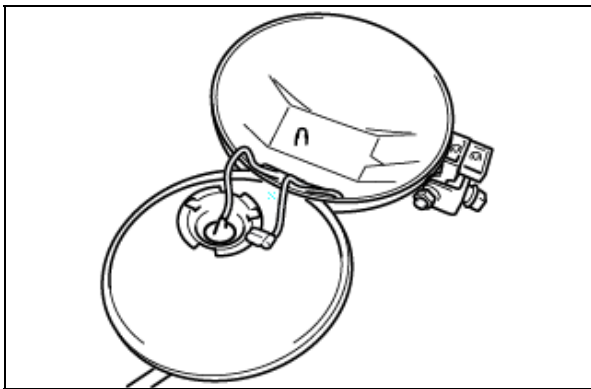

b) Carefully separate the light housing.

NOTE: DO NOT damage or stretch the wires.

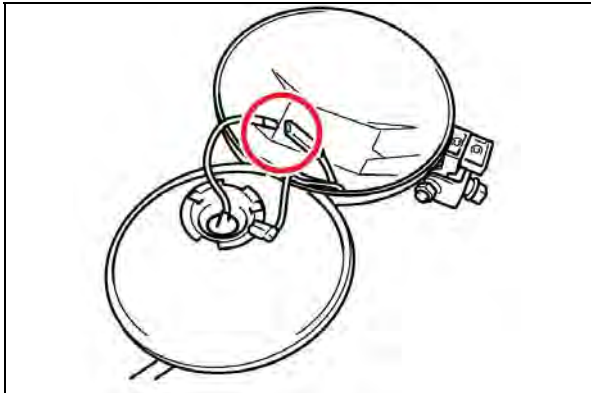

c) Disconnect the bulb wire.

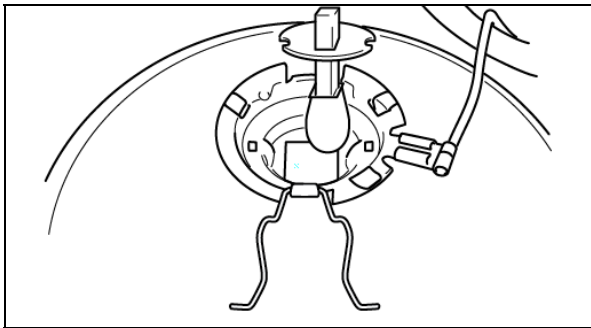

- d) Squeeze and pull the clamp to release it, then remove the bulb.



DO NOT allow dirt or debris to enter the light cavity.

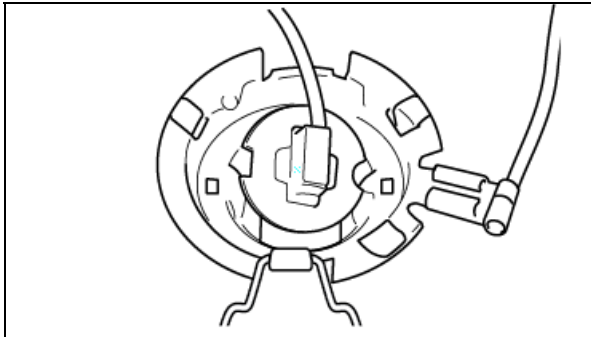

4. INSTALL THE NEW LIGHT BULB

- a) Position the new bulb so that it aligns with the tabs in the housing.
b) Secure the clamp to lock the bulb in place.



DO NOT touch the glass portion of the bulb.

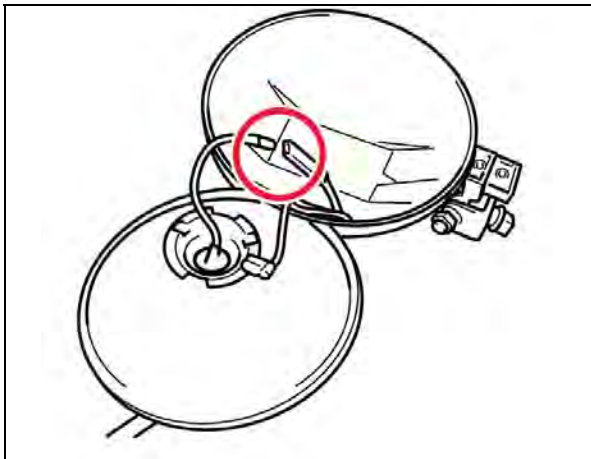

- c) Connect the bulb wire.

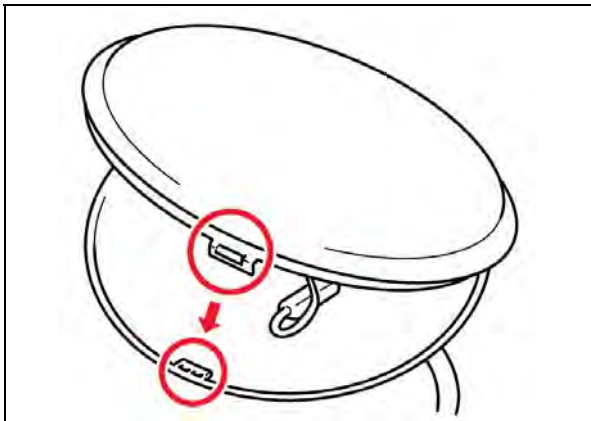

- d) Insert the tab on the light into the slot on the housing.
e) Reinstall the screw.



DO NOT pinch the wires while assembling the light housing.

5. INSTALL THE **NEW** MOUNTING BRACKET

- a) Remove the nut and bolt and remove the aim adjusting bracket from the light.

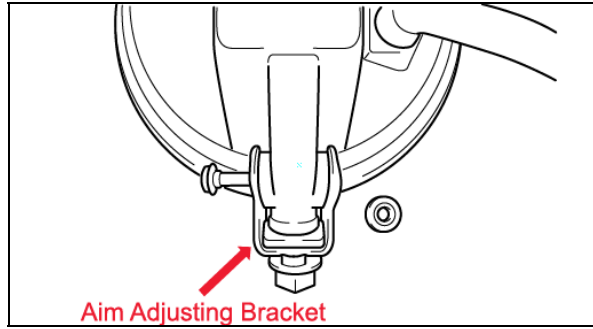

- b) Select the bracket for the light being worked on.

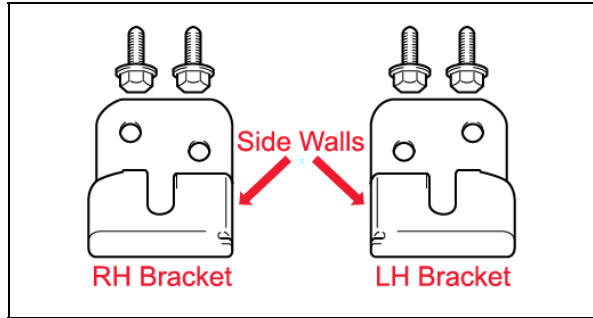

- c) Clamp the **NEW** mounting bracket in a vise.

NOTE: Protect the bracket with a shop cloth to prevent damage.

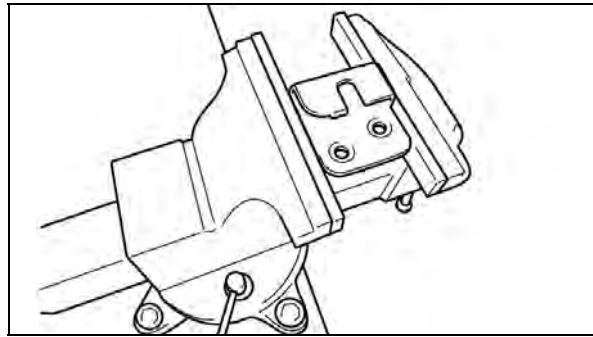

- d) Position the aim adjusting bracket and nut on the mounting bracket.

NOTE: Reuse the nut that was removed during STEP 2. c).

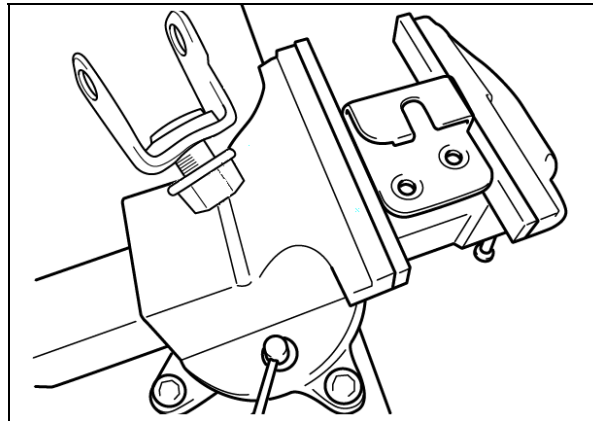

- e) Hold the aim adjusting bracket parallel with the mounting bracket with a screwdriver and torque the nut.

Torque: 33ft. lbf (45N-m)

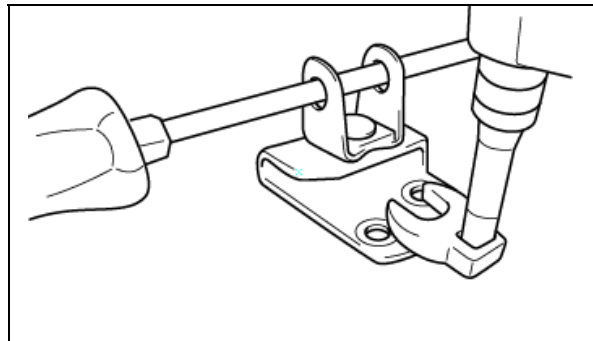

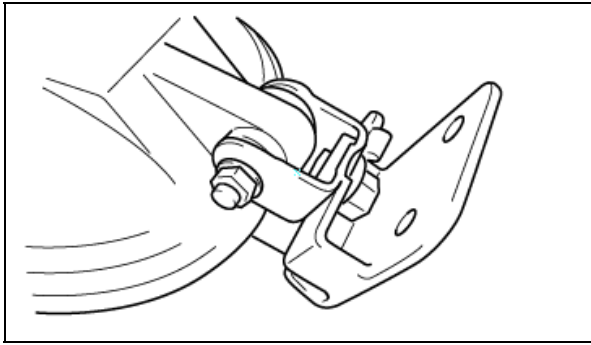

- f) Assemble the light back into the aim adjusting bracket. Snug the nut, it will be torqued on a later step.

NOTE: Confirm the nut is installed on the same side as the sidewall of the mounting bracket.

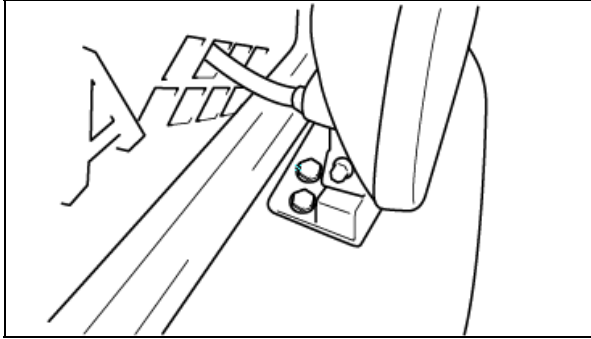

6. INSTALL THE LIGHT ASSEMBLY

- a) Use 2 **NEW** bolts to install the light assembly to the bumper.

NOTE: Confirm the sidewall on the mounting bracket faces toward the center of the vehicle.

Torque: 15ft. lbf (20N-m)

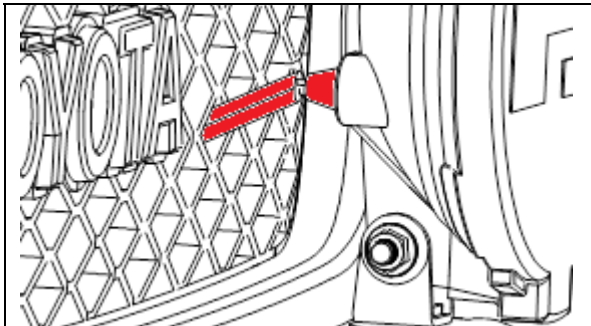

- b) Position the wire harnesses through the grill and connect the connectors.

- c) Close the hood.

7. AIM THE AUXILIARY LIGHTS

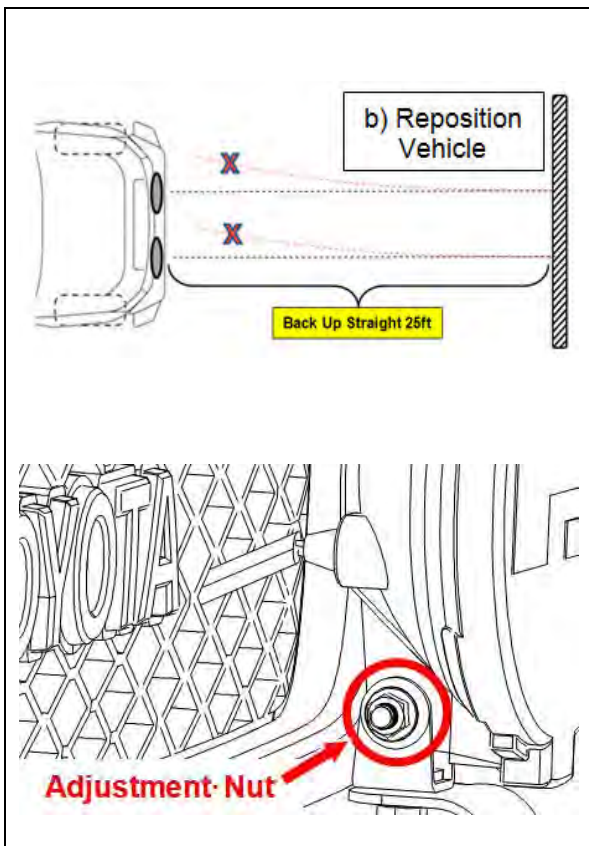
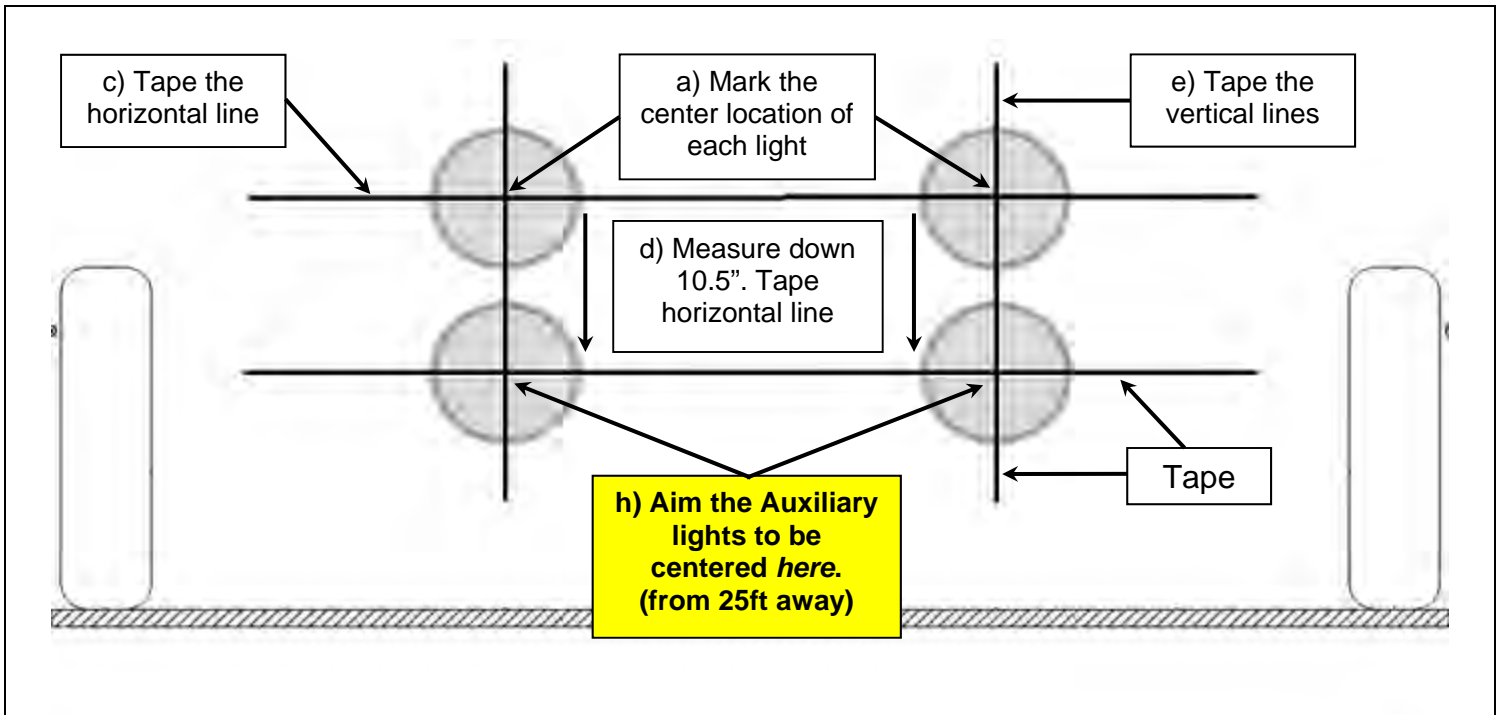

- a) Position the vehicle on a level surface with the front bumper approximately 6 inches from a vertical wall. With the vehicle lights off, mark the center location of the auxiliary lights on the wall.

- b) Reposition the vehicle 25 feet from the wall.



Back the vehicle *STRAIGHT BACK* to ensure the lights will be aimed straight in the next steps.

- c) Tape a horizontal line through both headlight center locations that were marked during step a).
- d) Measure down 10.5 inches from the horizontal line and place another horizontal line on the wall.
- e) Tape 2 vertical lines that pass through the center locations marked in step a) and through both horizontal lines.
- f) Remove the lens covers from the lights.
- g) Turn on the headlights and activate the auxiliary lights by turning on the high beams.
- h) Loosen the adjustment nuts and adjust the lights to line-up with the lower crosshair.
- i) Tighten the adjustment nuts.

Torque: 15ft. lbf (20N-m)

NOTE: This procedure is best performed with low surrounding light conditions.

◀ VERIFY REPAIR QUALITY ▶

- Confirm the vehicle is equipped with the Toyota Genuine Accessory before beginning any work
- Confirm the LH and RH lights are kept separate and installed back to the same side of the vehicle
- Confirm the headlight aiming procedure is followed exactly as described

If you have any questions regarding this update, please contact your area representative.

VII. APPENDIX

A. CAMPAIGN DESIGNATION DECODER

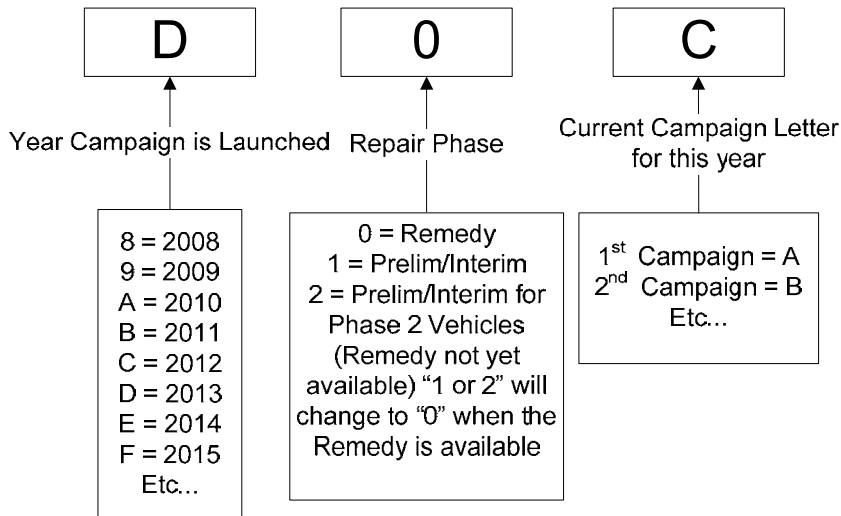

B. CAMPAIGN PARTS DISPOSAL

As required by Federal Regulations, please make sure all campaign parts (original parts) removed from the vehicle are disposed of in a manner in which they will not be reused, ***unless requested for parts recovery return.***

Lonnie Peterson / TMS Toyota Customer Services
Product Quality and Service Support, Quality Compliance
May 30, 2013
Approved By: Bob Waltz

To: All Toyota Dealers
From: Product Support Division

Safety (Non-Compliance) Recall D0G – *Remedy Available*
Genuine Toyota Auxiliary Light Kit Accessory
Designed to fit 2007 to 2013 Model Year FJ Cruiser Vehicles

As previously announced, in April 2013, Toyota filed a Noncompliance Information Report (NCIR) with the National Highway Traffic Safety Administration (NHTSA) informing the agency that certain 2007 to 2013 Model Year FJ Cruiser vehicles equipped with the Genuine Toyota Auxiliary Light Kit accessory fail to conform to a provision of Federal Motor Vehicle Safety Standard (FMVSS) 108. There are approximately 11,500 Genuine Toyota Auxiliary Light Kits which were installed at vehicle processing centers, by dealers, or sold over the counter.

- **Toyota has completed remedy preparations and will begin to notify owners in Late May, 2013.**
- A Dealer Letter containing additional information (i.e. Technical Instructions, reimbursement procedures, parts ordering information, etc.) has been posted on TIS.
- ***Please refer to TIS for vehicle applicability and additional information.***

Customer and Media Contacts

- A FAQ has been attached for your use in the event you receive a customer contact. If a customer has further questions, please direct the inquiry to the Toyota Customer Experience Center at 1-800-331-4331.
- If you are a dealership associate and have any questions, please contact your District Service/Parts Manager.
- ***In the event you are contacted by the News media***, it is imperative that all media contacts (local and national) receive a consistent message. Please direct all media contacts to Cindy Knight (310) 468-2170, in Toyota Corporate Communications. (Please do not provide these numbers to customers or call if you are a dealer associate. Please provide these contacts to only media associates.)



Safety (Non-Compliance) Recall D0G (D1G) – Remedy Notice
Genuine Toyota Auxiliary Light Kit Accessory
Designed to fit 2007 to 2013 Model Year FJ Cruiser Vehicles

Customer Frequently Asked Questions

Published late May, 2013

We are providing the following information to keep you informed of the recall details.

Background

As previously announced, in April 2013, Toyota filed a Non-Compliance Information Report (NCIR) with the National Highway Traffic Safety Administration (NHTSA) informing the agency that 2007 to 2013 Model Year FJ Cruiser vehicles equipped with the Genuine Toyota Auxiliary Light Kit accessory kit fail to conform to a provision of Federal Motor Vehicle Safety Standard (FMVSS) 108. There are approximately 11,500 Genuine Toyota Auxiliary Light Kits which were installed at vehicle processing centers, by dealers, or sold over the counter.

Q1: What is the condition?

A1: The subject Genuine Toyota Auxiliary Light Kit is specifically designed for 2007 to 2013 Model Year FJ Cruiser vehicles. The Auxiliary Light Kit consists of two 6-inch 55 Watt lights which are mounted on the front bumper inboard of the headlamp assemblies. The Auxiliary Light Kit can be illuminated when the driver activates the vehicle's high beam lights. The illumination of the Auxiliary Light Kit with the vehicle's high beams causes the vehicle to exceed one of the allowable lighting thresholds specified in FMVSS 108. Light intensities above the maximum allowable limit could cause increased glare for oncoming traffic and increase the risk of a crash.

Q1a: What is the Genuine Toyota Auxiliary Light Kit?

A1a: The Genuine Toyota Auxiliary Light Kit is an optional Toyota accessory which consists of two bumper or brush guard mounted 6-inch round lights and two FJ branded covers to protect the lights when not in use. Please refer to the following images for reference.

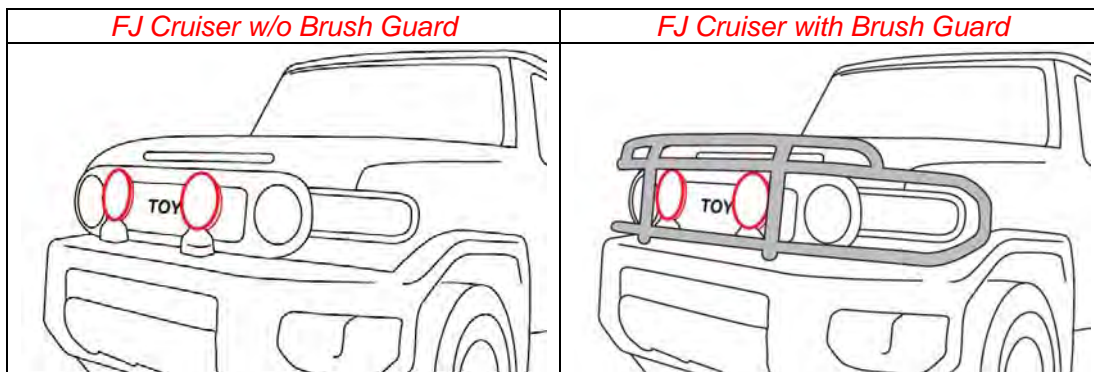

Q2: How many Genuine Toyota Auxiliary Light Kits are covered by this Safety (Non-Compliance) Recall?

A2: There are approximately 11,500 Genuine Toyota Auxiliary Light Kits which were installed at vehicle processing centers, by dealers, or sold over the counter for 2007 to 2013 Model Year FJ Cruiser Vehicles.

Q2a: Are there any other Toyota or Lexus vehicles covered?

A2a: No. The Genuine Toyota Auxiliary Light Kit was designed only for use on 2007 to 2013 FJ Cruiser models.

Q2b: Which and how many vehicles are covered by this Safety Recall?

A2b: There are approximately 11,500 vehicles that could have the Genuine Toyota Auxiliary Light Kit accessory installed. To ensure that dealer installations and over-the-counter accessory sales customers are notified, approximately 209,000 letters will be mailed to all 2007 through certain 2013 Model Year FJ Cruiser owners.

Q3: What is Toyota going to do?

A3: If the vehicle is equipped with a Genuine Toyota Auxiliary Light Kit, any authorized Toyota dealer will replace the Auxiliary Light Brackets and Bulbs at **NO CHARGE** to the vehicle owner. Only vehicles equipped with a Genuine Toyota Auxiliary Light Kit will require repair.

Q3a: How and when will Toyota notify owner of vehicles covered by this Safety (Non-Compliance) Recall?

A3a: The owner notification is anticipated to start in late May, 2013.

There are approximately 11,500 Genuine Toyota Auxiliary Light Kits which were installed at vehicle processing centers, by dealers, or sold over the counter. In order to identify all the vehicles which may have the Genuine Toyota Auxiliary Light Kit installed Toyota will be mailing owner notices to all owners of 2007 to 2013 model year FJ Cruiser vehicles; this mailing will include approximately 209,000 letters.

If the vehicle does **NOT** have the Genuine Toyota Auxiliary Light Kit, it is **NOT** involved in this Safety Recall.

Q3b: How does Toyota obtain my mailing information?

A3b: Toyota uses an industry provider who works with each state Department of Motor Vehicles (DMV) to receive registration or title information. Please make sure your registration or title information is correct.

Q3c: Do I need my owner letter to have the remedy performed?

A3c: You do not need an owner letter to have this recall completed; however, to assist the dealer in confirming vehicle eligibility, we request that you present the owner notification at the time of your service appointment.

Q4: Can I inspect my vehicle to determine if it has the Genuine Toyota Auxiliary Light Kit?

A4: Yes, you can reference the images shown below to determine if your vehicle is equipped with the optional Genuine Toyota Auxiliary Light Kit accessory.

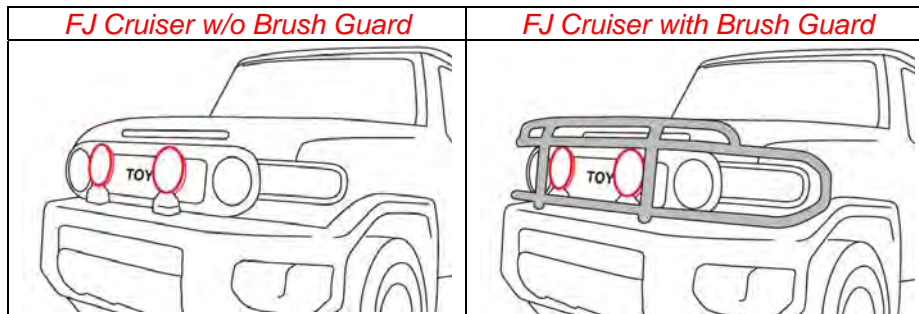

If so equipped, please contact your local authorized Toyota dealer as soon as possible to schedule an appointment to have the remedy performed.

If the vehicle does **NOT** have the Genuine Toyota Auxiliary Light Kit, it is **NOT** involved in this Safety Recall and no additional action is necessary.

Q4a: What if I am not comfortable performing the inspection?

A4a: Any authorized Toyota dealer will be more than happy to perform an inspection at **no charge** to you to determine if your vehicle is covered by this safety recall.

Q5: How long will the repair take?

A5: If your vehicle is equipped with a Genuine Toyota Auxiliary Light Kit accessory, the repair will take approximately 2 hours. However, depending upon the dealer's work schedule, it may be necessary to make the vehicle available for a longer period of time.

Q6: What if I previously paid for repairs to my vehicle for this condition?

A6: Please refer to the remedy owner letter for instructions to request reimbursement for previous repair costs. Please note that the dealer must complete the Safety Recall remedy before reimbursement consideration requests can be processed.

Q7: What if an owner has additional questions or concerns?

A7: If you have additional questions or concerns please contact the Toyota Customer Experience Center at 1-888-270-9371 Monday through Friday, 5:00 am to 6:00 pm, or Saturday 7:00 am through 4:00 pm Pacific Time.