



Applies To: **2012–13 Odyssey** – Check the iN VIN status for eligibility

October 15, 2013

## Safety Recall: 2012–13 Odyssey Shift Interlock Stopper

(Supersedes 13-036, dated May 21, 2013, to revise the information marked by the black bars)

### REVISION SUMMARY

Under REPAIR PROCEDURE, step 15, revised text in first and second bullet steps to match the video. Also added a note to first bullet step describing consequences of not following that step exactly as shown.

### BACKGROUND

In sub-freezing temperatures, it is possible to move the shift lever out of P without pressing the brake pedal.

### CUSTOMER NOTIFICATION

Owners of affected vehicles will receive a notification of this campaign.

Do an **iN VIN status inquiry** to make sure the vehicle is shown as eligible.

Some vehicles affected by this campaign may be in your new or used vehicle inventory. These vehicles **must** be repaired before they are sold.

Should your dealership sell an unrepaired vehicle that subsequently causes injury or damage because of the recalled item, the dealership will be solely responsible to the damaged party, and will be required to defend and indemnify American Honda for any resulting claims. To see if a vehicle in inventory is affected by this recall, do a VIN status inquiry before selling it.

### CORRECTIVE ACTION

Replace the shift interlock stopper.

### PARTS INFORMATION

Shift Interlock Stopper: P/N 06540-T0A-A81

### TOOL INFORMATION

KTC Trim Tool Set: T/N SOJATP2014

Snap-On Pick Tool (or equivalent): T/N SG3ASH90B

### WARRANTY CLAIM INFORMATION

Operation Number: 2151C9

Flat Rate Time: 0.7 hour

Failed Part: P/N 54123-SLE-J51

Defect Code: 5GU00

Symptom Code: S9700

Skill Level: Repair Technician

### REPAIR PROCEDURE

1. Remove the driver's and passenger's heater panels by pulling the panels out to detach the clips and release the hooks, then release the panel from the stud.

#### DRIVER'S SIDE

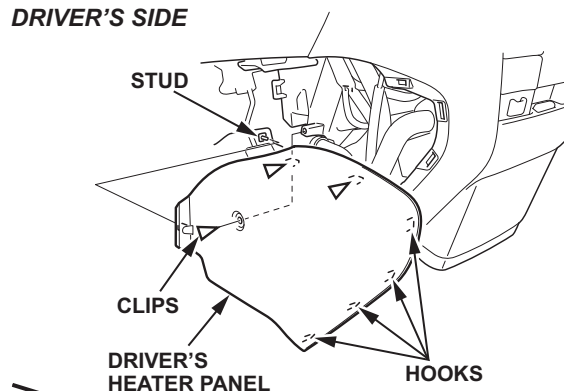

#### PASSENGER'S SIDE

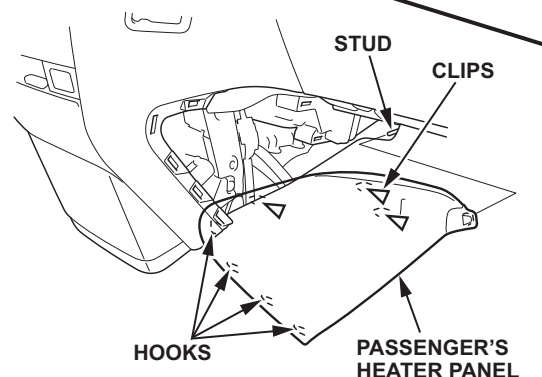

2. Pull out the center middle panel to detach the clips, then remove it.

NOTE: Use the appropriate trim tool to avoid damaging or scratching the panel, the dashboard, or any related parts during removal.

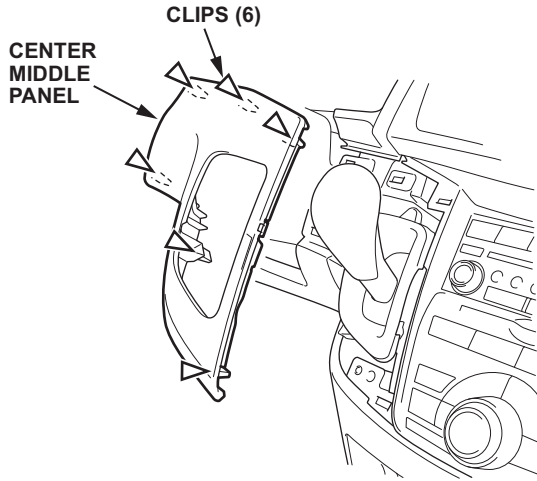

3. Pull out the passenger's dashboard side lid to detach the clips, then remove it.

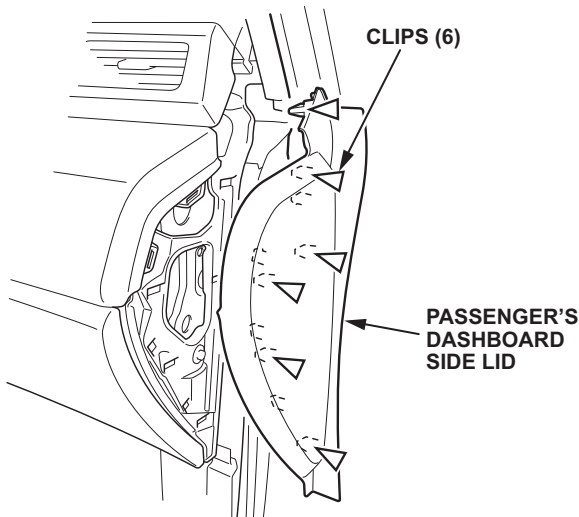

4. Pull out the passenger's middle panel to detach the clips and to release the hook, then remove it.

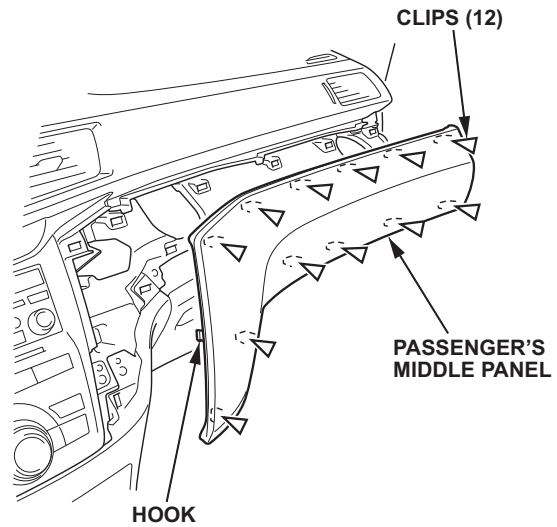

5. Remove the screws securing the center lower console.

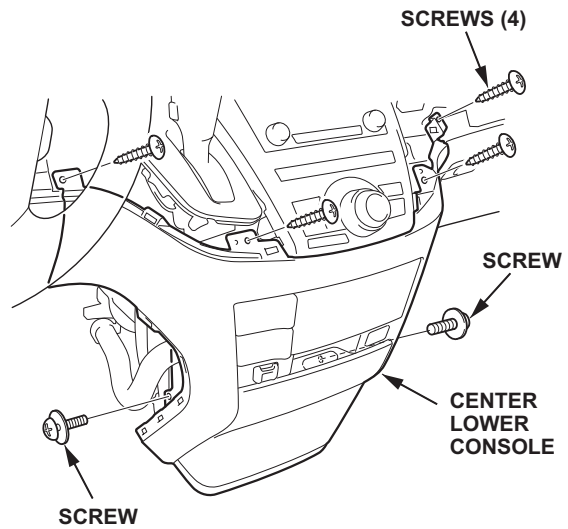

6. Pull the console out far enough to detach the clips, then disconnect the humidity/in-car temperature sensor connector and the cool box hoses.

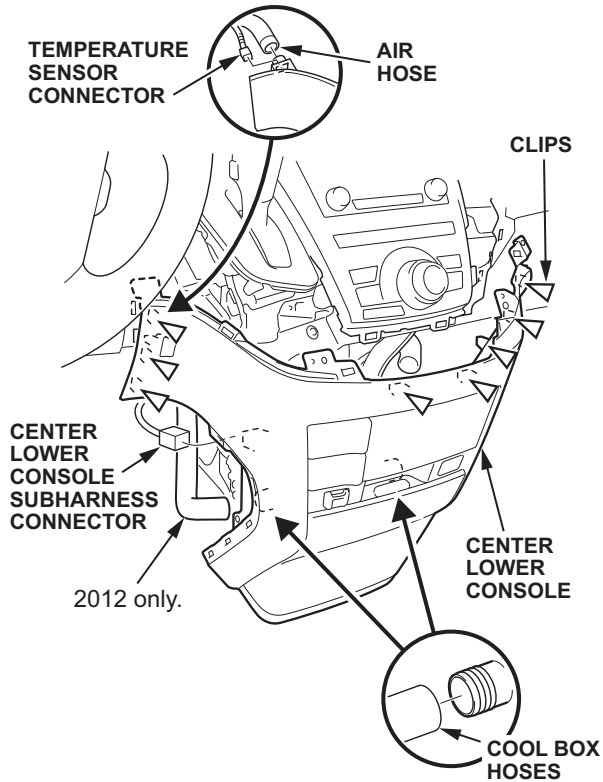

7. Make sure the parking brake is applied, then press the interlock shift button to move the shift lever to R. Insert a pin (6 mm diameter) into the positioning holes to lock the shift lever assembly in R.

NOTE: Make sure there are no burrs on the pin.

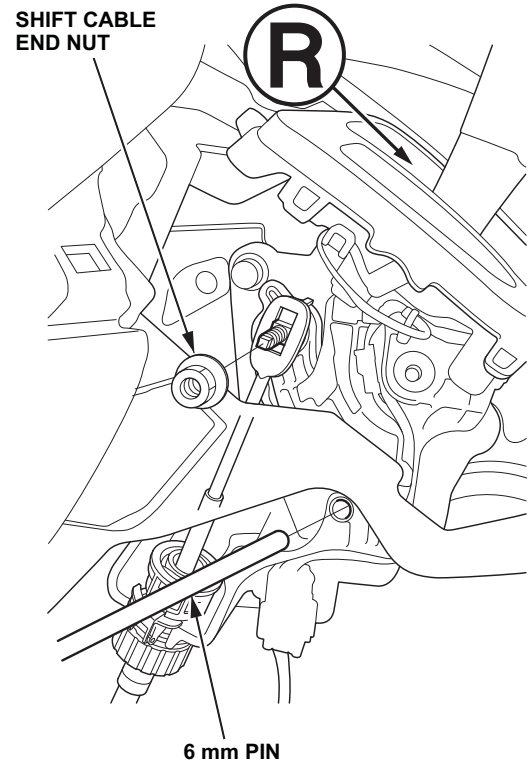

8. Remove the nut securing the shift cable end.  
NOTE: Do not use an impact gun because the vibration on the shift cable could break the shift cable guide. If this happens, the entire shift cable must be replaced.

- Remove the shift cable from the shift cable bracket. First click on the video below to see how the step is done.

NOTE: The dashboard brackets may have sharp edges. Wear gloves to protect your hands.



- Release the retainer lock.

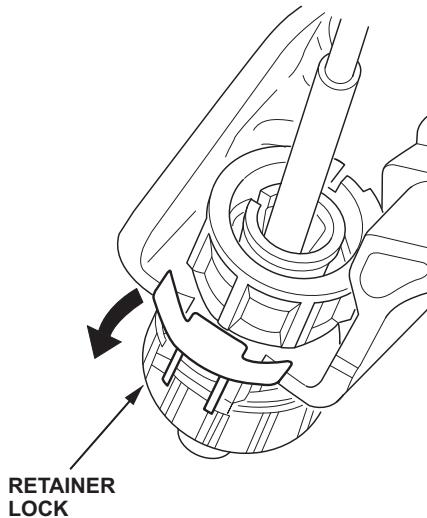

- Rotate the upper half (above the retainer lock) of the socket holder retainer counterclockwise until it stops turning.

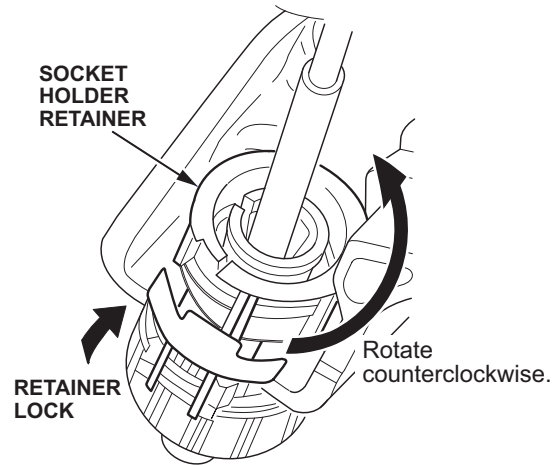

- Once the retainer stops rotating, push the retainer lock into the socket holder retainer to lock the socket holder retainer in place.

NOTE:

- Make sure the retainer lock properly locks the retainer because the retainer is spring loaded and will release if let go. If it does release, reset it by rotating the upper half of the socket holder.
- Do not rotate the lower half of the socket holder retainer (below the retainer lock), or it may break.
- Remove the shift cable by holding the socket holder retainer, and sliding it off of the shift cable bracket.

NOTE: Do not remove the shift cable by pulling on the shift cable guide, or the guide may break. If this happens, the entire shift cable must be replaced.

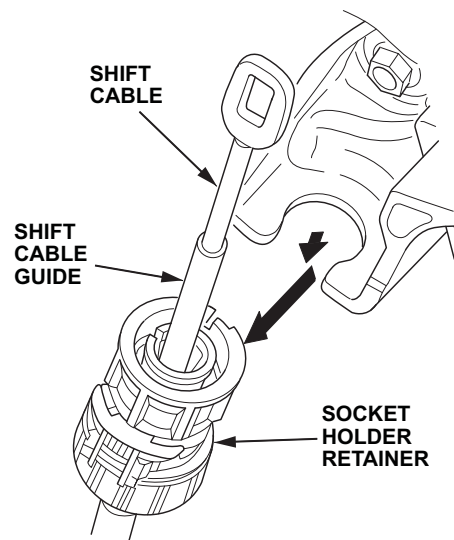

10. Remove the shift lever assembly from the instrument panel.

- Disconnect the shift lever connector.
- Remove the shift lever mounting bolts and nut.

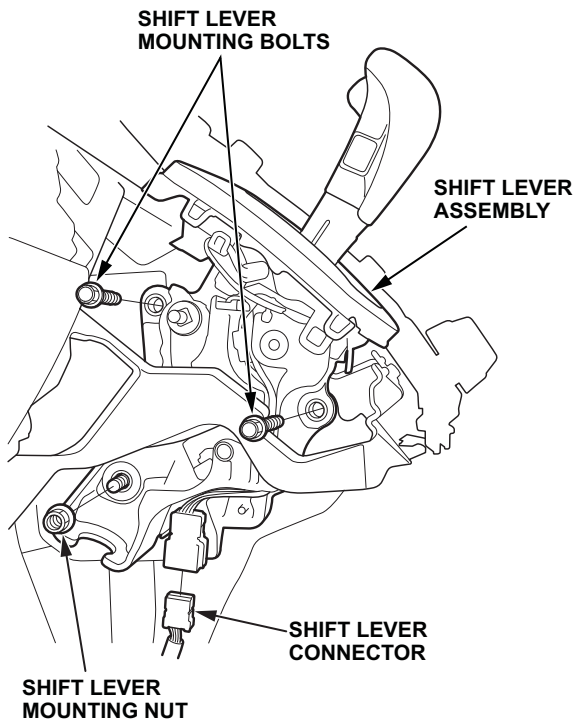

- Remove the pin (6 mm diameter) that you inserted earlier to lock the shift lever assembly in the R position.

11. Move the shift lever to N to avoid interference between the shift knob and the PRNDL trim.

NOTE: Lay the shift lever assembly on a clean cloth to prevent damaging it.



12. Move the PRNDL trim to access the shift interlock release.

- Unsnap the four tabs.

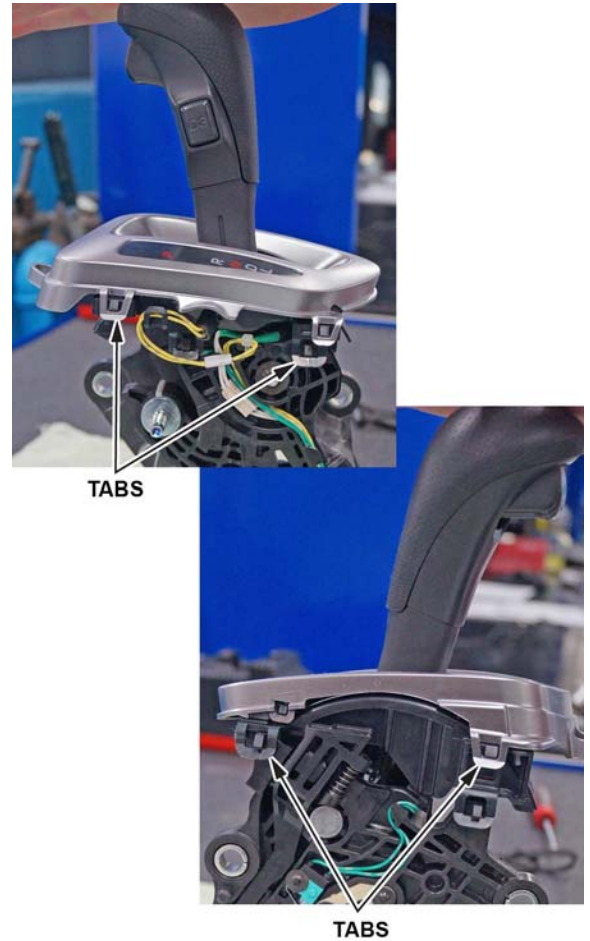

- Move the shift lever to L.





- Move the PRNDL trim down as shown.

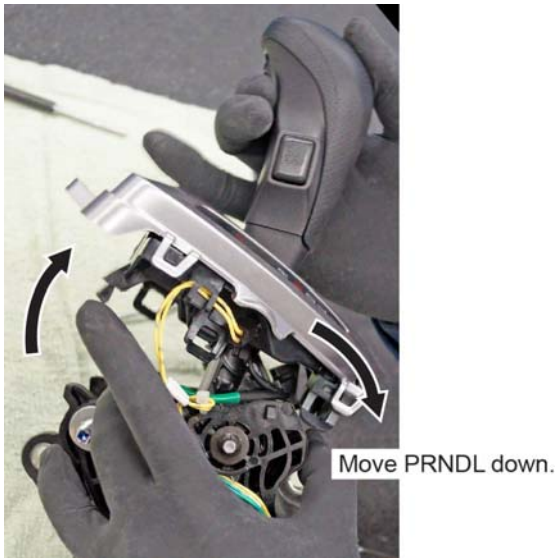

13. Release the shift interlock release by using a pick tool or small flat blade screwdriver (3 mm diameter) to push the tab down and in toward the shift interlock release.

**SHIFT LOCK RELEASE**

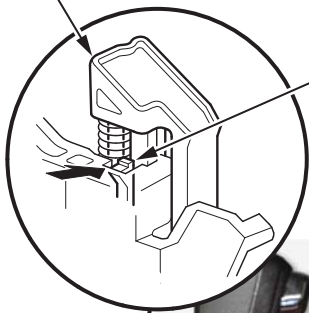

Push tab down and in towards shift lock release.



14. After unlocking the tab, lay the shift lever assembly on its side, and remove the shift interlock release and spring.

NOTE: Make sure you don't lose or damage the spring.

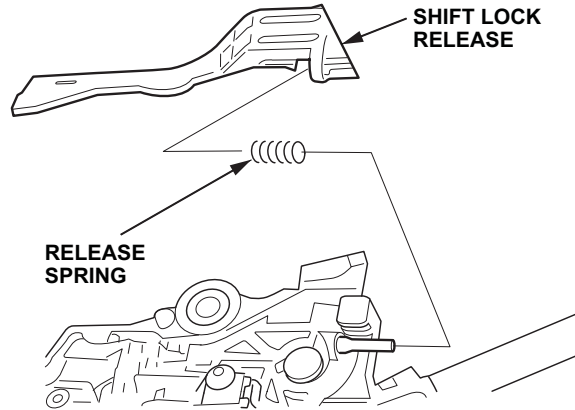

15. Remove the shift interlock solenoid. First click on the video below to see the step is done.

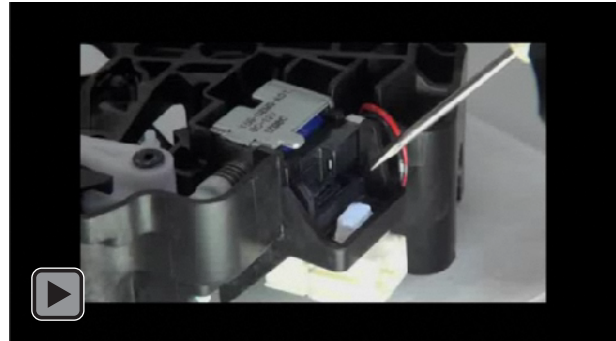

- Insert a flat-head screwdriver into the slotted tab.  
NOTE: **Make sure you insert the screwdriver in the exact specified location as shown.** If you do not, you can damage the windings when you pry out the solenoid, causing it to short out. This damage will result in the shift lever unable to come out of Park.

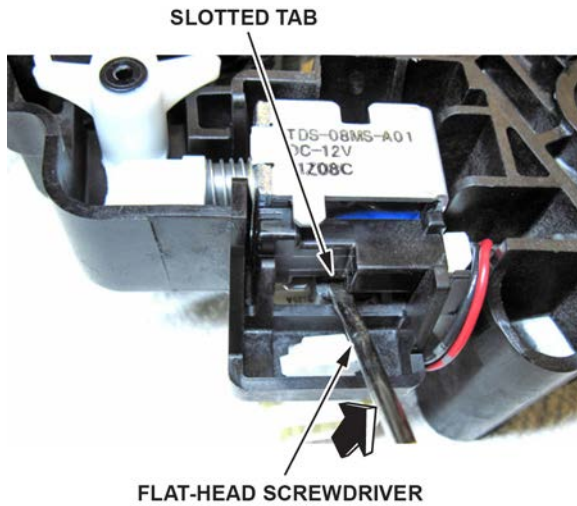

- Move the screwdriver handle up to release the tab and pry out the solenoid.

- Remove the shift interlock solenoid from the selector lever assembly and lay it down next to the shift lever assembly. Do not disconnect the connector.

NOTE: The solenoid plunger and its spring can fall out of the solenoid. If this happens, reassemble the shift interlock solenoid before setting it down.

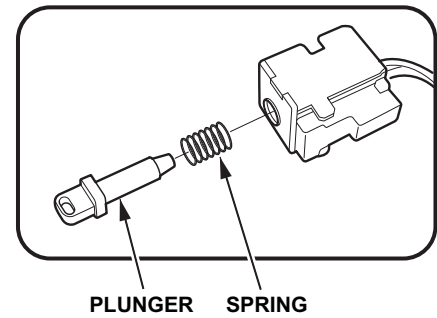
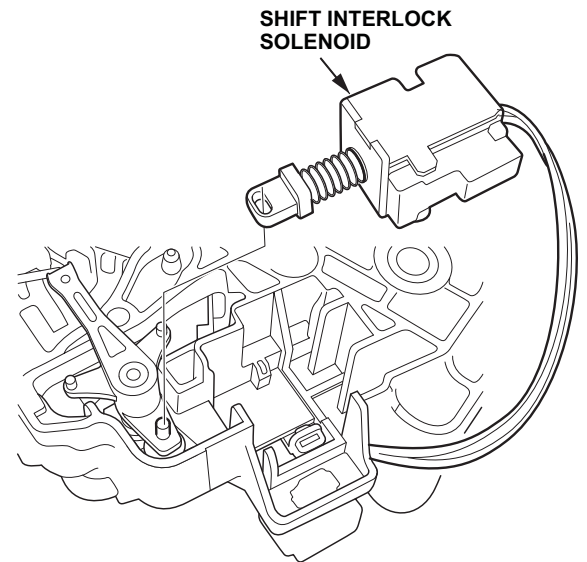

16. Remove the white shift interlock stopper from the shift lever assembly.

NOTE: Do not wipe the grease from the shift lever assembly.

**WHITE SHIFT INTERLOCK STOPPER**  
Remove.



**SHIFT INTERLOCK STOPPER**

Do not wipe off the grease.

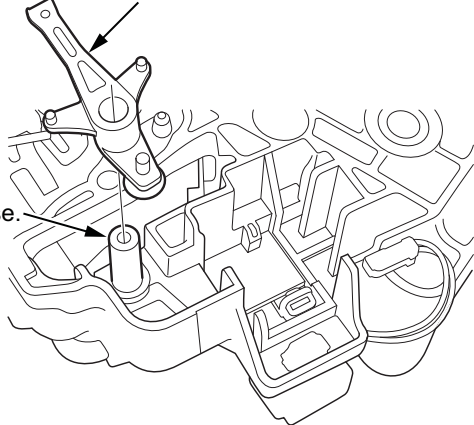

17. Install the new (blue) shift interlock stopper.

NOTE: Do not wipe the grease off the new shift interlock stopper.

> Shift Interlock Stopper

**BLUE SHIFT INTERLOCK STOPPER**

Do not wipe off the special grease applied to the shift lock stopper.

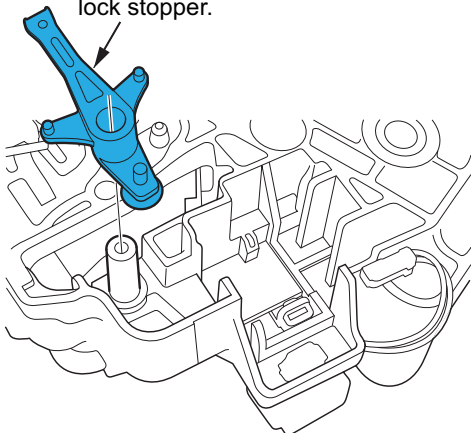

18. Reinstall the shift interlock solenoid by aligning the solenoid plunger joint with the tip of the shift interlock stopper, then push down on the bottom area of the solenoid (side with the printing) until you hear a click.

**SHIFT LOCK SOLENOID**

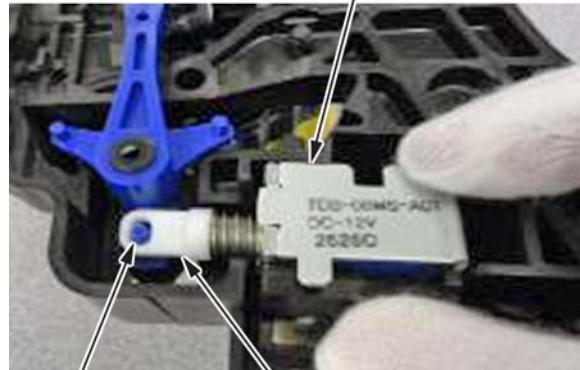

**TIP OF SHIFT LOCK STOPPER**

**JOINT OF SOLENOID**





19. Check that the shift interlock stopper and solenoid motion is smooth.

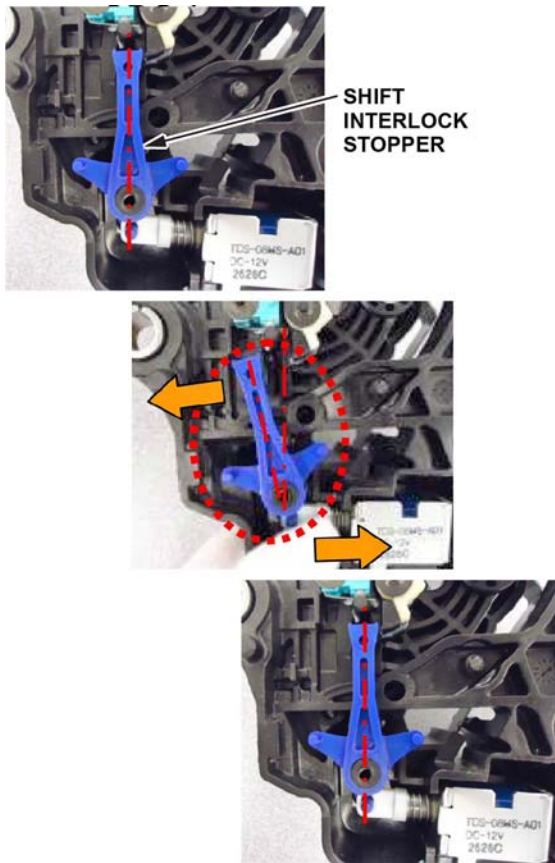

20. Reinstall the release spring and the shift interlock release. Press down on the shift interlock release until you hear a click.

NOTE: Make sure that the slots on the release align with the corresponding grooves on the shift lever assembly.

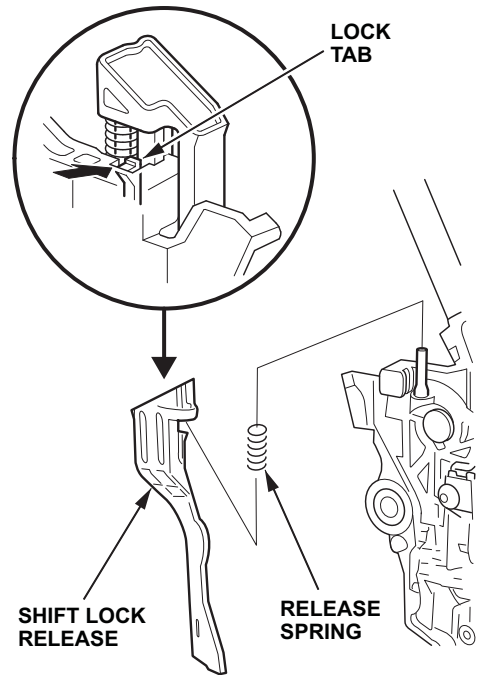

21. Press the shift interlock release button down, then release it. Check that the shift interlock release returns to its original position without sticking or binding.

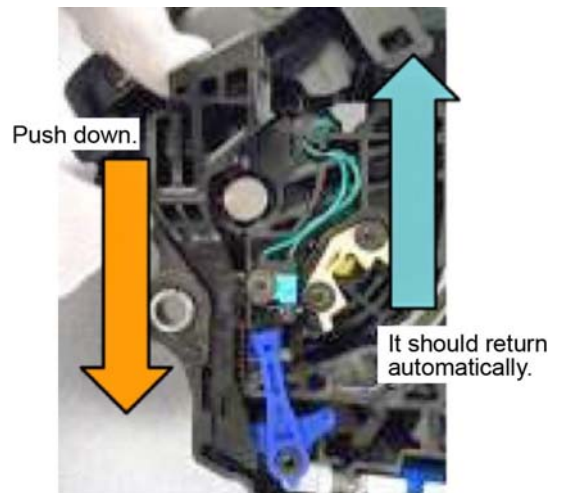

22. Move the shift lever to N.

23. Reinstall the PRNDL trim.

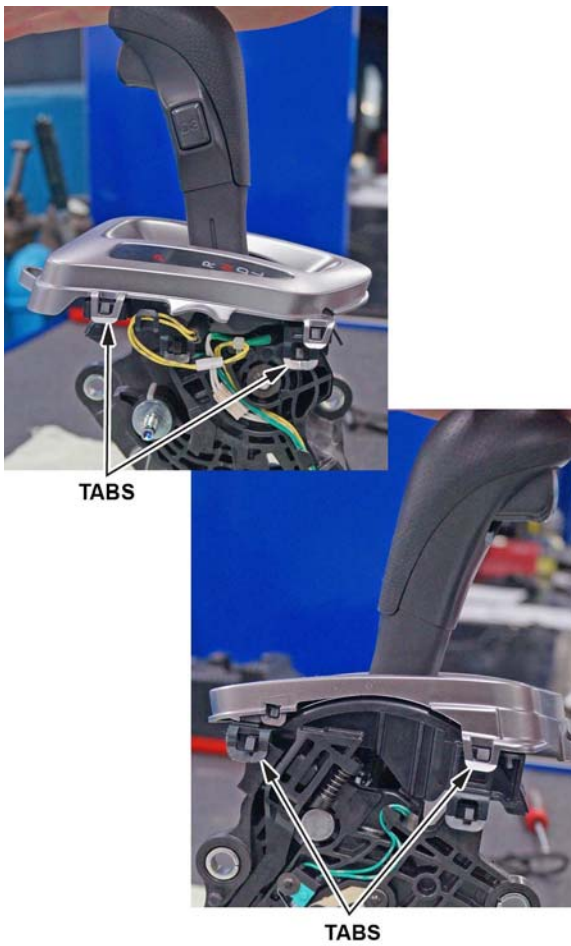

24. Make sure you can move the shift lever easily into each gear position. Press the shift interlock release to move the shift lever out of P.



25. Make sure the green wires are properly routed and set in the cavity as shown.



26. Reinstall the shift lever assembly.

- Set the shift lever assembly into the instrument panel, then install and finger-tighten the two bolts and nut.

- Move the shift lever to R.
- Lock the shift lever in R by inserting the pin (6 mm diameter) into the positioning holes.
- Torque the two shift lever assembly bolts and nut to **22 N·m (16 lb-ft)**.
- Connect the shift lever connector.

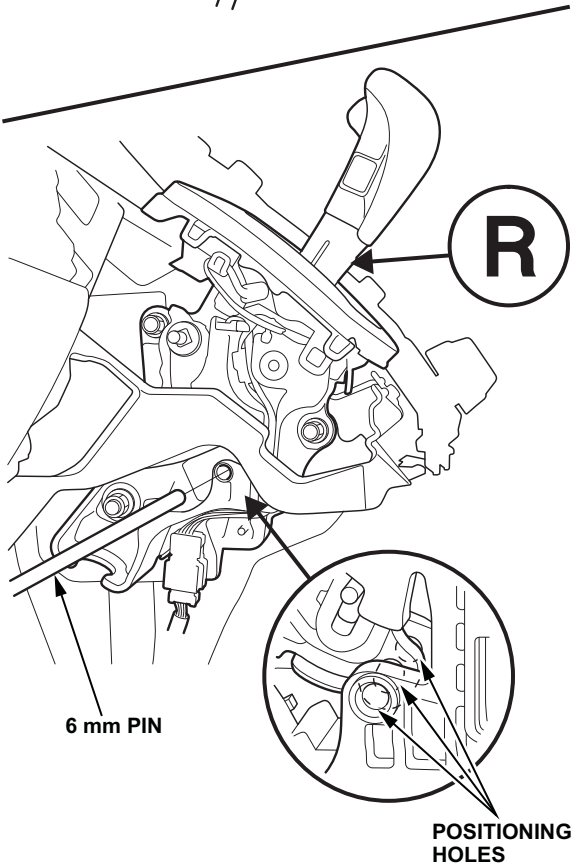
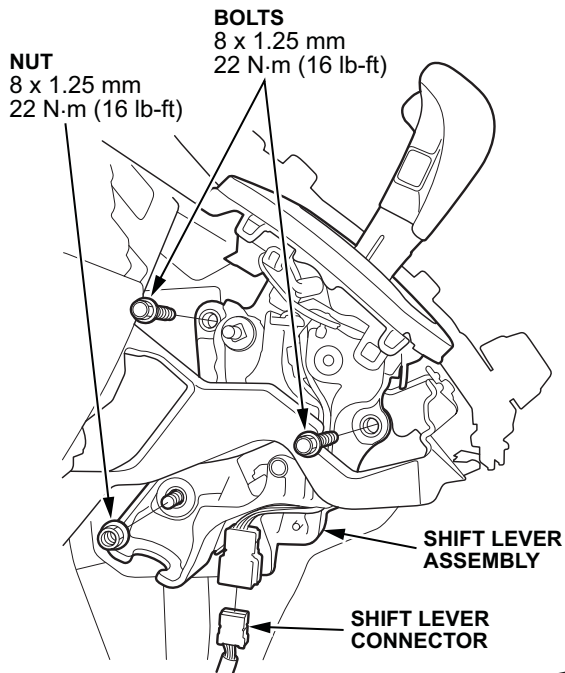

27. Reinstall the shift cable. First click on the video below to see how the step is done.



- Align the shift cable slot (located between the socket holder and the retainer lock) with the opening of the shift cable bracket.

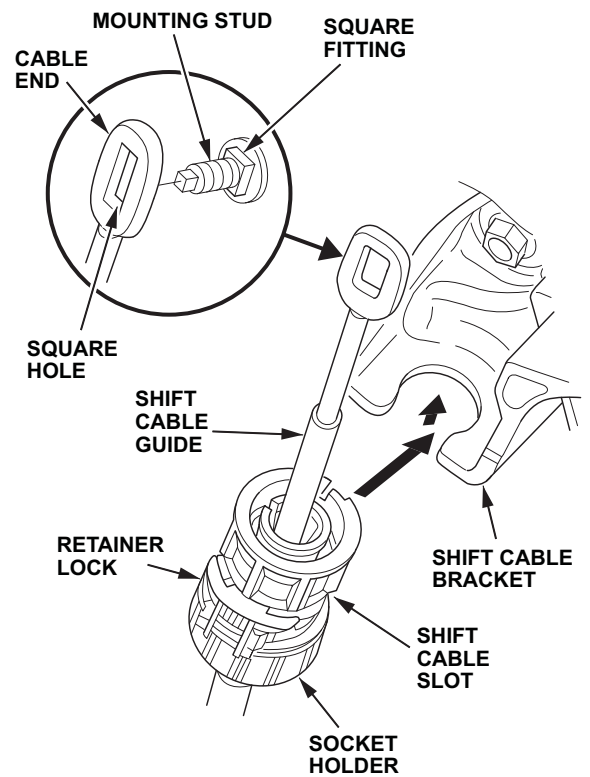

- Slide the socket holder onto the shift cable bracket while installing the shift cable end onto the mounting stud by aligning the square hole with the square fitting at the bottom of the stud.

**NOTE:**

- Do not install the shift cable by holding the shift cable guide, or the guide may break. If this happens, the entire shift cable must be replaced
- When the socket holder is installed onto the shift cable bracket, the retainer lock will un hinge. When the retainer lock unhinges, the spring tension is released, securing the shift cable to the bracket.

- Push in the retainer lock to lock the socket holder retainer.

NOTE: Make sure the retainer lock fits into the hinged joint. If it does not, rotate the holder retainer counterclockwise while pushing the retainer lock until it locks.

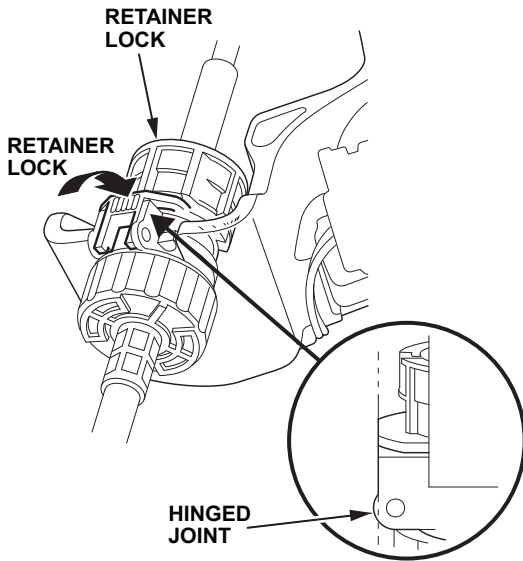

- Check that the shift cable end is properly installed on the mounting stud.

NOTE:

- If the cable end is not properly installed, remove the socket holder and align the cable end over the stud before installing the holder retainer to the shift cable bracket.
- Do not try to bend the cable to align the cable end over the mounting stud without removing the retainer holder.

- You can rotate the mounting stud so that the shift cable end fits on the square fitting at the bottom of the stud.

**PROPERLY INSTALLED:**

Cable end rides on the bottom of the mounting stud.

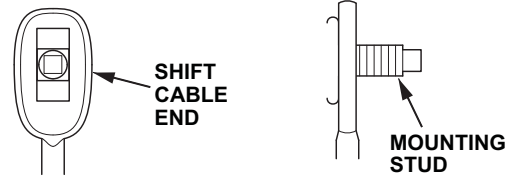

**IMPROPERLY INSTALLED:**

Cable end out of position with the mounting stud.



**IMPROPERLY INSTALLED:**

Cable end out of alignment with the mounting stud.

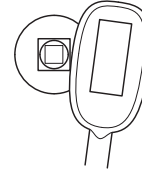

28. Reinstall the nut on the shift cable end and torque it to **22 N•m (16 lb-ft)**.

**SHIFT CABLE**

**END NUT**

22 N•m (16 lb-ft)

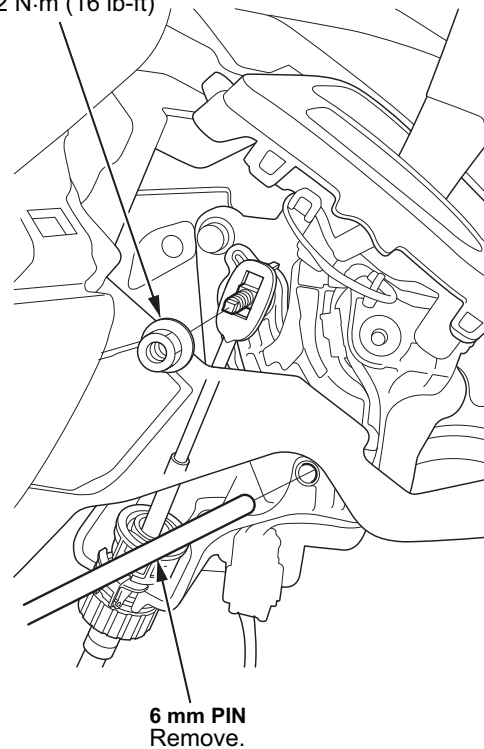

6 mm PIN  
Remove.



29. Remove the pin.
30. Turn the ignition switch to ON (II), and make sure the R position indicator in the instrument panel is on.

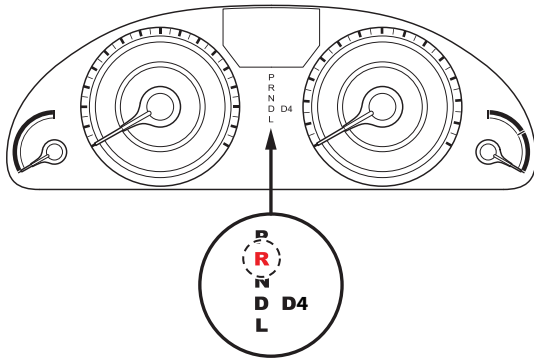

31. Move the shift lever to P.
32. Press and hold the brake pedal and move the shift lever to each gear position, making sure the A/T gear position indicator matches the position of the transmission range switch in the dash.
33. Move the shift lever to P and release the brake pedal.
34. Make sure the shift interlock works properly:
  - Try to move the shift lever out of P without touching the brake pedal. It should not move out of P.
  - Use a key to release the shift interlock and move the shift lever out of P without touching the brake pedal. You should be able to move the shift lever out of P and into the other positions. Move the shift lever back to P and confirm it locks.
35. Turn the ignition switch to LOCK (0).
36. Reinstall the center lower console.
37. Reinstall the passenger's middle panel.
38. Reinstall the passenger's dashboard side lid.
39. Reinstall the center middle panel.
40. Reinstall the driver's and passenger's heater panels.

**Example of Customer Letter**

May 2013

**Safety Recall: 2012–13 Odyssey Shift Interlock Stopper – NHTSA Recall 13V-143**

Dear Honda Odyssey Owner:

This notice is sent to you in accordance with the requirements of the National Traffic and Motor Vehicle Safety Act.

**What is the reason for this notice?**

Honda has decided that certain 2012–13 model year Odyssey vehicles fail to conform to the requirements of the portion of Federal Motor Vehicle Safety standard No. 114, "Brake Transmission shift Interlock". There is a potential that at sub-freezing temperatures the brake shift interlock blocking mechanism could allow the automatic transmission gear selector lever to be moved from the Park position without pressing the brake pedal, which could cause the vehicle to roll away, increasing the risk of a crash.

**What should you do?**

Call any authorized Honda dealer and make an appointment to have the automatic transmission gear selector lever repaired at no cost to you. The complete replacement process may take approximately 42 minutes; however, your vehicle will need to be at the dealer for a longer period of time. We recommend that you plan to leave your vehicle for half a day to allow the dealer flexibility in scheduling.

**Who to contact if you experience problems?**

If you are not satisfied with the service you receive from your Honda dealer, you may write to:

American Honda Motor Co., Inc.  
Honda Automobile Customer Service  
Mail Stop 500-2N-7A  
1919 Torrance Blvd.  
Torrance, CA 90501-2746

If you believe that American Honda or the dealer has failed or is unable to remedy the noncompliance in your vehicle, without charge, within a reasonable period of time (60 days from the date you first contact the dealer for a repair appointment), you may submit a complaint to:

Administrator  
National Highway Traffic Safety Administration  
1200 New Jersey Ave., SE  
Washington, DC 20590

Or call the toll-free Safety Hotline at 1-888-327-4236 (TTY 1-800-424-9153), or go to <http://www.safercar.gov>.



**What to do if you feel this notice is in error**

Registration records indicate that you are the current owner or lessee of a 2012–13 Honda Odyssey involved in this campaign. If this is not the case, or the name/ address information is not correct, please complete and sign the Information Change Card and return it in the enclosed postage-paid envelope. We will then update our records.

**Lessor Information**

Federal law requires that any vehicle lessor receiving this recall notice must forward a copy of this notice to the lessee within 10 days.

**If you have questions**

If you have any questions about this notice, or need assistance with locating a Honda dealer, please call Honda Automobile Customer Service at 800-999-1009, and select option 4. U.S. customers can also locate a dealer online at *Hondacars.com*. Customers in U.S. territories, please contact your local dealer/distributor.

We apologize for any inconvenience this campaign may cause you.

Sincerely,

**American Honda Motor Co., Inc.**  
**Honda Automobile Division**