



## Safety Recall: 2012-13 CR-V Shift Interlock Stopper (Supersedes 13-035, dated April 12, 2013; see REVISION SUMMARY)

### REVISION SUMMARY

Under REPAIR PROCEDURE, all artwork is now final.

### BACKGROUND

In sub-freezing temperatures, it is possible to move the shift lever out of P without pressing the brake pedal.

### CUSTOMER NOTIFICATION

Owners of affected vehicles will receive a notification of this campaign.

Do an **iN VIN status inquiry** to make sure the vehicle is shown as eligible.

Some vehicles affected by this campaign may be in your new or used vehicle inventory. These vehicles **must** be repaired before they are sold.

Should your dealership sell an unrepaired vehicle that subsequently causes injury or damage because of the recalled item, the dealership will be solely responsible to the damaged party, and will be required to defend and indemnify American Honda for any resulting claims. To see if a vehicle in inventory is affected by this recall, do a VIN status inquiry before selling it.

### CORRECTIVE ACTION

Replace the shift interlock stopper.

### PARTS INFORMATION

Shift Interlock Stopper: P/N 06540-T0A-A81

### TOOL INFORMATION

KTC Trim Tool Set: T/N SOJATP2014

Snap-On Pick Tool (or equivalent): T/N SG3ASH90B

### WARRANTY CLAIM INFORMATION

Operation Number: 2151C9

Flat Rate Time: 0.6 hour

Failed Part: P/N 54123-SLE-J51

Defect Code: 5GU00

Symptom Code: S9600

Skill Level: Repair Technician

### REPAIR PROCEDURE

1. Carefully pry out the shift lever panel with the appropriate trim tool to detach the clips and the hooks, then remove the shift lever panel.

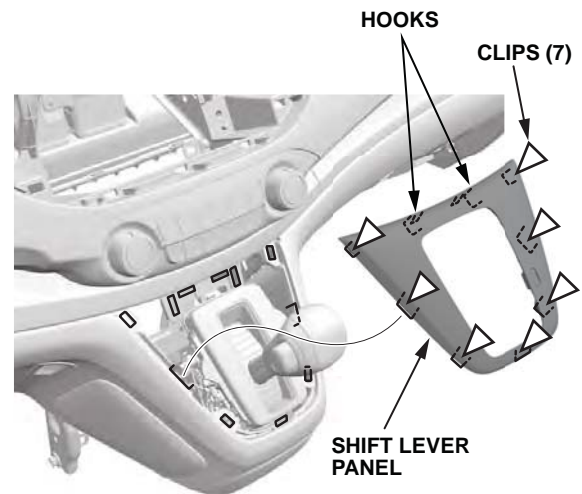

2. Slide the driver's seat all the way rearward.

3. Remove the visible clips, then detach the hidden clips to remove the left front console cover.

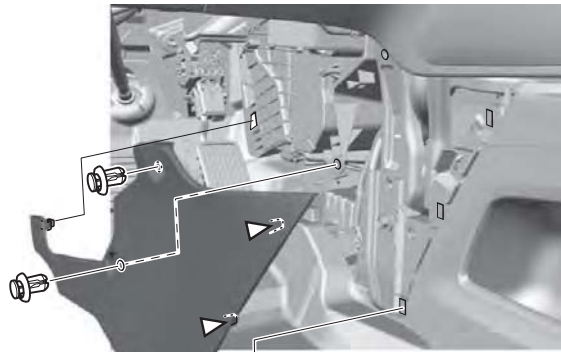

**FRONT LEFT  
CONSOLE COVER**

4. Remove the maintenance cover.

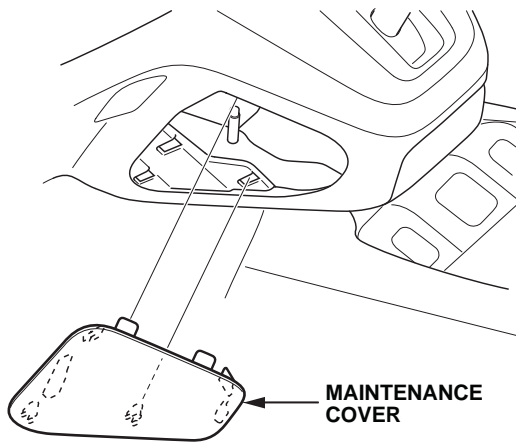

**MAINTENANCE  
COVER**

5. Make sure the parking brake is applied, then press the interlock shift button to move the shift lever to R. Move the shift lever to R, then insert a pin (6 mm diameter) into the positioning holes to lock the shift lever assembly in R.

**NOTE:** Make sure there are no burrs on the pin.

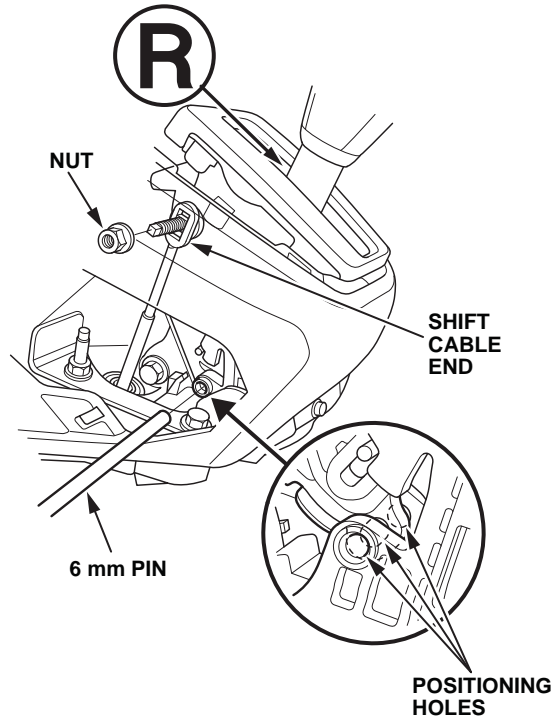

6. Remove the nut securing the shift cable end.

7. Release the tab that secures the two connectors to the console box assembly.



RELEASE TAB

8. Remove the shift cable from the shift cable bracket.

NOTE: The dashboard brackets may have sharp edges. Wear gloves to protect your hands.

- Release the retainer lock.

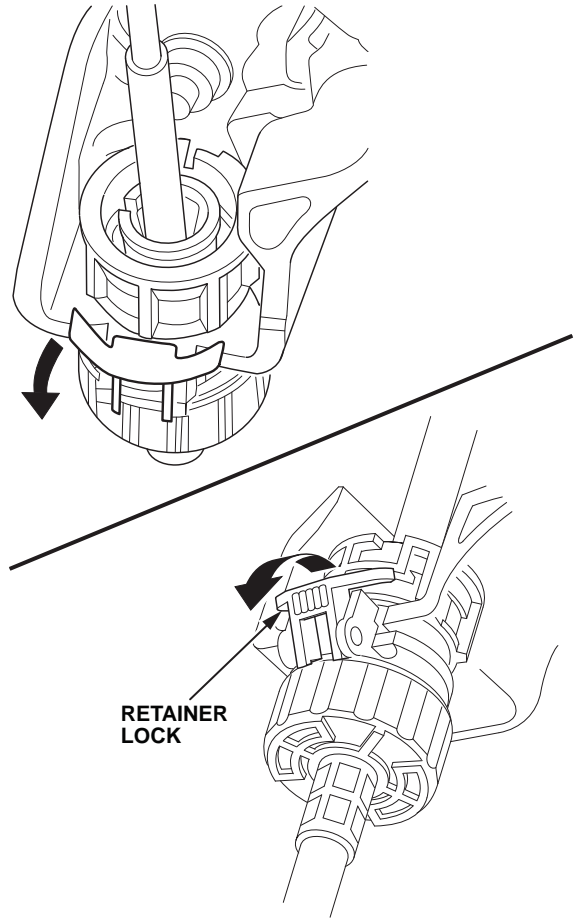

- Rotate the upper half (above the retainer lock) of the socket holder retainer counterclockwise until it stops turning.

SOCKET HOLDER  
RETAINER

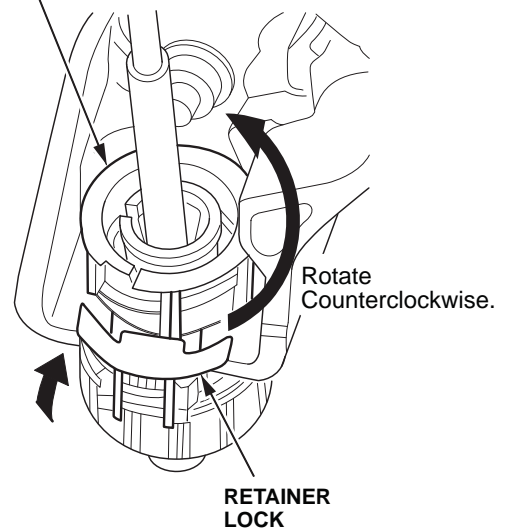

- Once the retainer stops rotating, push the retainer lock into the socket holder retainer to lock the socket holder retainer in place.

**NOTE:**

- Make sure the retainer lock properly locks the retainer because the retainer is spring loaded and will release if let go. If it does release, reset it by rotating the upper half of the socket holder.
- Do not rotate the lower half of the socket holder retainer (below the retainer lock), or it may break.

- Remove the shift cable by holding the socket holder retainer and sliding it off of the shift cable bracket.

**NOTE:** Do not remove the shift cable by pulling on the shift cable guide, or the guide may break. If this happens, the entire shift cable must be replaced.

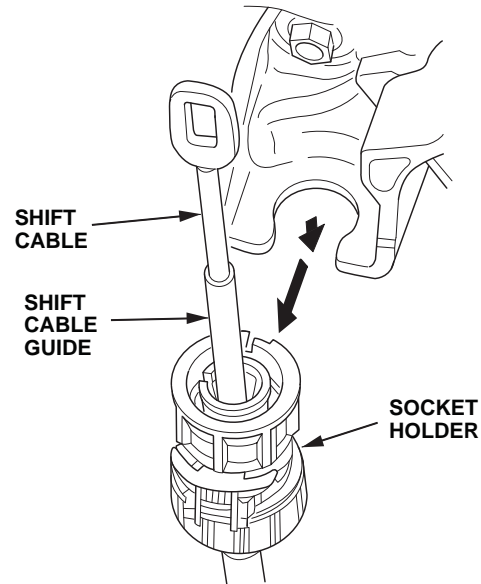

9. Disconnect the shift lever connector.

**NOTE:** Use a small screwdriver to reach inside the console to release the connector.

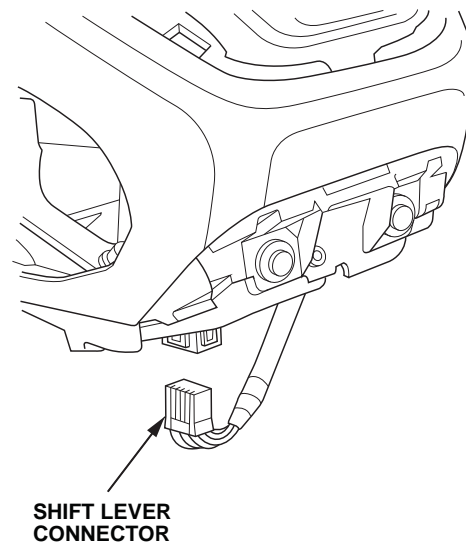

10. Remove the shift lever assembly from the instrument panel.

- Remove the three bolts from the shift lever assembly.

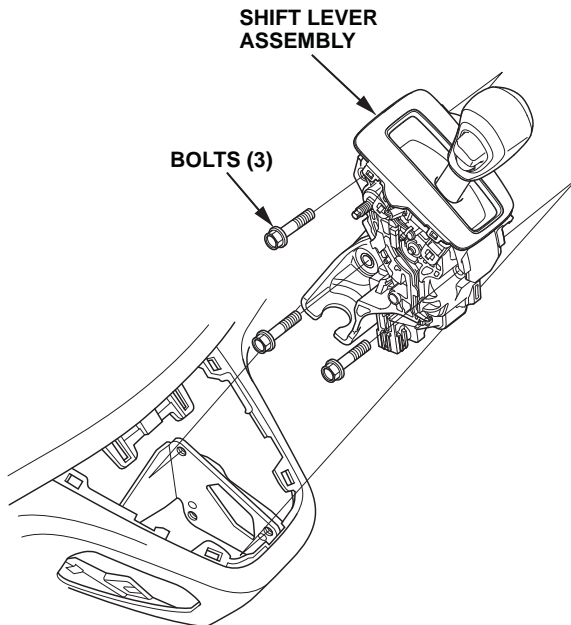

- Remove the pin (6 mm diameter) that you inserted earlier to lock the shift lever assembly in the R position.

11. Move the shift lever to N to avoid interference between the shift knob and the PRNDL trim.

NOTE: Lay the shift lever assembly on a clean cloth to prevent damaging it.



12. Move the PRNDL trim to access the shift interlock release.

- Unsnap the four tabs.

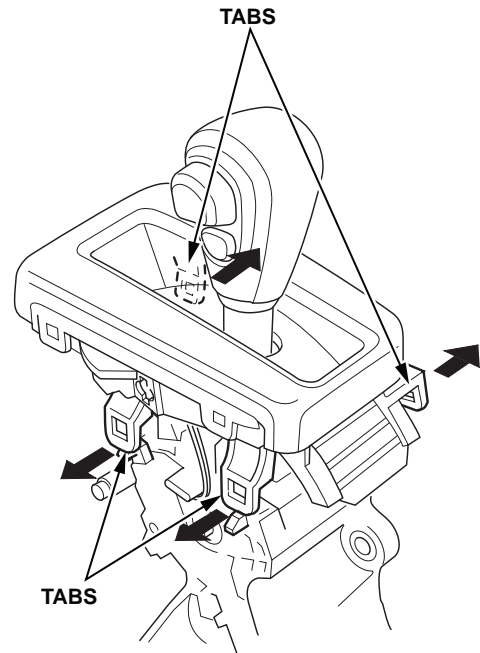

- Move the shift lever to 1.

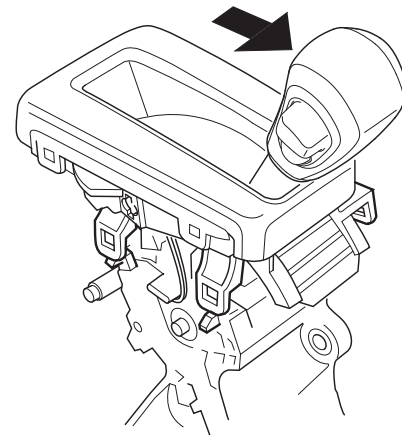

- Move the PRNDL trim down as shown.

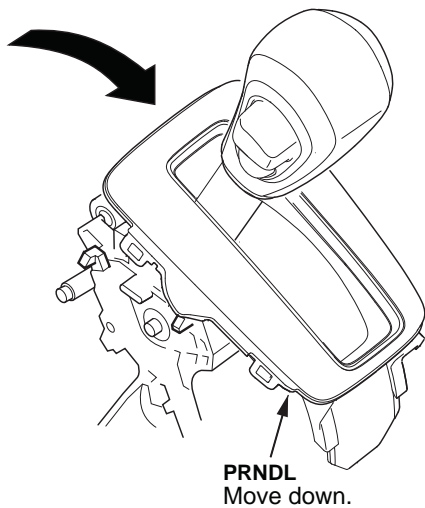

13. Release the shift interlock release by using a pick tool or small flat blade screwdriver (3 mm diameter) to push the tab down and in toward the shift interlock release.

**SHIFT LOCK RELEASE**



14. After unlocking the tab, lay the shift lever assembly on its side, and remove the shift interlock release and spring.

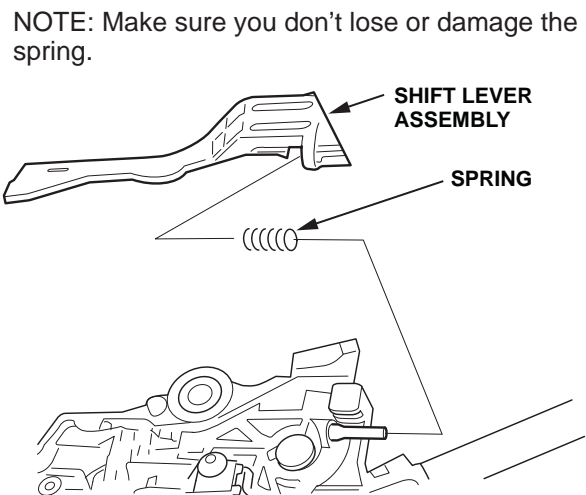

15. Remove the shift interlock solenoid.

- Insert a small screwdriver into the rectangular opening for the shift interlock solenoid tab.

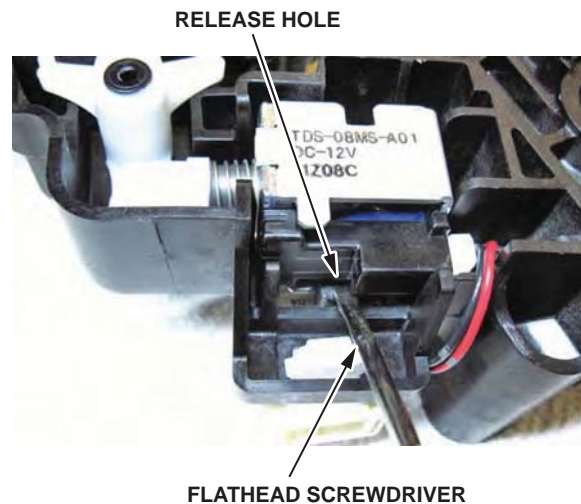

- Move the screwdriver handle down as shown to release the solenoid tab and pry up the solenoid.

- Remove the shift interlock solenoid from the shift lever assembly and lay it down next to the assembly. Do not disconnect the connector.

NOTE: The solenoid plunger and its spring can fall out of the solenoid. If this happens, reassemble the shift interlock solenoid before setting it down.

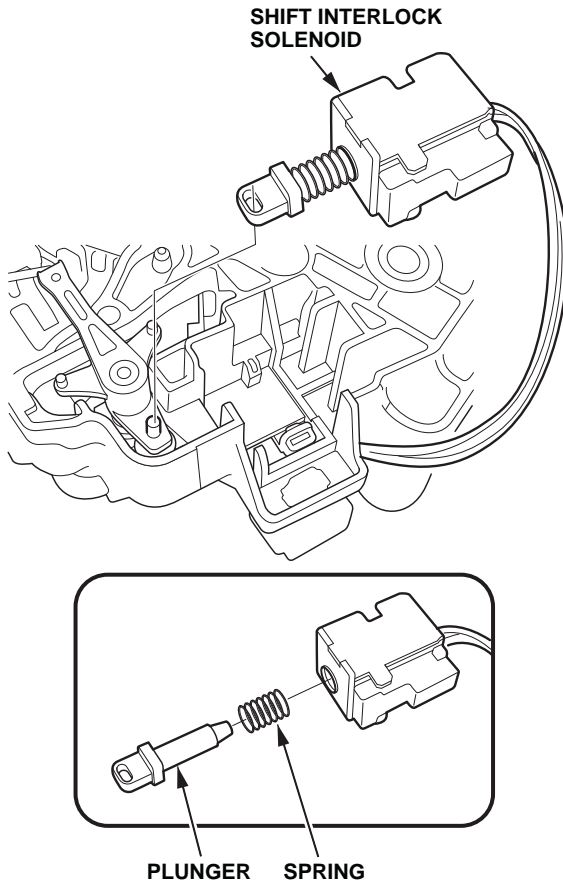

- Remove the white shift interlock stopper from the shift lever assembly.

NOTE: Do not wipe the grease from the shift lever assembly.

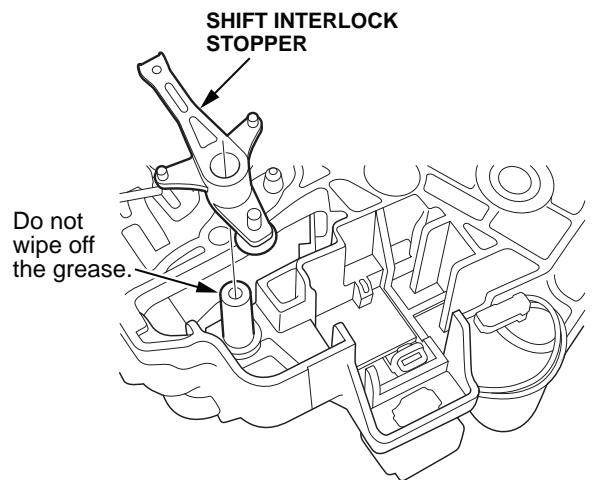

- Install the new (blue) shift interlock stopper.

NOTE: Do not wipe the grease off the new shift interlock stopper.

> Shift Interlock Stopper

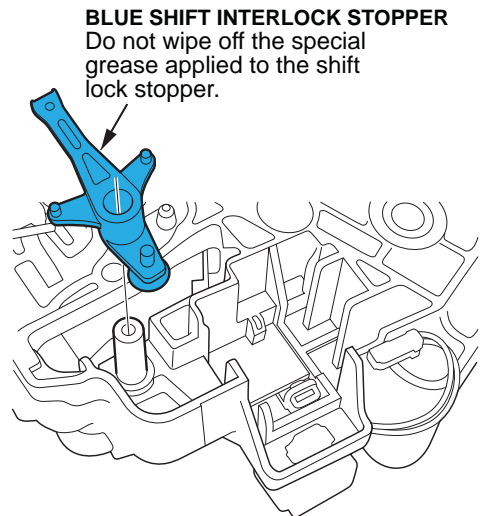

18. Reinstall the shift interlock solenoid by aligning the solenoid plunger joint with the tip of the shift interlock stopper, then push down on the bottom area of the solenoid (side with the printing) until you hear a click.



19. Check that the shift interlock stopper and solenoid motion is smooth.

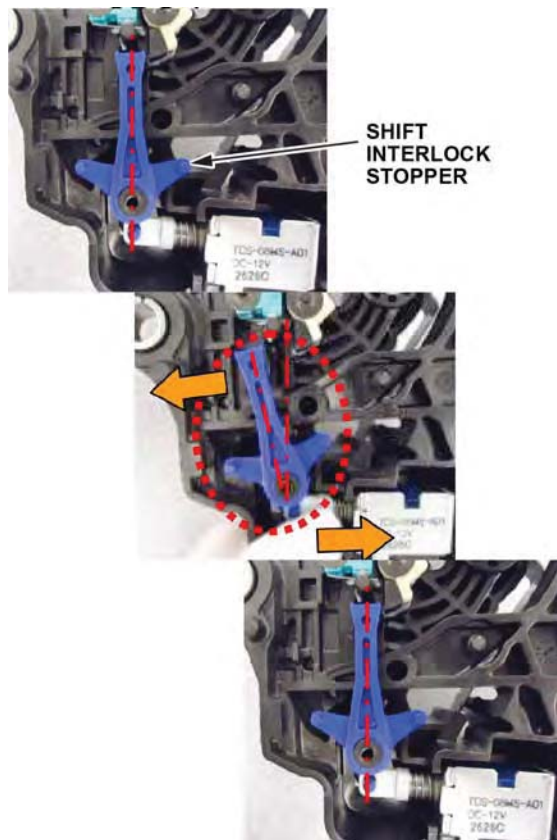



20. Reinstall the release spring and the shift interlock release. Press down on the shift interlock release until you hear a click.

NOTE: Make sure that the slots on the release align with the corresponding grooves on the shift lever assembly.

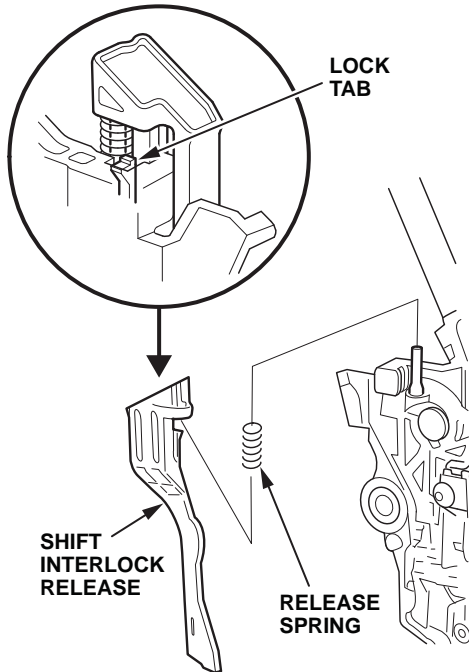

21. Press the shift interlock release button down, then release it. Make sure the shift interlock release returns to its original position without sticking or binding.

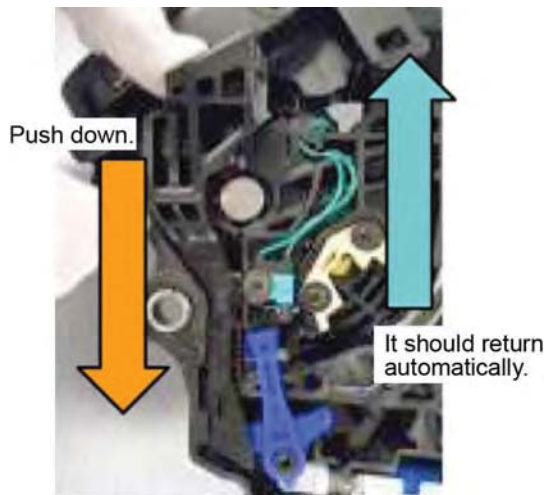

22. Move the shift lever to N.

23. Reinstall the PRNDL trim.

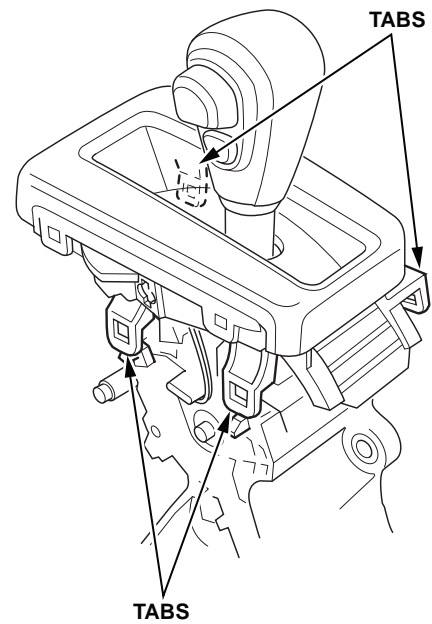

24. Make sure that you can move the shift lever easily into each gear position. Press the shift interlock release to move the shift lever out of P.



25. Make sure the green wires are properly routed and set in the cavity as shown.

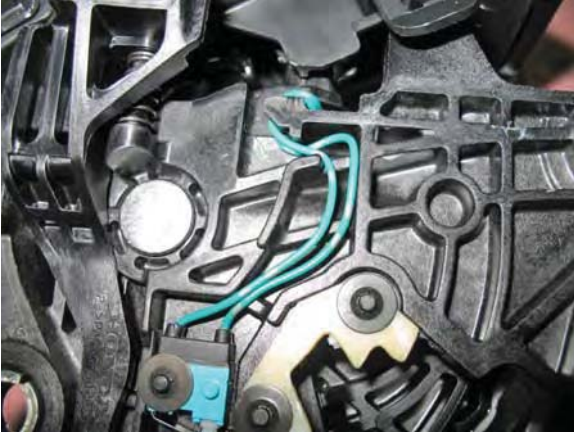

26. Reinstall the shift lever assembly.

- Set the shift lever assembly into the instrument panel, then install and finger-tighten the three bolts.

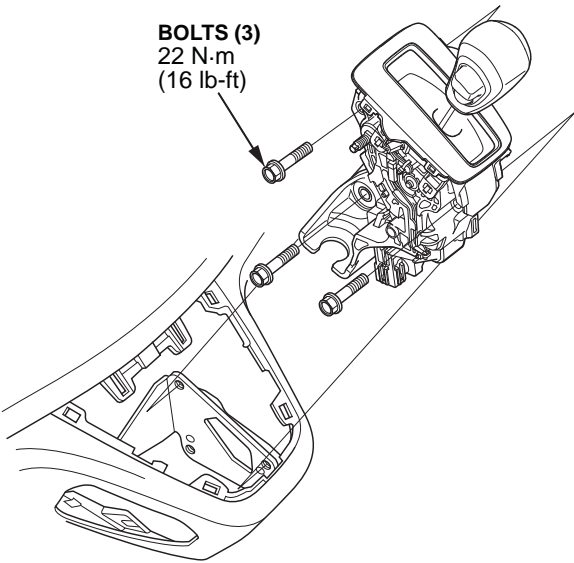

- Move the shift lever to R.
- Lock the shift lever in R by inserting the pin (6 mm diameter) into the positioning holes.

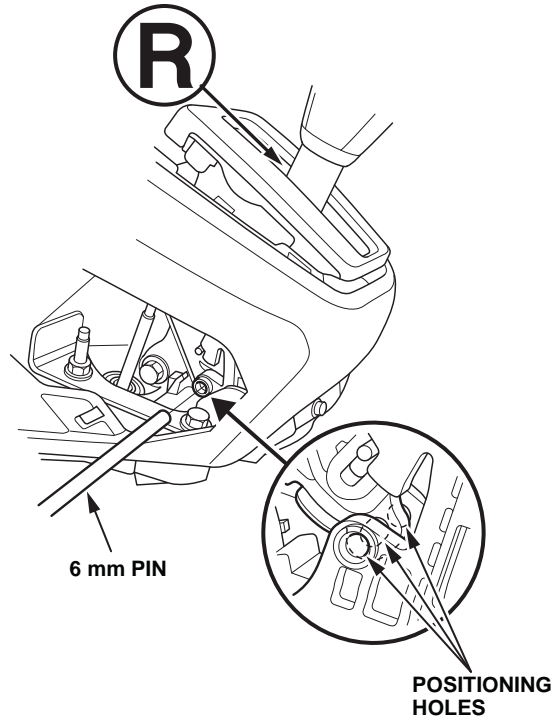

- Make sure the green wires are not pinched by inserting a zip tie (150 mm x 6 mm x 1.2 mm) as a feeler gauge between the right side of the shift lever assembly and the shift lever bracket base.
- If the zip tie moves freely between the two parts, the green wire is properly routed. Go to the next bullet.
- If the zip tie does not move smoothly between the two parts, remove one or two of the bolts, then use the wire tie to route the green wires properly, then reinstall the bolts. Check the clearance again.

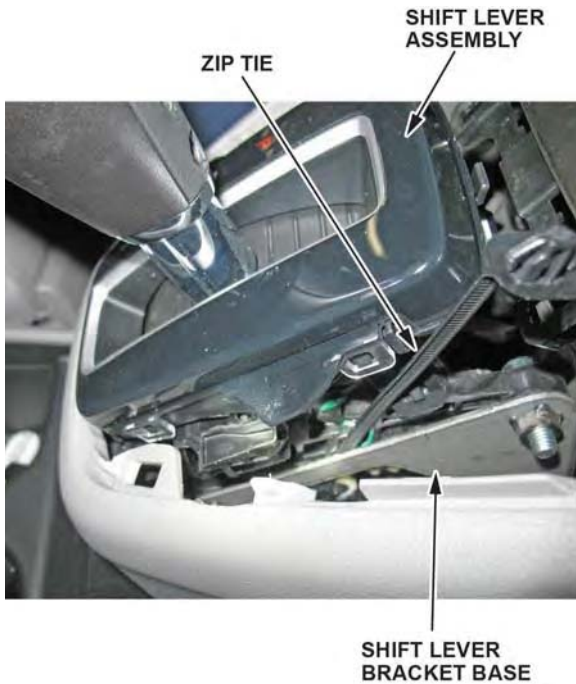

- Torque the three shift lever assembly bolts to **22 N•m (16 lb-ft)**.

27. Reconnect the shift lever connector.

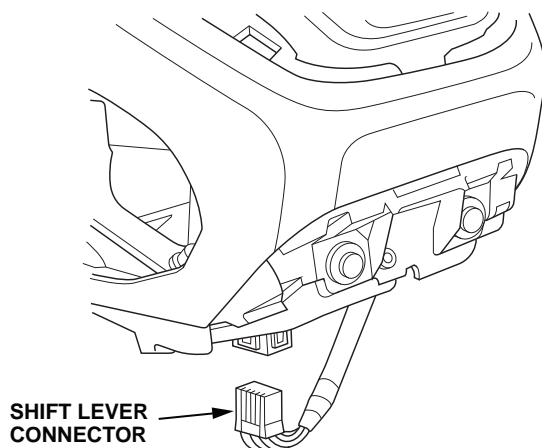

28. Reinstall the shift cable.

- Align the shift cable slot (located between the socket holder and the socket holder retainer) with the opening of the shift cable bracket.

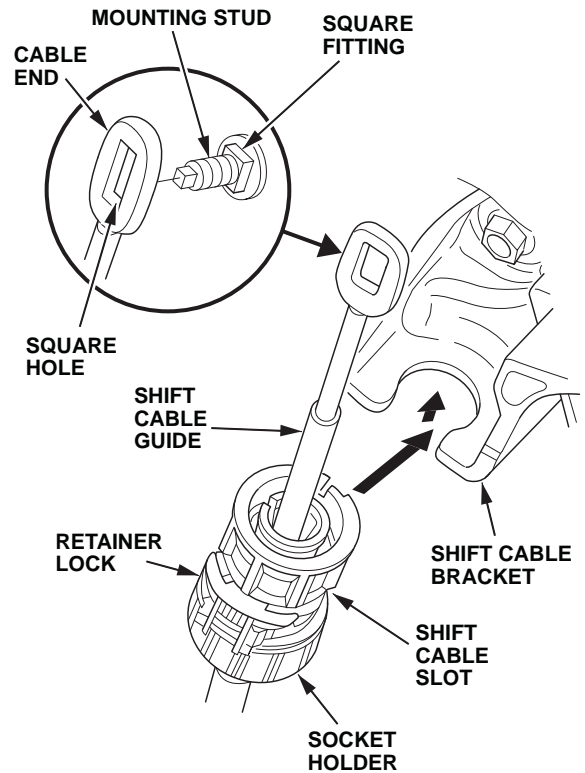

- Slide the socket holder onto the shift cable bracket while installing the shift cable end onto the mounting stud by aligning the square hole with the square fitting at the bottom of the stud.

NOTE:

- Do not install the shift cable by holding the shift cable guide, or the guide may break. If this happens, the entire shift cable must be replaced
- When the socket holder is installed onto the shift cable bracket, the retainer lock will unhinge. When the retainer lock unhinges, the spring tension is released, securing the shift cable to the bracket.

- Push in the retainer lock to lock the socket holder retainer.

NOTE: Make sure the retainer lock fits into the hinged joint. If it does not, rotate the holder retainer counterclockwise while pushing the retainer lock until it locks.

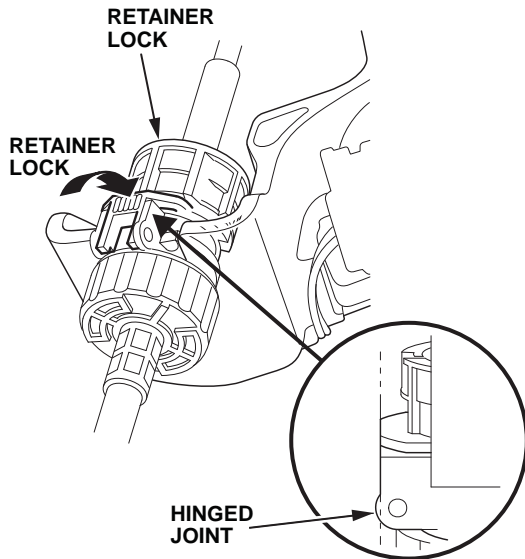

- Make sure the shift cable end is properly installed on the mounting stud.

NOTE:

- If the cable end is not properly installed, remove the socket holder and align the cable end over the stud before installing the holder retainer to the shift cable bracket.
- Do not try to bend the cable to align the cable end over the mounting stud without removing the retainer holder.
- You can rotate the mounting stud so that the shift cable end fits on the square fitting at the bottom of the stud.

**PROPERLY INSTALLED:**

Cable end rides on the bottom of the mounting stud.

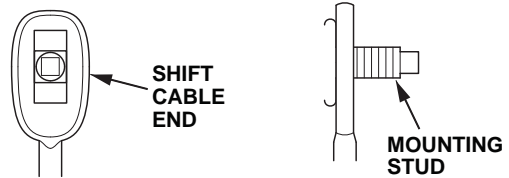

**IMPROPERLY INSTALLED:**

Cable end out of position with the mounting stud.



**IMPROPERLY INSTALLED:**

Cable end out of alignment with the mounting stud.

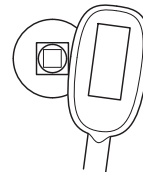

29. Reinstall the nut on the shift cable end and torque it to **22 N•m (16 lb-ft)**.

**SHIFT CABLE  
END NUT**  
22 N•m (16 lb-ft)

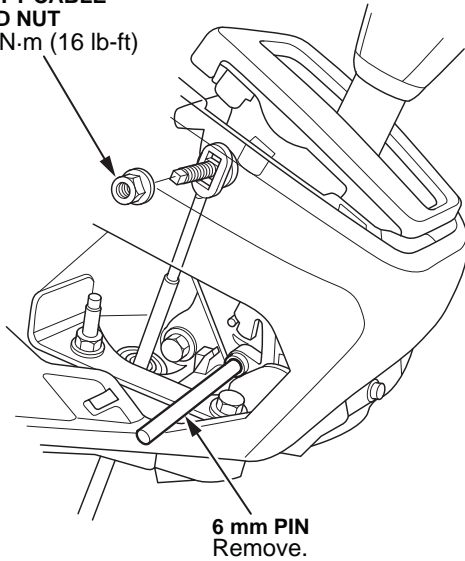

30. Remove the pin.
31. Turn the ignition switch to ON (II), and make sure that the R position indicator in the instrument panel is on.

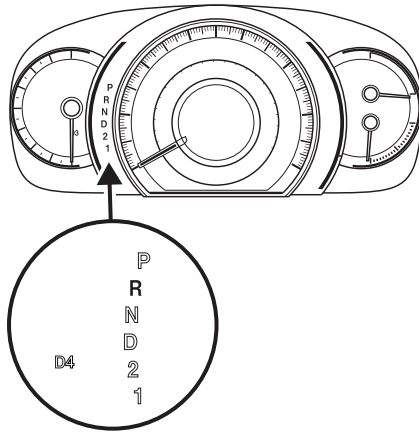

32. Move the shift lever to P.
33. Press and hold the brake pedal and move the shift lever to each gear position, making sure the A/T gear position indicator matches the position of the transmission range switch in the instrument panel.
34. Move the shift lever to P and release the brake pedal.

35. Make sure the shift interlock works properly:

- Try to move the shift lever out of P without touching the brake pedal. It should not move out of P.
- Use a key to release the shift interlock and move the shift lever out of P without touching the brake pedal. You should be able to move the shift lever out of P and into the other positions. Move the shift lever back to P and confirm it locks.

36. Turn the ignition switch to LOCK (0).

37. Reinstall the maintenance cover.

38. Reinstall the left front console cover.

39. Reinstall the shift lever panel.