



Applies To: **2005–06 MDX** – Check the iN VIN status for eligibility
2005 RL – Check the iN VIN status for eligibility

August 26, 2016

Safety Recall: VSA System Unexpectedly Activates

Supersedes 13-013, dated July 3, 2013, to revise the information highlighted in **yellow**

REVISION SUMMARY

Templates were added under the **WARRANTY CLAIM INFORMATION**.

BACKGROUND

Damage to an internal VSA modulator-control unit component could cause the VSA system to misinterpret the signal and may cause the VSA braking system to unexpectedly apply braking force even if the driver has not pressed the brake pedal. If the brakes are applied unexpectedly, it may increase the risk of a crash.

CLIENT NOTIFICATION

Owners of affected vehicles were sent a notification of this campaign in April 2013. An example of the client notification is attached to this service bulletin.

Do an **iN VIN status inquiry** to make sure the vehicle is shown as eligible.

Some vehicles affected by this campaign may be in your used vehicle inventory. These vehicles must be repaired before they are sold.

Should a dealership sell an unrepaired vehicle that subsequently causes an injury or damage because of the recalled item, the dealership will be solely responsible to the damaged party, and will be required to defend and indemnify American Honda for any resulting claims. To see if a vehicle in inventory is affected by this campaign, do a VIN status inquiry before selling it.

CORRECTIVE ACTION

Install a VSA subharness on all vehicles.

PARTS INFORMATION

MDX VSA Subharness: P/N 06326-SFE-000

Includes:

Subharness with Capacitor

Wire Ties (4)

3P Short Connector

SUBHARNESS WITH CAPACITOR

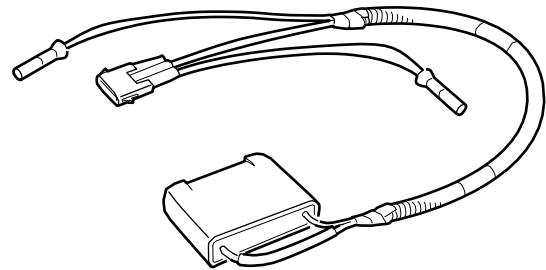

3P SHORT CONNECTOR



WIRE TIES

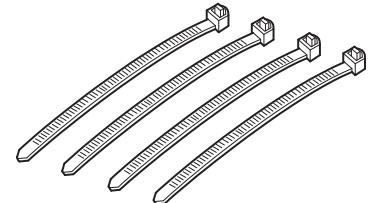

RL VSA Subharness: P/N 06326-SJK-000

Includes:

- Subharness with Capacitor
- Wire Ties (2)
- 3P Short Connector

SUBHARNESS WITH CAPACITOR

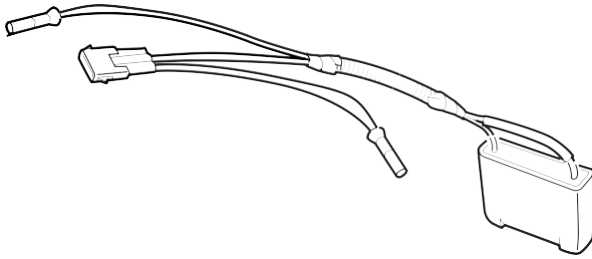

3P SHORT CONNECTOR



WIRE TIES

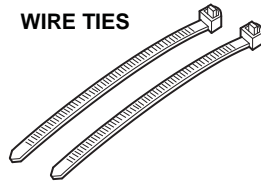

TOOL INFORMATION

Service Tool Pack 1: T/N 06324-SFE-000

Includes:

- Lance Release Housing
- Lance Release Tool
- Extra Wire Ties

NOTE:

- The lance release housing should only be used 10 times before replacing it by ordering a new service tool pack.
- Order replacements for Service Tool Pack 1 through normal parts ordering.

LANCE RELEASE HOUSING

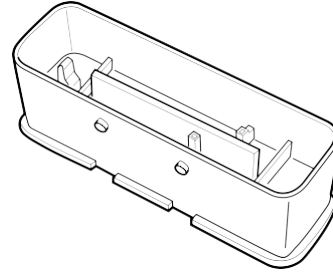

LANCE RELEASE TOOL

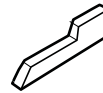

WIRE TIES

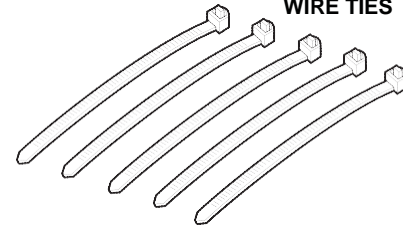

Service Tool Pack 2: 06325-SFE-000

Includes:

- Cavity Plug Remover

NOTE: Each dealership received a Service Tool Pack 2. Use the tool number if you need to order replacements; your dealership is responsible for the costs.

CAVITY PLUG REMOVER

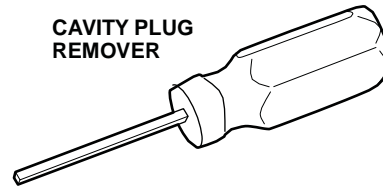

(NOT USED)

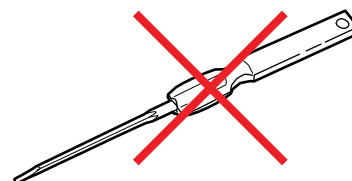

WARRANTY CLAIM INFORMATION

NOTE: Service Tool Pack 1 can be used to repair 10 vehicles. Under the **Materials Information** section of the claim template, enter a value of \$1.63 to cover the cost of Service Tool Pack 1.

MDX:

Operation Number: 7370D2

Flat Rate Time: 0.4 hour

Failed Part: P/N 57110-S3V-A32

Defect Code: 5VU00

Symptom Code: S8900

Template ID: 13-013N

Skill Level: Repair Technician

RL:

Operation Number: 7370D2

Flat Rate Time: 0.5 hour

Failed Part: P/N 57110-SJA-A03

Defect Code: 5VU00

Symptom Code: S8900

Template ID: 13-013P

Skill Level: Repair Technician

REPAIR PROCEDURE – MDX

1. Turn the ignition switch to LOCK (0).
2. Remove the engine cover and the intake air duct.

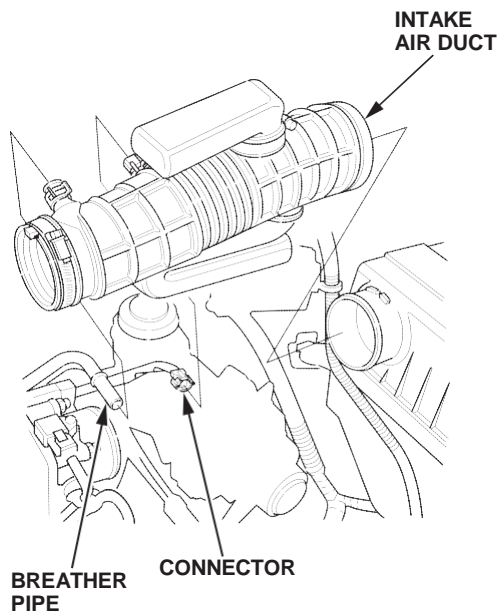

3. Disconnect the VSA modulator-control unit 47P connector.

NOTE:

- Do not force the lock because if you break it, the entire harness must be replaced. Make sure that you press the release tab before trying to move the lock. If needed, wiggle the connector while moving the lock to release the sliding mechanism in the connector.
- Disconnect the harness clips as needed to access the harness.

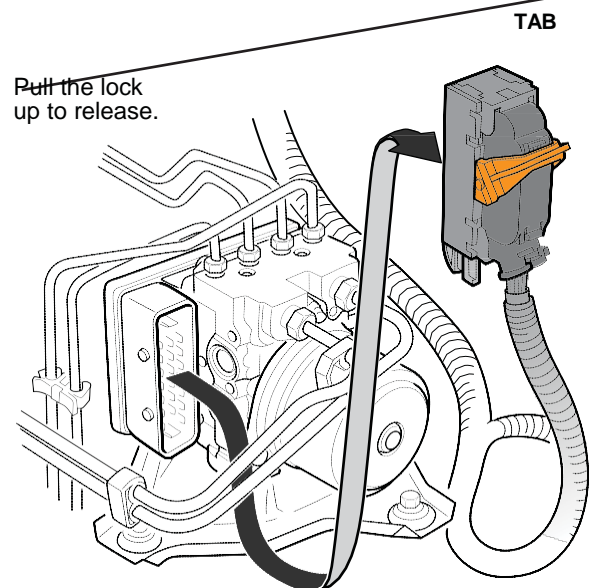
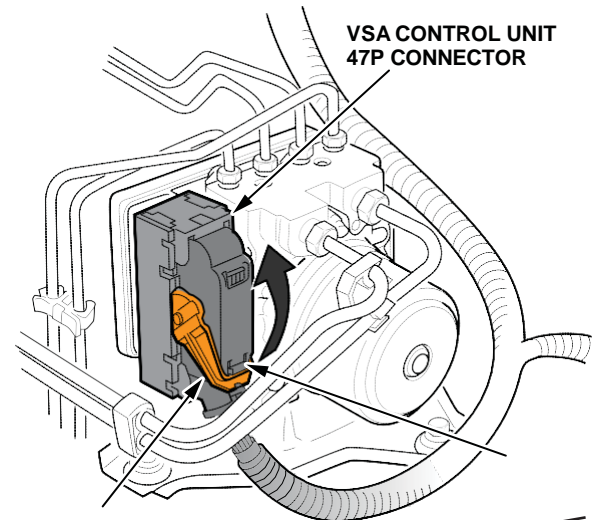

4. Insert the lance release housing into the 47P connector.

LANCE RELEASE HOUSING

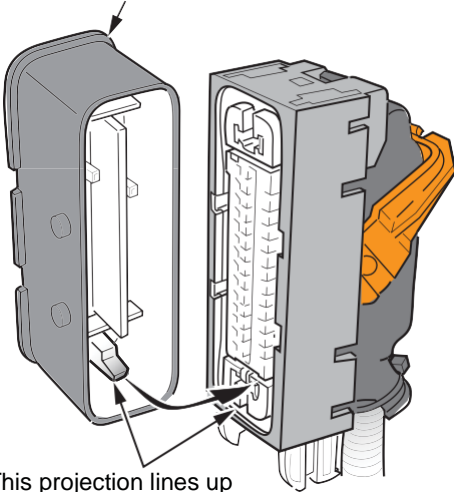

This projection lines up with the primary lock at the bottom of the connector.

5. Move the lock to the locked position. The lance release housing is fully drawn into the connector and clicks into place.

NOTE:

- Do not apply excessive force.
- If the lock sticks or will not move smoothly, return the lock to its original position, recheck the position of the lance release housing, and try again.

LANCE RELEASE HOUSING

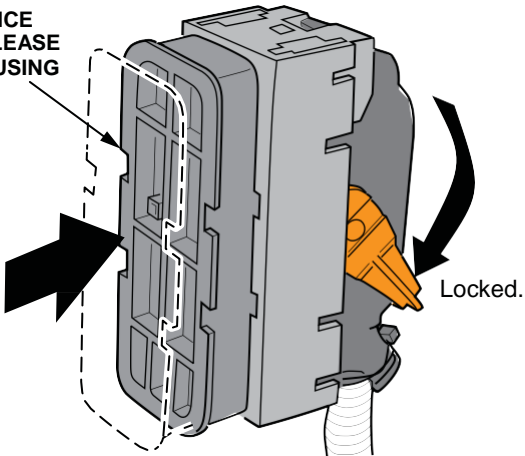

6. Use a small screwdriver to unlock and remove the lock assembly from the 47P connector.

Press to release lock assembly.

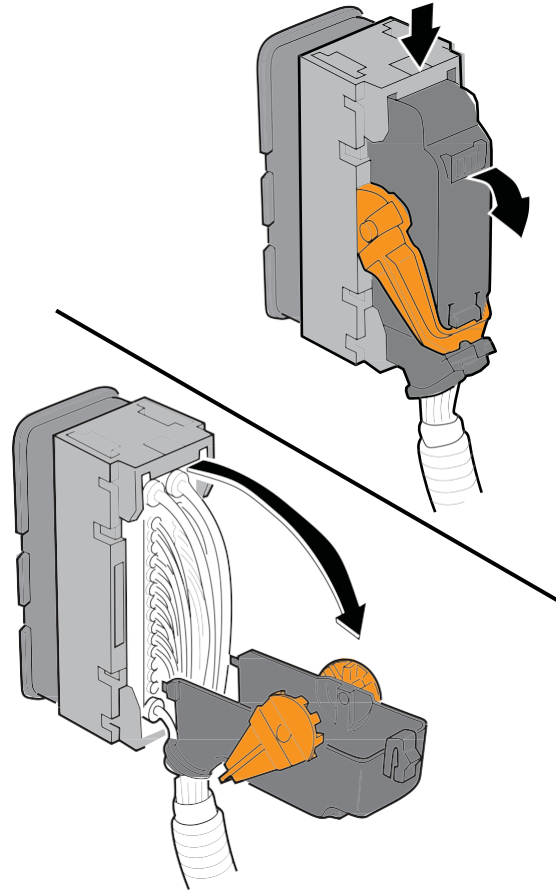

- Remove the No. 35 yellow/black wire terminal from the connector while pushing up on the lance release housing.

NOTE: Take note of the orientation of the notch in the terminal when it comes out because you'll insert the new terminal the same way.

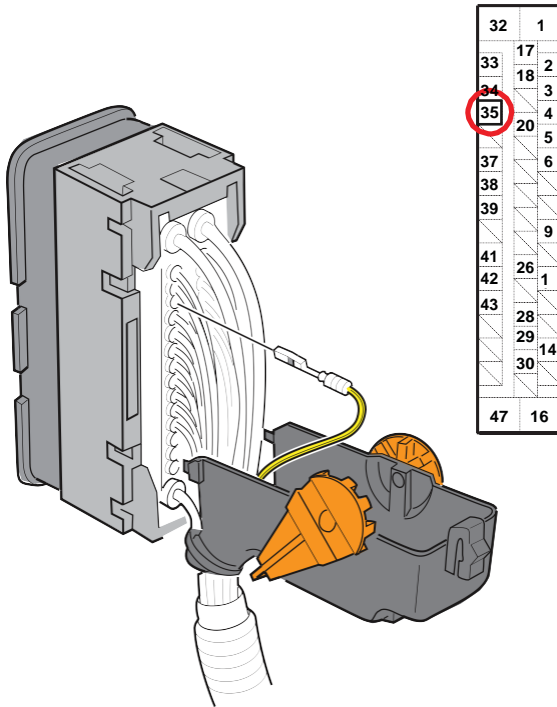

- Insert the cavity plug remover into the hole in the lance release housing as shown, and push out the plug from the No. 22 cavity.

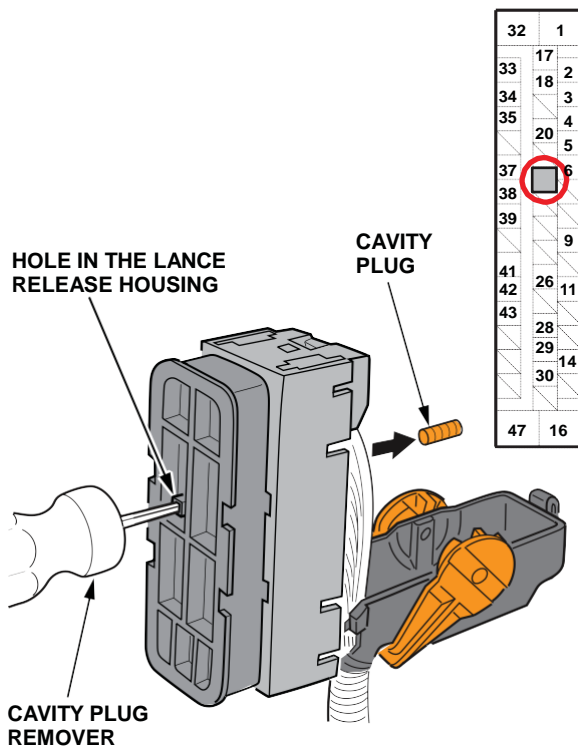

- Tuck the loose terminal and wire into the housing, then install the lock assembly onto the 47P connector as shown.

NOTE:

- Make sure the harness and the wire are not pinched.
- Make sure the lock is properly aligned.

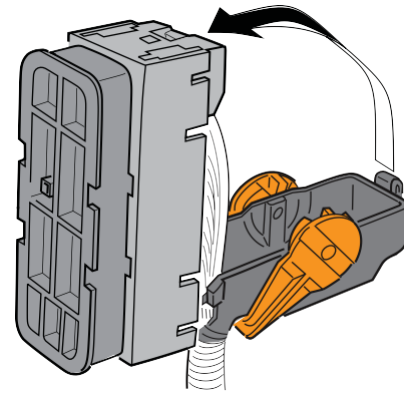

- Press the lock release tab, then move the lock to the unlocked position. The lance release housing also moves into the unlocked position.

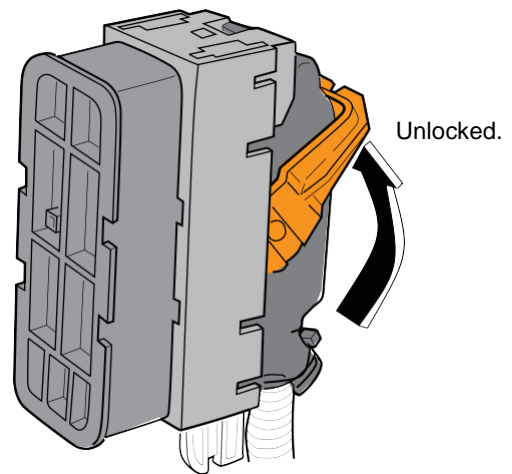

11. Using a small screwdriver, unlock and remove the lock assembly from the 47P connector.

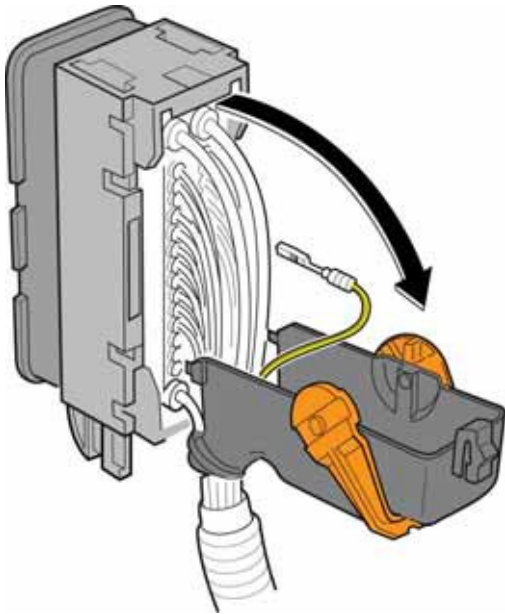

12. Install the VSA subharness.

> Subharness with Capacitor

NOTE:

- Make sure the terminal and connector are properly oriented; the notched part of the terminal should be aligned as shown.

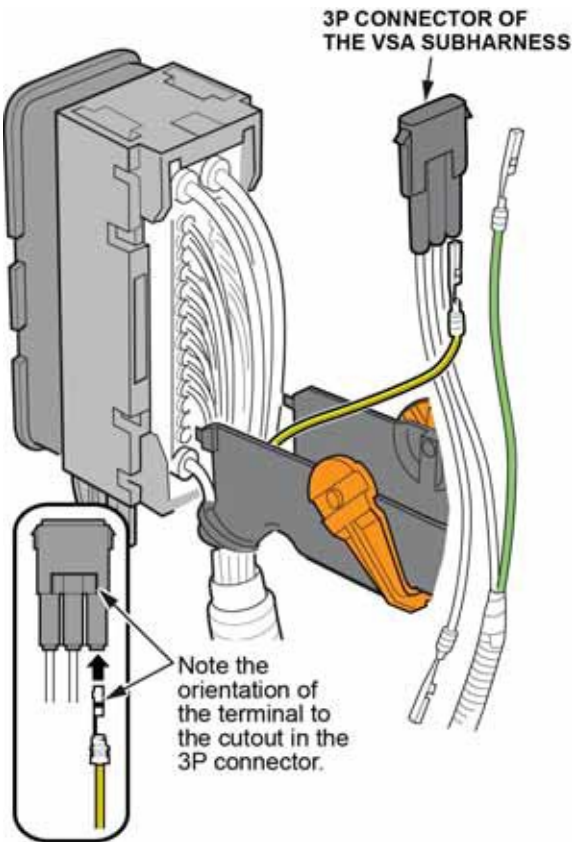

- Do not force the terminal into the connector to avoid damaging the terminals.
- You may hear a click when the terminal is seated in the 3P connector.
- After inserting the terminal into the 3P connector, gently pull on the wire to make sure it is locked into place.
- Insert the yellow/black wire terminal that was removed from cavity No. 35 into the 3P connector of the VSA subharness.
- Insert the VSA harness white wire into the VSA control unit 47P connector cavity No. 35.
- Insert the VSA harness green wire into the VSA control unit 47P connector cavity No. 22.

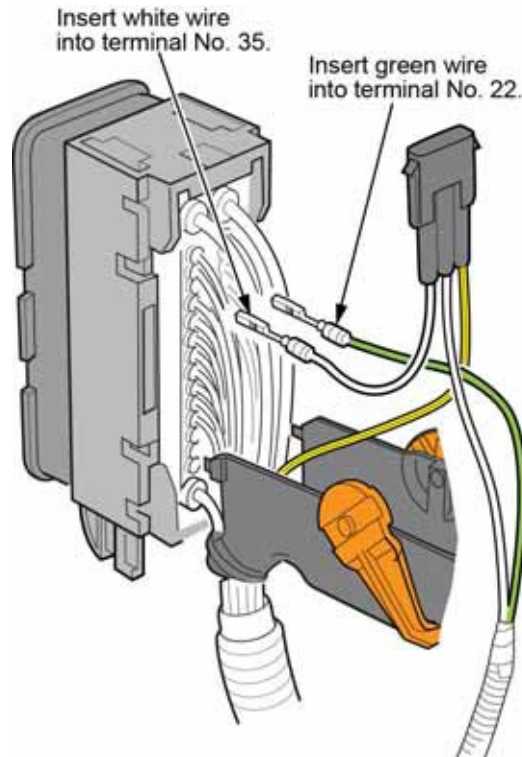

32	1
33	17
34	18
35	20
37	22
38	26
39	28
41	29
42	30
43	14
47	16

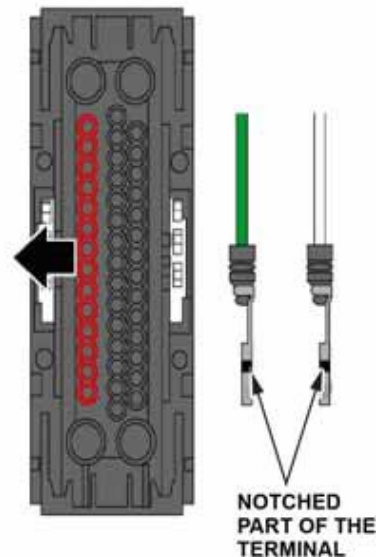

13. Install the short connector to the 3P connector.
> 3P Short Connector

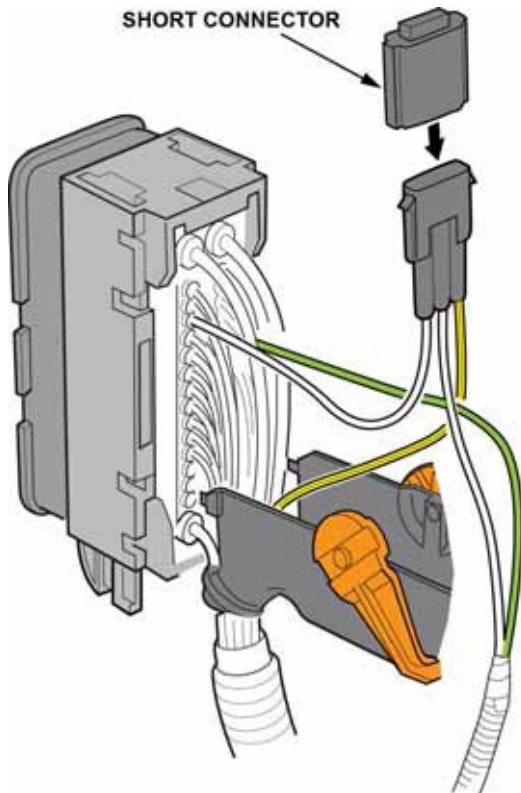

14. Lay out the subharness as shown, then install the lock assembly.

NOTE:

- Make sure the subharness is not pinched.
- Make sure the lock is properly aligned.

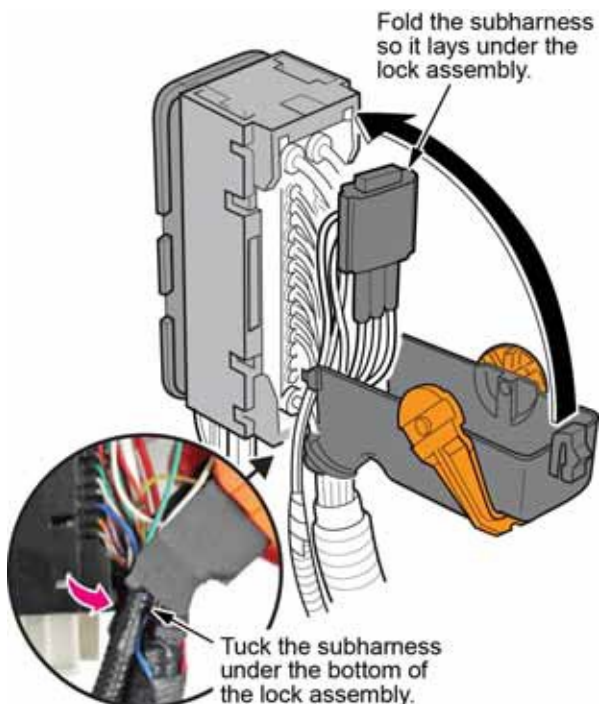

15. Make sure the lance release housing is in the unlocked position, then fully insert the lance release tool into the hole as shown.

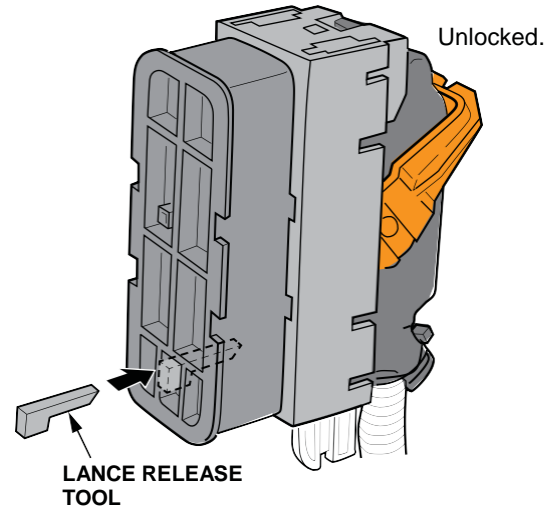

16. Remove the lance release tool, then remove the lance release housing.

NOTE: You may have to slightly squeeze the ends of the connector to remove the lance release housing.

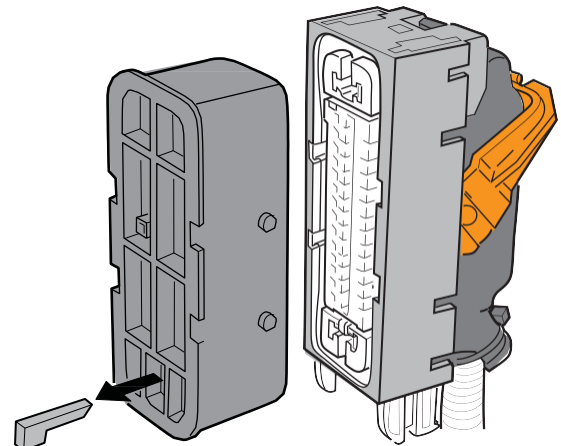

17. Inspect the primary lock to make sure it is in the locked position.

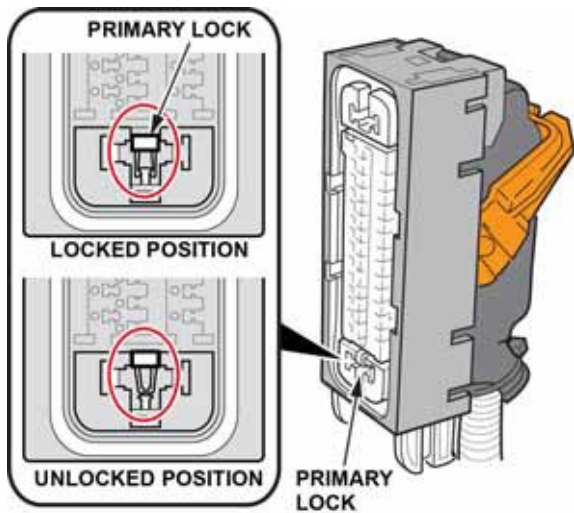

18. Reconnect the 47P connector to the VSA modulator-control unit by making sure it is properly aligned, then moving the lock to the locked position.

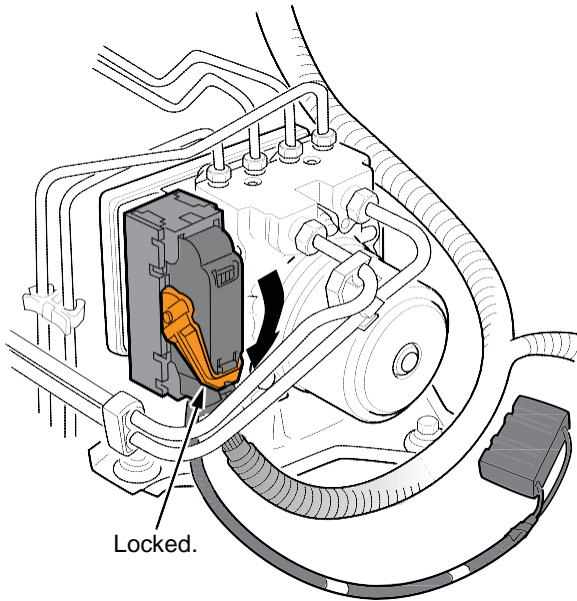

19. Route the subharness as shown. Use the two wire ties provided in the kit to secure the capacitor to the wire harness.

- Wrap wire tie A around the capacitor and the vehicle harness only. Do not wrap it around the VSA subharness.
- Wrap wire tie B around the capacitor, the vehicle harness, and the VSA subharness.

> Wire Ties (2)

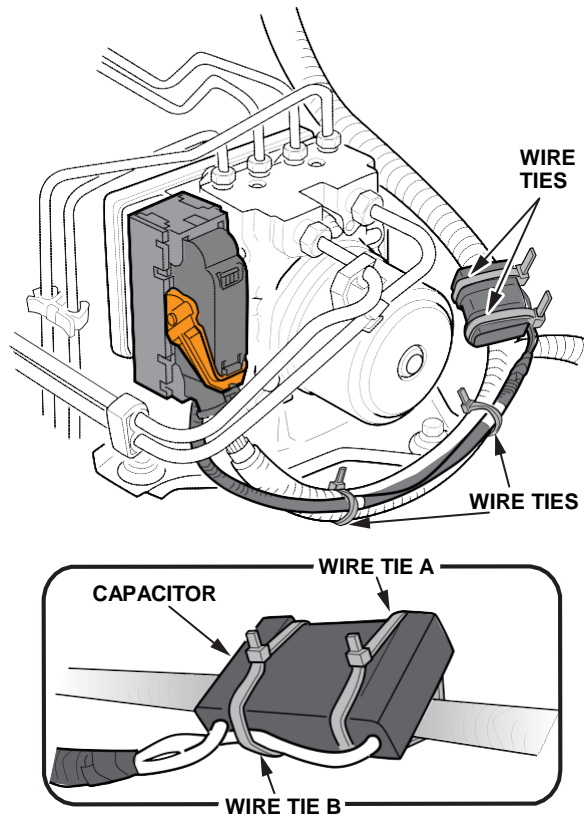

20. Secure the VSA subharness to the vehicle harness in the area of the white tape as shown, then reconnect any disconnected wire harness clips.

> Wire Ties (2)

21. Reinstall all items in the reverse order of removal.

22. Start the engine and make sure the VSA system indicator goes off.

REPAIR PROCEDURE – RL

1. Turn the ignition switch to LOCK (0).
2. Remove the right upper fender trim.

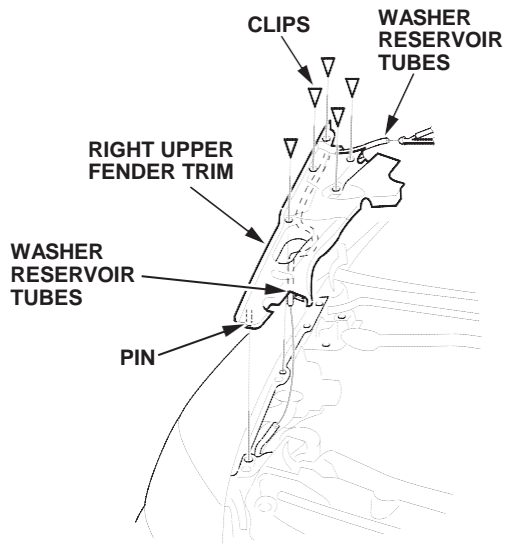

3. Disconnect the windshield washer hose from its holder.

4. Disconnect the VSA modulator-control unit 47P connector.

NOTE:

- Do not force the lock because if you break it, the entire harness must be replaced. Make sure that you press the release tab before trying to move the lock. If needed, wiggle the connector while moving the lock to release the sliding mechanism in the connector.
- Disconnect the harness clips as needed to access the harness.

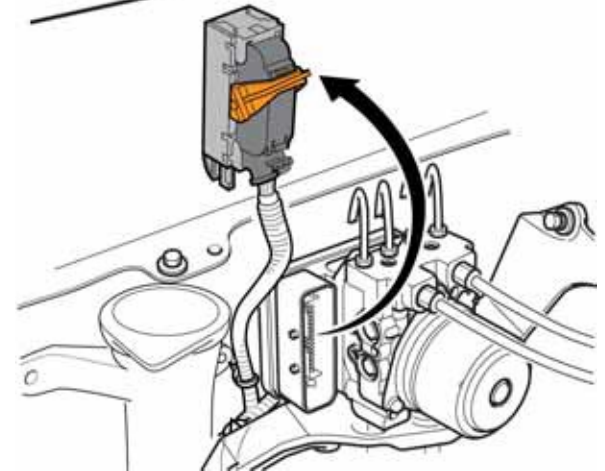
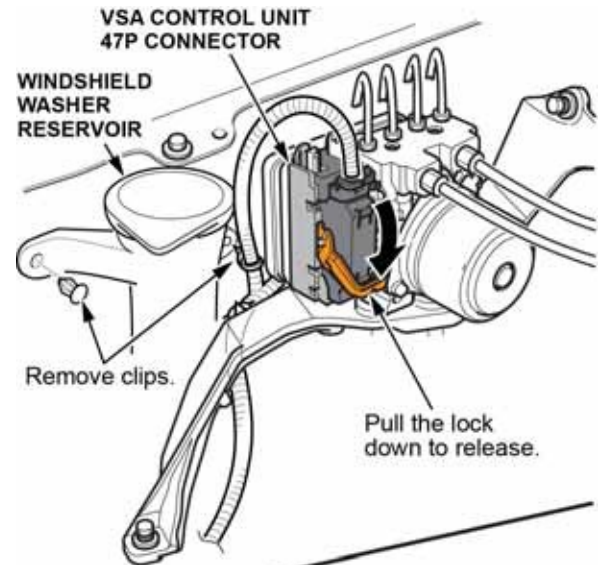

5. Insert the lance release housing into the 47P connector.

LANCE RELEASE HOUSING

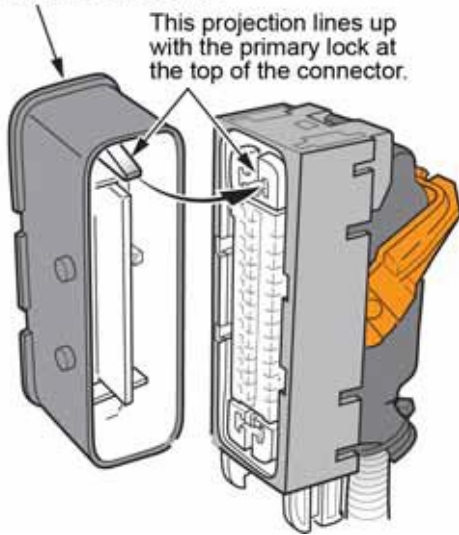

6. Move the lock to the locked position. The lance release housing is fully drawn into the connector and clicks into place.

NOTE:

- Do not apply excessive force.
- If the lock sticks or will not move smoothly, return the lock to its original position, recheck the position of the lance release housing, and try again.

LANCE RELEASE HOUSING

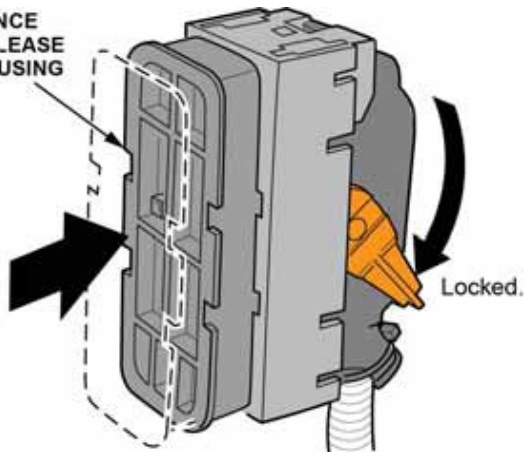

7. Use a small screwdriver to unlock and remove the lock assembly from the 47P connector.

Press to release lock assembly.

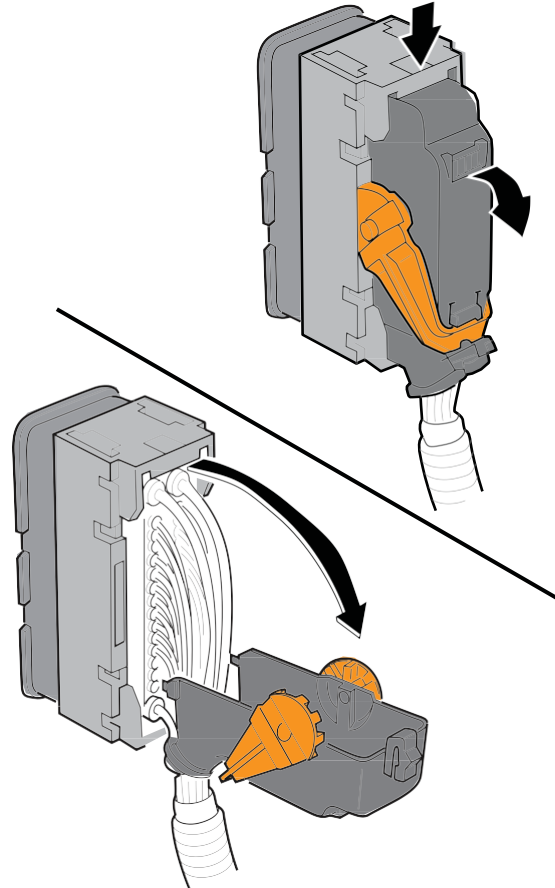

- Remove the No. 35 pink wire terminal from the connector while pushing up on the lance release housing.

NOTE: Take note of the orientation of the notch in the terminal when it comes out because you'll insert the new terminal the same way.

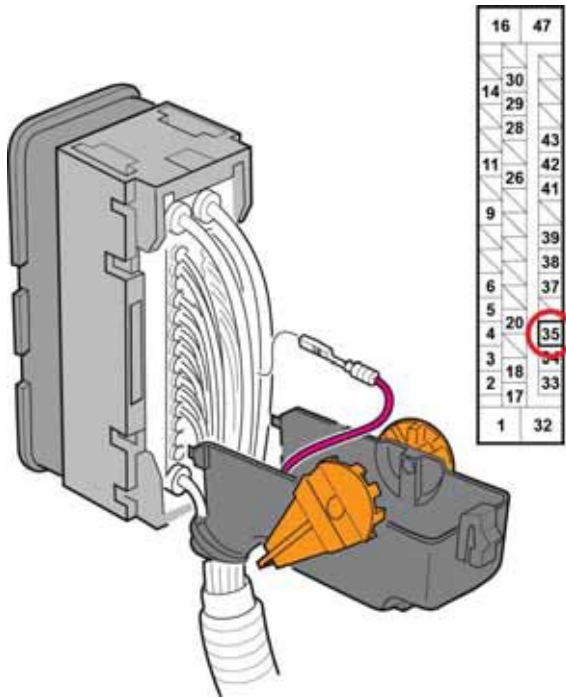

- Insert the cavity plug remover into the hole in the lance release housing as shown, and push out the plug from the No. 22 cavity.

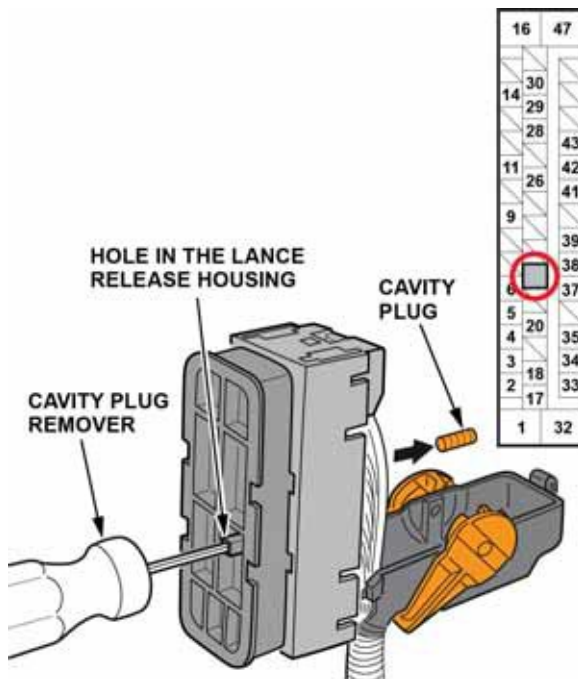

- Tuck the loose terminal and wire into the housing, then install the lock assembly onto the 47P connector as shown.

NOTE:

- Make sure the harness and the wire are not pinched.
- Make sure the lock is properly aligned.

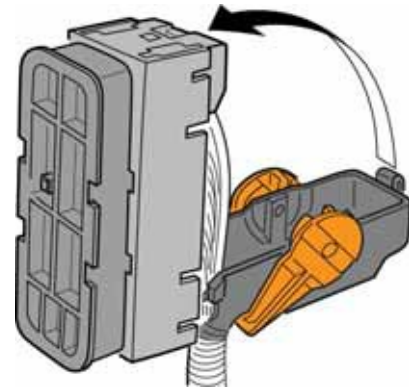

- Press the lock release tab, then move the lock to the unlocked position. The lance release housing also moves into the unlocked position.

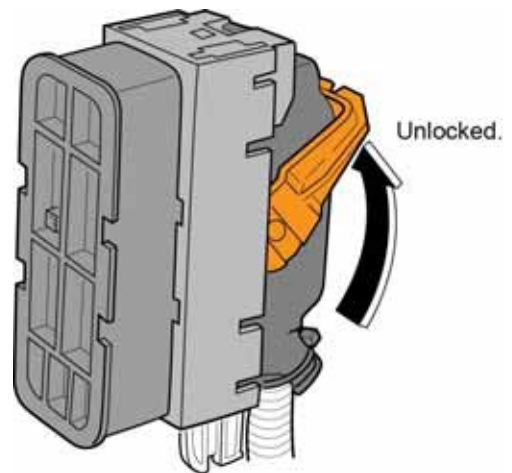

12. Using a small screwdriver, unlock and remove the lock assembly from the 47P connector.

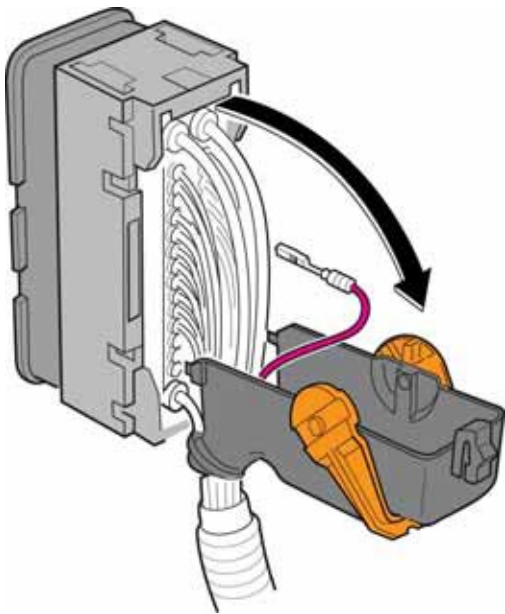

13. Install the VSA subharness.

> Subharness with Capacitor

NOTE:

- Make sure the terminal and connector are properly oriented; the notched part of the terminal should be aligned as shown.

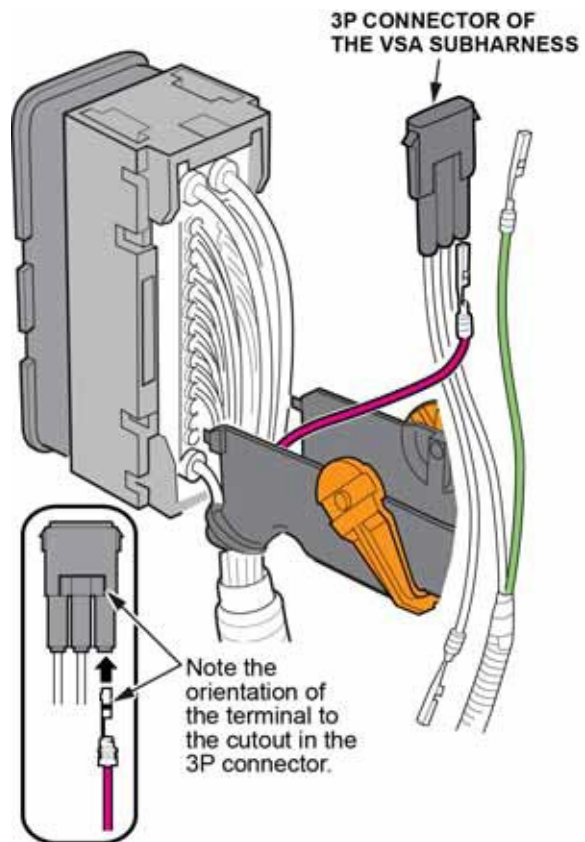

- Do not force the terminal into the connector to avoid damaging the terminals.
- You may hear a click when the terminal is seated in the 3P connector.
- After inserting the terminal into the 3P connector, gently pull on the wire to make sure it is locked into place.

- Insert the pink wire terminal that was removed from cavity No. 35 into the 3P connector of the VSA subharness.
- Insert the VSA harness white wire into the VSA control unit 47P connector terminal No. 35.
- Insert the VSA harness green wire into the VSA control unit 47P connector terminal No. 22.

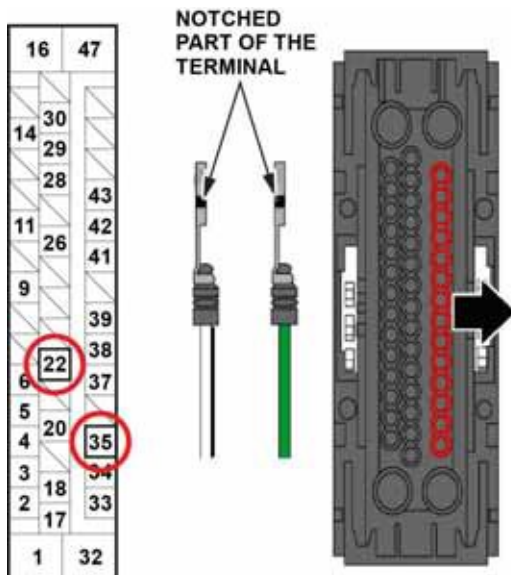
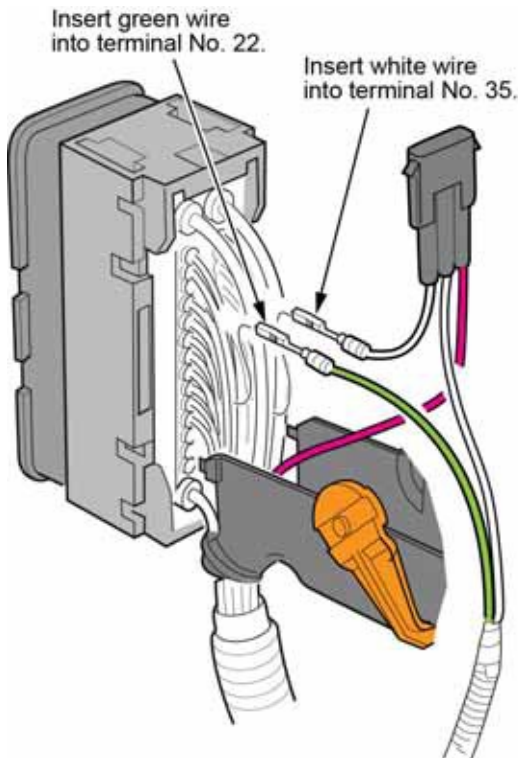

14. Install the short connector to the 3P connector.
 - > 3P Short Connector

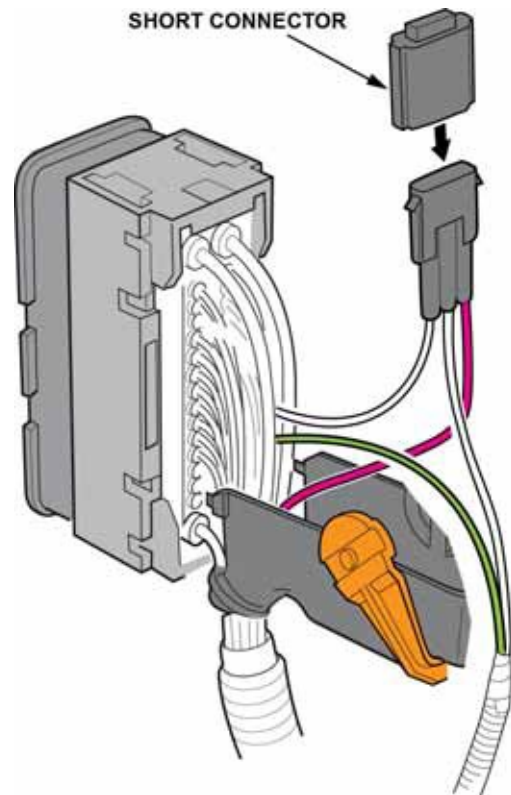

15. Lay out the subharness as shown, then install the lock assembly.

NOTE:

- Make sure the subharness is not pinched.
- Make sure the lock is properly aligned.

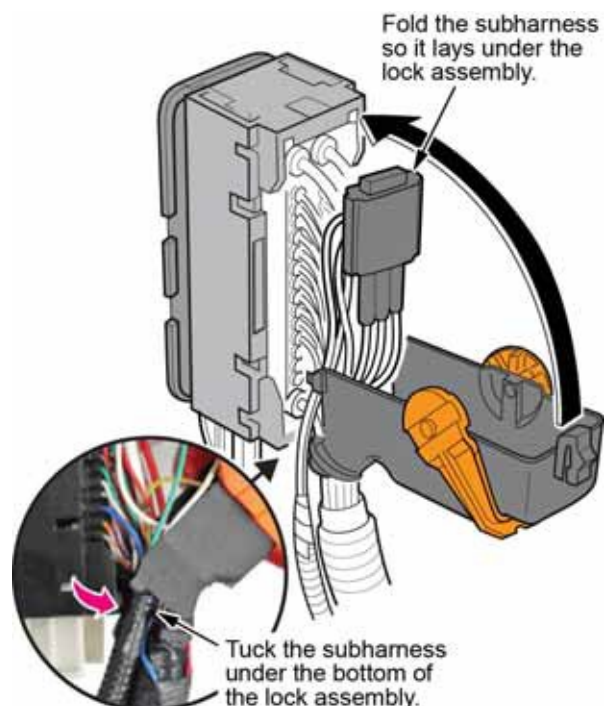

16. Make sure the lance release housing is in the unlocked position, then fully insert the lance release tool into the hole as shown.

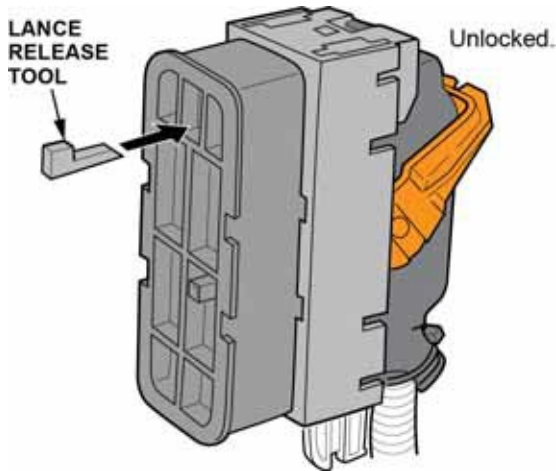

17. Remove the lance release tool, then remove the lance release housing.
NOTE: You may have to slightly squeeze the ends of the connector to remove the lance release housing.

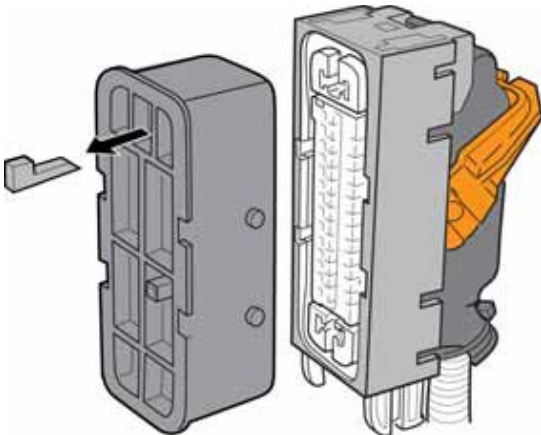

18. Inspect the primary lock to make sure it is in the locked position.

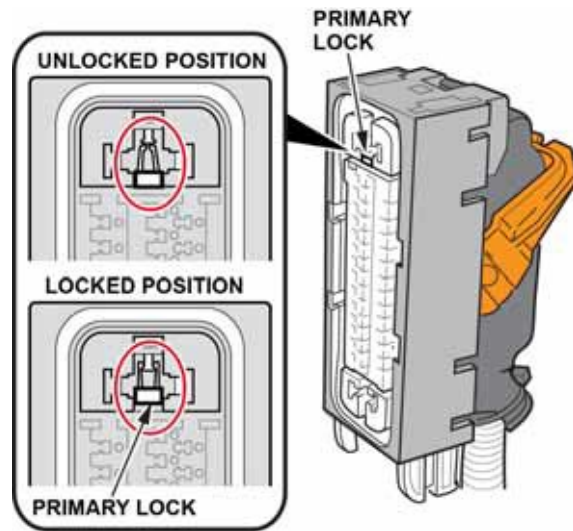

19. Reconnect the 47P connector to the VSA modulator-control unit by making sure it is properly aligned, then moving the lock to the locked position.

20. Route the subharness as shown. Use the two wire ties provided in the kit to secure the capacitor to the wire harness.

- Wrap wire tie A around the capacitor and the vehicle harness only. Do not wrap it around the VSA subharness.
- Wrap wire tie B around the capacitor, the vehicle harness, and the VSA subharness.

> Wire Ties (2)

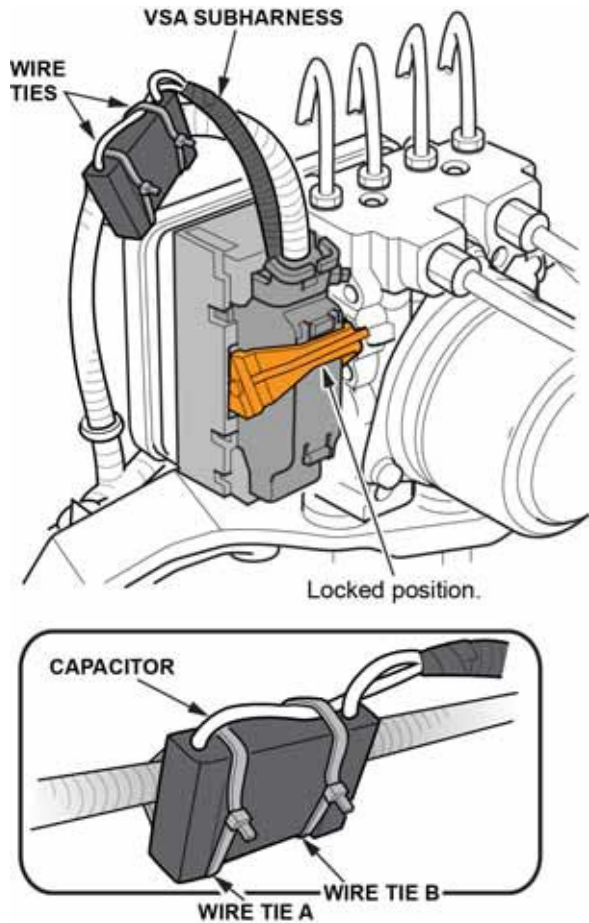

21. Reconnect any disconnected wire harness clips, then reinstall all items in the reverse order of removal.

22. Start the engine and make sure the VSA system indicator goes off.

Example of Client Letter

April 2013

**Safety Recall: 2005–06 MDX and 2005 RL
VSA System Unexpectedly Activates –
NHTSA Recall 13V-092**

Dear Acura Owner:

This notice is sent to you in accordance with the requirements of the National Traffic and Motor Vehicle Safety Act.

What is the reason for this notice?

Acura has decided that a defect which relates to motor vehicle safety exists in certain 2005–06 MDX and 2005 RL vehicles. The Vehicle Stability Assist electronic control unit may have been damaged during the manufacturing process. If the control unit was damaged, the VSA system may apply a small amount of braking force even if the driver has not pressed the brake pedal. If the driver applies the brakes during a malfunction, the VSA system may cause the vehicle to come to an abrupt stop. The unexpected and unnecessary application of brake assist while driving may increase the risk of a crash.

What should you do?

Call any authorized Acura dealer and make an appointment to have your vehicle's VSA system inspected and, if necessary, repaired at no cost to you. The complete replacement process may take approximately 30 minutes; however, your vehicle will need to be at the dealer for a longer period of time. We recommend that you plan to leave your vehicle for half a day to allow the dealer flexibility in scheduling.

Who to contact if you experience problems

If you are not satisfied with the service you receive from your Honda dealer, you may write to:

American Honda Motor Co., Inc.
Acura Client Relations
Mail Stop 500-2N-7E
1919 Torrance Blvd.
Torrance, CA 90501-2746

If you believe that American Honda or the dealer has failed or is unable to remedy the defect in your vehicle, without charge, within a reasonable period of time (60 days from the date you first contact the dealer for a repair appointment), you may submit a complaint to:

Administrator
National Highway Traffic Safety Administration
1200 New Jersey Avenue, SE
Washington, DC 20590

You can also call the toll-free Safety Hotline at 1-888-327-4236 (TTY 1-800-424-9153), or go to www.safercar.gov.

What to do if you feel this notice is in error:

Registration records indicate that you are the current owner or lessee of a 2005–06 MDX and 2005 RL involved in this campaign. If this is not the case, or the name/address information is not correct, please complete and sign the Information Change Card and return it in the enclosed postage-paid envelope. We will then update our records.

Lessor Information

Federal law requires that any vehicle lessor receiving this recall notice must forward a copy of this notice to the lessee within 10 days.

If you have questions

If you have any questions about this notice, or need assistance with locating an Acura dealer, please call Acura Client Relations at 1-800-382-2238, and select option 4. U.S. clients can also locate a dealer online at Acura.com. Clients in U.S. territories, please contact your local dealer/distributor.

We apologize for any inconvenience this campaign may cause you.

Sincerely,

**American Honda Motor Co., Inc.
Acura Automobile Division**