



TO: Winnebago Industries, Inc. Dealers

SUBJECT: Campaign #128 – Range Enclosure

The National Traffic and Motor Vehicle Safety Act, as amended, provides that each vehicle which is subject to a recall campaign of this type must be adequately repaired within a reasonable time after the owner has tendered it for repair. A failure to adequately repair within 60 days after tender of a vehicle is prima facie evidence of failure to repair within a reasonable time.

If the condition is not adequately repaired within a reasonable time, the owners may be entitled to an identical or reasonably equivalent vehicle at no charge or to a refund of the purchase price less a reasonable allowance for depreciation.

To avoid having to provide these burdensome solutions, every effort must be made to promptly schedule an appointment with each owner and to repair their vehicle as soon as possible. As you will see in reading the enclosed copy of the letter which is being sent to owners, the owners are being instructed to contact Winnebago Industries, Inc. if you do not remedy the condition within five days of the mutually agreed upon service date. If the condition is not remedied within a reasonable time, they are instructed on how to contact the National Highway Traffic Safety Administration.

REASON FOR THIS RECALL

Winnebago Industries, Inc. has decided that a defect which relates to motor vehicle safety exists on certain 2012, 2013, and 2014 Model Year Winnebago® (Models: Minnie Winnie®, Chalet®, Aspect®, Sightseer®, Adventurer®, and Journey®). Certain 2012, 2013, and 2014 Model Year Itasca® (Models: Spirit®, Cambria®, Sunova®, Suncruiser®, and Meridian®).

These motorhomes were manufactured January 10, 2012 through April 5, 2013. These vehicles may have a missing range enclosure that isolates the range from air movement that could put out the flame. Either positive or negative airflow can disrupt the flame and may extinguish the flame. If the range flame goes out and the propane gas continues to flow, it has the potential to ignite resulting in personal injury and/or vehicle and property damage.

OWNER NOTIFICATION

Owners will be notified of this campaign on their vehicles by Winnebago Industries, Inc. For all units in your inventory, the notification will be mailed to you. **DO NOT DELIVER TO A CUSTOMER ANY SUBJECT UNIT UNTIL CORRECTIVE ACTION HAS BEEN TAKEN.** Enclosed is a list of vehicles shipped to you.

DEALER CAMPAIGN RESPONSIBILITY

Dealers are to service all vehicles subject to this campaign at no charge to owners regardless of mileage, age of vehicle, or ownership from this time forward. Whenever a vehicle subject to this campaign is taken into new or used vehicle inventory or it is in your dealership for service in the future, you should take the steps necessary to be sure the campaign correction has been made before reselling or releasing the vehicle. Owners of vehicles recently sold from your new vehicle inventory are to be contacted by the dealer and arrangements made to make the required correction according to instructions contained in this campaign.

INSTRUCTION TO PERFORM CAMPAIGN #128

Affected Models:

- Certain 2012, 2013, and 2014 Model Year Winnebago (Models: Minnie Winnie, Chalet, Aspect, Sightseer, Adventurer, and Journey).
- Certain 2012, 2013, and 2014 Model Year Itasca (Models: Spirit, Cambria, Sunova, Suncruiser, and Meridian).

Repair Procedure:

Refer to instruction sheet for installation of range enclosure.

Parts Information:

To minimize any inconvenience to your customers, we strongly encourage you to promptly order part kits for the vehicles on the attached list. This will ensure you have adequate inventory for your customers. Order the following Part Kit from Winnebago Industries® using the WinPortal system. You will be placing the order as a recall order. You will need the recall dealer number and the Winnebago Industries serial number of the affected vehicle to place the order.

- Part Number RC7698-13-728 is for Atwood® range top installation.
- Part Number RC7699-13-728 is for Atwood range with oven installation.
- Part Number RC7600-13-728 is for Suburban® range top installation.

Dealer Number: 7698		
Qty.	Part Description	Part Number
1	Instruction Sheet	RC7698-13-728
1	Range Enclosure	

Dealer Number: 7600		
Qty.	Part Description	Part Number
1	Instruction Sheet	RC7600-13-728
1	Range Enclosure	

Dealer Number: 7699		
Qty.	Part Description	Part Number
1	Instruction Sheet	RC7699-13-728
1	Range Enclosure	

REIMBURSEMENT

When the service has been completed, submit the labor amount and labor operation number listed below. Your repair order must be properly signed by both the dealer and the owner.

	OPERATION NUMBER <u>Dealer No.: 7698</u>	OPERATION NUMBER <u>Dealer No.: 7699</u>	OPERATION NUMBER <u>Dealer No.: 7600</u>
INSTALLATION OF RANGE ENCLOSURE	24280101	24280201	24280301
TIME ALLOWANCE	0.7 hr.	0.7 hr.	0.7 hr.

Thank you for your cooperation.

Winnebago Industries, Inc.
Forest City, Iowa 50436

Enclosures



**RE: BODY SERIAL
CHASSIS SERIAL**

Dear Owner:

This notice is being sent to you in accordance with the requirements of the National Traffic and Motor Vehicle Safety Act. Our records indicate that you have purchased a vehicle with the serial number which appears above.

REASON FOR THIS RECALL

Winnebago Industries, Inc. has decided that a defect which relates to motor vehicle safety exists on certain 2012, 2013, and 2014 Model Year Winnebago® (Models: Minnie Winnie®, Chalet®, Aspect®, Sightseer®, Adventurer®, and Journey®). Certain 2012, 2013, and 2014 Model Year Itasca® (Models: Spirit®, Cambria®, Sunova®, Suncruiser®, and Meridian®).

These motorhomes were manufactured January 10, 2012 through April 5, 2013. These vehicles may have a missing range enclosure that isolates the range from air movement that could put out the flame. Either positive or negative airflow can disrupt the flame and may extinguish the flame. If the range flame goes out and the propane gas continues to flow, it has the potential to ignite resulting in personal injury and/or vehicle and property damage.

WHAT WE WILL DO

Winnebago Industries, Inc. dealers will correct this situation by installing a range enclosure that isolates the range from air movement under the galley cabinet at no charge to you.

WHAT YOU SHOULD DO

Please contact your Winnebago Industries, Inc. dealer immediately to arrange for an appointment. Please allow sufficient time for your dealer to obtain the kit for this recall. The labor time necessary to perform this correction will be approximately one hour. Please allow additional time for the dealer to process your vehicle.

Winnebago Industries, Inc. dealers are best equipped to obtain parts and provide service to ensure your vehicle is corrected as promptly as possible. HOWEVER, if you take your vehicle to the dealer on the agreed date and he does not service this condition on that date or within five days, we recommend you contact Winnebago Industries, Inc., Attn.: Owner Relations Representative (641-585-6939). If you are still unable to obtain such service without charge to you and within a reasonable time, you may contact The Administrator, National Highway Traffic Safety Administration, 1200 New Jersey Avenue S.E., Washington, DC 20590 or call the toll-free Vehicle Safety Hotline at 1-888-327-4236 (TTY: 1-800-424-9153) or go to <http://www.safercar.gov>.

IF YOU HAVE PREVIOUSLY PAID FOR THIS REPAIR

If you have paid to remedy this issue, you may be eligible for a refund. To obtain information on a refund, contact Winnebago Industries Owner Relations by e-mail at or@winnebagoind.com; write us at Owner Relations Department, P.O. Box 152, Forest City, Iowa 50436; or by telephone at 1-641-585-6939 or 1-800-537-1885.

Body Serial/Chassis Serial
Page Two

IF YOU HAVE CHANGED ADDRESS OR SOLD THE VEHICLE

If you have changed address or sold or traded your vehicle, please let us know by contacting Winnebago Owner Relations by e-mail at or@winnebagoind.com; in writing at Owner Relations Department, P.O. Box 152, Forest City, Iowa 50436; or by telephone at 1-641-585-6939 or 1-800-537-1885.

Presentation of this letter to the service center will assist in making the necessary correction to your vehicle in the shortest possible time.

Federal law requires that any vehicle lessor receiving this recall notice must forward a copy of this notice to the lessee within ten days.

We are sorry to cause you this inconvenience; however, we have taken this action in the interest of your safety and continued satisfaction with our products. This letter does not constitute an acknowledgment of legal liability.

Winnebago Industries, Inc.
Forest City, Iowa 50436

Enclosure



INSTRUCTIONS TO PERFORM CAMPAIGN 128

Atwood Models Affected:

- Certain 2012 and 2013 model year Winnebago® (Models: Aspect®, Sightseer®, Adventurer®, and Journey®)
- Certain 2012 and 2013 model year Itasca® (Models: Cambria®, Sunova®, Suncruiser®, and Meridian®)
- 2013 model year Winnebago (Model: 200 Chalet®)

These motor homes were manufactured January 10, 2012 through March 1, 2013.

Suburban Models Affected:

- Certain 2014 model year Winnebago® (Minnie Winnie®)
- Certain 2014 model year Itasca® (Spirit®)

These motor homes were manufactured September 14, 2012 through April 5, 2013.

Tools Required:

- Screw Gun (w/#2 Phillips Tip)
- 5/8" and 13/16" Open-End Wrench
- Stapler (Office Stapler)
- LP Leak Detector Solution

Kit Includes:

- Range Enclosure
- Instructions

Procedure:

Install a range enclosure that isolates the range from the positive or negative air flow within the cabinet.

Atwood Range



Atwood Range with Oven



Suburban Range



Atwood Range Enclosure
RC7698-13-728

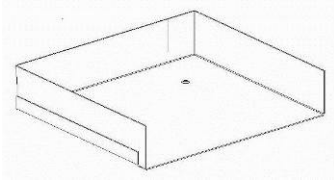

Atwood Range with
Oven Enclosure
RC7699-13-728

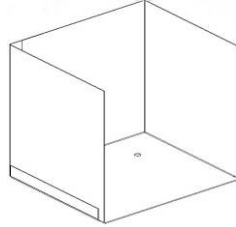

Suburban Range
Enclosure
RC7600-13-728

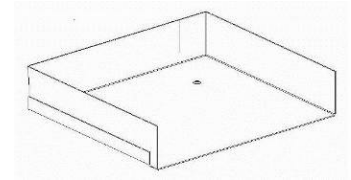

1. Shut off the LP gas on outside of coach.



2. (**Atwood**) Remove (2) grates, (3) burners and disconnect igniters, then remove range top.

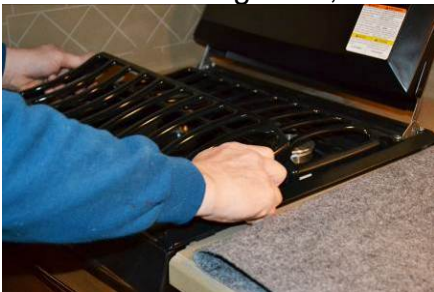

2. (**Suburban**) Remove range top.



3. Remove clamp from LP gas line.



4. Remove four screws to loosen range for removal (two on each side).



5. Using a 5/8" and 13/16" open-end wrench, loosen and disconnect LP gas line.



6. Remove range.



7. Using the perforated lines, fold the stove enclosure into rectangular position and staple to hold shape, making sure the outer lip is stapled to the outside of the stove enclosure.



**Atwood &
Suburban Range
Enclosure**

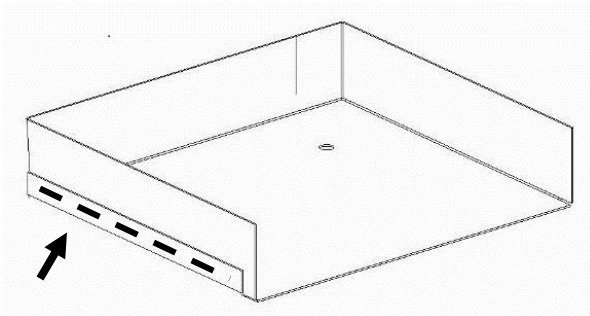

Staple along this
edge.

**Atwood Range
with Oven
Enclosure**

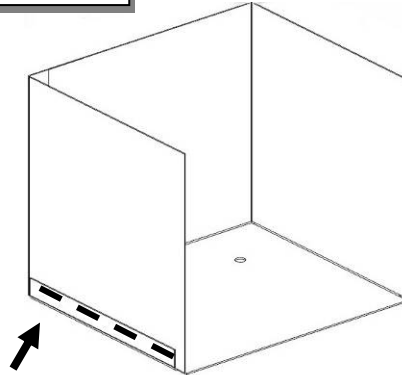

Staple along this
edge.

8. Insert stove enclosure making sure to bring the LP gas line through the stove enclosure hole. Attach to all sides of the countertop/cabinet assembly using a stapler to hold the stove enclosure in place.



**NOTE: Be sure
to staple
perimeter of
enclosure to
cabinet face.**

9. Reinstall range and four screws (two on each side) to secure range into place.



10. Reinstall clamp for LP gas line.



11. Reconnect LP gas Line.



12. Open the LP gas valve on the outside of coach.



13. Perform an LP leak test by spraying LP leak detector solution on the LP gas line fitting, if bubbles/leak appears correct and retest.



- (Atwood)** If the LP leak test passed, continue with the following steps (a-c)
- a. Place fabric washers on each burner post.

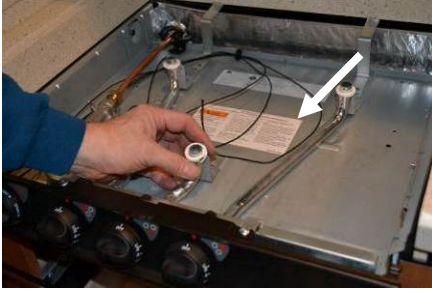

- b. Reinstall range top and insert the igniter leads through the burner holes.



- c. Reconnect (3) igniters, (3) burners and Reinstall (2) grates.



- (Suburban)** If the LP leak test passed, reinstall the range top.



14. Operational Test:

- a. Test the three burners to verify proper ignition and operation.
- b. Turn off all three burners at the range top.
- c. Close the LP gas valve on the outside of coach.