

**Important Safety Recall Notice**  
**Subaru Recall Campaign WQF42-2**  
**NHTSA Recall No. 13V-061**  
**April 2013**



**Subaru of America, Inc**  
Subaru Plaza  
PO Box 6000  
Cherry Hill, NJ 08034-6000  
800-782-2783  
www.subaru.com

**Dear Subaru Owner:**

This notice is sent to you in accordance with the requirements of the National Traffic and Motor Vehicle Safety Act. SUBARU OF AMERICA, INC. has decided that a defect, which relates to motor vehicle safety, exists in some 2010 through 2013 model year Subaru vehicles equipped with optional Genuine Subaru Remote Engine Starters. **If your vehicle is not equipped with an optional remote engine starter, this notice does not apply to you.**

**DESCRIPTION OF THE SAFETY DEFECT**

Subaru has determined that certain vehicles equipped with an optional Remote Engine Starter (RES) include remote transmitter fobs that could malfunction and cause the vehicle's engine to unexpectedly start.

Remote transmitter fobs, usually attached to a vehicle key ring/holder, allow the vehicle operator to remotely start the vehicle's engine from a location of up to 400 feet away. If an RES transmitter fob is dropped, movement of the internal battery retaining clip may occur and cause damage to a component on the PC board. Under this condition, the fob may transmit an engine start (or stop) request at any time without the user pressing the button. If the vehicle is in range and receives the request, the engine may start and run for up to 15 minutes (or until a stop request is received). The engine may continue to start and stop until the fob battery is depleted, or until the vehicle runs out of fuel.

**DESCRIPTION OF THE SAFETY HAZARD**

If a remote transmitter fob were to malfunction and cause the engine to start when the vehicle is parked in an enclosed area, such as a garage, there is a risk of carbon monoxide build-up which may cause headaches, dizziness or, in extreme cases, unconsciousness and/or asphyxiation.

The defect does not pose a risk while driving because the RES system is completely deactivated after the vehicle is started with the key. The keyless entry feature on your vehicle's ignition key (used to lock and unlock the doors) is not affected.

**REPAIRS**

To correct this condition, Subaru will replace the original RES transmitter fobs and reprogram the new ones at no cost to you.

**WHAT YOU SHOULD DO**

If your vehicle is equipped with optional RES or if you are unsure whether your vehicle is equipped with optional RES, you should immediately contact your Subaru Dealer for an appointment to have your vehicle inspected and if necessary, this repair performed at no cost to you. If you are certain that your vehicle is not equipped with RES, no further action is necessary.

There are several important precautions you should take until this repair has been performed:

- The batteries should be removed from the RES transmitter fobs rendering them completely inoperable. (See battery removal instructions at the end of this letter.)
- As a precautionary measure, it is highly recommended that you not park your vehicle in an enclosed garage unless the transmitter fob batteries have been removed or the fobs replaced.

**HOW LONG WILL THE REPAIR TAKE?**

The actual time to replace and reprogram the replacement RES transmitter fobs is approximately 15 minutes. However, it may be necessary to leave your vehicle for a longer period of time on the day of your scheduled appointment to allow your dealer flexibility in scheduling. Please present this letter to your Subaru Dealer at the time this repair procedure is performed. **Please be sure to bring all RES transmitter fobs with you at the time of your appointment. They are needed to complete this repair.**

**IF YOU HAVE PREVIOUSLY PAID FOR A REPAIR**

If you have already paid for repairs associated with this condition, you may be eligible for reimbursement. Reimbursement consideration will be based on the amount an authorized Subaru dealer in your area would charge for performing those repairs.

*continued...*

Please send the original service repair order, which has the name of the repair facility, date of repair, mileage at the time of repair, complete vehicle identification number (17 digits), and your name, with correct mailing address and telephone number to the address listed below.

**Subaru of America, Inc.**  
**Customer Dealer Services Department**  
**Attention: WQF-42 Recall**  
**P.O. Box 6000**  
**Cherry Hill, NJ 08034-6000**

Please send original receipts only and retain a photocopy for your records. Please be assured that we will attempt to process your reimbursement request as quickly as possible, but it may take up to 60 days for this process to be completed.

**CHANGED YOUR ADDRESS OR SOLD YOUR SUBARU?**

If you have moved or sold your vehicle, please complete the enclosed postage prepaid postcard and mail it to us. Or, if you prefer to update this information online, please go to [www.subaru.com](http://www.subaru.com), select Contact Us then select Update Address from the drop down menu.

**IF YOU NEED FURTHER ASSISTANCE:**

To locate the nearest Subaru Dealer you can access our website at [www.subaru.com](http://www.subaru.com) and select “Find a Dealer”. For additional information and for the most Frequently Asked Questions, please go to:

- <http://www.wqf42.service-campaign.com>

If you need additional assistance, please contact us directly:

- E-mail: Go to [www.subaru.com](http://www.subaru.com) and select “Contact Us”.
- Telephone: 1-800-SUBARU3 (1-800-782-2783)  
Monday through Thursday between 7:30 a.m. and 8:00 p.m. ET.  
Friday between 10:30 a.m. and 5:00 p.m. ET  
Saturday between 9:00 a.m. and 3:30 p.m. ET
- U.S. Postal mail: Write us at Subaru of America, Inc.  
Attn: CDS Department, P.O. Box 6000, Cherry Hill, NJ 08034-6000.

Please contact us immediately if the dealer fails or is unable to make the necessary repairs free of charge.

You may also contact the Administrator, National Highway Traffic Safety Administration, 1200 New Jersey Ave. SE, West Building, Washington, DC 20590 or call the toll free Auto Safety Hotline at 1-888-327-4236 (TTY: 1-800-424-9153) or go to <http://www.safercar.gov> if you believe the dealer has failed or is unable to remedy your vehicle without charge within a reasonable amount of time.

Your continued satisfaction with your Subaru is important to us. Please understand that we have taken this action in the interest of your safety and your vehicle’s proper operation. We sincerely apologize for any inconvenience this matter may cause and urge you to schedule an appointment as soon as possible to have this repair performed.

Sincerely,  
Subaru of America, Inc.

**Notice to Lessors:** Under Federal law the lessor of a vehicle who receives this letter must provide a copy of it to the vehicle lessee(s) within 10 business days from receipt. The lessor must also keep a record of the lessee(s) to whom this letter is sent, the date sent, and the applicable vehicle identification number (VIN). (For the purposes of this section, a lessor means a person or entity that in the last twelve months prior to the date of this notification has been the owner, as referenced on the vehicle’s title, of any five or more leased vehicles. A leased vehicle is a vehicle leased to another person for a term of at least four months.)

*A subsidiary of Fuji Heavy Industries Ltd.*

**Instructions for RES Transmitter Fob Battery Removal**

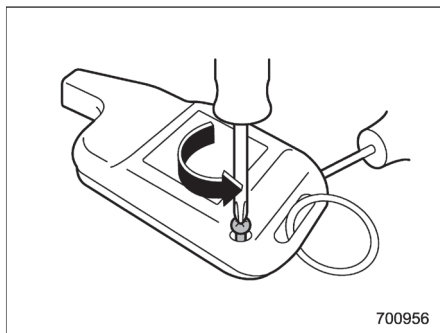

1. Remove the small Phillips type screw located on the back side lower left corner of the transmitter.
2. Carefully pry the transmitter halves apart using a small flat-head screwdriver

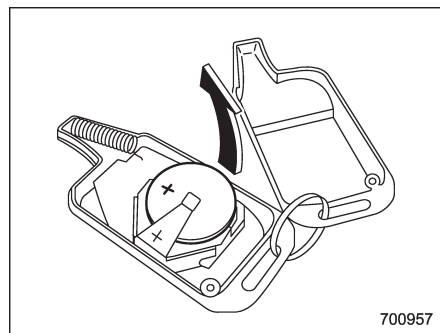

3. Remove the circuit board from the bottom half of the case and remove the batteries.