



America's Best Engineered
Truck Accessories

January 21, 2014

VIA FIRST CLASS MAIL

John B. Sample
1075 Hillside Rd
Dallas, TX 75062

NHTSA 13E-066
Owner Reference S2NZ30

IMPORTANT SAFETY RECALL

Dear Vehicle Owner:

This notice is sent to you in accordance with the requirements of the National Traffic and Motor Vehicle Safety Act.

Extang Corporation ("Extang") has decided that a defect which relates to motor vehicle safety exists in vehicles equipped with Extang's *Encore* tonneau covers. Accordingly, pursuant to 49 CFR 573, Extang has given notice to the National Highway Traffic Safety Administration of its intent to conduct a safety recall of all Extang *Encore* tonneau covers built from September 2011 through September 2013. **Available records indicate that you may have purchased an *Encore* tonneau cover for use on a pick-up truck.**

REASON FOR THIS RECALL

The *Encore* tonneau is a hard panel, tri-fold pick-up truck bed tonneau cover that has been sold in the U.S. as an aftermarket accessory for pick-up trucks. The rear latch secures the cover at the tailgate and the front latch and lock secures the front panel at the cab. Both panels must be closed and secured during vehicle operation. The front panel may become unsecured while driving, allowing wind to lift and separate the cover from the truck bed. If the cover separates from the truck bed, it may become a road hazard, increasing the risk of a crash. Information on how to identify an *Encore* tonneau cover is contained at the end of this letter.

WHAT WE WILL DO

If you have an *Encore* tonneau cover on your vehicle, Extang will install, free of charge, two tether straps that are intended to secure the tonneau cover to the frame assembly. The repair will only take about 15 to 30 minutes to complete, though additional time may be necessary depending on service schedules.

Extang will reimburse owners who have incurred the cost of repairing or replacing an *Encore* tonneau cover that separated from its mounting and was damaged as a result of the front panel being unsecured. You will need to send the original receipt and/or other adequate proof of payment for confirmation of the reimbursement expense.

EXTANG RECALL SUPPORT

105 Decker Court, Suite 300
Irving, TX 75062 USA
TEL: 866-432-1329
FAX: 866-397-2712

www.extang.com



America's Best Engineered
Truck Accessories

Extang has engaged the services of Impartial Services Group (“ISG”), a third-party service provider that will assist Extang with the administration of this recall. ISG will assist you in arranging for the repair of your *Encore* tonneau cover at no cost to you.

WHAT YOU SHOULD DO

Please call our representatives toll free at 866-432-1329 or visit www.TruckbedCoverRecall.com to arrange for the free repair of your *Encore* tonneau cover or are seeking reimbursement for an *Encore* tonneau cover repair or replacement.

If for some reason you are unable to have the service correction made within a reasonable time or without charge, you may submit a written complaint to: National Highway Traffic Safety Administration, 1200 New Jersey Avenue SE, West Building, Washington, DC 20590. You may call the toll-free Vehicle Safety Hotline at: 1-888-327-4236 (TTY: 1-800-424-9153); or go to <http://www.safercar.gov>.

We regret any inconvenience this action may cause you and we look forward to your help in executing this recall campaign. As we are sure you will appreciate, the safety and quality of our products are of the utmost importance to us.

Thank you for your attention and cooperation in this matter.

Sincerely,

Steve Kelley
Vice President

cc: National Highway Traffic
Safety Administration

How to Identify an Encore Tonneau Cover

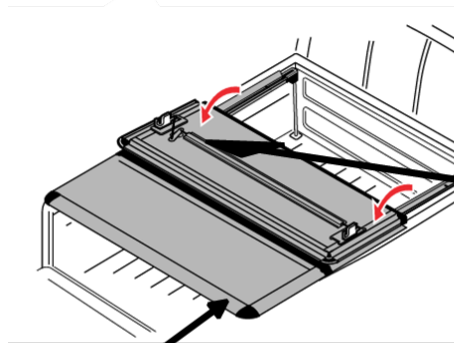

This part number label will appear on the inside of the front panel. The *Encore* tonneau covers all start with “62xxx” in the part number sequence.

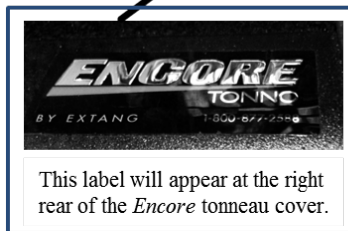

This label will appear at the right rear of the *Encore* tonneau cover.



Shipping box markings for the *Encore* tonneau cover (includes part number “62xxx”).

EXTANG RECALL SUPPORT
105 Decker Court, Suite 300
Irving, TX 75062 USA
TEL: 866-432-1329
FAX: 866-397-2712



Truck Bed Cover Recall Center
105 Decker Court, Suite 300
Irving, TX 75062

Pre-Sorted
First Class Mail
US Postage PAID
Portland OR
Permit No 3785

IMPORTANT SAFETY RECALL INFORMATION



**U.S. Department of
Transportation**

**Issued in Accordance
With Federal Law**

