

TMS-NTC-13178  
July 23, 2013

Recall Management Division  
National Highway Traffic Safety Administration  
1200 New Jersey Avenue, SE  
Washington, DC 20590

Re: Toyota Safety Recall 13V-235 Dealer Notification - Remedy

To whom it may concern,

Please find attached the Dealer Notification - Remedy Letter for Toyota Safety Recall 13V-235 on the following Toyota and Lexus vehicles:

- Certain 2010 Model Year HS250h Vehicles
- Certain 2010 Model Year Prius Vehicles

We will send a DVD with the video links mentioned in the Remedy Instructions under separate cover due to the size of the video file.

If you have any questions regarding this matter, please contact me at (310) 468-5316.

Sincerely,

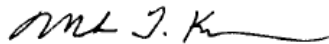

Quality Compliance Assistant Manager

Attachments:

- Lexus 13V-235 (DLD) Dealer Notification (Remedy)
- Toyota 13V-235 (D0H) Dealer Notification (Remedy)



July 24, 2013

**Subject:** Safety Recall DLD - **Remedy Available**  
 Certain 2010 Model Year HS 250h Vehicles  
 Brake Booster Pump Assembly (Accumulator)

Dear Dealer Principal:

As previously announced on June 5, 2013, Lexus filed a Defect Information Report (DIR) with the National Highway Traffic Safety Administration (NHTSA) informing the agency of our intent to conduct a voluntary Safety Recall on certain 2010 Model Year HS 250h vehicles.

*Lexus has completed remedy preparations and will now begin mailing the remedy owner letter.*

#### Condition

The subject vehicles are equipped with a brake booster pump assembly which can develop a crack inside the accumulator housing. If this occurs, nitrogen gas could leak into the brake fluid and gradually cause a loss of power assist. Under certain circumstances, this could affect the stopping distance and increase the risk of a crash.

#### Remedy

Lexus dealers are requested to perform an inspection and, if necessary, replace the brake booster pump assembly at **NO CHARGE** to the vehicle owner. For additional information on repair procedures please refer to TIS.

#### Owner Notification

Lexus has completed remedy preparations and will begin to notify owners of covered vehicles in late July, 2013. A sample of the owner notification letter has been included for your reference.

*Lexus tries very hard to obtain current customer name and address information when mailing owner letters. In the event your dealership receives notices for vehicles that were sold prior to the Safety Recall announcement, it is the dealership's responsibility to forward the owner letters to the customers who purchased the vehicles.*

Please note that only owners of the covered vehicles will be notified. If your dealership is contacted by an owner who has not yet received the notification, please **verify coverage by confirming through Dealer Daily/TIS**. Dealers should perform the procedure as outlined in the Technical Instructions located on TIS.

#### Identification of Covered Vehicles

There are approximately 5,100 Lexus HS 250h (Certain 2010 Model Year) vehicles covered by this Safety Recall in the US.

Model	Model Year	VDS	Start	Finish
HS 250h	Certain 2010	BB1BA	2000186	2009302

#### Pre-Owned Vehicles in Dealer Inventory

Lexus requests that dealers verify whether vehicles in their pre-owned dealer inventory are covered by this Safety Recall. If a vehicle is covered, the dealer should perform the Safety Recall prior to customer delivery.

## Parts Ordering Process

Orders can be placed through each dealer's facing PDC. The kit has been placed on Dealer Ordering Solution (DOS) and will be systematically released daily based on the established order criteria. Each dealer's facing PDC will send an e-mail with dealer specific order criteria. Parts and service managers should work together to schedule appointments based on parts availability within the DOS limits. A sample of the Parts Allocation Report is attached below for your reference.

Part Number	Part Description	Quantity/Vehicle
04002-20247	Pump Assembly, Brake Booster with Accumulator	1

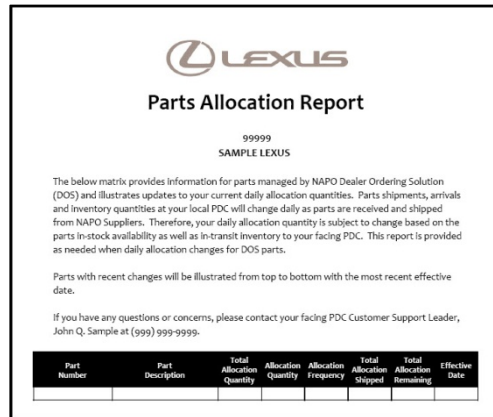

### IMPORTANT PARTS ORDERING UPDATE

*All Safety Recall, Service Campaign (SSC/LSC) and Customer Support Program (CSP) parts are eligible for the Monthly Parts Return Program. Please refer to Service and Parts Operations Communication 2011-20 for campaign parts that are currently returnable under the Monthly Parts Return Program and additional details.*

## Technician Training Requirements

The repair quality of covered vehicles is extremely important to Lexus. All dealership associates involved in the recall process are required to successfully complete E-Learning course LSC13A. It is the dealership's responsibility to select technicians with the proper certification level or greater to perform this Safety Recall repair. Carefully review your resources, the technician skill level, and ability before assigning technicians to this repair. It is important to consider technician days off and vacation schedules to ensure there are properly trained technicians available to perform this repair at all times

## Remedy Procedures

Please refer to TIS for Technical Instructions on inspection and repair.

Dealers are requested to conduct all applicable, non-completed Safety Recall and Service Campaigns on the vehicle during the service appointment.

## Parts Ordering Process (Manual Allocation Control)

Only vehicles that experience the actual condition will require the following part. To ensure parts availability the parts have been placed on Manual Allocation Control (MAC). If your dealership requires this part, please send an e-mail to [Quality\\_Compliance@Toyota.com](mailto:Quality_Compliance@Toyota.com) with the following information:

- Subject Line: DLD MAC Release Request (Dealer Code)
- Dealer Code
- VIN

- Part Number and Quantity Ordered
- Order Reference Number
- Order Date
- Name of dealer contact, department and phone number

Once a representative confirms the information provided, the part will be released. If there is a concern regarding the information provided, a representative will contact the dealership. Please allow 2 - 3 days for part release after providing the requested information.

**Important Notes:**

- *Once you have placed your order DO NOT upgrade or change your order status.*
- *Failure to provide the above information within 48 hours will result in an order cancellation.*

Model Application	Part Number	Part Name	Qty./Unit
HS 250h	47050-75031	Cylinder Assembly, Brake Master with Fluid	1

**Warranty Reimbursement Procedures**

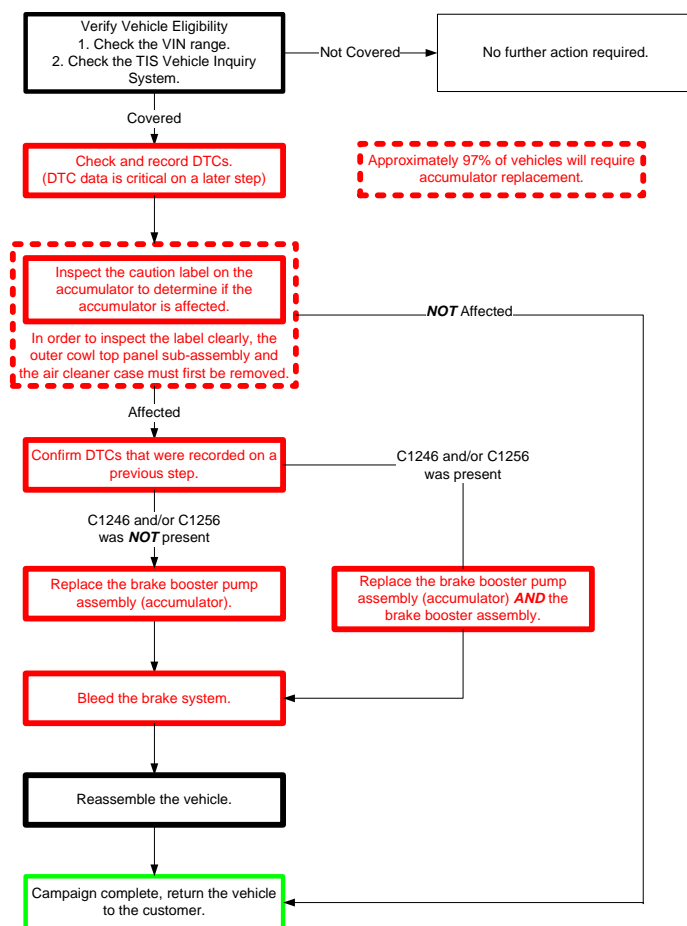

Model	Operation Code	Description	Flat Rate Hours
HS 250h	3530EB	Inspect brake booster pump assembly	0.7 hrs/vehicle
	3530ED	Inspect and replace brake booster pump assembly	3.3 hrs/vehicle

- The flat rate times include 0.1 hours for administrative cost per unit for the dealership.
- The cost of brake fluid (up to 2 liters) can be claimed up to \$40.00 per vehicle as sublet type "OF" under operation code 3530ED.

Lexus' usual customer care amenities of car wash and fuel tank fill apply to this Safety Recall. Additionally, one day of rental vehicle

expense (to a maximum of \$45/day) or the cost of pick-up and delivery or remote repair of the customer's vehicle may be claimed if required.



In the limited cases in which the condition has occurred and accumulator and actuator assembly requires replacement, the following operation code should be used:

Model	Op. Code	Description	Flat Rate Hour
HS 250h	3530EG	Inspect and Replace Brake Booster Pump Assembly w/ Master Cylinder	5.4 hrs/vehicle

- The flat rate times include 0.1 hours for administrative cost per unit for the dealership.
- The cost of Brake Fluid (up to 4 liters) can be claimed up to \$80.00 per vehicle as sublet type "OF" under Op Code 3530EG.

**Campaign Special Service Tools**

In a separate shipment, which is scheduled to arrive the week of July 22, 2013, your dealership was sent a package containing special service tools (SSTs) for this campaign. When received, the package will have a fluorescent (green, orange, yellow, or pink) label like the sample below for easy identification.

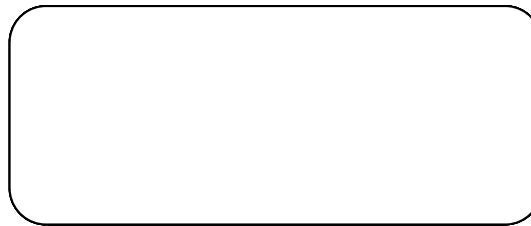

Tools included in the set:

Image	Name	Quantity	Image	Name	Quantity
	Rubber Caps	3		Bushing Holder	1
	Tube Remover (Small)	1		Pump Wrench	1
	Tube Remover (Large)	1		Nut Installer	1

## Repair Quality Confirmation

The repair quality of covered vehicles is extremely important to Lexus. To help ensure that all vehicles have the repair performed correctly, please designate at least one associate (someone other than the individual who performed the repair) to verify the repair quality of every vehicle prior to customer delivery.

## Media Contacts

It is imperative that all media contacts (local and national) receive a consistent message. In this regard, all media contacts must be directed to Cindy Knight (310) 468-2170 in Toyota Corporate Communications. (Please do not provide this number to customers. Please provide this contact to only media associates.)

## Customer Handling

A FAQ is attached to help you respond to any customer concerns. If the customer has any further questions, they are requested to contact the Lexus Customer Assistance Center. The Lexus Customer Assistance Center can be reached at 1-800-255-3987, Monday through Friday, 5:00 am to 6:00 pm, or Saturday 7:00 am through 4:00 pm Pacific Time.

Please review this remedy notification with your staff to assure that all relevant personnel have been informed with regard to this subject.

Thank you for your cooperation.

Lexus  
A Division of Toyota Motor Sales, U.S.A., Inc.

Attachments

CC: Customer Satisfaction Manager  
General Manager  
Parts Manager  
Pre-owned Manager  
Sales Manager  
Service Manager  
Warranty Administrator



Safety Recall DLD - **Remedy**  
 Certain 2010 Model Year HS 250h Vehicles  
 Brake Booster Pump Assembly (Accumulator)

**Q1:** *What is the condition?*

**A1:** The subject vehicles are equipped with a Brake Booster Pump Assembly which can develop a crack inside the accumulator housing. If this occurs, nitrogen gas could leak into the brake fluid and gradually cause a loss of power assist. Under certain circumstances, this could affect stopping distance and increase the risk of a crash.

**Q1a:** *What is the Brake Pressure Accumulator?*





**A1a:** Brake fluid is discharged by the Brake Booster Pump and passes through a check valve where it is then stored in the accumulator. The brake fluid that is stored in the accumulator provides the hydraulic pressure that is needed for brake operation.

**Q1b:** *What is the cause of the condition?*

**A1b:** The cause of this condition is insufficient strength of components inside the brake pressure accumulator.

**Q2:** *Are there any warnings that this condition exists?*

**A2:** Yes. You may notice a squeak from the engine compartment during brake application. Additionally, the brake pedal may have a longer stroke and/or spongy feeling. If this condition is present, the warning lights listed in the table below may illuminate and the skid control buzzer may sound.

Warning Lights	
	Brake System Warning Light (red indicator)
	Brake System Warning Light (yellow indicator)
	ABS Warning Light
	Master Warning Light

Please note that the warning lights shown above can also illuminate for conditions not related to this Safety Recall.

**Q3:** *What is Lexus going to do?*

**A3:** In late July, 2013, Lexus will send an owner notification by first class mail to owners of vehicles covered by this Safety Recall.

Lexus dealers will perform an inspection and, if necessary, replace the brake booster pump assembly (accumulator) at **NO CHARGE** to you.

**Q3a:** *How does Lexus obtain my mailing information?*

**A3a:** Lexus uses an industry provider who works with each state's Department of Motor Vehicles (DMV) to receive registration or title information, based upon the DMV records. Please make sure your registration or title information is correct.

**Q3b:** *Do I need my owner letter to have the remedy performed?*

A3b: You do not need an owner letter to have this recall completed; however, to assist the dealer in confirming vehicle eligibility, we request that you present this notice at the time of your service appointment.

**Q4:** *Which and how many vehicles are covered by this Safety Recall?*

A4: There are approximately 5,100 Lexus HS 250h (Certain 2010 Model Year) vehicles covered by this Safety Recall in the US.

Model Name	Model Year	Production Period	Approx. UIO
HS 250h	Certain 2010	Mid June, 2009 through Early October, 2009	5,100

**Q4a:** *Are there any other Toyota, Lexus or Scion vehicles covered by this Safety Recall in the U.S.?*

A4a: Yes, there are approximately 82,000 Toyota Prius (Certain 2010 Model Year) vehicles covered by this Safety Recall in the U.S.

**Q4b:** *Why aren't other Hybrid models covered by this Safety Recall?*

A4b: Other hybrid models utilize a brake booster pump assembly which is of a different design.

**Q5:** *What if I previously paid for repairs to my vehicle for this condition?*

A5: Reimbursement consideration instructions will be provided in the remedy owner letter.

**Q6:** *What if I have additional questions or concerns?*

A6: If you have additional questions or concerns, please contact the Lexus Customer Assistance Center at 1-800-255-3987, Monday through Friday, 5:00 am to 6:00 pm, or Saturday 7:00 am through 4:00 pm Pacific Time.



Certain 2010 Model Year HS 250h Vehicles  
Brake Booster Pump Assembly (Accumulator)  
**SAFETY RECALL NOTICE**

**URGENT SAFETY RECALL**  
This is an important Safety Recall.  
The remedy will be performed at  
**NO CHARGE** to you.

[VIN]

Dear Lexus Owner:

This notice is being sent to you in accordance with the requirements of the National Traffic and Motor Vehicle Safety Act. Lexus has decided that a defect, which relates to motor vehicle safety, exists in certain 2010 HS 250h vehicles.

You have received this notice because our records, which are primarily based on state registration and title data, indicate that you are the current owner.

**What is the Condition?**

The subject vehicles are equipped with a Brake Booster Pump Assembly which can develop a crack inside the accumulator housing. If this occurs, nitrogen gas could leak into the brake fluid and gradually cause a loss of power assist. Under certain circumstances, this could affect stopping distance and increase the risk of a crash.

**What will Lexus do?**

Lexus dealers will perform an inspection and, if necessary, replace the Brake Booster Pump Assembly (Accumulator) at **NO CHARGE** to you.

**What should you do?**

*This is an important Safety Recall*

Please contact any authorized Lexus dealer to schedule an appointment to have the inspection performed as soon as possible.

Depending upon the inspection result, the repair can take up to approximately **four hours**. However, depending on the dealer's work schedule, it may be necessary to make your vehicle available for a longer period of time.

You do not need an owner letter to have this recall completed; however, to assist the dealer in confirming vehicle eligibility, we request that you present this notice at the time of your service appointment.

If you would like to update your vehicle ownership or contact information, you may do so by registering at [www.lexus.com/ownersupdate](http://www.lexus.com/ownersupdate). You will need your full 17-digit Vehicle Identification Number (VIN) to input the new information.

**What if you have other questions?**

*Your local Lexus dealer will be more than happy to answer any of your questions and set up an appointment to perform the repair.* You can find additional information and locate a Lexus dealer in your area by going online and visiting [www.lexus.com](http://www.lexus.com). If you require further assistance, you may contact the Lexus Customer Assistance Center at 1-800-255-3987, Monday through Friday, 5:00 am to 6:00 pm, Saturday 7:00 am through 4:00 pm Pacific Time.

If you believe that the dealer or Lexus has failed or is unable to remedy the defect within a reasonable time, you may submit a complaint to the Administrator, National Highway Traffic Safety Administration, 1200 New Jersey Avenue S.E., Washington, D.C. 20590, or call the toll free Vehicle Safety Hot Line at 1-888-327-4236 (TTY: 1-800-424-9153), or go to <http://www.safercar.gov>.

**What if you have previously paid for repairs to your vehicle for this specific condition?**

If you have previously paid for repair to your vehicle for this specific condition prior to receiving this letter, please mail a copy of your repair order, proof-of-payment and proof-of-ownership to the following address for reimbursement consideration:

Lexus, a Division of Toyota Motor Sales, U.S.A., Inc  
Lexus Customer Assistance Center L201  
19001 South Western Avenue  
Torrance, CA 90509

If you are a vehicle lessor, Federal law requires that any vehicle lessor receiving this recall notice must forward a copy of this notice to the lessee within ten days.

We have sent this notice in the interest of your continued satisfaction with our products, and we sincerely regret any inconvenience this condition may have caused you.

Thank you for driving a Lexus.

Sincerely,

LEXUS, A DIVISION OF TOYOTA MOTOR SALES, U.S.A., INC.

**TECHNICAL INSTRUCTIONS**  
**FOR**  
**SAFETY RECALL DLD**  
**BRAKE BOOSTER PUMP ASSEMBLY (ACCUMULATOR)**  
**CERTAIN 2010 MODEL YEAR HS250h**

[Complete D0H Technical Video Supplement](#)

## I. OPERATION FLOW CHART

The flow chart is for reference only. **DO NOT** use it in place of the full technical instructions. Follow **ALL** steps as outlined in the full technical instructions to confirm the campaign is completed correctly.

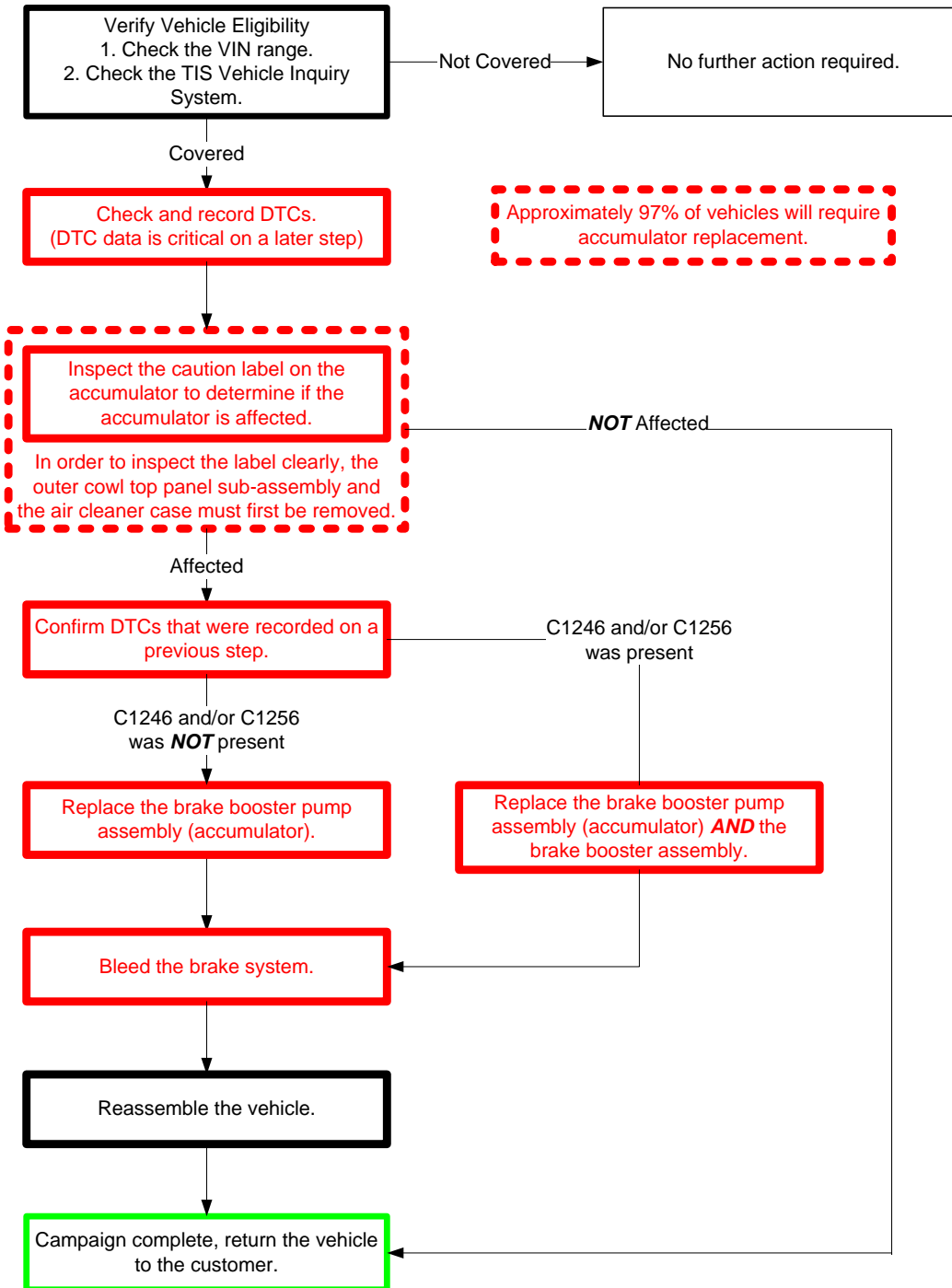

## II. BACKGROUND

The subject vehicles are equipped with brake pressure accumulators consisting of a metal plunger containing brake fluid encased in a metal housing. The plunger is designed with metal pleated bellows to allow for motion. Nitrogen gas is sealed between the plunger and housing. There is a possibility that a fatigue crack could develop in the bellows due to the vertical vibration of the plunger while driving. If this occurs, nitrogen gas could leak into the brake fluid and gradually cause the brake pedal stroke to become longer, resulting in decreased hydraulic pressure. Under certain circumstances, this condition could affect stopping distance and increase the risk of a crash.

### III. IDENTIFICATION OF AFFECTED VEHICLES

#### A. COVERED VIN RANGE

WMI	Year	VIN Range	
		VDS	Range
JTH	2010	BB1BA	2000186-2009302

**NOTE:**

- Check the TIS Vehicle Inquiry System to confirm the VIN is involved in this Safety Recall, and that the campaign has not already been completed prior to dealer shipment or by another dealer.
- TMS warranty will not reimburse dealers for repairs conducted on vehicles that are not affected or were completed by another dealer.

### IV. PREPARATION

#### A. PARTS

**The majority of vehicles (approximately 97%) will require the replacement of this part.**

Part Number	Part Description	Quantity
04002-20247	Pump Assy, Brake Booster w/Accumulator Kit*	1
*The kit above includes the following parts.		
47070-47060	Pump Assy, Brake Booster w/Accumulator	1

**Only a very small number of vehicles will require the replacement of this part, follow the inspection procedure in these instructions to determine if replacement is required. Parts will be on MAC, refer to the dealer letter for details.**

Part Number	Part Description	Quantity
47050-75031	Cylinder Assembly, Brake Master with Fluid	1
44785-02060	Brake Booster Gasket	1
90468-16142	Clip	1

#### B. MATERIALS

- DOT3 brake fluid: approximately 2 liters for accumulator replacement (4 liters if also replacing master cylinder)

#### C. TOOLS & EQUIPMENT

- Standard hand tools
- Torque wrench
- Protective tape
- Molding remover set
- Techstream
- Paper towels

**SST** – This is an essential special service tool that the dealership should have.

Part Number	Part Name
00002-02955	Beam Torque Wrench

**CAMPAIGN TOOLS** – These tools are provided to the dealership. These tools are necessary when performing this repair.

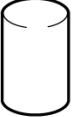
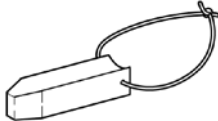
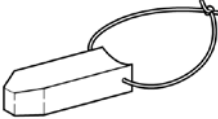
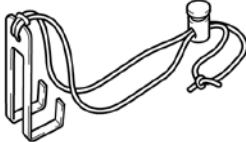

Image	Name	Quantity
	Rubber Caps	3
	Tube Remover (Small)	1
	Tube Remover (Large)	1

Image	Name	Quantity
	Bushing Holder	1
	Pump Wrench	1
	Nut Installer	1

**NOTE:** These tools **CANNOT** be ordered through the parts or tools system. There is a very limited supply of tools, but if additional tools are needed, contact your regional representative.

## V. SAFETY PRECAUTIONS

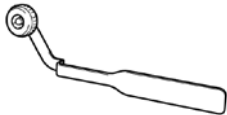

### CRITICAL INFORMATION – READ THOROUGHLY



These cautions should be observed when performing this campaign. Failure to follow these cautions could result in damaged parts or inadequate repair quality.

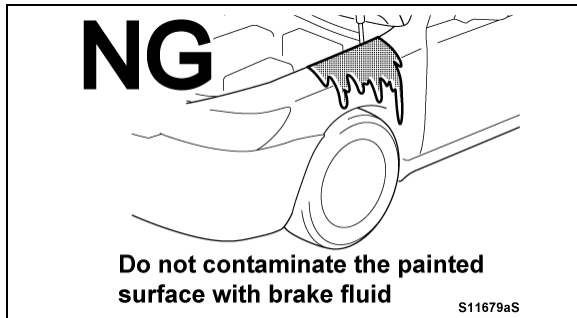

#### 1. HANDLE BRAKE FLUID CAREFULLY

- DO NOT** allow brake fluid to contact any painted surfaces or the paint may be damaged.
- ALWAYS** use paper towels when disconnecting and reconnecting brake lines to prevent spillage.



#### 2. DO NOT USE CLOTH RAGS OR GLOVES

- DO NOT** use any fabric near the open brake system components to avoid threads and fibers from entering the braking system.

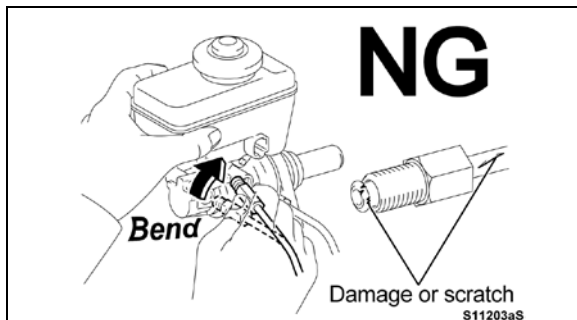

#### 3. HANDLE THE BRAKE TUBES CAREFULLY

- DO NOT** deform or damage the brake tubes during removal or installation.

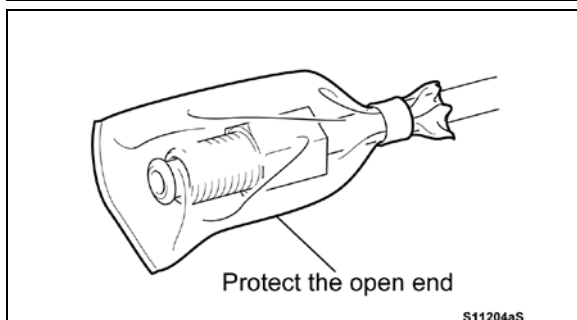

#### 4. PROTECT THE BRAKE SYSTEM

- Clean components prior to disassembly to avoid contamination.
- Cover open components to avoid contamination.

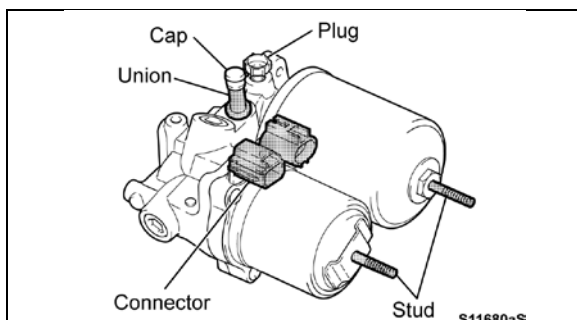

#### 5. HANDLE BRAKE BOOSTER CAREFULLY

- If the new accumulator is dropped, **DO NOT** use.
- To avoid damage, **DO NOT** carry the accumulator by the union, connectors, or studs.
- The new accumulator is filled with brake fluid, **DO NOT** remove the plugs until installed.

## VI. COMPONENTS

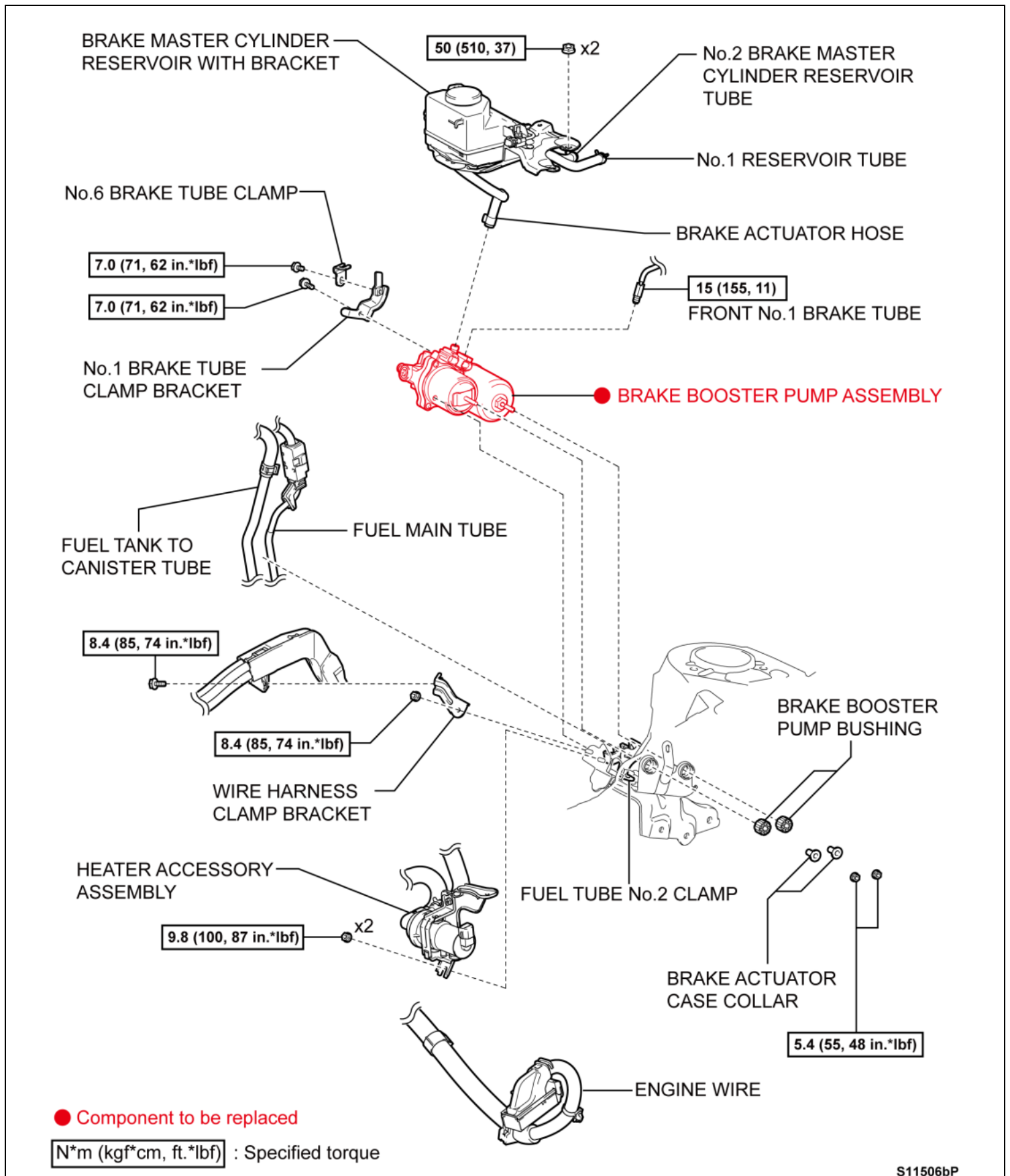

S11506bP

## VII. ACCUMULATOR CAUTION LABEL INSPECTION

### [Video Supplement: Introduction & Inspection](#)

#### 1. CHECK AND RECORD DTCs

- Check and record any DTCs.



It is critical to record DTCs on this step, they will be referenced on a later step to determine if additional parts replacement is required.

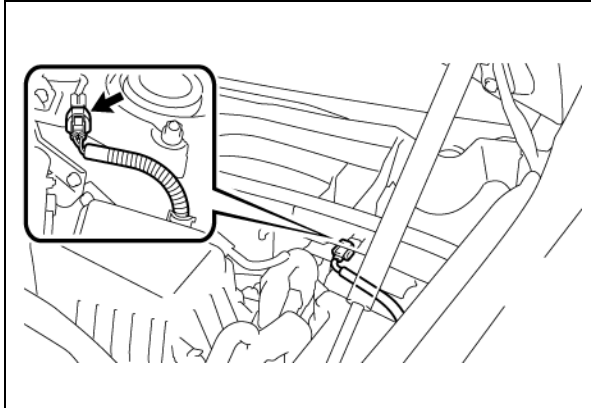

#### 2. DISABLE THE BRAKE CONTROL SYSTEM

- Turn the IG OFF and apply the parking brake.
- Wait 2 minutes.



- It takes 2 minutes for the brake control system to become disabled. **DO NOT** proceed to the next step until 2 minutes have elapsed or air may enter the brake system when the battery is reconnected.
- DO NOT** operate the brake pedal or any doors while waiting for the 2 minutes to elapse.

- Disconnect the reservoir level switch connector.

#### 3. DISCONNECT THE NEGATIVE BATTERY CABLE

- Remove the luggage compartment floor mat.
- Open the luggage compartment trim cover.
- Disconnect the battery cable.

**NOTE:** The luggage door may lock when the battery is disconnected.



- DO NOT** reconnect the battery until instructed or air could enter the accumulator and damage the pump.

#### 4. RELEASE THE PRESSURE FROM THE ACCUMULATOR

- Depress the brake pedal 40 times or more to discharge all internal pressure from the accumulator.

**NOTE:** The brake pedal should become very stiff.





## 5. REMOVE THE OUTER COWL TOP PANEL SUB-ASSEMBLY

a) Refer to [TIS](#) for removal instructions.

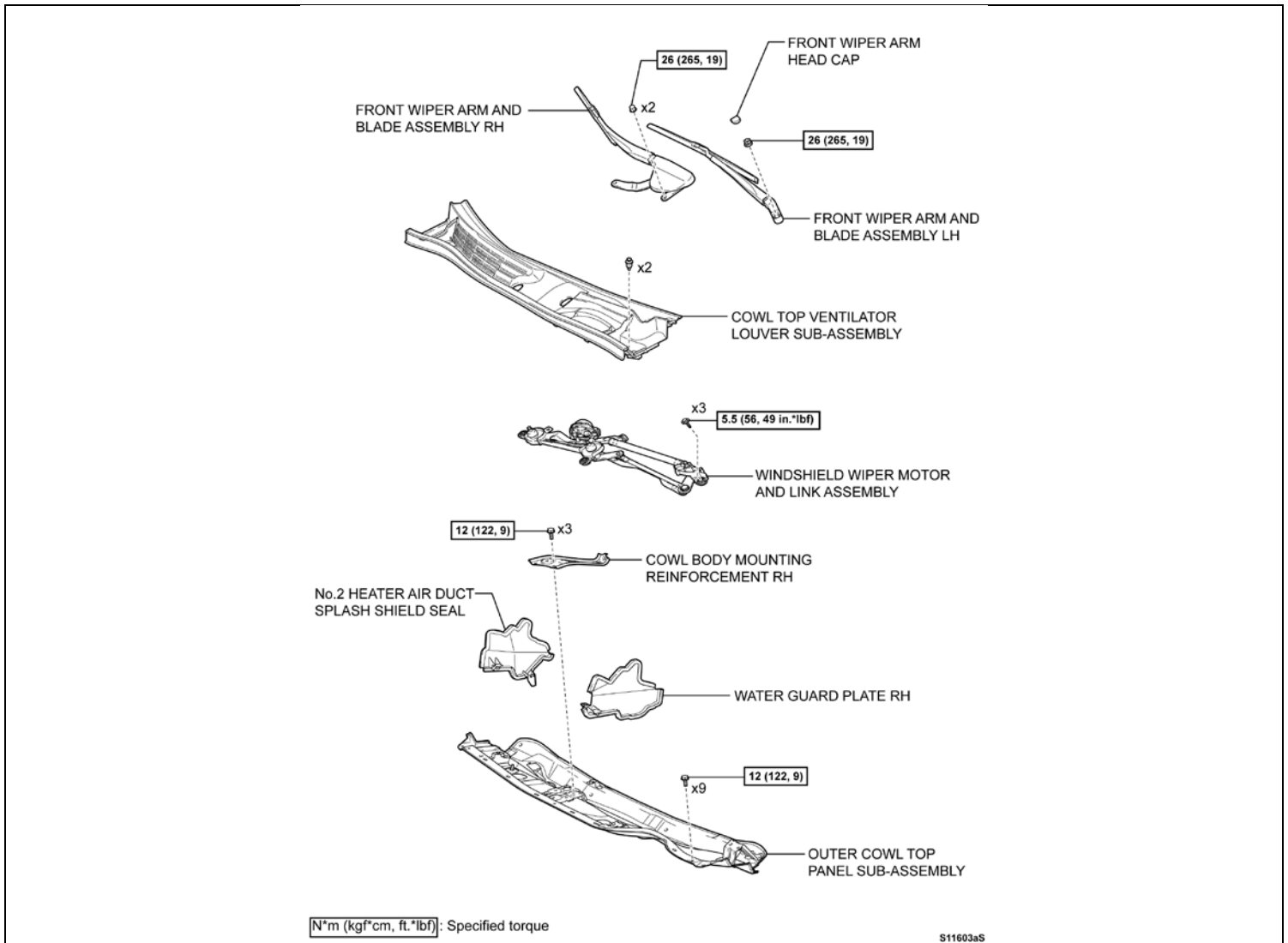

## 6. REMOVE THE AIR CLEANER CASE

a) Refer to [TIS](#) for removal instructions.

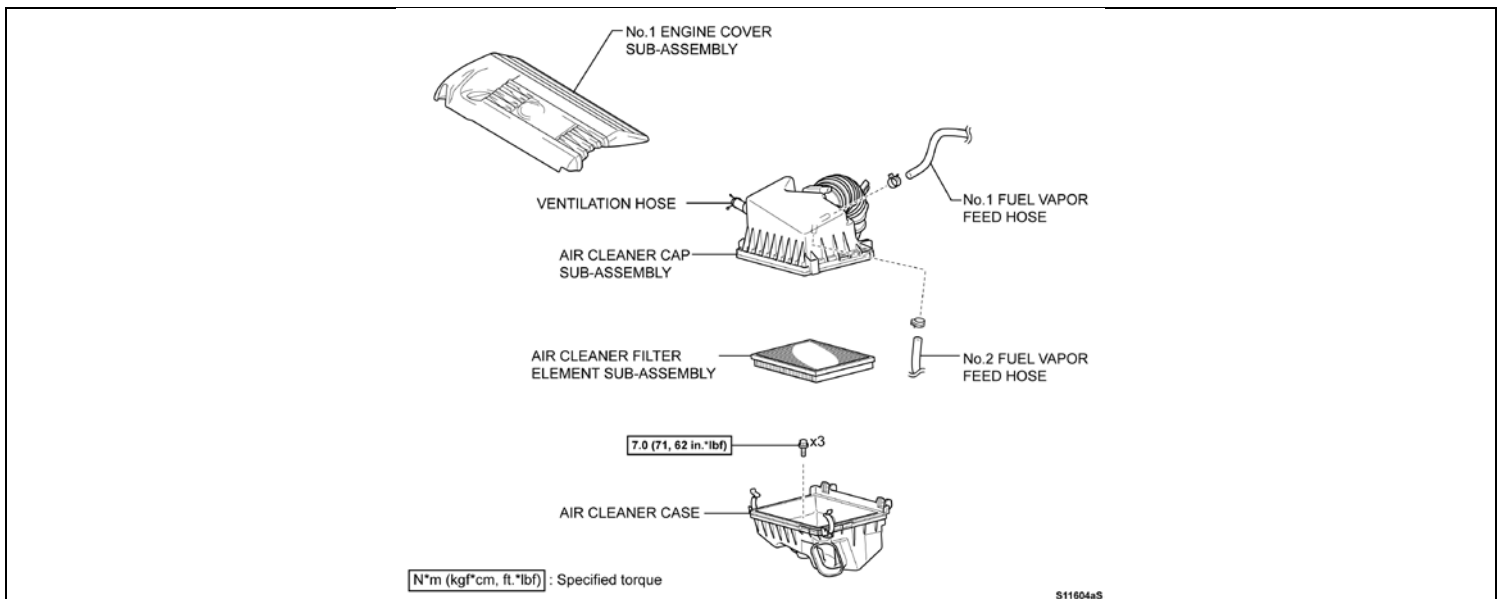

## 7. INSPECT THE ORIENTATION OF THE ACCUMULATOR CAUTION LABEL

- a) Inspect the orientation of the caution label to determine if the accumulator requires replacement.

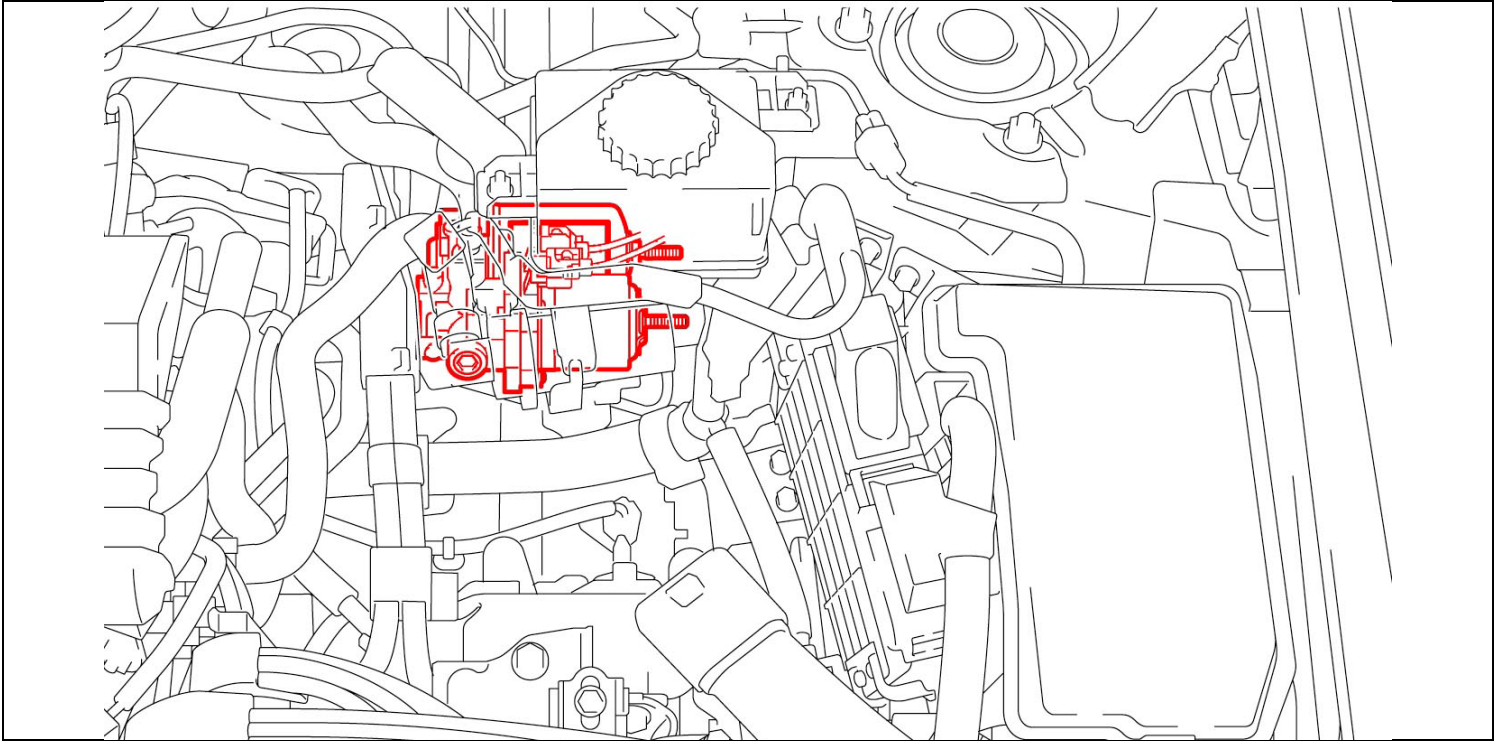

### CONDITION 1

Label is **HORIZONTAL** on accumulator  
Accumulator replacement **REQUIRED**

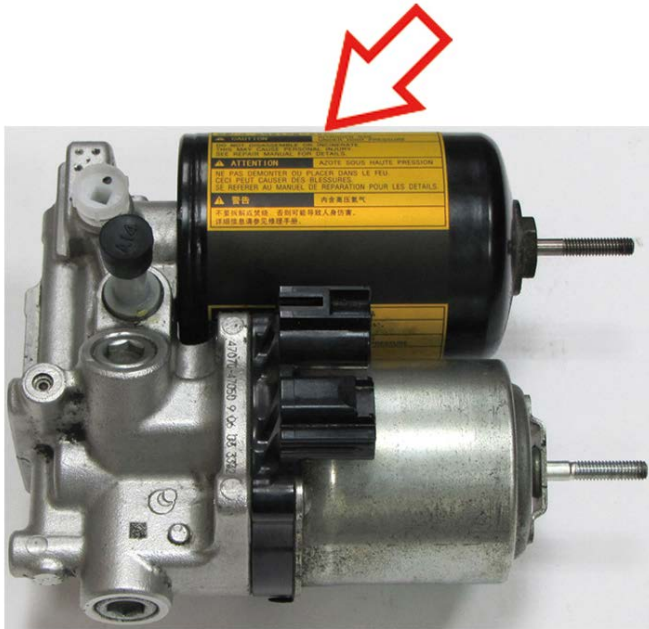

The accumulator is affected and replacement is required. Proceed to **SECTION VIII**. To determine if additional parts require replacement.

### CONDITION 2

Label is **VERTICAL** on accumulator  
**NO NEED** to replace accumulator

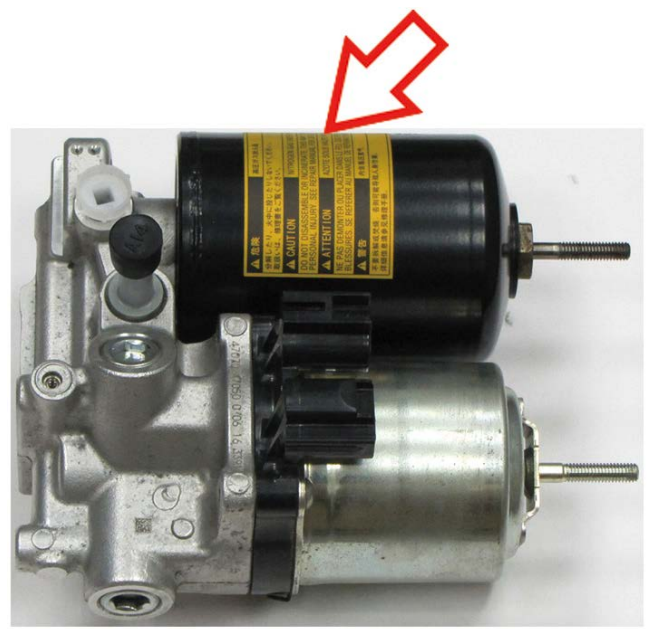

The accumulator **IS NOT** affected and **DOES NOT** need to be replaced. Reassemble the vehicle, then proceed to **SECTION XIII**. for instructions on ISC initialization.

**NOTE:** There is only a small percentage of vehicles that will not require accumulator replacement.

## VIII. DTC CONFIRMATION

### CONDITION 3

**C1246 and/or C1256 was found during DTC inspection step.**

The accumulator may have potentially leaked nitrogen gas into the brake booster assembly; therefore, the Brake booster assembly must also be replaced.

Replace the brake booster assembly as per the repair manual when replacing the accumulator. Proceed to **SECTION IX.**

### CONDITION 4

**C1246 AND C1256 WERE NOT** found during DTC inspection step.

**ONLY** accumulator replacement is required. Proceed to **SECTION IX.**

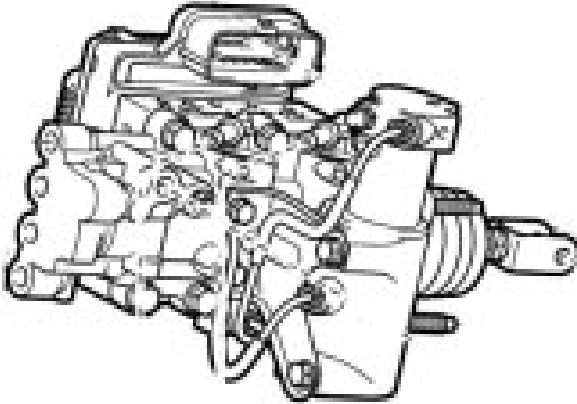

**BRAKE BOOSTER  
ASSEMBLY**

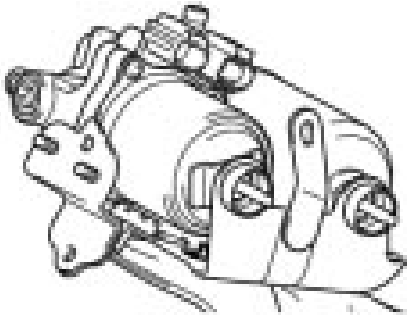

**BRAKE BOOSTER PUMP  
ASSEMBLY (ACCUMULATOR)**

## IX. ACCUMULATOR REMOVAL

### [Video Supplement: Accumulator Removal](#)

#### 1. REMOVE BRAKE FLUID

- Remove some brake fluid from the reservoir to prevent spillage.



- DO NOT** use a fluid extractor that has been used on anything other than brake fluid to avoid contamination.
- DO NOT** allow brake fluid to contact any painted surfaces.

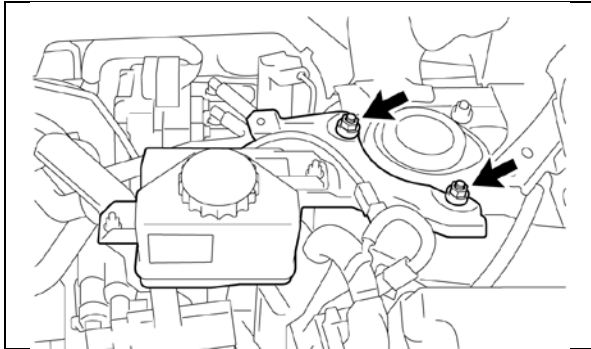

#### 2. DISCONNECT THE MASTER CYLINDER RESERVOIR WITH BRACKET

- Remove the 2 nuts and detach the reservoir with bracket.

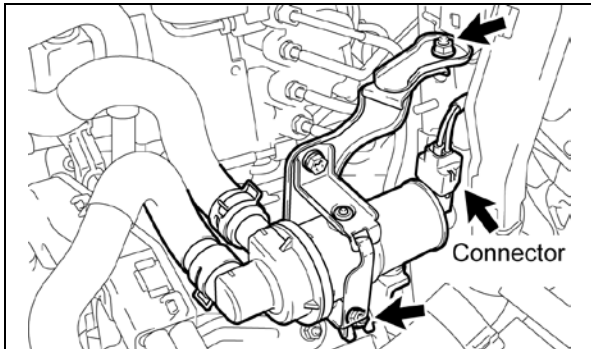

#### 3. DISCONNECT THE HEATER ACCESSORY ASSEMBLY

- Disconnect the connector.
- Remove the 2 nuts and detach the heater accessory.
- Position the heater accessory out of the way of the work area.

**NOTE:** *DO NOT* put excessive force of the coolant hoses.

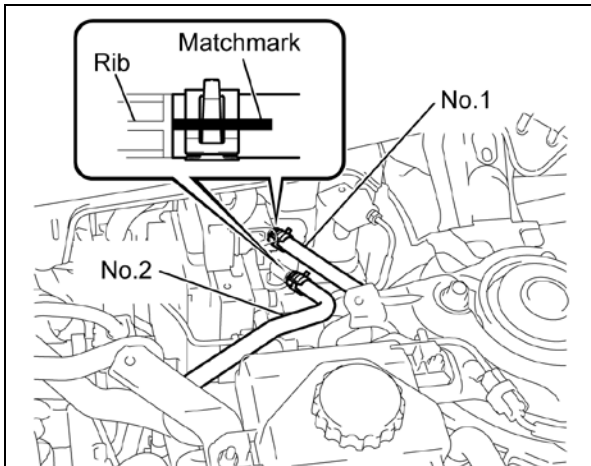

#### 4. DISCONNECT THE No.1 RESERVOIR AND No.2 BRAKE MASTER CYLINDER RESERVOIR TUBES

- Place matchmarks on the tubes that align with the ribs on the booster. These will be used during reassembly.

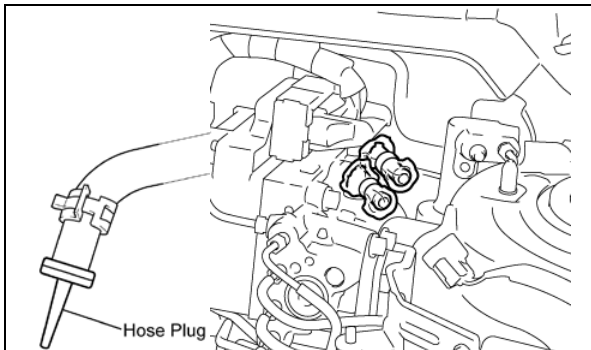

- Disconnect and immediately plug the hoses.
- Cover the lines on the booster to prevent contamination.

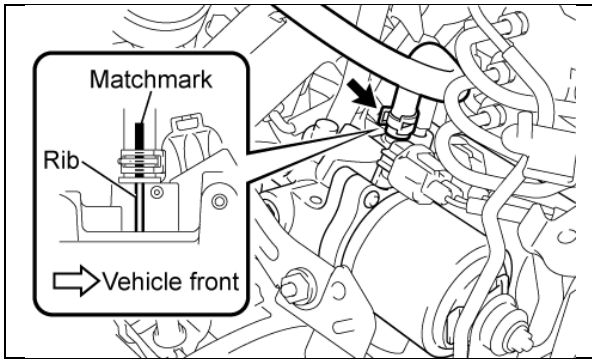

**5. DISCONNECT THE BRAKE ACTUATOR HOSE**

- a) Place a matchmark on the hose that aligns with the rib on the accumulator. This will be used during reassembly.
- b) Disconnect and immediately plug the hose.

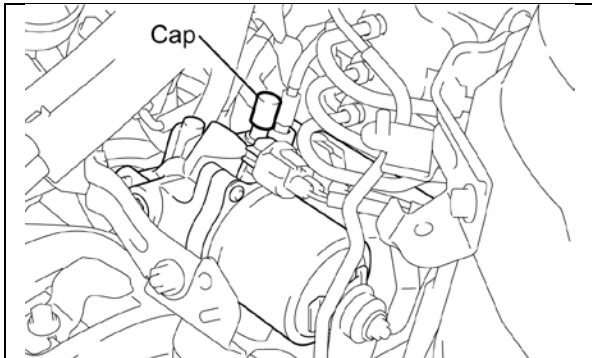

- c) Plug the line of the accumulator with the cap that was supplied in the tool kit.

**6. COMPLETELY REMOVE THE BRAKE MASTER CYLINDER RESERVOIR WITH BRACKET**

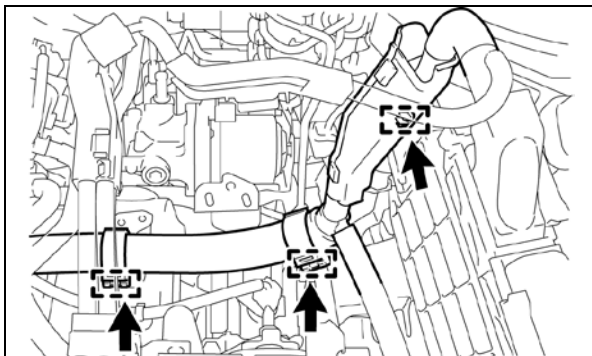

**7. DISCONNECT THE ENGINE HARNESS**

- a) Disconnect the 3 clamps.

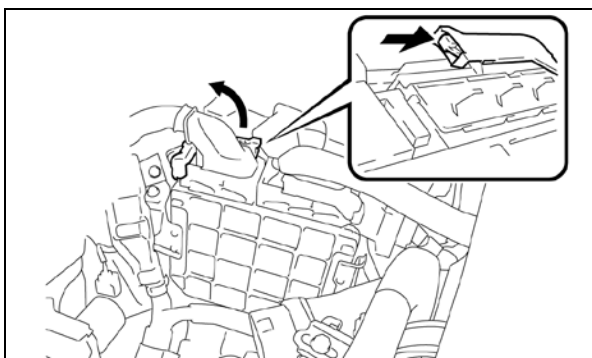

- b) Press the lock on the lever and lift to disconnect the hybrid vehicle control ECU connector.

**NOTE: DO NOT allow moisture or debris to contaminate the open connectors.**

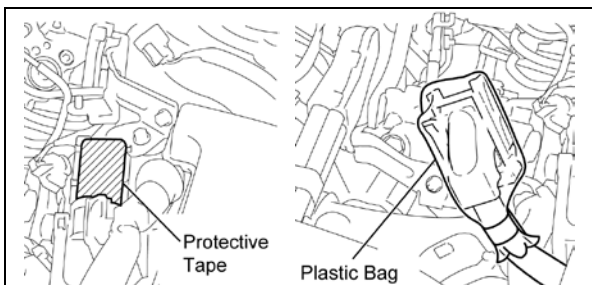

- c) Protect the ECU connector with tape.
- d) Protect the harness connector with a plastic bag.

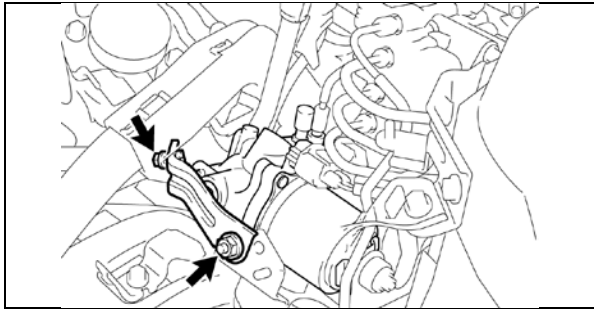

**8. REMOVE THE WIRE HARNESS CLAMP BRACKET**

a) Remove the bolt and nut then remove the bracket.

**NOTE: DO NOT deform the bracket.**

**9. SEPARATE THE FUEL LINES**

- a) Press the small tube remover (campaign tool) against the main tube.
- b) Slide the remover into the clamp to disengage the clamp claw.
- c) Hold the remover and pull the tube from the clamp.
- d) Use the large tube remover (campaign tool) to separate the canister tube.

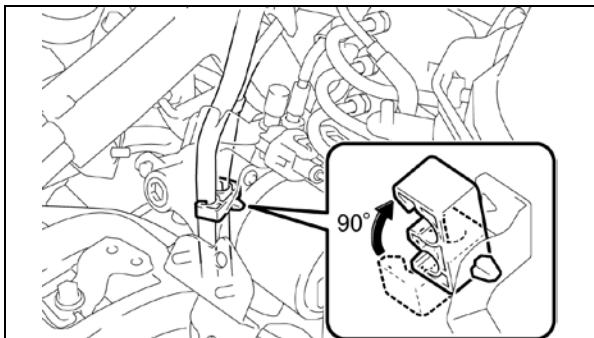
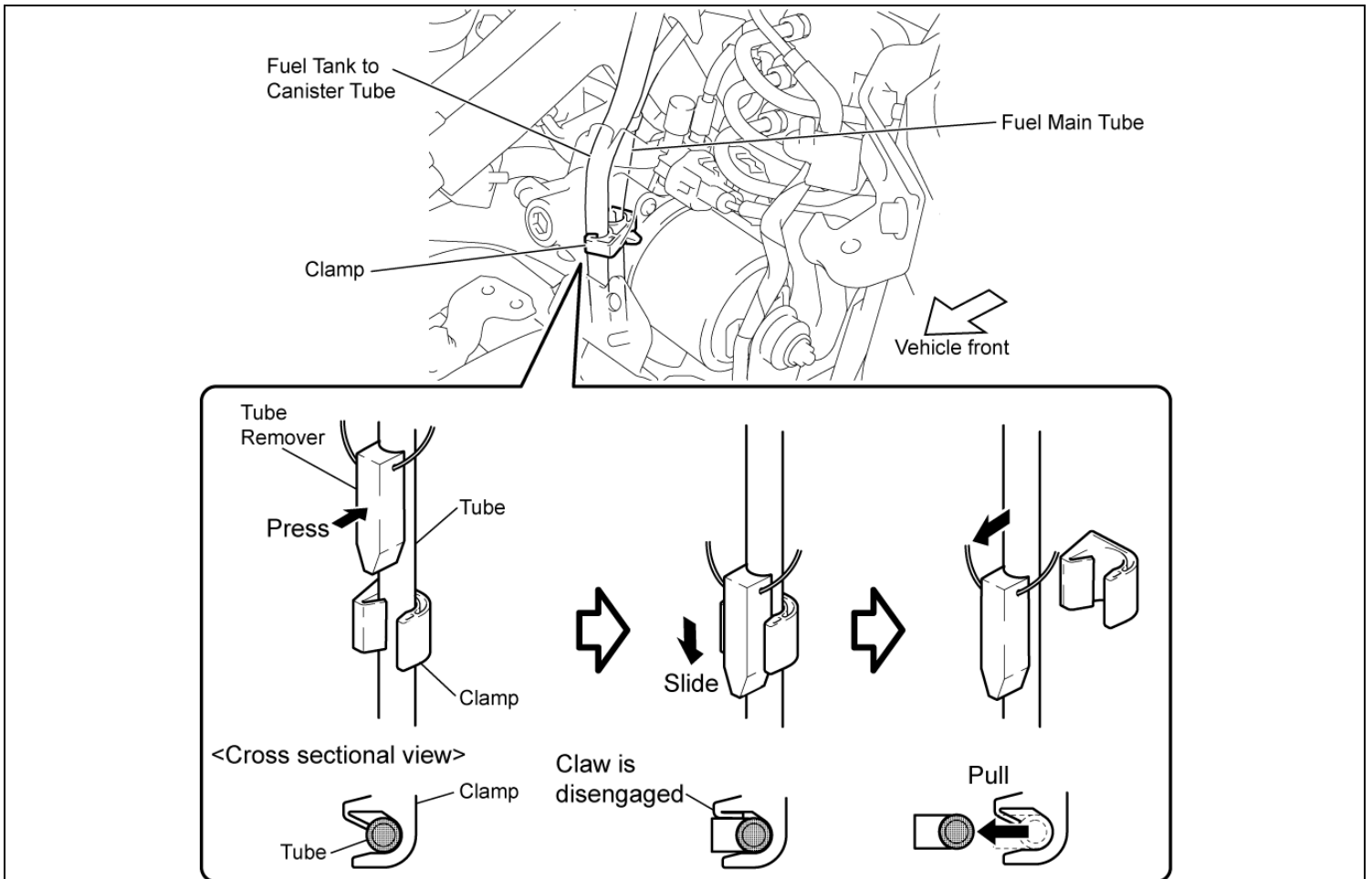

e) Rotate the clamp 90 degrees to prevent the tubes from being engaged.

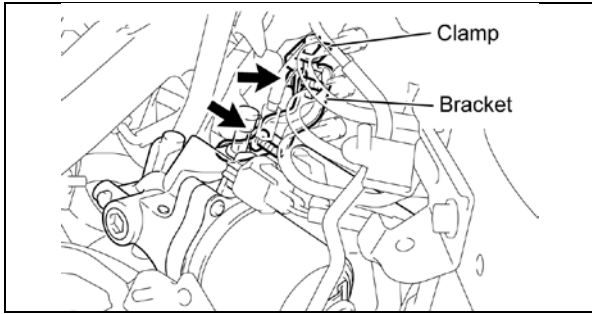

### 10. DISCONNECT THE FRONT No.1 BRAKE TUBE

- a) Remove the upper bolt to remove the clamp.
- b) Remove the lower bolt to remove the bracket.
- c) Disconnect the brake tube from the accumulator.
- d) Place a bag over the tube to prevent contamination.

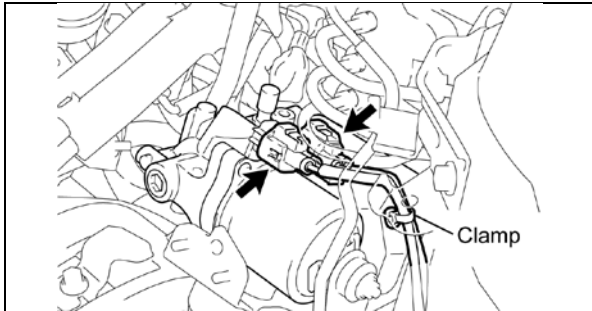
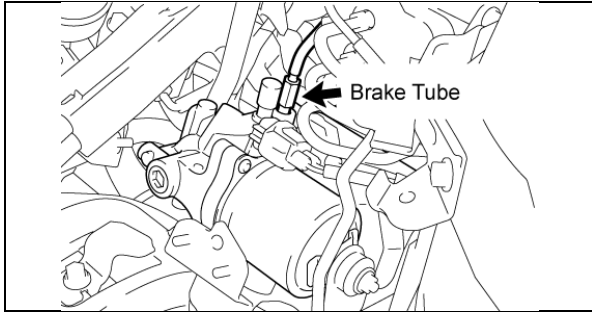

### 11. DISCONNECT THE ACCUMULATOR CONNECTORS

- a) Disconnect the 2 connectors.
- b) Disengage the clamp.

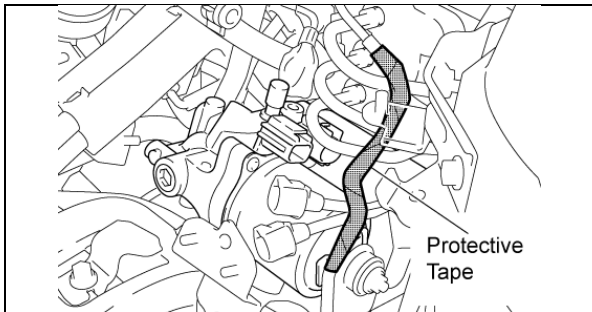

### 12. PROTECT THE BRAKE TUBE

- a) Wrap the brake tube to prevent damage during accumulator removal.

### 13. REMOVE THE ACCUMULATOR MOUNTING NUTS

- a) Use the brake pump wrench (campaign tool) to remove the 2 accumulator mounting nuts.



- Position the wrench under the harness to avoid damage.
- Use a magnet to retrieve the nuts after they are loosened to avoid losing them.

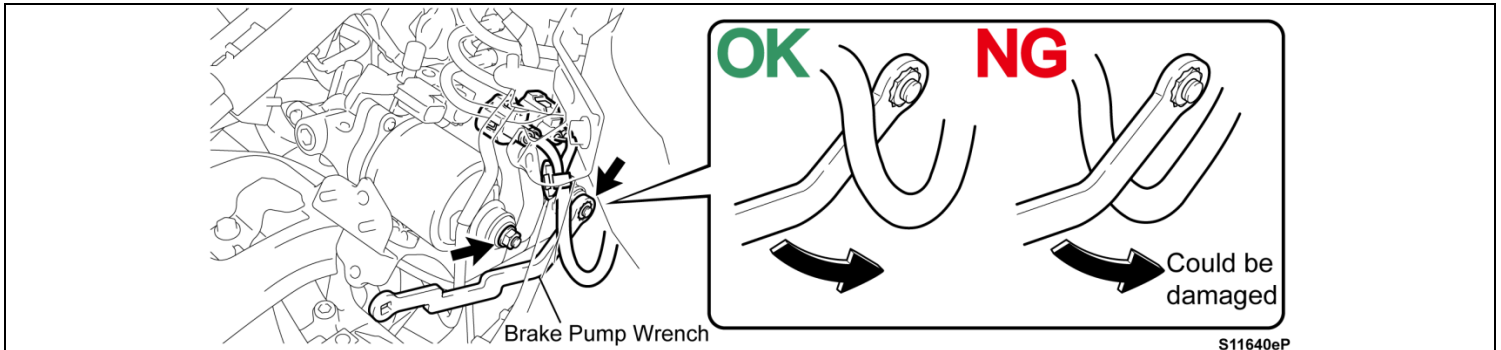

S11640eP

#### 14. REMOVE THE MOUNTING BUSHINGS AND COLLARS

- a) Move the pump towards the right side of the vehicle to allow for the removal of the bushings and collars.
- b) Remove the 2 bushings and 2 collars, then reposition the pump to its original place.

**NOTE: Use a magnet to retrieve the collars to avoid losing them.**

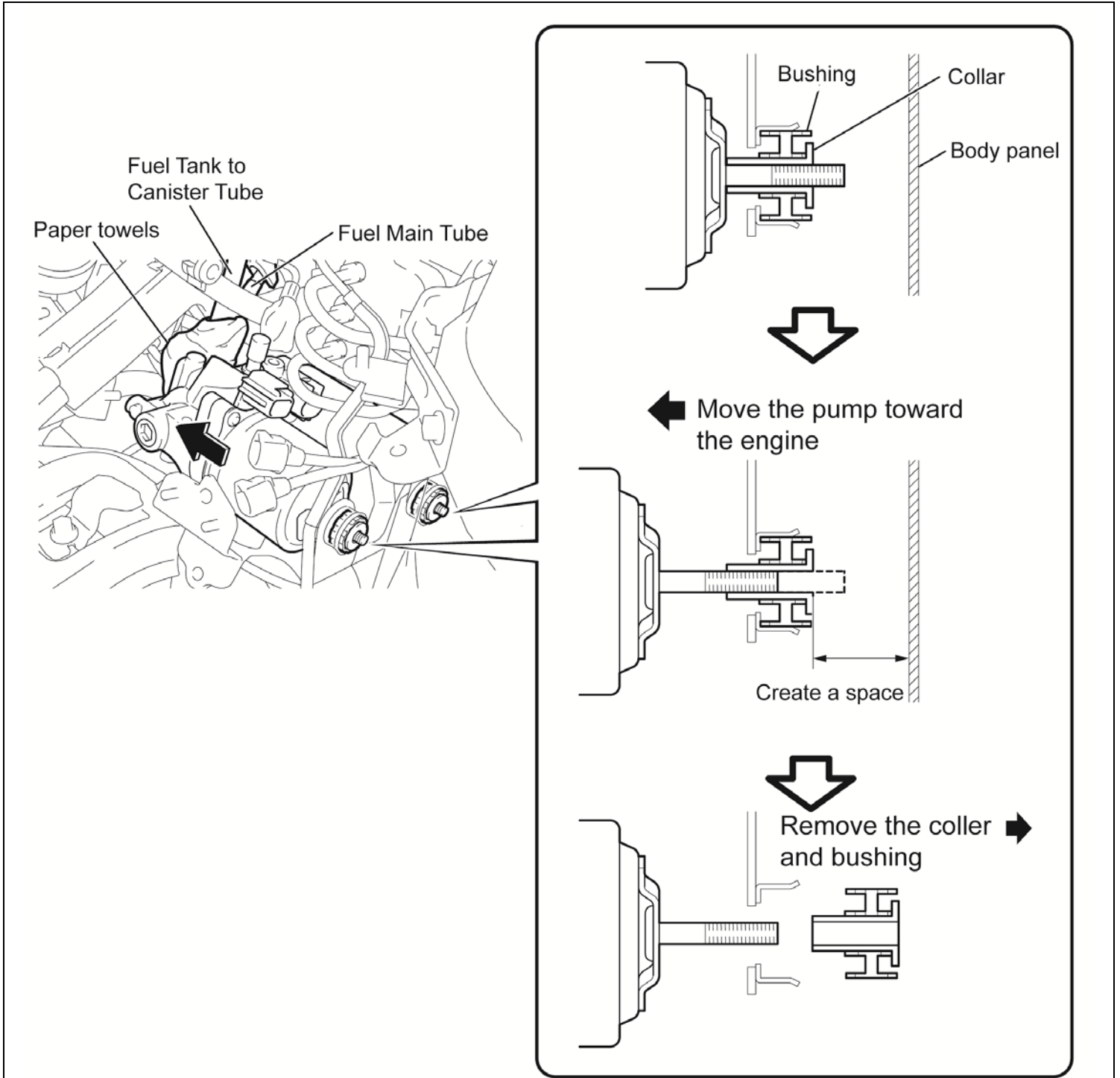



## 15. REMOVE THE ACCUMULATOR

a) Set the bushing holder (campaign tool) into place by following the directions on the illustration.

**NOTE: If the bushing holder is not set correctly, the bushing and collar will fall off and may be lost.**

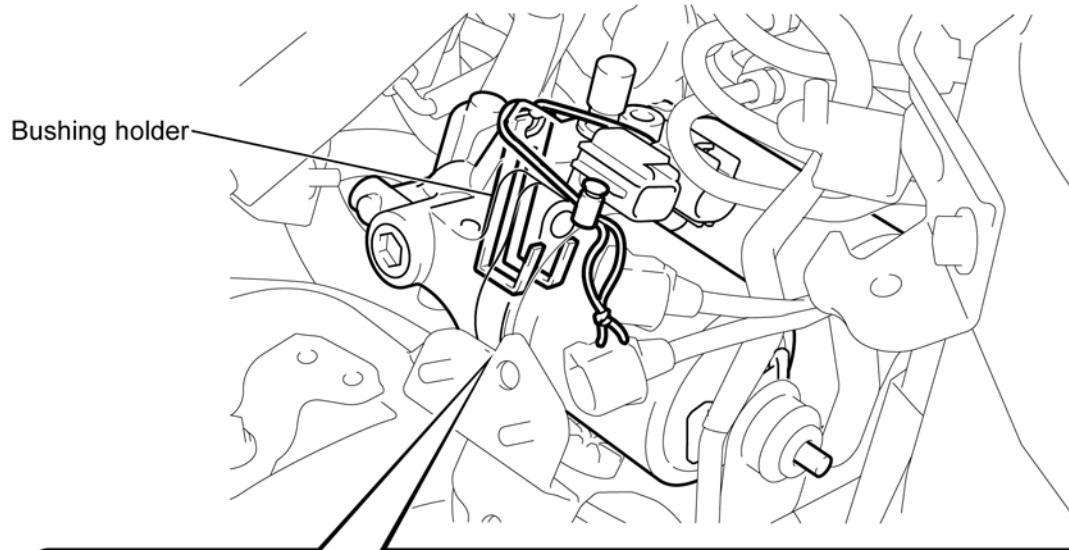

① Set a bushing holder as shown in the illustration.

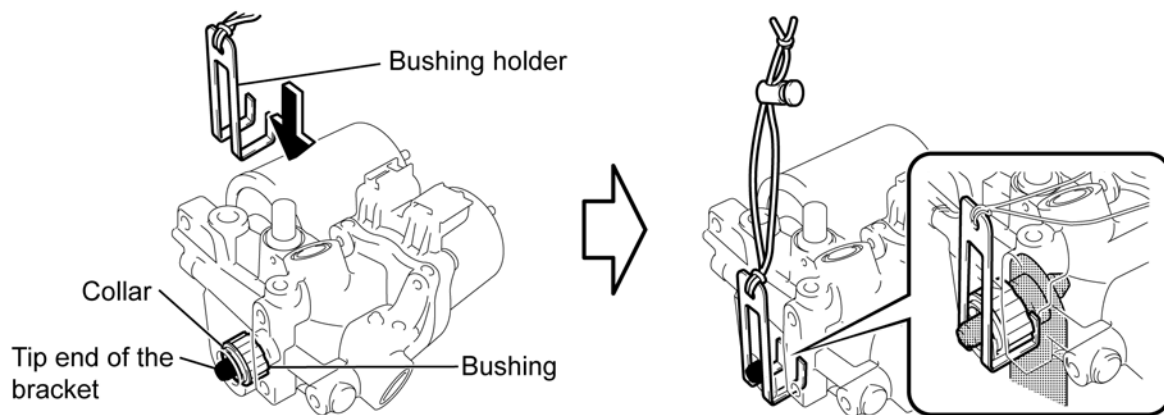

② Hook the loop of string at the connectors on the pump, and fix the holder with the stopper of the string.

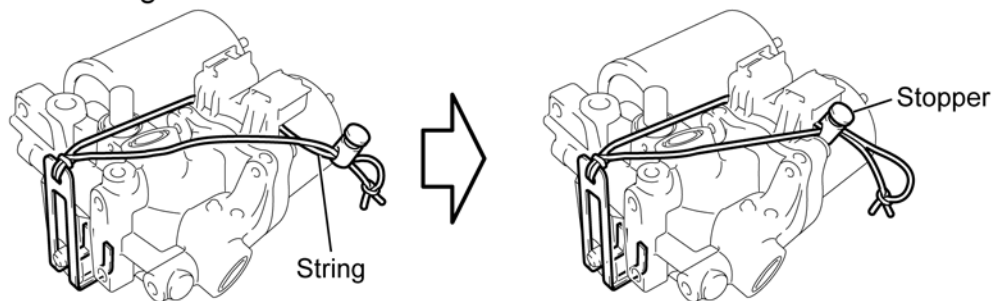

b) Remove the accumulator from the vehicle by following the directions on the illustration.



- To avoid damaging surrounding components, remove the pump carefully.
- Avoid disturbing the bushing holder string.

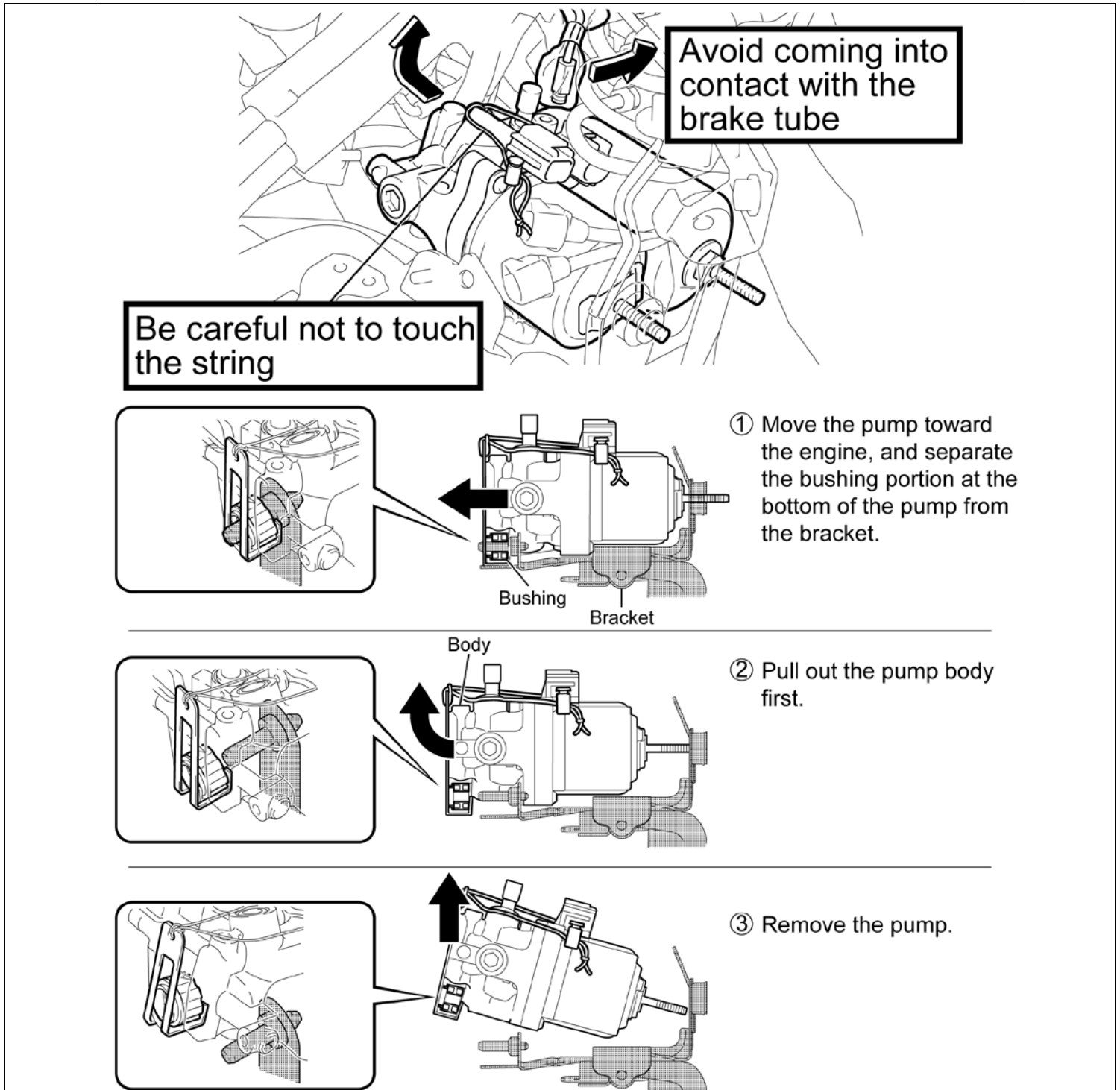

c) Remove the bushing holder.

d) Mark the old pump so it is not reused.

## X. ACCUMULATOR INSTALLATION

### [Video Supplement: Accumulator Installation & Old Accumulator Disposal](#)

#### 1. CONFIRM THE COLLAR AND BUSHING

- Confirm the bushing and collar (included with new part) are installed securely.

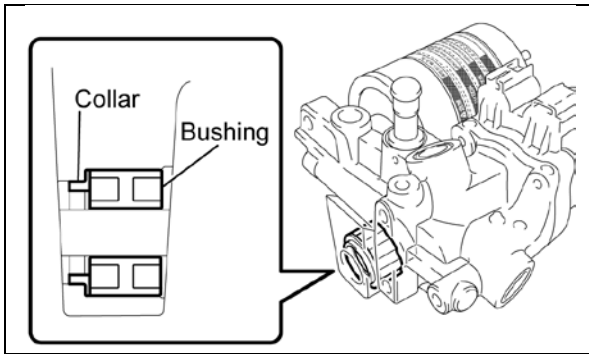

#### 2. POSITION THE **NEW** PUMP IN THE BRACKET

- Position the **NEW** pump in the bracket by following the directions on the illustration.



- To avoid damaging surrounding components, install the pump carefully.
- If the new pump is installed incorrectly the bushing may be damaged, if too much resistance is felt during installation confirm the bushing is not damaged.

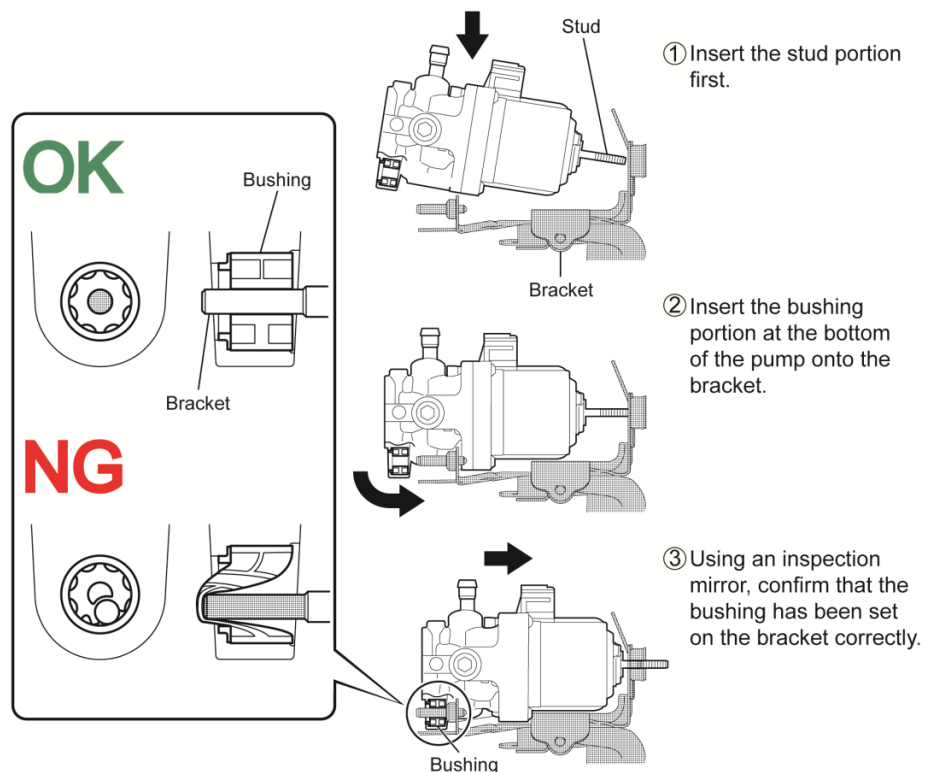
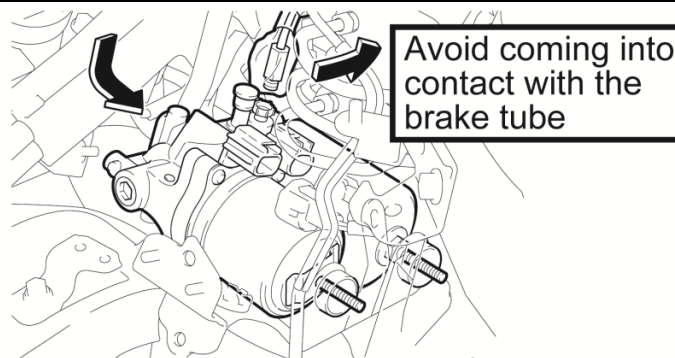

Move the pump toward the engine

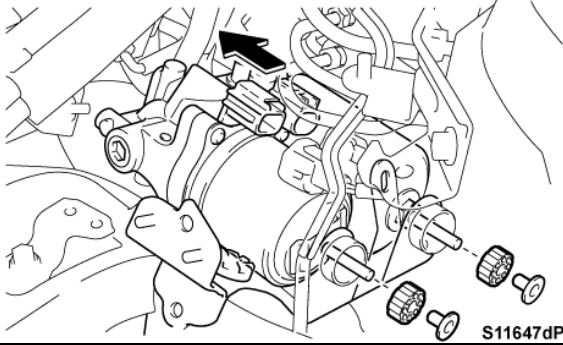

### 3. INSTALL THE BUSHINGS AND COLLARS

- a) Move the pump towards the right side of the vehicle to allow for the installation of the bushings and collars.
- b) Install the 2 bushings and 2 collars, then reposition the pump to its original place.

**NOTE:** To ease bushing and collar installation, follow these steps.

- 1) Slide to collar out of the bushing slightly.
- 2) Use a magnet to hold the bushing and collar.
- 3) Install the bushing and collar.

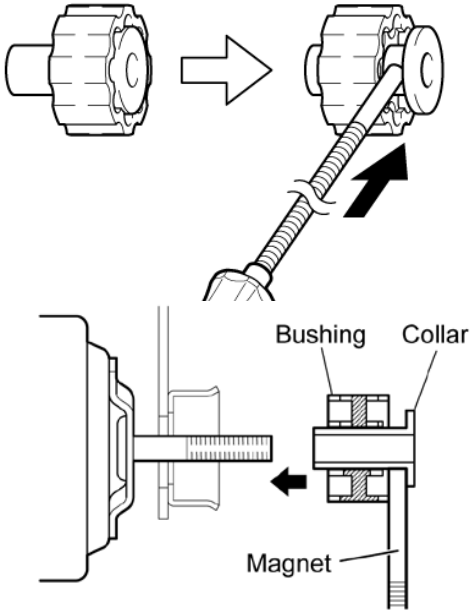

### 4. INSTALL THE ACCUMULATOR MOUNTING NUTS

- a) Use the nut holder (campaign tool) to loosely install the nut closest to the bulkhead.

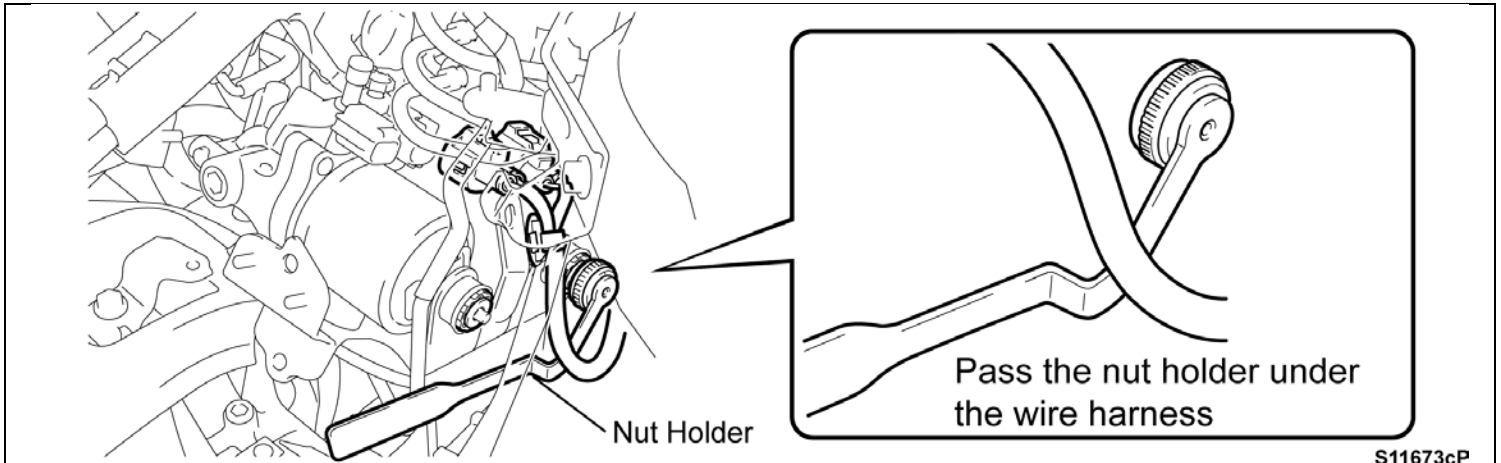

**NOTE:**

- Follow this illustration for instructions on how to use the nut holder.
- It may be necessary to press the accumulator towards the left side of the vehicle to ease installation of the nuts.

### How to use the nut holder

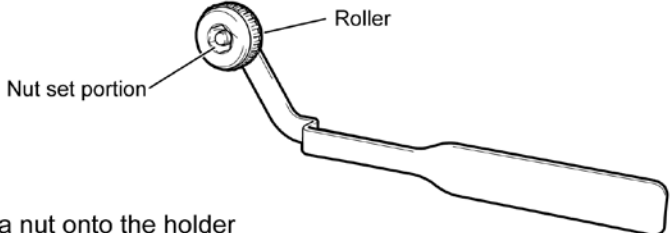

1) Set a nut onto the holder

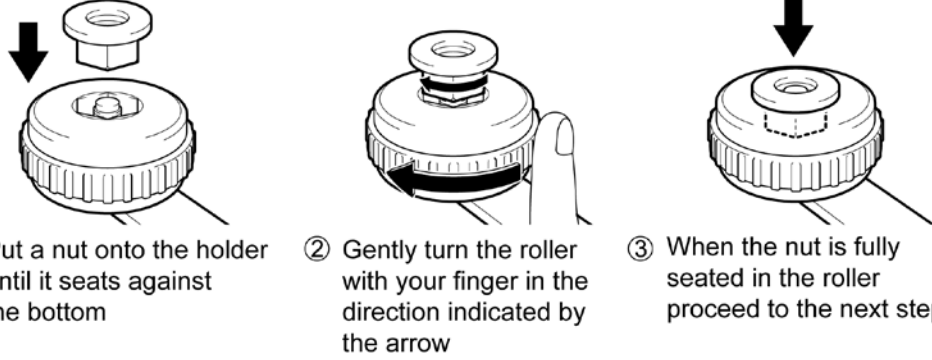

- ① Put a nut onto the holder until it seats against the bottom
- ② Gently turn the roller with your finger in the direction indicated by the arrow
- ③ When the nut is fully seated in the roller proceed to the next step

2) Install a nut

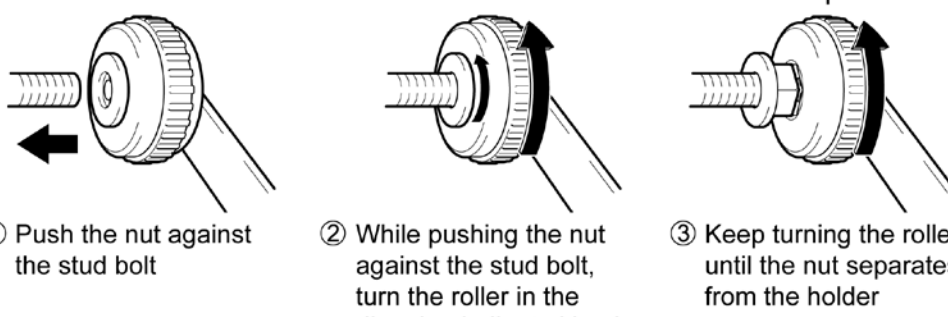

- ① Push the nut against the stud bolt
- ② While pushing the nut against the stud bolt, turn the roller in the direction indicated by the arrow
- ③ Keep turning the roller until the nut separates from the holder

**NOTE:**  
If the holder is set at an angle, the nut may fall. Set the holder perpendicular to the stud bolt.

b) Loosely install the nut towards the front of the vehicle by hand.

c) Use the brake pump wrench (campaign tool) and beam torque wrench (SST 00002-02955) to torque the 2 nuts.

**Torque: 31in. lbf (3.5N·m)**

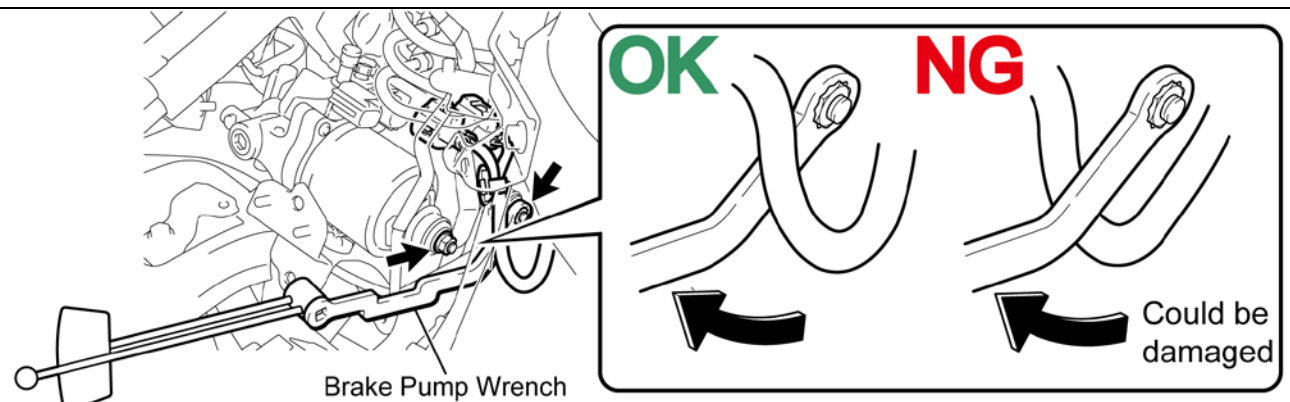

**OK** **NG**

Could be damaged

Brake Pump Wrench

S11703cP

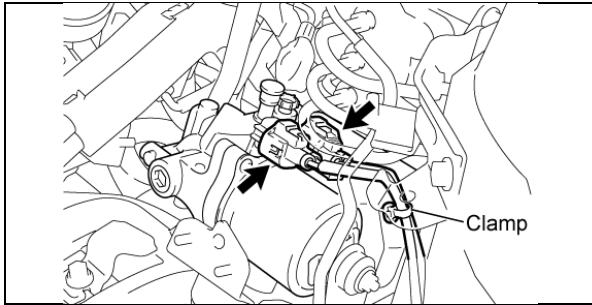

#### 5. CONNECT THE ACCUMULATOR CONNECTORS

- a) Connect the harness clamp and the 2 connectors.

**NOTE: Remove the protective tape from the brake tube.**

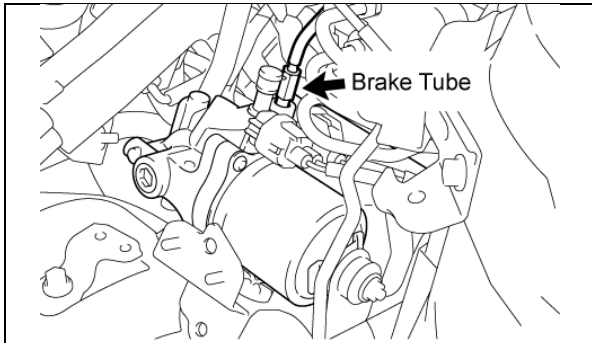

#### 6. REINSTALL THE FRONT No.1 BRAKE TUBE

- a) Remove the plug from the accumulator.
- b) Remove the plastic bag from the brake line.
- c) Insert the brake tube perpendicularly into the pump until it seats.
- d) Hold the brake tube and tighten the flare nut by hand.
- e) Torque the flare nut.

**Torque: 11ft. lbf (15N·m)**

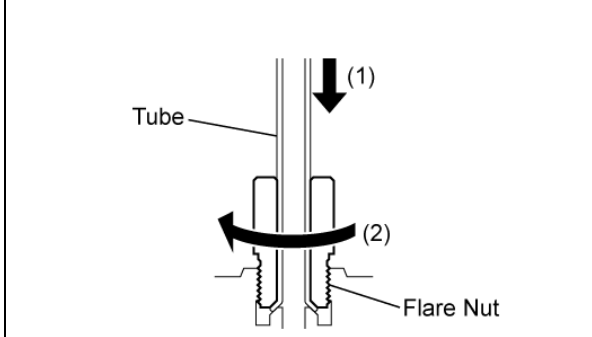

#### 7. SECURE THE BRACKET AND CLAMP

- a) Install the bracket with 1 bolt then install the clamp with 1 bolt.
- b) Use the brake pump wrench (campaign tool) to tighten the bolts.

**Torque: 40in. lbf (4.5N·m)**

**NOTE: Confirm the stopper on the bracket is touching the accumulator.**

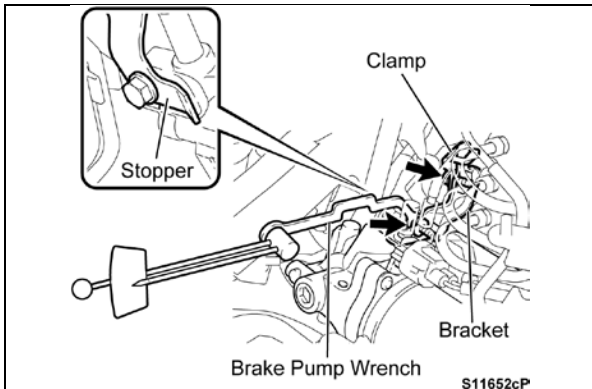

#### 8. RECONNECT THE BRAKE ACTUATOR HOSE

- a) Remove the cap from the accumulator.
- b) Remove the hose plug from the hose.
- c) Connect the hose to the accumulator.
- d) Align the matchmark on the hose with the rib on the accumulator.
- e) Secure the hose with the clip.

**NOTE:**

- Connect the hose immediately after removing the plug in order to prevent brake fluid from leaking.
- Install the clip into its original position.

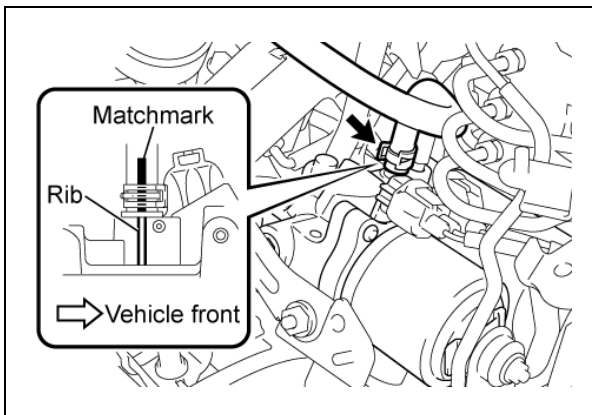

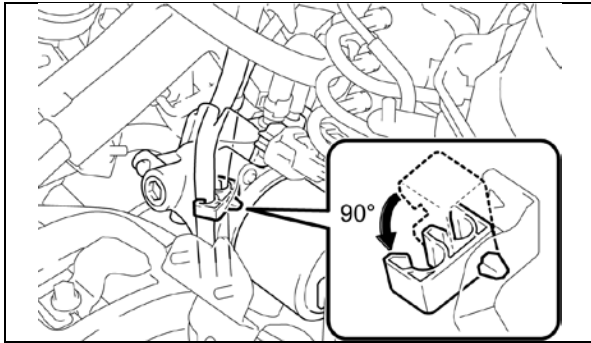

### 9. REINSTALL THE FUEL LINES

- a) Return the clamps to their original horizontal positions and engage the tubes in the clamps.

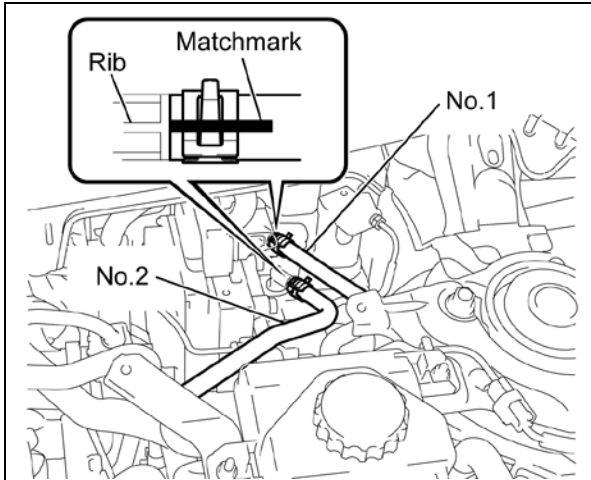

### 10. RECONNECT THE No.1 RESERVOIR TUBE AND No.2 BRAKE MASTER CYLINDER RESERVOIR TUBES

- a) Remove the hose plugs from the hoses.
- b) Connect the hoses to the accumulator.
- c) Align the matchmark on the hoses with the ribs on the accumulator.
- d) Secure the hoses with the clips.

**NOTE:**

- Confirm the hoses are connected in the correct positions on the accumulator.
- Connect the hose immediately after removing the plug in order to prevent brake fluid from leaking.
- Install the clip into its original position.

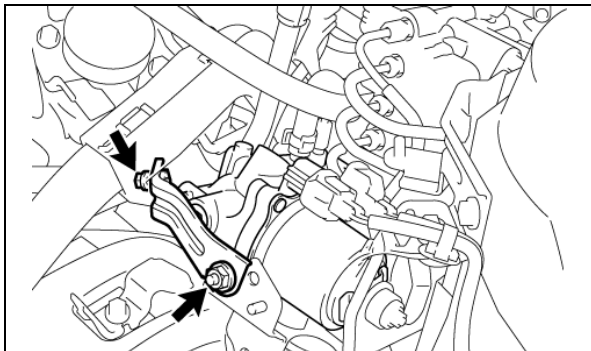

### 11. REINSTALL THE WIRE HARNESS CLAMP BRACKET

- a) Install the bracket with the bolt and nut.

**Torque: 74in. lbf (8.4N·m)**

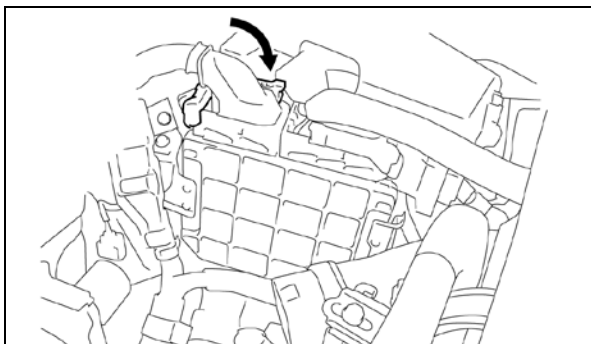

### 12. RECONNECT THE ENGINE HARNESS

- a) Remove the protective tape and bag from the harness and ECU.
- b) Connect and lock the connector.

**NOTE: Confirm the connector is fully secured and locked in place.**

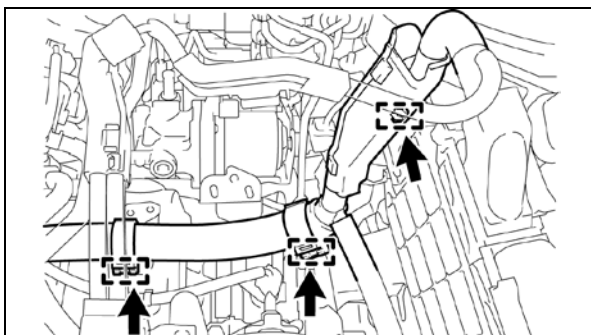

- c) Engage the 3 harness clamps.

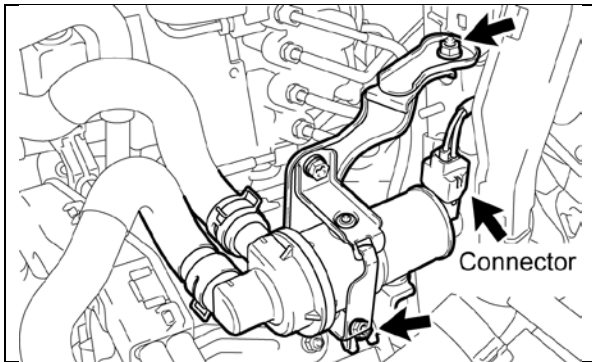

**13. REINSTALL THE HEATER ACCESSORY ASSEMBLY**

- a) Install the heater accessory with the 2 nuts.
- Torque: 87in. lbf (9.8N·m)**
- b) Reconnect the connector.

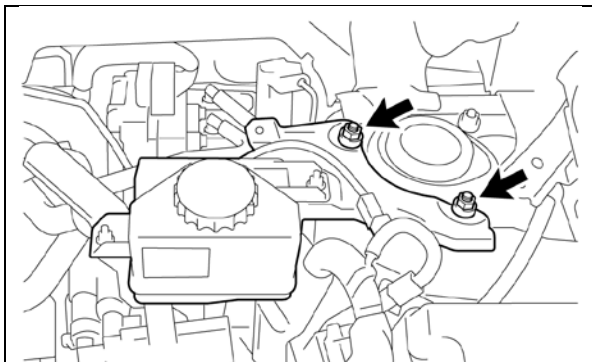

**14. REINSTALL THE BRAKE MASTER CYLINDER RESERVOIR WITH BRACKET**

- a) Install the reservoir with bracket with the 2 nuts.
- Torque: 37ft. lbf (50N·m)**

**15. REINSTALL THE AIR CLEANER CASE**

- a) Refer to [TIS](#) for installation instructions.

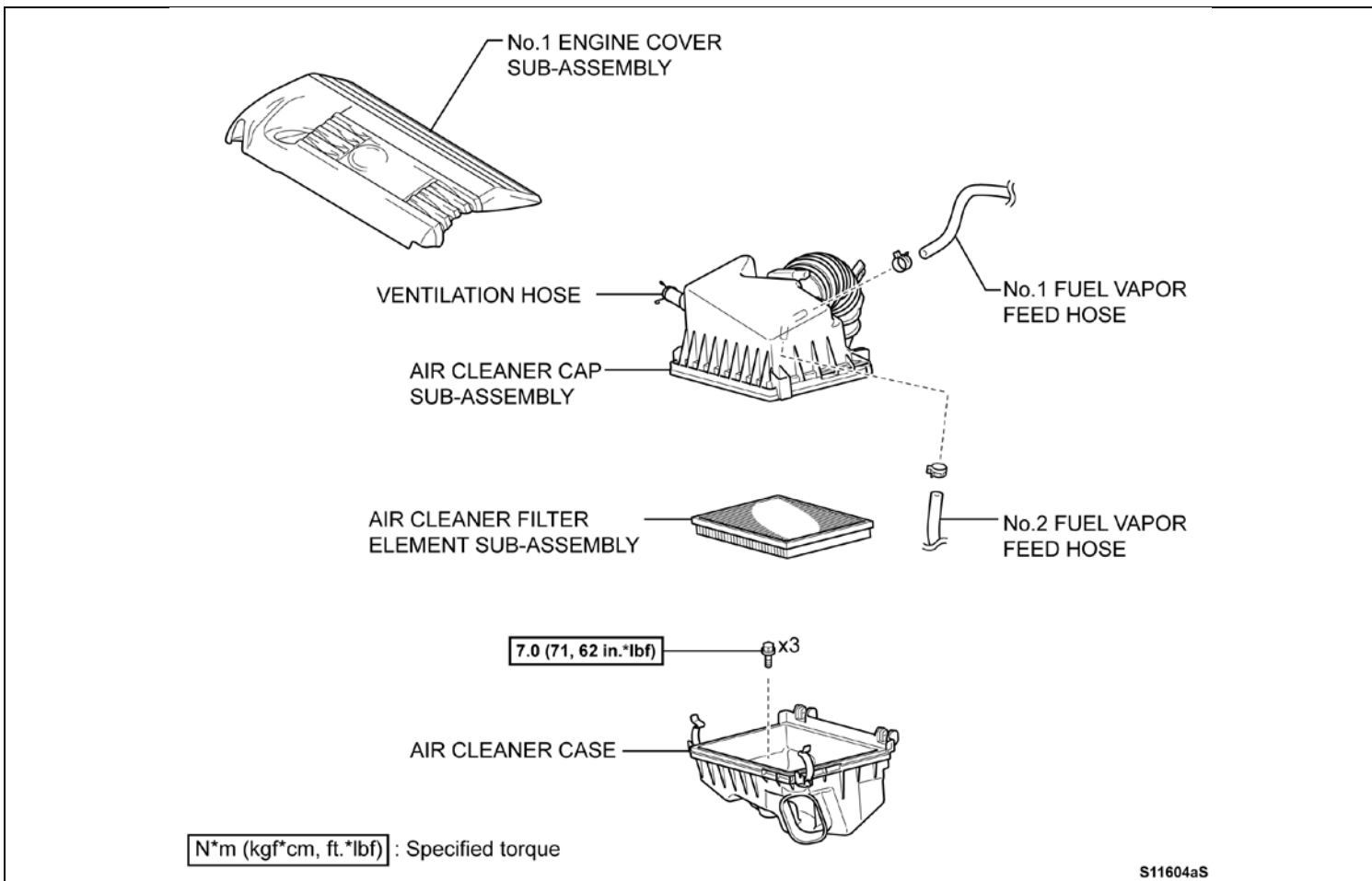

S11604aS



## XI. BRAKE SYSTEM BLEEDING PRECAUTIONS



### CRITICAL INFORMATION – READ THOROUGHLY



These cautions should be observed when bleeding the brake system. Failure to follow these cautions could result in damaged parts or inadequate repair quality.

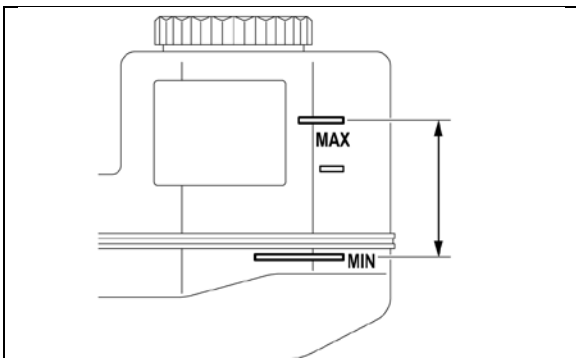

#### 1. FLUID LEVEL

- a) To prevent air entering the brake system, **ALWAYS** maintain the fluid level between the MIN and MAX lines.

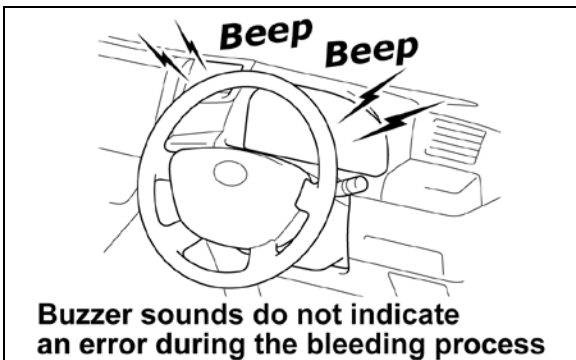

#### 2. WARNING BUZZER

- a) A buzzer may sound during the bleed procedure indicating a pressure decrease, this is normal.

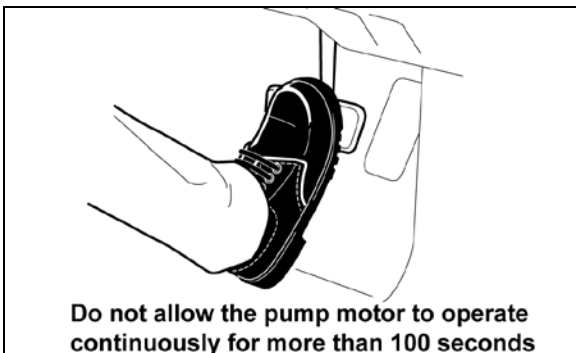

#### 3. PUMP MOTOR

- a) To avoid potential damage to the pump motor, **DO NOT** allow the motor to operate continuously for more than 100 seconds. To stop the motor from operating, release the brake pedal.



#### 4. DTCs

- a) It is normal for DTCs to be set when bleeding the system. DTCs should be cleared when instructed to do so.

## XII. BRAKE SYSTEM BLEEDING

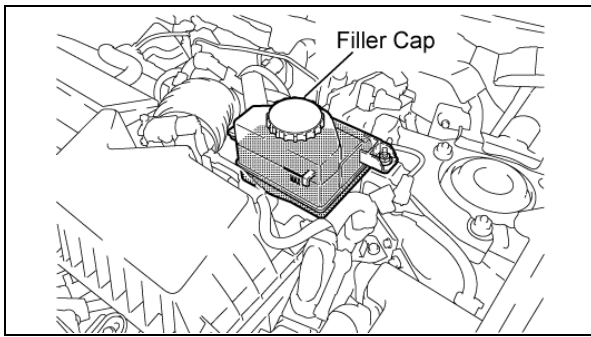

1. RAISE THE VEHICLE AND REMOVE THE WHEELS
2. FILL THE RESERVOIR WITH BRAKE FLUID
  - a) Fill the reservoir between the MIN and MAX indicators.

### 3. RECONNECT THE BATTERY

**NOTE:** READY ON may remain inactive after reconnecting the battery. If this happens, open and close the driver door once with IG OFF to reset the system.

### 4. BLEED THE BRAKE SYSTEM

- a) Connect a battery charger.
- b) Connect Techstream.
- c) Enter the ABS/VSC/TRAC ECU.
- d) Click on 'Utility' and select 'Air Bleeding'
- e) Select 'ABS actuator has been replaced'.



- Carefully read and follow the instructions on the Techstream while bleeding the system. If the instructions are not followed or a mistake is made, start the procedure over again.
- If the accumulator is operated when the reservoir is empty, the accumulator could be damaged. Confirm the fluid level is always between the MIN and MAX indicators.
- If the bleed procedure will not complete successfully after several attempts, it may be necessary to replace the brake booster assembly.

- f) After bleeding is complete, tighten each bleeder plug to the specified torque.
- g) Disconnect the battery charger.
- h) Confirm there is no brake fluid leakage.
- i) Install the wheels.

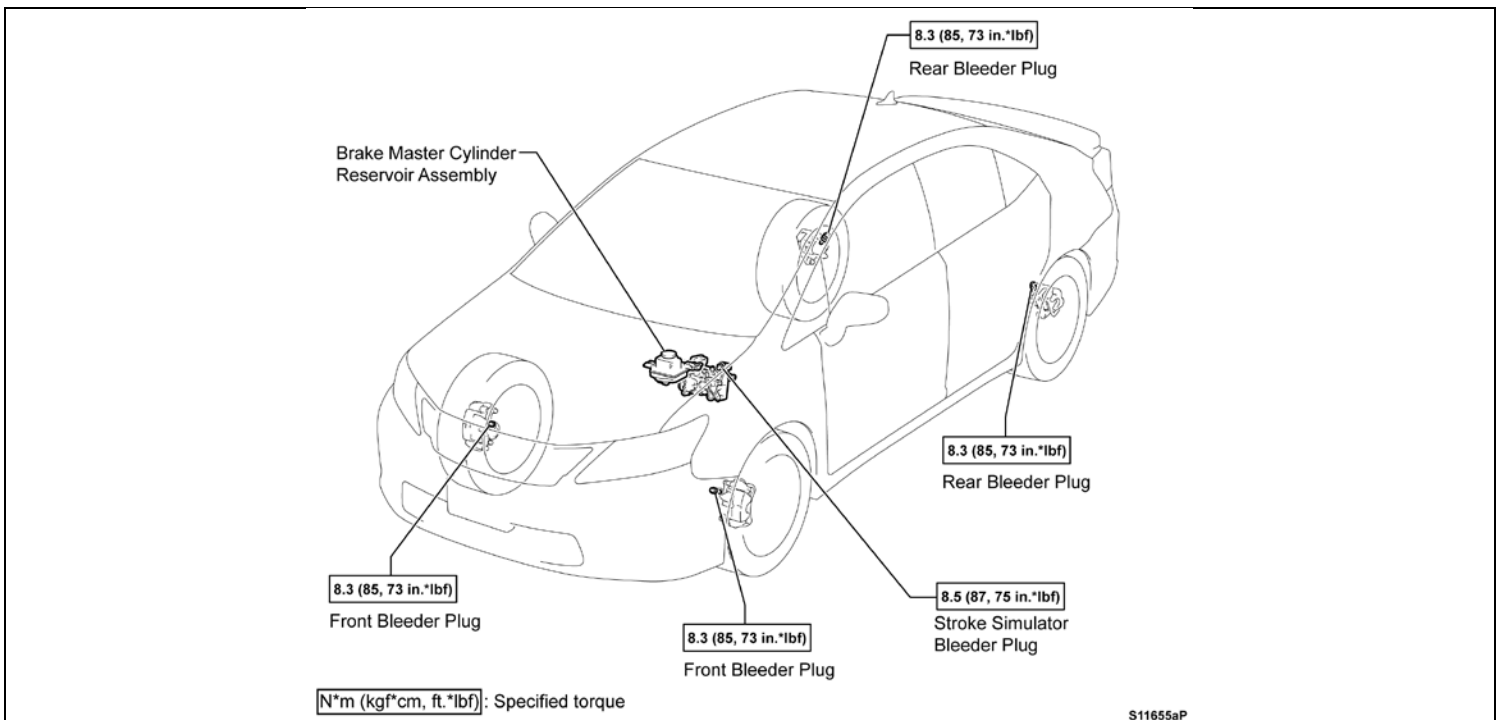

### XIII. FINAL VEHICLE ASSEMBLY

#### 1. REINSTALL THE OUTER COWL TOP PANEL SUB-ASSEMBLY

- a) Refer to [TIS](#) for installation instructions.

#### 2. CHECK AND CLEAR DTCs



If DTC C1345 'Linear Solenoid Valve Offset Learning Undone' is found after the bleeding procedure, the bleed procedure was not completed correctly. Conduct the 'Linear Solenoid Valve Offset Learning' by referring to TIS: Brake / Electronically Controlled Brake System: Initialization. If you continue to have difficulties, contact TAS.

#### 3. PERFORM ISC INITIALIZATION



If the ISC initialization is skipped, a rattle sound may be emitted from the transaxle.



- a) Connect Techstream.
- b) Enter the Hybrid Control ECU.
- c) Click on 'Utility' and select 'Inspection Mode'
- d) Select '2WD for Measuring Exhaust Gas'
- e) Confirm 'Maintenance Mode' is displayed on the instrument cluster, then READY ON the vehicle.

Parameter	Value	Unit
Coolant Temp	170	F
ISC Learning	compl	

- f) Enter the Engine and ECT ECU and go to the data list.
- g) Warm up the engine until the coolant temperature exceeds 158°F (70°C).
- h) Turn IG OFF and then back to READY ON.
- i) Start the engine by depressing the accelerator pedal.
- j) Wait until the engine stops, then confirm the ISC Learning reads 'Compl'.

**NOTE:** The engine normally automatically stops within 1 minute; however, if the battery charge is low it may take longer.

#### 4. TEST DRIVE THE VEHICLE

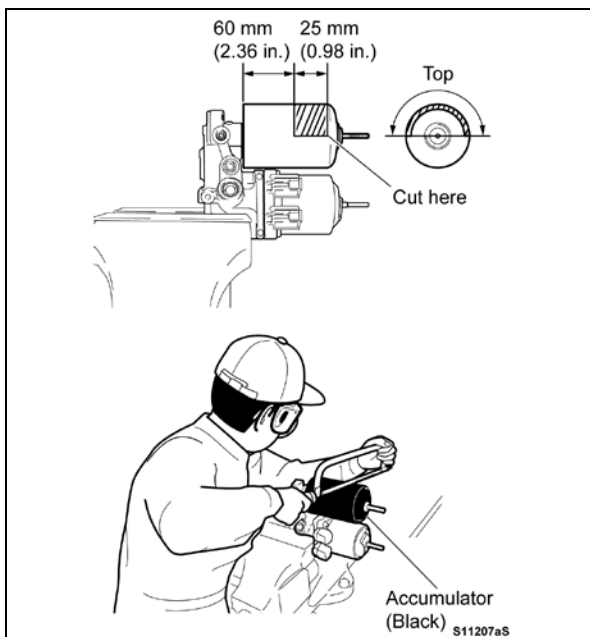

#### 5. DISPOSE OF OLD ACCUMULATOR

- a) Clamp the accumulator in a vise.
- b) Use a hacksaw to make a relief cut in the black accumulator cylinder in the area highlighted in the illustration.

**NOTE:** The enclosed nitrogen gas is colorless, odorless, and non-toxic.



- **ALWAYS** wear protective glasses.
- **Cut the accumulator slowly.**
- **DO NOT** use power tools.

## ◀ VERIFY REPAIR QUALITY ▶

- Confirm the accumulator label and DTC inspection is followed exactly as described
- Confirm the brake pressure is released before disconnecting any brake lines
- Confirm brake bleeding and ISC initialization are completed correctly

If you have any questions regarding this update, please contact your area representative.

### XIV. APPENDIX

#### A. CAMPAIGN DESIGNATION DECODER

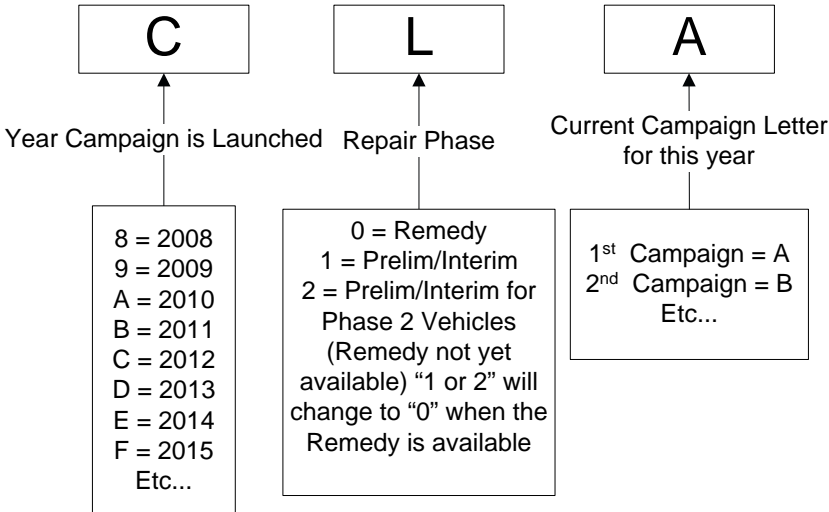

#### B. CAMPAIGN PARTS DISPOSAL

As required by Federal Regulations, please make sure all campaign parts (original parts) removed from the vehicle are disposed of in a manner in which they will not be reused, ***unless requested for parts recovery return.***