

ATTENTION:

- GENERAL MANAGER
- PARTS MANAGER
- CLAIMS PERSONNEL
- SERVICE MANAGER

IMPORTANT - All Service Personnel Should Read and Initial in the boxes provided, right.



QUALITY DRIVEN® SERVICE

PRODUCT CAMPAIGN BULLETIN

APPLICABILITY: 2010 and 2011MY Subaru Legacy and Outback 2006 through 2012MY Tribeca vehicles sold before January 2012
 2009 through 2012MY Forester vehicles sold before January 2012

NUMBER: WQE-41
DATE: February 2013

SUBJECT: Optional Genuine Subaru Puddle Lights

Subaru has determined that affected vehicles equipped with optional Genuine Subaru Puddle Lights may develop a short circuit and cause the related components to overheat and potentially melt.

A short circuit can develop when either the puddle lights or connectors are exposed to an electrolytic moisture source (i.e.- salt water) and it penetrates the circuit board of the puddle light or the pins of the puddle light connector(s). If the puddle lights or connectors were to overheat, they could melt and pose a risk of a fire.

This recall will involve vehicle inspection and installation of inline fuses as necessary.

AFFECTED VEHICLES

The following vehicles equipped with puddle lights are affected:

- **2010 and 2011MY Subaru Legacy and Outback**
- **2006 through 2012MY Tribeca vehicles sold before January 2012**
- **2009 through 2012MY Forester vehicles sold before January 2012**

Of the puddle light kits produced that could experience this condition, approximately 93% were installed by a port facility prior to delivery to dealers. The remaining 7% kits were either installed by dealers or sold to individuals in kit form.

- **Vehicles with Port Installed Puddle Lights**
 Vehicles equipped with port installed puddle lights have been identified and will appear in vehicle coverage inquiry with the campaign code WQE-41.
- **All Other Potentially Affected Vehicles**
 Vehicles within the affected group that do not have port installed puddle lights will appear in vehicle coverage inquiry with the campaign code WQE-99. For any vehicle in this category that has puddle lights, it will be necessary to contact the Subaru Claims Helpline at 1-866-782-2782 in order to have the VIN added to the recall.

OWNER NOTIFICATION

There are two versions of owner notification letters.

Version 1 addresses vehicle owners who are known to have a vehicle equipped with port installed puddle lights. The letter will inform the owner that their vehicle is affected by this recall. Vehicles in this category will appear in vehicle coverage inquiry with the campaign code WQE-41.

Continued...

Version 2 addresses all other vehicle owners who have a vehicle that may have had puddle lights installed after the vehicle was first delivered to a dealer. The letter will inform the owner that their vehicle is affected by this recall if it is equipped with puddle lights. Vehicles in this category will appear in vehicle coverage inquiry with the campaign code WQE-99.

A copy of both owner notification letters is included at the end of this bulletin.

In addition to notification by mail, vehicle owners with a valid email address and MySubaru subscribers will be notified electronically on the same date letters are mailed.

Owner notification letters began mailing on February 19, 2013.

DEALER PROGRAM RESPONSIBILITY

Dealers are to promptly perform the applicable service procedures defined in this bulletin to correct all affected vehicles in their inventory (new, used, demo & SSLP). Additionally, whenever a vehicle subject to this recall is taken into dealer new or used inventory, or in the dealership for service, necessary steps should be taken to ensure the recall correction has been made before selling or releasing the vehicle.

New, used, demo or SSLP vehicles listed in a recall/campaign that are in dealer stock must be:

- Immediately identified.
- Tagged or otherwise marked to prevent their delivery or use prior to inspection and/or repair.
- Repaired in accordance with the repair procedures outlined in this Product Campaign Bulletin.

Please be advised that it is a violation of Federal law for a dealer to deliver a new motor vehicle covered by a recall under a sale or lease until the defect is remedied. Therefore, any Authorized Subaru Dealer failing to perform the applicable service procedures as defined in this bulletin to correct all affected vehicles in their inventory (new, used, demo & SSLP) prior to the vehicle being placed in service may be subject to civil penalties of up to \$6,000 per violation (i.e., for each vehicle), as provided in 49 CFR §578.6 and will also be in breach of the Subaru Dealer Agreement.

PARTS INFORMATION

Repair parts are currently available. It is suggested that parts be ordered at the time a customer contacts a dealer to schedule an appointment. This will ensure the necessary parts are available on the day a customer brings their vehicle in for service.

Part Number	Description
H001SSC300	Fused Mini-Harness (2 required per vehicle)

Continued...

SERVICE PROCEDURE

The goal of this procedure is to ensure the vehicle has an in-line fuse installed in series with the puddle light harness on both sides of the vehicle and that the puddle light system operates as designed. This inspection / repair procedure will be accomplished by accessing the puddle light harness to body harness connection. This is achieved with removal of the front accessory splash guard/ mud flap (if equipped) and a partial removal of the fender's inner splash shield/ fender liner for each front wheel. Regardless of the findings of the inspection of one side, both sides must be inspected/ repaired to complete this campaign.

NOTES:

- See **Appendix C** for a summary flow chart of the following procedure. Be sure to follow the detailed written procedure below in its entirety. The flow chart only provides a summary. In addition, a Post-Repair Diagnosis flow chart is provided for reference if needed.
 - Read through and understand this complete procedure before beginning any repairs.
1. **Confirm the vehicle is equipped with optional Genuine Subaru puddle lights.** If the vehicle is not equipped, no correction is required. Return the vehicle to the Customer.



CHECK FOR FUNCTIONING PUDDLE LIGHTS

If the vehicle **IS** equipped with Genuine Subaru puddle lights:

2. Verify the operation of all 4 puddle lights (2 lights per side, 2 LED bulbs per light). The lights may be activated by opening the driver's door. Inspect both sides at this time.
3. Complete the next steps starting with the driver's side of the vehicle and then repeat on the passenger side. Both sides must be completed for this campaign. All current replacement puddle light harnesses include an in-line mini fuse.

NOTE: If any puddle lights are found inoperative, whether there is an in-line fuse installed or not, replace the puddle light harness and both light assemblies on that side of the vehicle. Refer to the Accessory Installation Guide available on STIS for specific accessory component installation procedures. Search STIS using the keyword "puddle". Not all model years and models are shown, so refer to the instructions for the model year and model you are working on. If your model year is not shown, use the next latest model year.

Continued...

4. If both puddle lights were operational on each side, determine if the puddle light harnesses on both sides are fitted with in-line fuses (detailed instructions are provided in **Appendix A**).

NOTE: The in-line fuse may be either part of the existing harness itself, or a separately fused mini-harness.

5. If an in-line fuse is verified in the puddle light harnesses on both sides of the vehicle, and the lights function normally, no further action is necessary. Re-assemble the splash shields and return the vehicle to the customer completing the campaign procedure.
6. If there is no in-line fuse present on either side puddle light harness, a fused mini-harness must be installed. Record the customer's radio station presets (and navigation Favorites) then disconnect vehicle battery before installing the Fused Mini- Harness.

NOTE: If there is any corrosion or damage to the puddle light harness side connection, replace the harness and both lights. If there is any corrosion or damage to the body harness side where the puddle light harness connects, repair or replace the body harness as necessary.

7. Once both sides have had in-line fuses either installed or verified, reconnect the battery and confirm that the puddle lights are operational. Leave the driver's door open with the puddle lights on for at least 5 minutes before reinstalling the splash shields. If the lights do not operate, and the in-line fuse becomes open, replace the harness and both light assemblies on the affected side of the vehicle.

Appendix A - Harness Access and Inspection Process

1. Raise the vehicle as necessary to access the inner fender splash shields. Wheel removal is generally not required.
2. Remove the accessory splash guard (if equipped) and the retaining clips at the rear portion of the front wheel opening. Move just enough of the splash shield to expose the puddle light wiring and body harness connectors



Continued...

NOTES:

- A Forester is shown in the photo on pg. 4 for illustration only.
- Splash guard removal may also be required for access to the splash shield retaining clips.
- Retaining clip locations will vary by model.
- See **Appendix B** for samples of retaining clip locations by model.
- The photos below show a puddle light harness **without** the in-line fuse on the left and the current replacement harness **with** the in-line fuse on the right.



No in-line fuse installed



With in-line fuse installed

CAUTION:

On Legacy, Outback and Forester models, locate the two metal tabs along the inside edge of the front fender. Use caution and support these small painted fender tabs inside the wheel arch when removing the splash shield. These tabs are painted body color and cracking of the paint is likely if the tabs are bent. Place one hand on the tab to secure it while pushing the splash shield up and over the tab with your other hand. Use the same method when you reinstall the splash shield. Touch-up any damaged tabs to minimize any future possibility of rust.



Continued...

- On Legacy and Outback models, use caution when moving the splash shield as the body harness for the puddle lights is secured to it at two points as shown below. It is not required to drop the entire splash shield. Simply move enough of the shield to gain access to the connection which is located at the rear of the wheel opening. This information and photo are provided as a reference only.

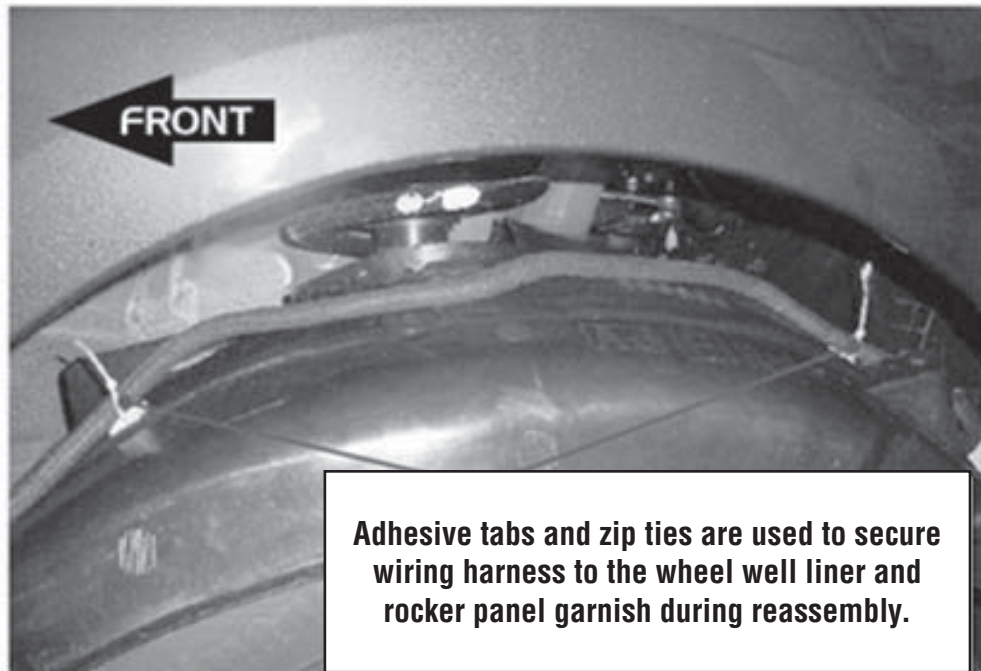

3. Once the splash shield has been moved enough for access, inspect the puddle light harnesses.
 - a. If the vehicle already has an in-line fuse in the red power wire within a few inches of the vehicle connector as shown in the photo below or a Fused Mini-Harness as shown in the photo on pg. 7 and both lights (all 4 LED bulbs) operate, no further action is required on that side.

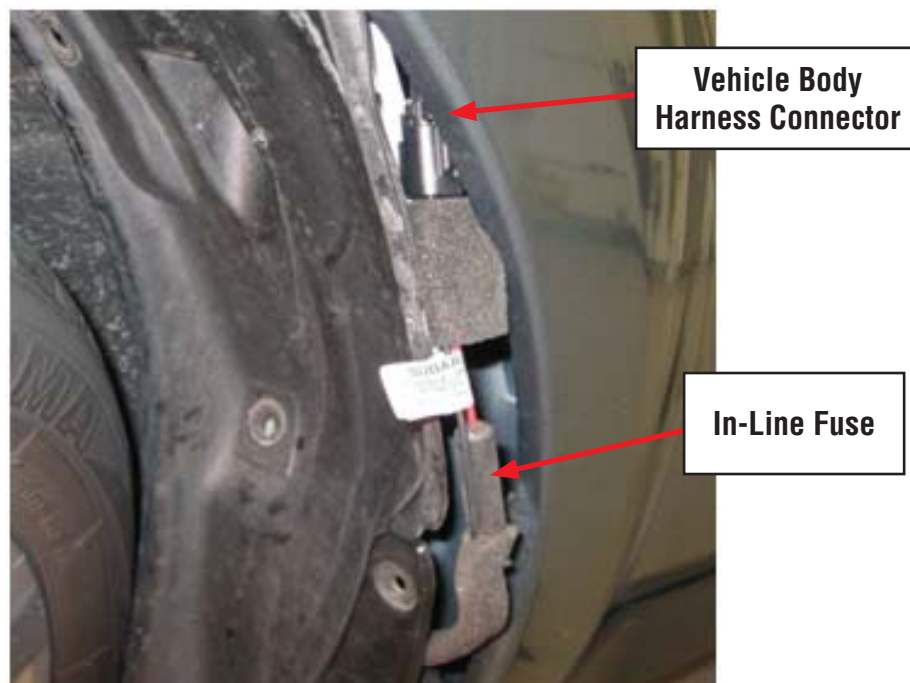

Continued...

- b. Next, check the other side of the vehicle starting again at Step 2. Once inspection of both sides of the vehicle is complete and fuses are confirmed to be on **BOTH** sides of the vehicle, proceed to Step 5, otherwise see “c” below.
- c. If no in-line fuse or Fused Mini-Harness is present, unplug the puddle light harness connector from the vehicle body harness connector and install the Fused Mini-Harness as shown in the reference photos below.

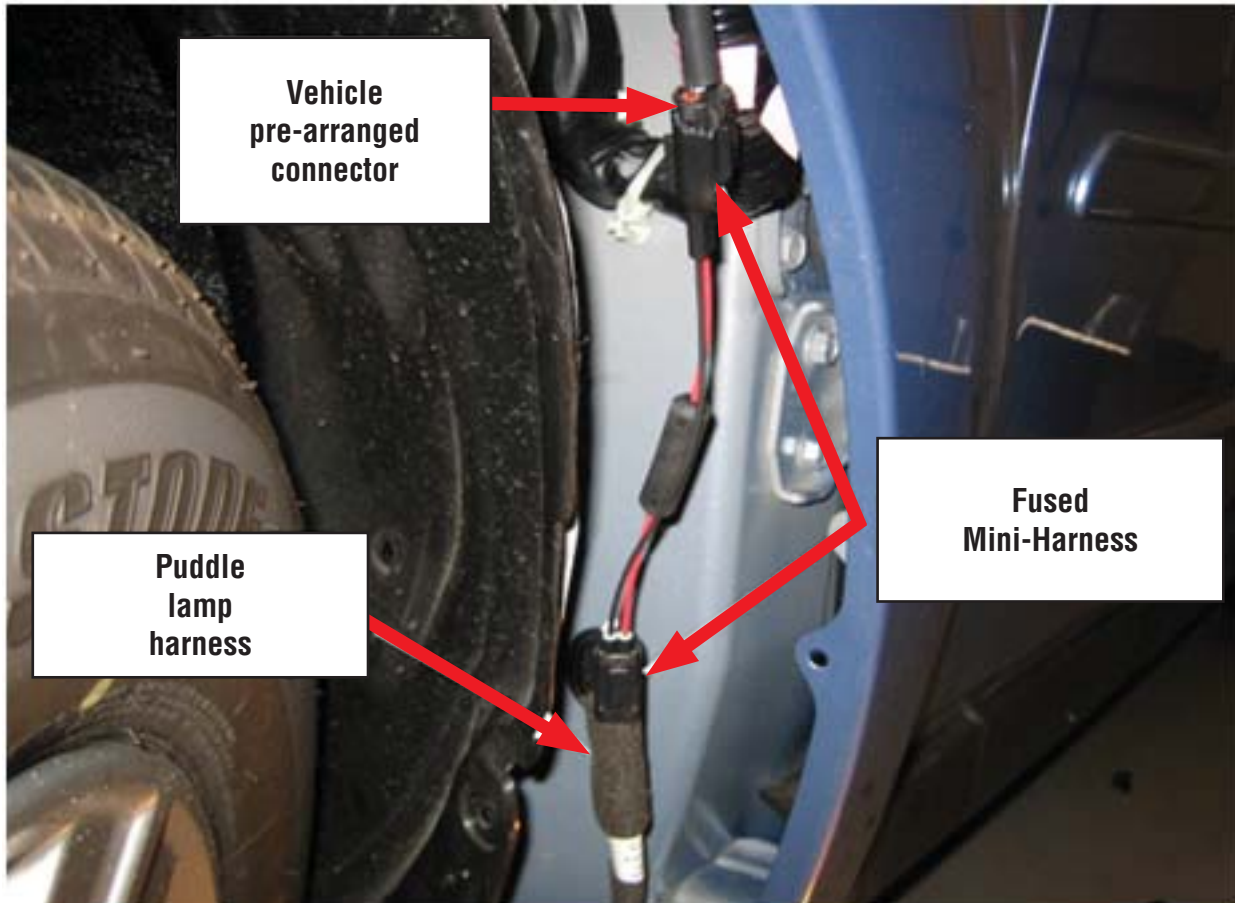

Fused Mini-Harness

Route the completed harness behind the splash shield. Use electrical tape to secure any excess harness out of the way avoiding any areas where it may be exposed to sharp edges or become pinched. **Do not reassemble yet.** Once both sides of the vehicle have been completed, proceed to the next step.

Continued...

4. After completing installation of the Fused Mini-Harness on both sides of the vehicle, reconnect the battery and confirm that all the puddle lights operate normally by leaving the driver's door open with the puddle lights on for at least 5 minutes.
 - a. If any of the lights fail to operate as designed, review all connections to ensure they are secure.
 - b. If the mini-fuse in the Fused Mini-Harness or puddle light harness has become open, replace the puddle light harness and both lights on that side of the vehicle. Refer to applicable accessory installation guide for detailed instructions for harness and light installation. **NOTE:** All current replacement puddle light harnesses include an in-line fuse. In this case, installation of the Fused Mini-Harness would not be required.
 - c. If not resolved, by a and / or b, see the Post-Repair Diagnostic Flow Chart in **Appendix C**.

IMPORTANT: At no time should two mini fuses be placed in series on the same side/ same circuit.

5. Once proper operation is confirmed, reinstall the splash shields, retaining clips and splash guards (if equipped).
6. Perform one final check to confirm all 4 puddle lights operate properly to complete the procedure before releasing the vehicle.

NOTE: If additional parts are necessary to repair the vehicle, a listing by model is supplied below

2010-2012 Legacy and Outback Models

- H471SAJ010 LED Lamp Assy. (2 per side)
- H471SAJ020 Puddle Light Harness (1 per side)
- H471SAJ030 Hardware Kit (1 per vehicle)

2006-2012 Tribeca Models

- H471SXA010 LED Lamp Assy. (2 per side)
- H471SXA020 Hardware Cap (2 per lamp)
- H471SXA030 Puddle Light Harness (1 per side)
- H471SXA040 Hardware Kit (1 per vehicle)

2009-2012 Forester Models

- H471SSC010 LED Lamp Assy. (2 per side)
- H471SSC020 Puddle Light Harness (1 per side)
- H471SSC030 Hardware Kit (1 per vehicle)

Continued...

Appendix B - Retaining Clip Locations

Reminder: Splash guard /mud flap removal may also be required in some cases to access the retaining clips. Splash guards vary by model, but most involve removal of one horizontal clip, two horizontal screws, and one vertical screw. **Tip:** When reinstalling splash guards install the screws loosely and lift up lightly on the splash guard while giving the screws a final tightening. This will help reduce the possibility of a gap forming between the splash guard and the fender.

2006-2007 B9 Tribeca (5 clips)

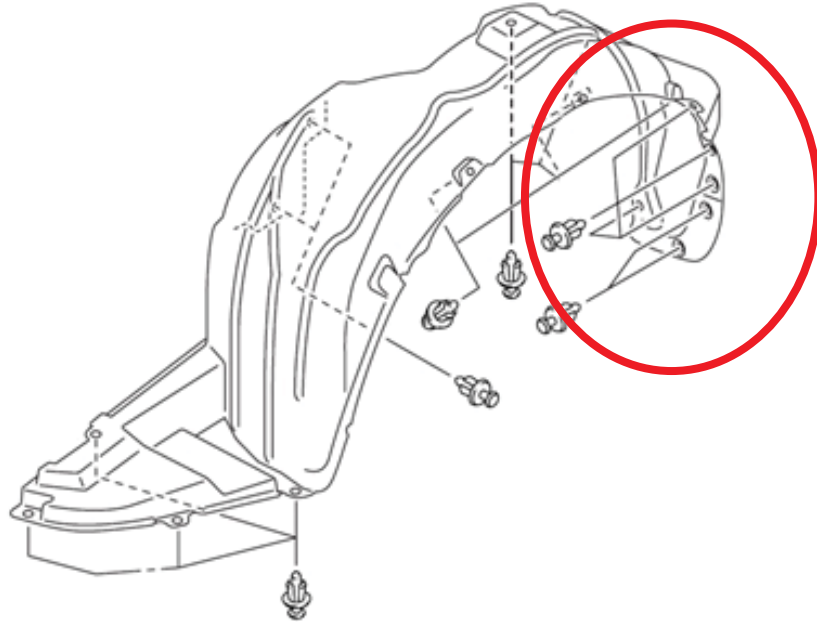

2008-2012 Tribeca (5 clips)

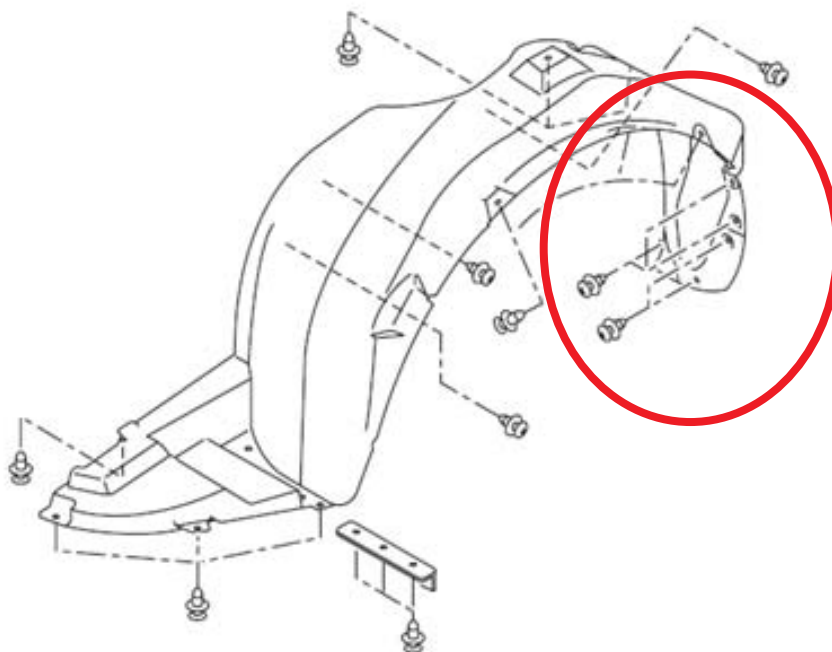

Continued...

2010-2011 Legacy and Outback (8 screw clips and 1 push clip)

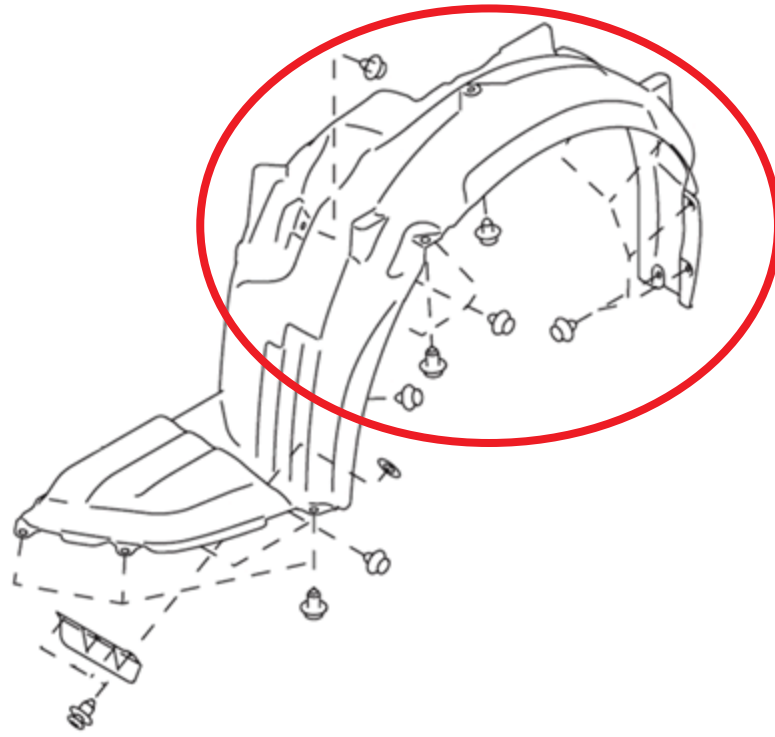

2009-2012 Forester (3 clips)

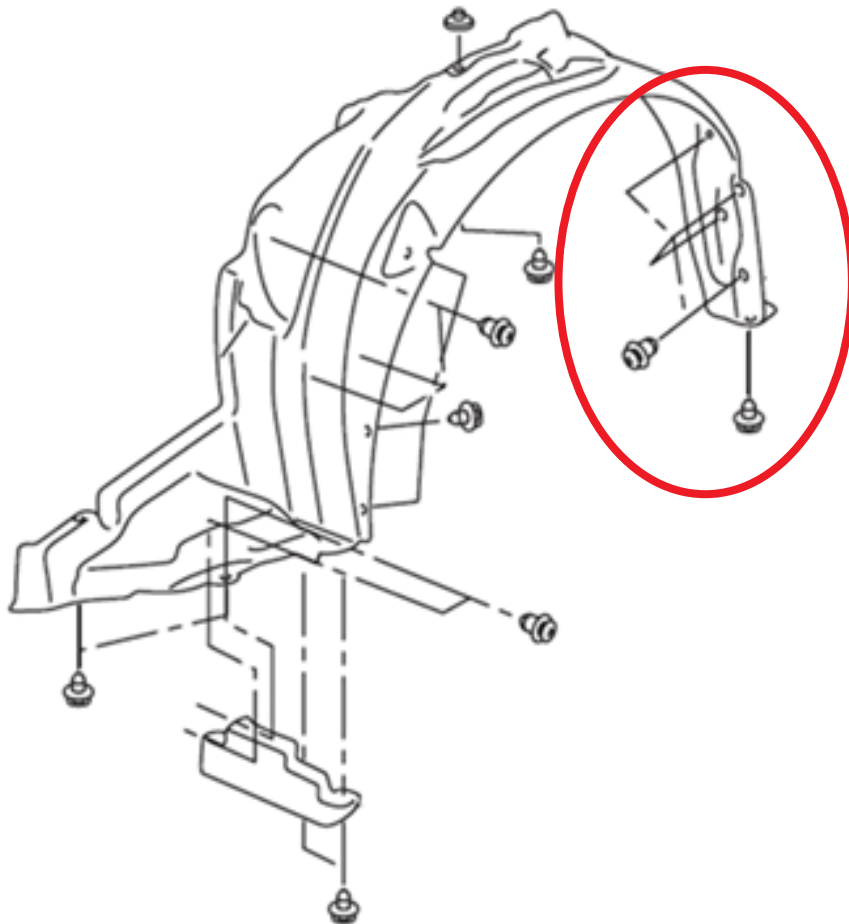

Continued...

Appendix C - Summary and Post-Repair Flow Charts

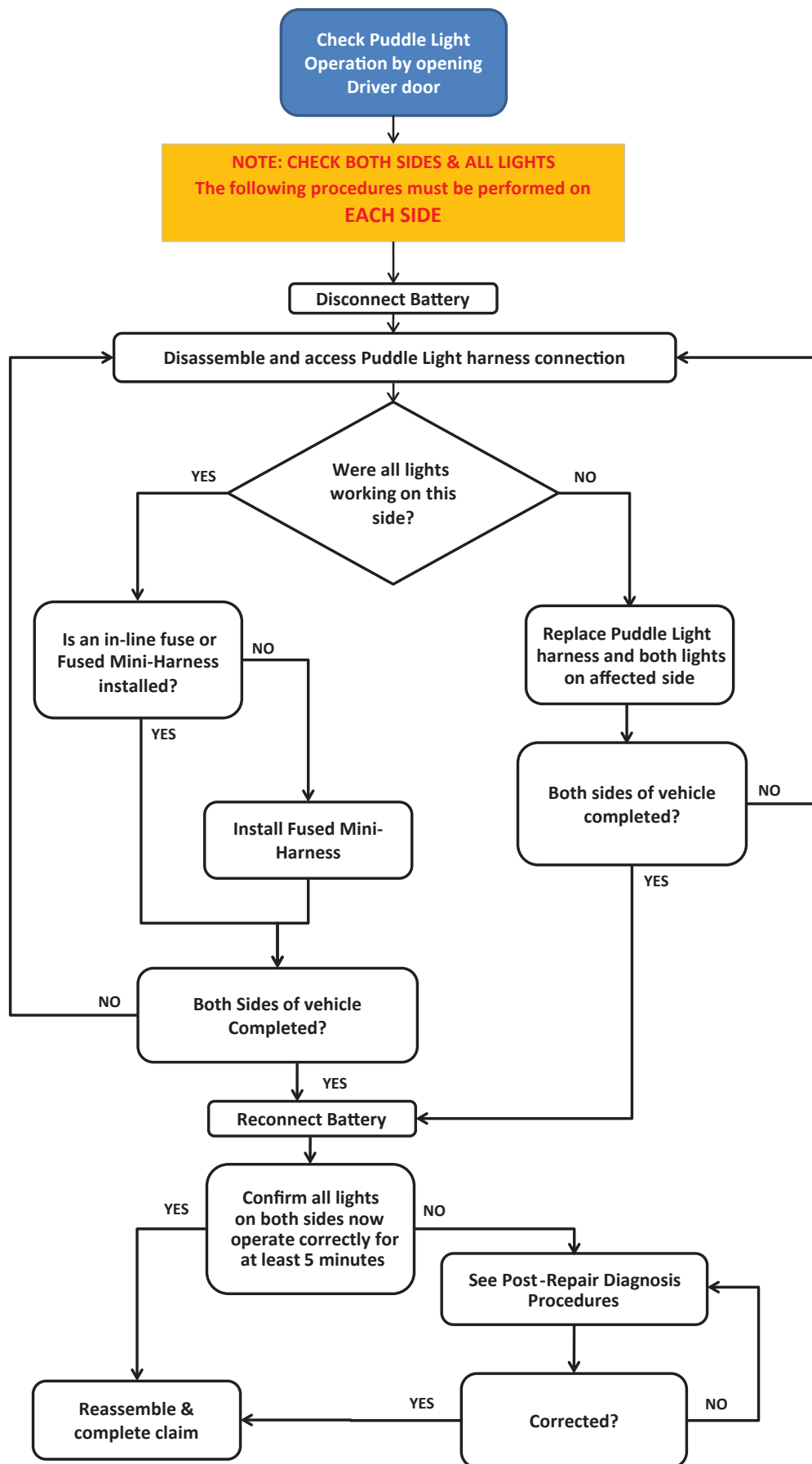

Continued...

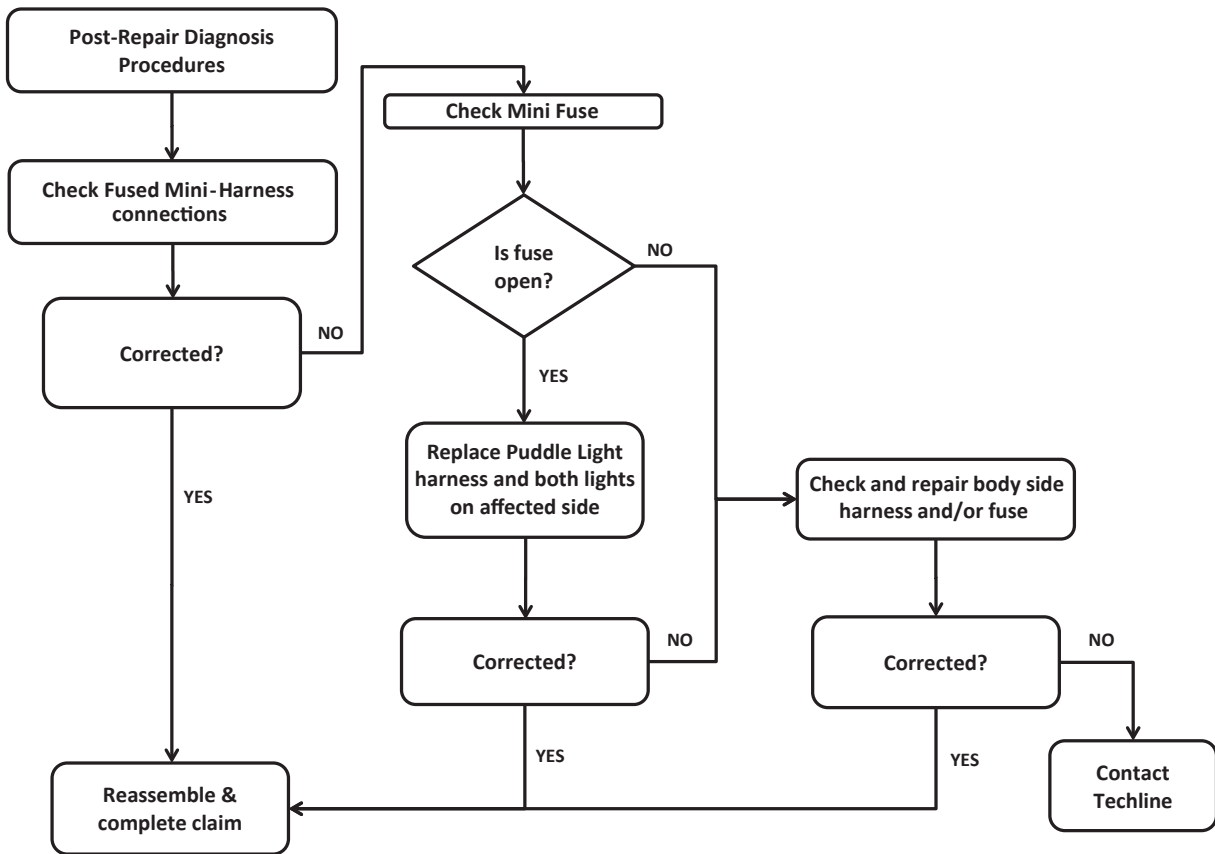

SERVICE PROGRAM IDENTIFICATION LABEL

Type or print the necessary information on a Recall Campaign identification label. The completed label should be attached to the vehicle's upper radiator support.

Additional labels are available by calling the Subaru Claims Helpline at: 1-866-782-2782.

SUBARU
Campaign Code
WQE-41
COMPLETED
DIST./DEALER NO.
SERIAL NO.
DO NOT REMOVE

Continued...

CLAIM REIMBURSEMENT AND ENTRY PROCEDURES

Credit to perform this service program will be based on the submission of properly completed repair order information. Dealers may submit claims through Vehicle Claim Entry on Subarunet.com.

LABOR DESCRIPTION	LABOR OPERATION #	FAIL CODE	LABOR TIME
Vehicle Inspection for WQE-41, BOTH SIDES	A115-908	WQE-41	0.4
Inspection BOTH SIDES with Installation of Fused Mini-Harness- ONE SIDE	A115-921		0.5
Inspection BOTH SIDES with Installation of Fused Mini-Harness- BOTH SIDES	A115-904		0.5
Inspection BOTH SIDES with Puddle Light and Harnessess R&R- ONE SIDE	A115-911		0.7
Inspection BOTH SIDES with Puddle Light and Harnessess R&R- BOTH SIDES	A115-914		0.9
Inspection BOTH SIDES, Install Fused Mini-Harness ONE SIDE and both Puddle Lights and Harness OPPOSITE SIDE	A115-923		0.7

Continued...

**OWNER NOTIFICATION LETTER
VERSION 1**



Subaru of America, Inc
Subaru Plaza
PO Box 6000
Cherry Hill, NJ 08034-6000
800-782-2783
www.subaru.com

**Important Safety Recall Notice
Subaru Recall Campaign WQE41-1
NHTSA Recall No. 12V-602
February 2013**

Dear Subaru Owner:

This notice is sent to you in accordance with the requirements of the National Traffic and Motor Vehicle Safety Act. SUBARU OF AMERICA, INC. has decided that a defect, which relates to motor vehicle safety, exists in some 2006 through 2012 model year Subaru vehicles equipped with optional Genuine Subaru Puddle Lights.

DESCRIPTION OF THE SAFETY DEFECT

Subaru has determined that your vehicle has been equipped with optional left and right side puddle lights that may develop a short circuit and cause the related components to overheat and potentially melt.

A short circuit can develop when either the puddle lights or connectors are exposed to an electrolytic moisture source (i.e.- salt water) and it penetrates the circuit board of the puddle light or the pins of the puddle light connector(s).

DESCRIPTION OF THE SAFETY HAZARD

Puddle lights are mounted in your vehicle's left and right rocker panel trim and automatically illuminate the ground in the area near the doors when you enter and exit the vehicle. If the puddle lights or connectors were to overheat, they could melt and pose a risk of a fire.

REPAIRS

To correct this condition, Subaru will inspect and if necessary repair the puddle lights. If in-line fuses for both the left and right side puddle lights are not already installed, they will be added as a precautionary measure at no cost to you.

WHAT YOU SHOULD DO

You should immediately contact your Subaru Dealer for an appointment to have this repair performed at no cost to you.

There are several important precautions you should take until this repair has been performed:

- If you notice or smell smoke in the left or right rocker panel area of the vehicle, be sure the ignition switch is in the "off" position and do not operate the vehicle. Immediately contact your Subaru dealer for assistance.
- As a precautionary measure, it is highly recommended that you not park your vehicle in a garage, car port or other structure.

HOW LONG WILL THE REPAIR TAKE?

The actual time to inspect your vehicle and, if necessary, install in-line fuses is approximately 30 minutes. Any other repairs could take up to an additional 25 minutes. However, it may be necessary to leave your vehicle for a longer period of time on the day of your scheduled appointment to allow your dealer flexibility in scheduling. Please present this letter to your Subaru Dealer at the time this repair procedure is performed.

IF YOU HAVE PREVIOUSLY PAID FOR A REPAIR

If you have already paid for repairs associated with this condition, you may be eligible for reimbursement. Reimbursement consideration will be based on the amount an authorized Subaru dealer in your area would charge for performing those repairs.

Continued...

Please send the original service repair order, which has the name of the repair facility, date of repair, mileage at the time of repair, complete vehicle identification number (17 digits), and your name, with correct mailing address and telephone number to the address listed below.

**Subaru of America, Inc.
Customer Dealer Services Department
Attention: WQE-41 Recall
P.O. Box 6000
Cherry Hill, NJ 08034-6000**

Please send original receipts only and retain a photocopy for your records. Please be assured that we will attempt to process your reimbursement request as quickly as possible, but it may take up to 60 days for this process to be completed.

CHANGED YOUR ADDRESS OR SOLD YOUR SUBARU?

If you have moved or sold your vehicle, please complete the enclosed postage prepaid postcard and mail it to us. Or, if you prefer to update this information online, please go to www.subaru.com, select Contact Us then select Update Address from the drop down menu.

IF YOU NEED FURTHER ASSISTANCE:

To locate the nearest Subaru Dealer you can access our website at www.subaru.com and select "Find a Dealer".

For additional information and for the most Frequently Asked Questions, please go to:

- <http://www.wqe41.service-campaign.com>

If you need additional assistance, please contact us directly:

- Telephone: 1-800-SUBARU3 (1-800-782-2783)
Monday through Thursday between 7:30 a.m. and 8:00 p.m. ET.
Friday between 10:30 a.m. and 5:00 p.m. ET
Saturday between 9:00 a.m. and 3:30 p.m. ET
- E-mail: Go to www.subaru.com and select "Contact Us".
- U.S. Postal mail: Write us at Subaru of America, Inc.
Attn: CDS Department, P.O. Box 6000, Cherry Hill, NJ 08034-6000.

Please contact us immediately if the dealer fails or is unable to make the necessary repairs free of charge.

You may also contact the Administrator, National Highway Traffic Safety Administration, 1200 New Jersey Ave. SE, West Building, Washington, DC 20590 or call the toll free Auto Safety Hotline at 1-888-327-4236 (TTY: 1-800-424-9153) or go to <http://www.safercar.gov> if you believe the dealer has failed or is unable to remedy your vehicle without charge within a reasonable amount of time.

Your continued satisfaction with your Subaru is important to us. Please understand that we have taken this action in the interest of your safety and your vehicle's proper operation. We sincerely apologize for any inconvenience this matter may cause and urge you to schedule an appointment as soon as possible to have this repair performed.

Sincerely,
Subaru of America, Inc.

Notice to Lessors: Under Federal law the lessor of a vehicle who receives this letter must provide a copy of it to the vehicle lessee(s) within 10 business days from receipt. The lessor must also keep a record of the lessee(s) to whom this letter is sent, the date sent, and the applicable vehicle identification number (VIN). (For the purposes of this section, a lessor means a person or entity that in the last twelve months prior to the date of this notification has been the owner, as referenced on the vehicle's title, of any five or more leased vehicles. A leased vehicle is a vehicle leased to another person for a term of at least four months.)

A subsidiary of Fuji Heavy Industries Ltd.

Continued...

OWNER NOTIFICATION LETTER VERSION 2



SUBARU

Subaru of America, Inc
Subaru Plaza
PO Box 6000
Cherry Hill, NJ 08034-6000
800-782-2783
www.subaru.com

**Important Safety Recall Notice
Subaru Recall Campaign WQE41-2
NHTSA Recall No. 12V-602
February 2013**

Dear Subaru Owner:

This notice is sent to you in accordance with the requirements of the National Traffic and Motor Vehicle Safety Act. SUBARU OF AMERICA, INC. has decided that a defect, which relates to motor vehicle safety, exists in some 2006 through 2012 model year Subaru vehicles equipped with optional Genuine Subaru Puddle Lights. If your vehicle is not equipped with optional puddle lights, this notice does not apply to you.

DESCRIPTION OF THE SAFETY DEFECT

Subaru has determined that certain vehicles equipped with optional left and right side puddle lights may develop a short circuit and cause related components to overheat and potentially melt.

A short circuit can develop when either the puddle lights or connectors are exposed to an electrolytic moisture source (i.e.- salt water) and it penetrates the circuit board of the puddle light or the pins of the puddle light connector(s).

DESCRIPTION OF THE SAFETY HAZARD

Puddle lights are mounted in the vehicle's left and right rocker panel trim and automatically illuminate the ground in the area near the doors when you enter and exit the vehicle. If the puddle lights or connectors were to overheat, they could melt and pose a risk of a fire.

REPAIRS

To correct this condition, Subaru will inspect and if necessary repair the puddle lights. If in-line fuses for both the left and right side puddle lights are not already installed, they will be added as a precautionary measure at no cost to you.

WHAT YOU SHOULD DO

If your vehicle is equipped with optional puddle lights or if you are unsure whether your vehicle is equipped with optional puddle lights, you should immediately contact your Subaru Dealer for an appointment to have your vehicle inspected and if necessary, this repair performed at no cost to you. If you are certain that your vehicle is not equipped with optional puddle lights, no further action is necessary.

There are several important precautions owners of vehicles equipped with optional puddle lights should take until this repair has been performed:

- If you notice or smell smoke in the left or right rocker panel area of the vehicle, be sure the ignition switch is in the "off" position and do not operate the vehicle. Immediately contact your Subaru dealer for assistance.
- As a precautionary measure, it is highly recommended that you not park your vehicle in a garage, car port or other structure.

HOW LONG WILL THE REPAIR TAKE?

The actual time to inspect your vehicle and, if necessary, install in-line fuses is approximately 30 minutes. Any other repairs could take up to an additional 25 minutes. However, it may be necessary to leave your vehicle for a longer period of time on the day of your scheduled appointment to allow your dealer flexibility in scheduling. Please present this letter to your Subaru Dealer at the time this repair procedure is performed.

Continued...

IF YOU HAVE PREVIOUSLY PAID FOR A REPAIR

If you have already paid for repairs associated with this condition, you may be eligible for reimbursement. Reimbursement consideration will be based on the amount an authorized Subaru dealer in your area would charge for performing those repairs.

Please send the original service repair order, which has the name of the repair facility, date of repair, mileage at the time of repair, complete vehicle identification number (17 digits), and your name, with correct mailing address and telephone number to the address listed below.

**Subaru of America, Inc.
Customer Dealer Services Department
Attention: WQE-41 Recall
P.O. Box 6000
Cherry Hill, NJ 08034-6000**

Please send original receipts only and retain a photocopy for your records. Please be assured that we will attempt to process your reimbursement request as quickly as possible, but it may take up to 60 days for this process to be completed.

CHANGED YOUR ADDRESS OR SOLD YOUR SUBARU?

If you have moved or sold your vehicle, please complete the enclosed postage prepaid postcard and mail it to us. Or, if you prefer to update this information online, please go to www.subaru.com, select Contact Us then select Update Address from the drop down menu.

IF YOU NEED FURTHER ASSISTANCE:

To locate the nearest Subaru Dealer you can access our website at www.subaru.com and select "Find a Dealer".

For additional information, including how to determine if your vehicle is equipped with puddle lights, and for the most Frequently Asked Questions, please go to:

- <http://www.wqe41.service-campaign.com>

If you need additional assistance, please contact us directly:

- Telephone: 1-800-SUBARU3 (1-800-782-2783)
Monday through Thursday between 7:30 a.m. and 8:00 p.m. ET.
Friday between 10:30 a.m. and 5:00 p.m. ET
Saturday between 9:00 a.m. and 3:30 p.m. ET
- E-mail: Go to www.subaru.com and select "Contact Us".
- U.S. Postal mail: Write us at Subaru of America, Inc.
Attn: CDS Department, P.O. Box 6000, Cherry Hill, NJ 08034-6000.

Please contact us immediately if the dealer fails or is unable to make the necessary repairs free of charge.

You may also contact the Administrator, National Highway Traffic Safety Administration, 1200 New Jersey Ave. SE, West Building, Washington, DC 20590 or call the toll free Auto Safety Hotline at 1-888-327-4236 (TTY: 1-800-424-9153) or go to <http://www.safercar.gov> if you believe the dealer has failed or is unable to remedy your vehicle without charge within a reasonable amount of time.

Your continued satisfaction with your Subaru is important to us. Please understand that we have taken this action in the interest of your safety and your vehicle's proper operation. We sincerely apologize for any inconvenience this matter may cause and urge you to schedule an appointment as soon as possible to have this repair performed.

Sincerely,
Subaru of America, Inc.

Notice to Lessors: Under Federal law the lessor of a vehicle who receives this letter must provide a copy of it to the vehicle lessee(s) within 10 business days from receipt. The lessor must also keep a record of the lessee(s) to whom this letter is sent, the date sent, and the applicable vehicle identification number (VIN). (For the purposes of this section, a lessor means a person or entity that in the last twelve months prior to the date of this notification has been the owner, as referenced on the vehicle's title, of any five or more leased vehicles. A leased vehicle is a vehicle leased to another person for a term of at least four months.)

A subsidiary of Fuji Heavy Industries Ltd.