



INSTRUCTION TO SERVICE

ITS: 5260	
SECTION:	204 Rear Suspension
WRITTEN BY:	K. Baziuk
SUBJECT:	Inspect Rear Brake Chambers. Remove & Replace Integrated Guide Chambers to O-Ring Guided Design.

ITS5260

THIS DOCUMENT AND THE CONTENTS DISCUSSED HEREIN ARE THE CONFIDENTIAL AND PROPRIETARY INFORMATION OF NEW FLYER INDUSTRIES CANADA ULC AND NEW FLYER OF AMERICA INC. AND ARE DISCLOSED BY NEW FLYER IN CONFIDENCE. THIS DOCUMENT AND THE CONTENTS HEREIN ARE NOT TO BE DISCLOSED BY THE INTENDED RECIPIENT WITHOUT THE PRIOR WRITTEN AUTHORIZATION OF NEW FLYER. ANY UNAUTHOIZED DISCLOSURE, REPRODUCTION OR OTHER DISTRIBUTION OF THIS DOCUMENT OR INFORMATION IS STRICTLY PROHIBITED AND MAY RESULT IN ACTION BEING TAKEN AGAINST THE PARTY MAKING THE UNAUTHORIZED DISCLOSURE. THIS DOCUMENT AND ALL COPIES HEREOF MUST BE RETURNED TO NEW FLYER UPON REQUEST.



NEW FLYER

PROCEDURE:

1. Turn the main battery disconnect switch to the “OFF” position.
2. Remove rear wheels and raise coach in accordance with the New Flyer Service Manual.
3. Locate rear axle brake chambers as shown per Figure 1.
4. Inspect date codes for both curb side and street side brake chambers. Use Figure 2 as a reference on where to find and read date codes.
 - a. If date codes fall within 112310 to 120611 (November 23, 2010 to December 6, 2011) inclusive, the brake chamber requires replacing and go to Step 4.
 - b. If date codes are outside 112310 to 120611 range, the brake chamber does not require replacing and go to Step 10.

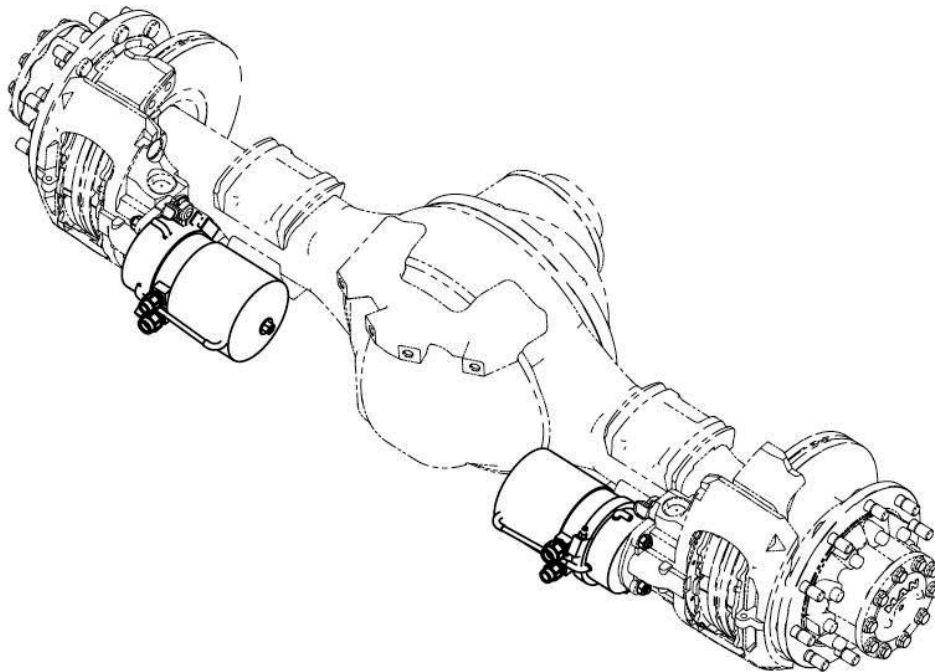

FIGURE 1: REAR AXLE

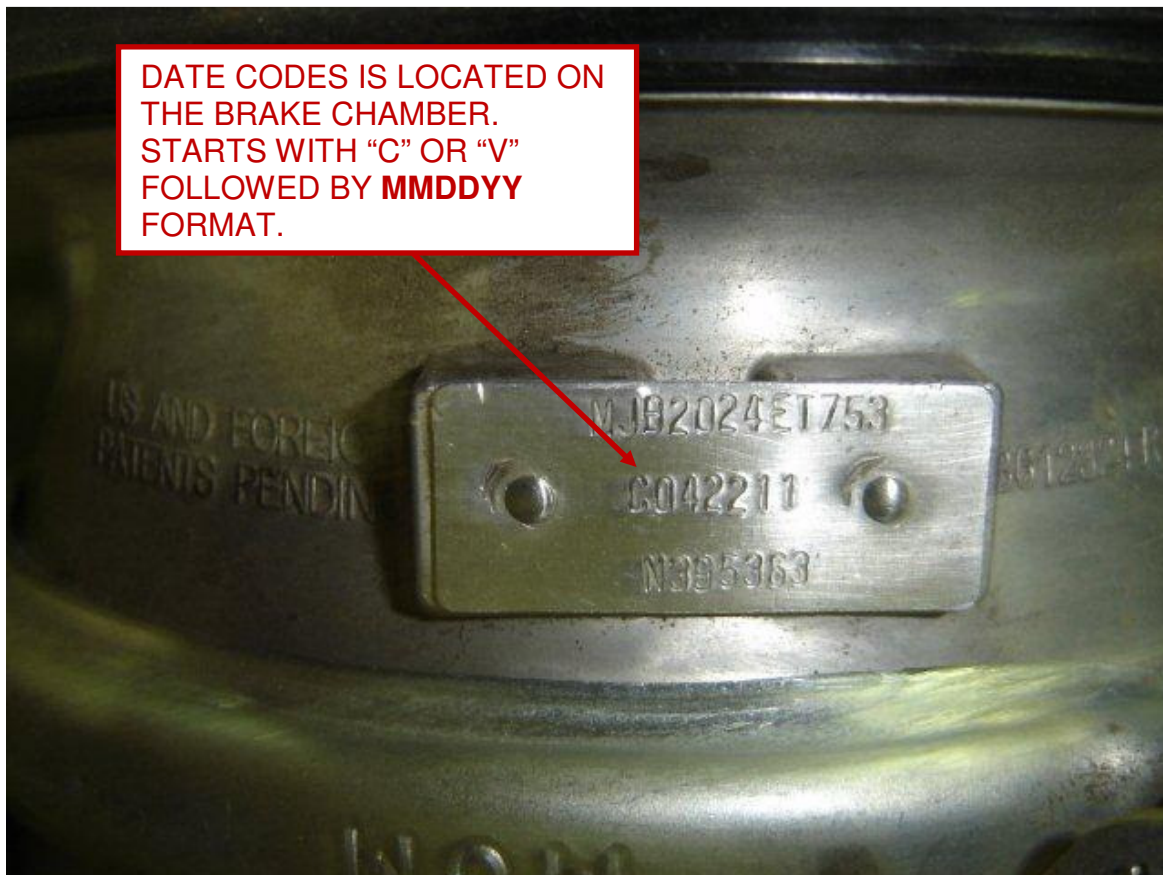

FIGURE 2: BRAKE CHAMBER DATE CODES

5. If rear brake chambers need to be replaced, they must be caged first. Follow chamber caging instructions to cage the brake chamber:
 - a. Release park brake.
 - b. Turn caging bolt counter-clockwise until it stops (approximately 22-23 turns). **Do not use air tools.** Do not exceed 74 ft-lbs. See Figure 3.
 - c. Apply park brake.
- NOTE:** Spring Brake must be fully caged before disconnection or removal. The brake chamber assembly is a non-serviceable unit and must be replaced as an assembly. Do NOT attempt to disassemble the brake chamber.

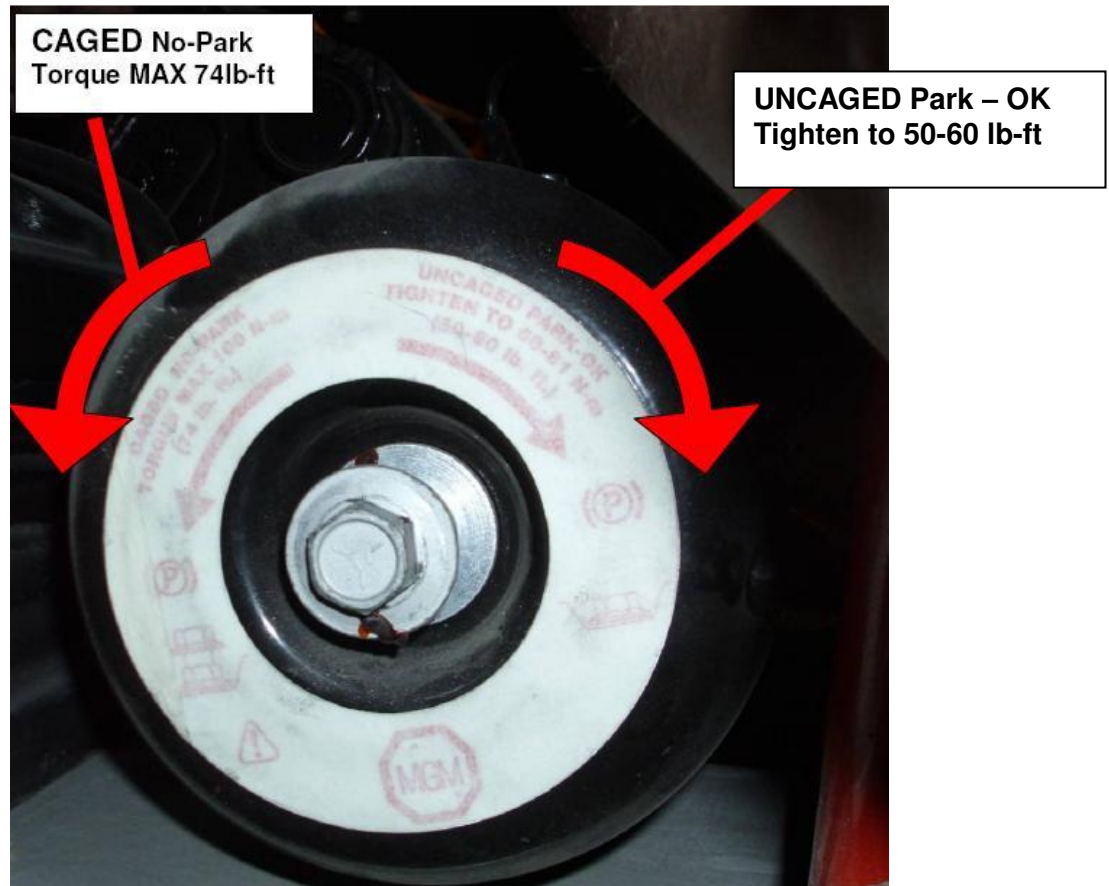

FIGURE 3: MGM CAGE & UNCAGE PROCEDURE

6. Use the following procedure to remove and replace the rear brake chambers (See Figure 4):
 - a. Clean brake chamber, caliper and surround area.
 - b. Disconnect both service and park brake hoses from brake chamber. Discard sleeves on hose ends.
 - c. Remove and discard hardware mounting the brake chamber to the rear axle and remove chamber.

NOTE: If bus is equipped with end-of-life sensors, there is a sheet metal wire guide attached to one of the chamber attaching bolts. Note the position and routing of this wire. Carefully remove and reattach to new chamber when installing. Wire is very fragile and can be damaged if mishandled.



NEW FLYER

- d. Remove fittings from old brake chamber and re-install on new brake chambers in the same locations.

☞ **NOTE: Clean and apply loctite (PN 8110442) to all pipe thread fittings. Ensure excess does not enter chamber ports.**

☞ **NOTE: Ensure no debris enters the sealed area of the brake caliper.**

- e. Carefully replace and reroute pad wear sensor harness and guide assembly to chamber stud (if applicable).
- f. Clean the mating faces of the brake chamber and the brake caliper.
- g. Apply grease (PN 6409051) to end of brake chamber pushrod prior to assembly.

☞ **NOTE: Do not use grease containing molybdenum disulphate.**

- h. Position the new brake chamber (PN 458277) on the caliper. Use the hardware supplied with the chamber. Apply never seize (PN 5928660) and torque to 133-155 ft-lbs. Apply torque marks.
- i. Reconnect service and park brake hoses to brake chambers using new sleeves (PN 6335083 for 1/2ID hose, PN 6335082 for 3/8ID hose).

7. Follow chamber uncaging instructions to uncage the brake chamber:

- a. Release park brake.
- b. Turn caging bolt clockwise until seated against head of brake chamber and tighten to 50-60 ft-lbs. **Do not use air tools.** Do not exceed 60 ft-lbs. See Figure 3.
- c. Apply park brake.

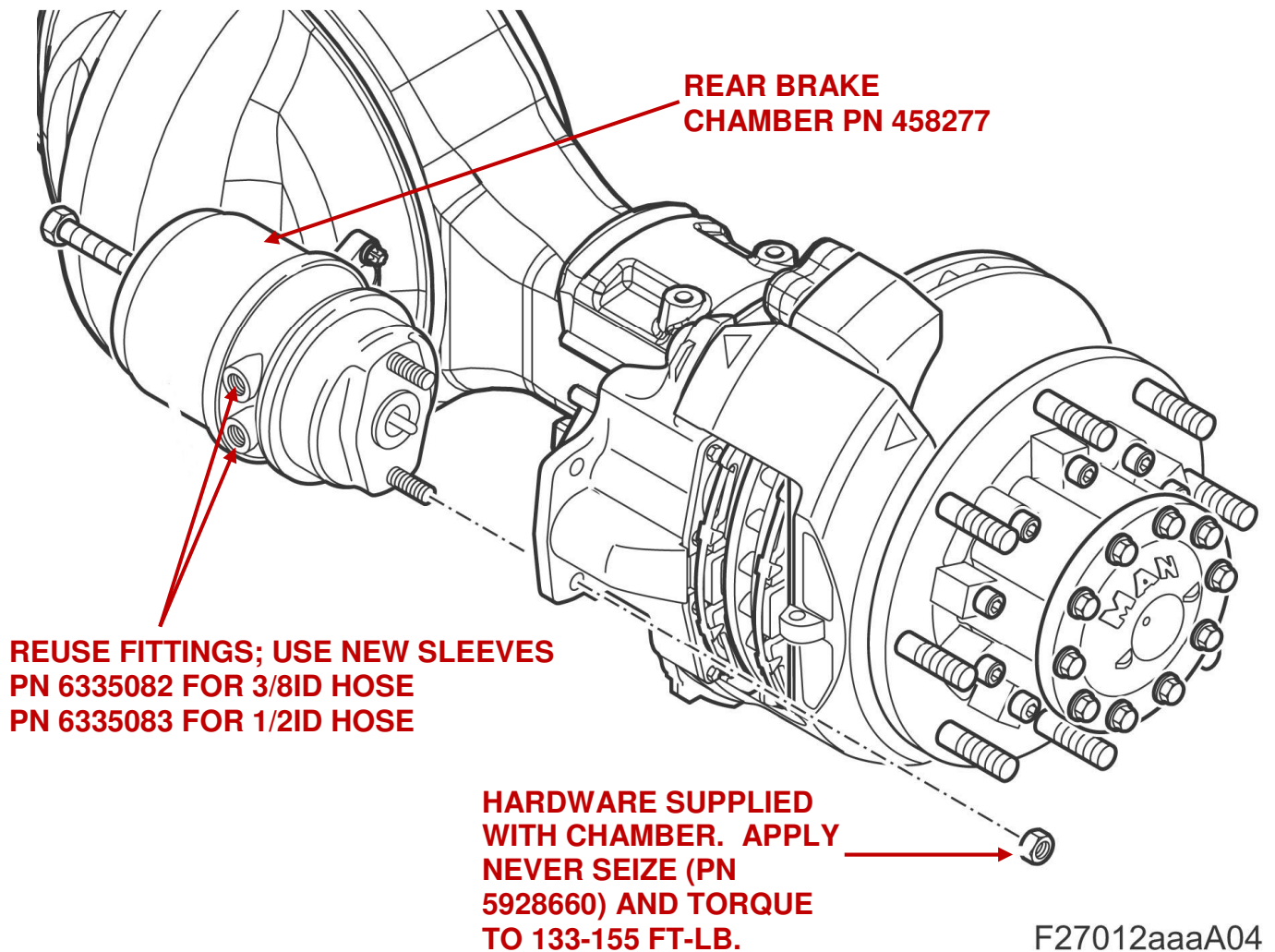

FIGURE 4: REAR AXLE BRAKE CHAMBER INSTALLATION

8. Release park brake and check for park brake leaks. Repair as required.
9. Apply service brake and check for service brake leaks. Repair as required.
10. Make multiple park brake apply and release applications to verify proper park brake function.
11. Perform Brake Pad Clearance Inspection:
 - a. Push the brake caliper fully inboard.
 - b. Insert a pry bar between the backing plate on the inboard brake pad and the caliper. Carefully pry brake pad away from the tappets.



NEW FLYER

- c. Use a feeler gauge to measure clearance between tappets and brake pad. Clearance should fall within the range of 0.027 to 0.047” (0.7 to 1.2 mm).
 - d. Check for properly functioning adjusters if clearance is outside of this range. Refer to “Automatic Adjustment Inspection” in the New Flyer Service Manual for checking procedure.
12. Reinstall rear wheels and torque in accordance with the New Flyer Service Manual.
 13. Lower coach in accordance with the New Flyer Service Manual.
 14. Turn the main battery disconnect switch to the “ON” position.



NEW FLYER

LABOUR ESTIMATE

	Operation	Men	Hours	Labour Time M X HR
1	Inspect Rear Brake Chambers. Remove & Replace Integrated Guide Chambers to O-Ring Guided Design.	1	2.5	2.5

PARTS REQUIRED

Item	Part Number	Description	Qty. per Coach	Units	Notes
1	458277	CHMBR-BRK MGM PISTON	2	EA	
2	6335082	SLEEVE – 3/8"	2	EA	
3	6335083	SLEEVE – 1/2"	2	EA	
4	8110442	LOCTITE 567 – THREAD SEALANT	.01	EA	
5	5928660	NEVER SEIZE	.01	EA	
6	6409051	GREASE RENOLIT HLT2	.01	EA	

SPECIAL TOOLS REQUIRED

Item	Part Number	Description	Qty. per Coach	Units	Notes
		No Special Tools Required			