



INSTRUCTION TO SERVICE

ITS: 5248	
SECTION:	204 Rear Suspension
WRITTEN BY:	K. Baziuk
SUBJECT:	Inspect Rear Brake Chambers. Remove & Replace Integrated Guide Chambers to O-Ring Guided Design.

ITS5248

THIS DOCUMENT AND THE CONTENTS DISCUSSED HEREIN ARE THE CONFIDENTIAL AND PROPRIETARY INFORMATION OF NEW FLYER INDUSTRIES CANADA ULC AND NEW FLYER OF AMERICA INC. AND ARE DISCLOSED BY NEW FLYER IN CONFIDENCE. THIS DOCUMENT AND THE CONTENTS HEREIN ARE NOT TO BE DISCLOSED BY THE INTENDED RECIPIENT WITHOUT THE PRIOR WRITTEN AUTHORIZATION OF NEW FLYER. ANY UNAUTHOIZED DISCLOSURE, REPRODUCTION OR OTHER DISTRIBUTION OF THIS DOCUMENT OR INFORMATION IS STRICTLY PROHIBITED AND MAY RESULT IN ACTION BEING TAKEN AGAINST THE PARTY MAKING THE UNAUTHORIZED DISCLOSURE. THIS DOCUMENT AND ALL COPIES HEREOF MUST BE RETURNED TO NEW FLYER UPON REQUEST.



NEW FLYER

PROCEDURE:

1. Turn the main battery disconnect switch to the “OFF” position.
2. Raise coach in accordance with the New Flyer Service Manual.
3. Locate rear axle brake chambers as shown per Figure 1.
4. Inspect date codes for both curb side and street side brake chambers. Use Figure 2 as a reference on where to find and read date codes.
 - a. If date codes fall within 011211 to 121311 (January 12, 2011 to December 13, 2011) inclusive, the brake chamber requires replacing and go to Step 6.
 - b. If date codes are outside 011211 to 121311 range, the brake chamber does not require replacing and go to Step 9.

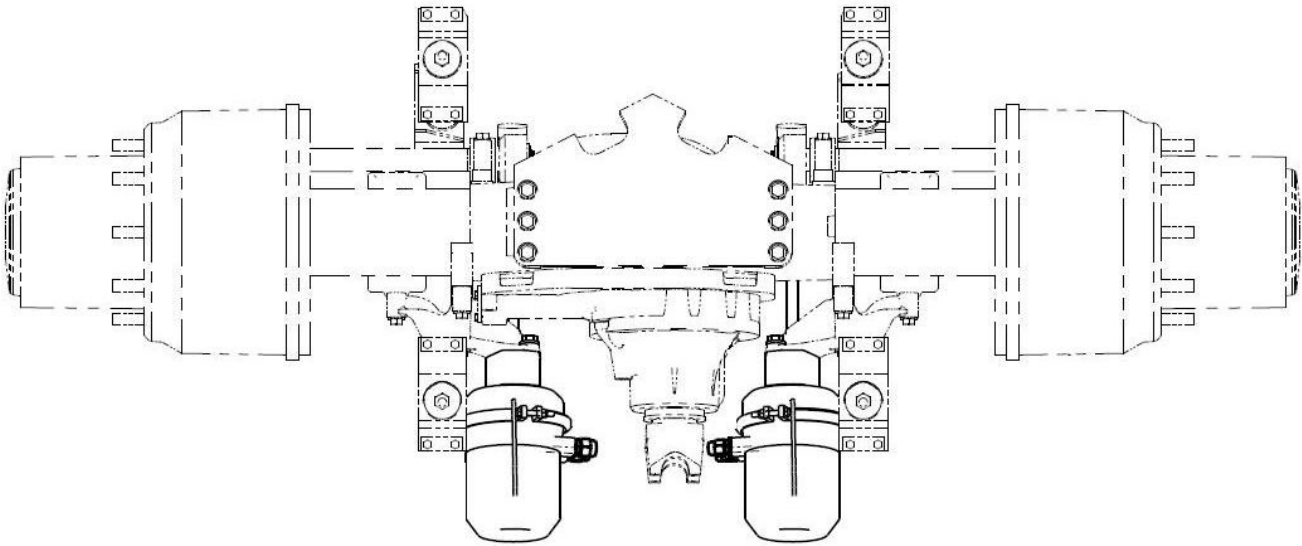

FIGURE 1: REAR AXLE

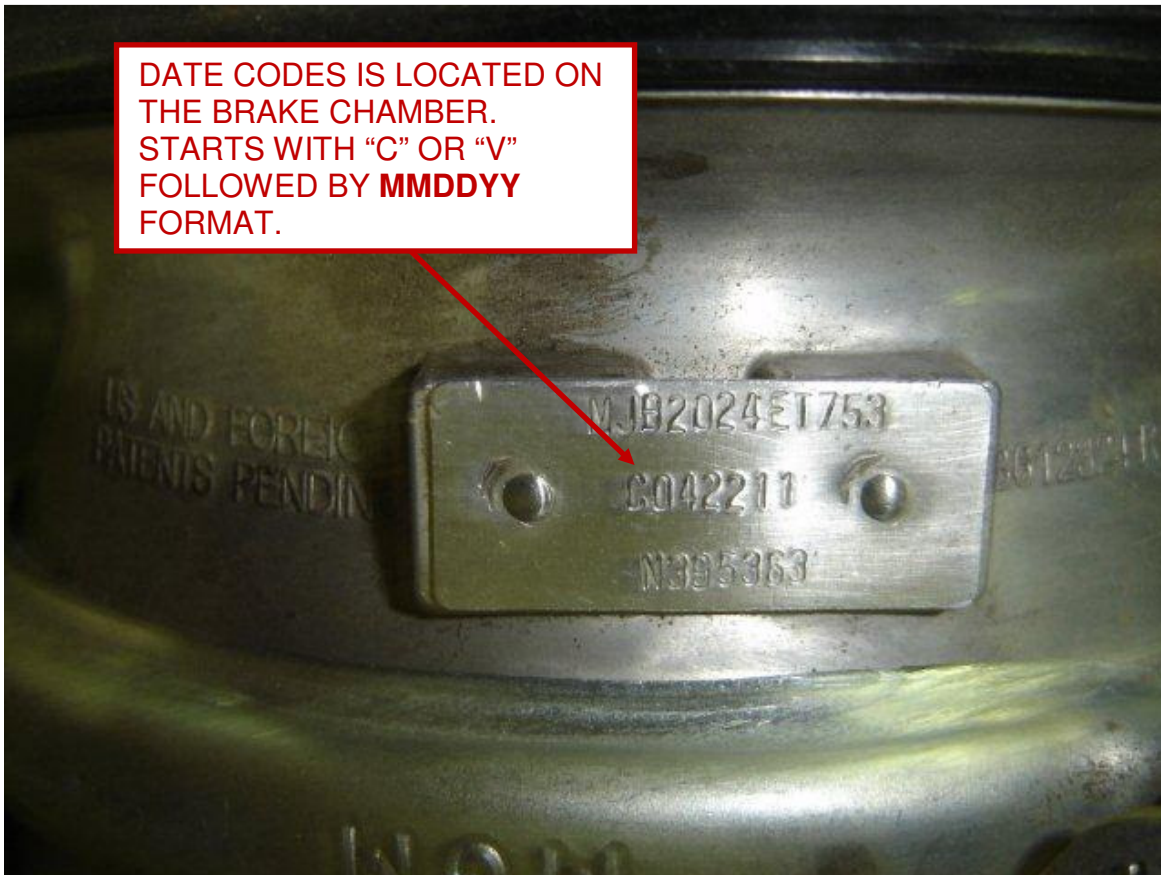

FIGURE 2: BRAKE CHAMBER DATE CODES

5. If brake chambers need to be replaced, they must be caged first. Follow chamber caging instructions to cage the brake chamber:
 - a. Release park brake.
 - b. Turn caging bolt counter-clockwise until it stops (approximately 22-23 turns). Do not use air tools. Do not exceed 74 ft-lbs. See Figure 3.
 - c. Apply park brake.
- ☞ NOTE: Spring Brake must be fully caged before disconnection or removal. The brake chamber assembly is a non-serviceable unit and must be replaced as an assembly. DO NOT attempt to disassemble the brake chamber.**

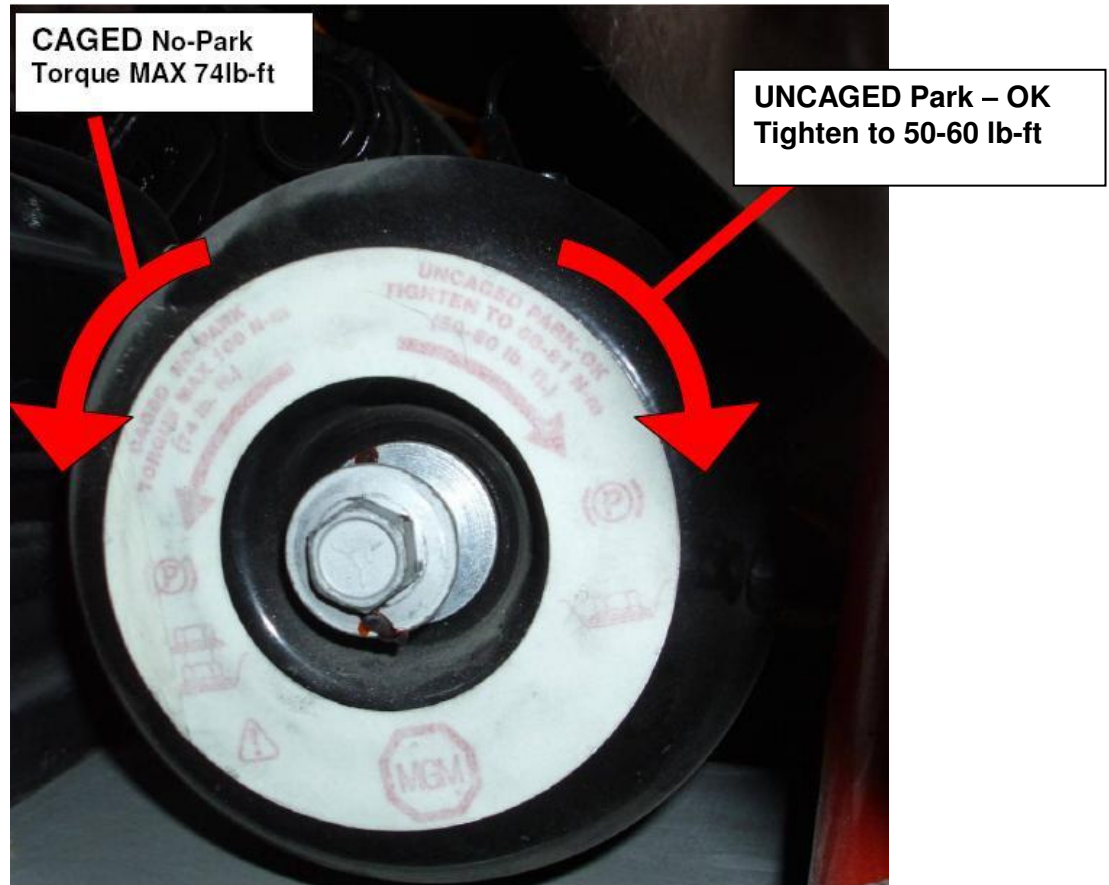

FIGURE 3: MGM CAGE & UNCAGE PROCEDURE

6. Use the following procedure to remove and replace the brake chambers, See Figure 4:
 - a. Disconnect both service and park brake hoses from brake chamber. Discard sleeves on hose ends.
 - b. Remove clevis pin to disconnect brake chamber pushrod yoke from slack adjuster.
 - c. Remove and discard the hardware mounting the brake chamber to the rear axle.
 - d. Remove spacers from old brake chambers (if applicable) and install on new brake chambers (Ref. PN 253137 and PN 253075).
 - e. Remove fittings from old brake chamber and re-install on new brake chambers in the same locations and orientation.



☞ **NOTE: Clean and apply loctite (PN 8110442) to all pipe thread fittings. Ensure excess does not enter chamber ports.**

- f. Mount brake chamber onto axle using hardware supplied with chambers. Apply never seize (PN 5928660) and torque to 133 – 155 ft-lbs.
 - g. Using clevis pin and hardware supplied with brake chamber, connect brake chamber pushrod to slack adjuster.
 - h. Reconnect service and park brake hoses to brake chambers using new sleeves (PN 6335083 for 1/2ID hose, PN 6335082 for 3/8ID hose).
7. Follow chamber uncaging instructions to uncage the brake chamber:
- a. Release park brake.
 - b. Turn caging bolt clockwise until seated against head of brake chamber and tighten to 50-60 ft-lbs. Do not use air tools. Do not exceed 60 ft-lbs. See Figure 3.
 - c. Apply park brake.

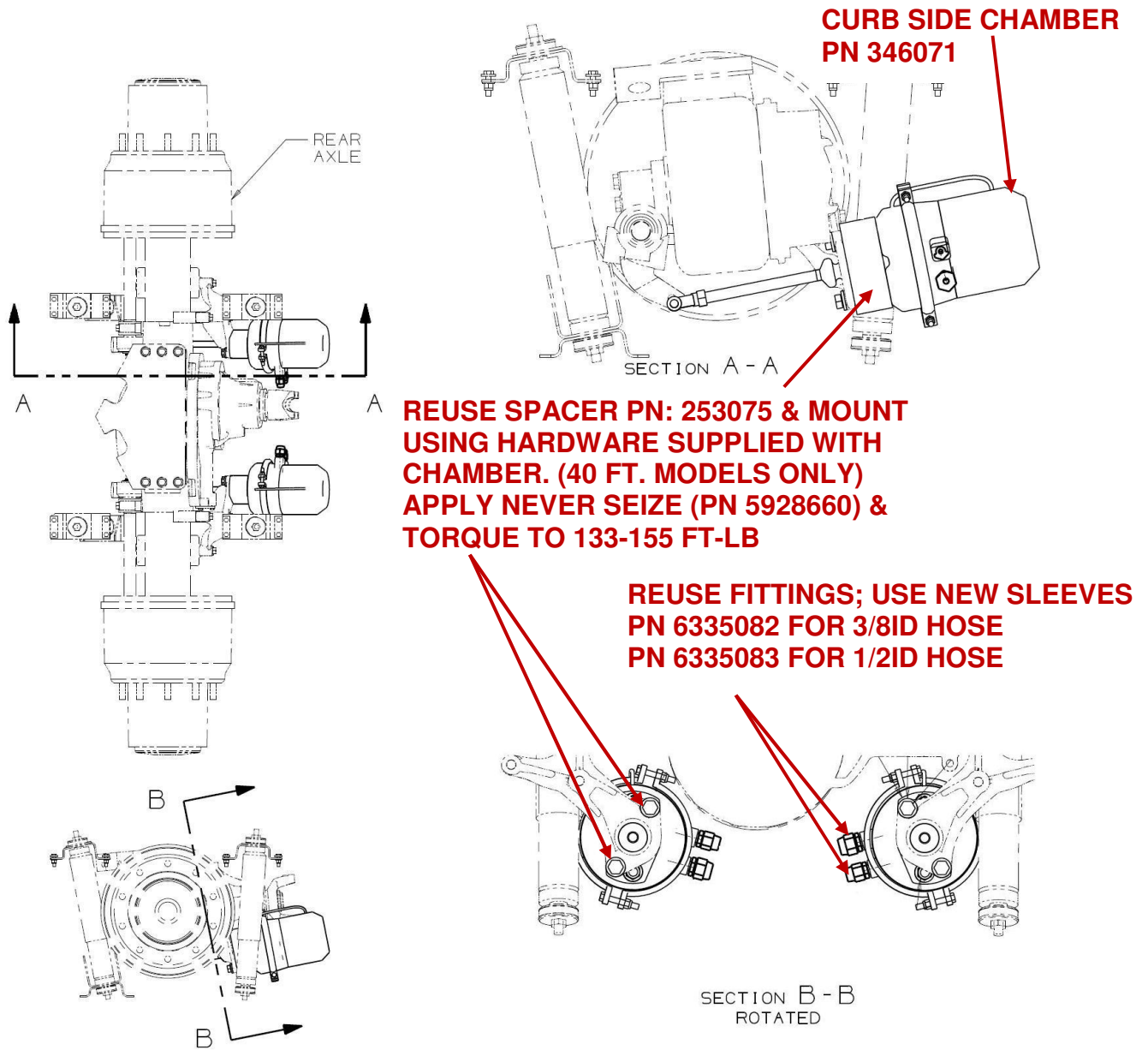

FIGURE 4: REAR AXLE BRAKE CHAMBER INSTALLATION



NEW FLYER

8. Perform slack adjuster adjustment for every brake chamber replacement in accordance with the New Flyer Service Manual. Appendix A has the applicable section for slack adjuster adjustment from the service manual.
9. If coach is 60 foot model, locate center axle brake chambers as shown per Figure 5.

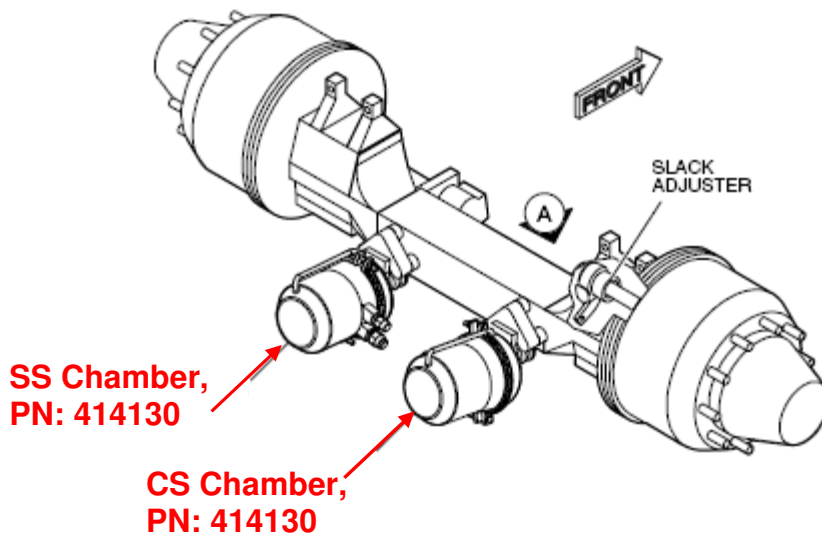

FIGURE 5: CENTER AXLE

10. Repeat steps 4 through 8 for center brake chamber replacement, See figure 6.

**APPLY NEVER SEIZE (PN 5928660) &
TORQUE TO 133-155 FT-LB**

**REUSE FITTINGS; USE NEW SLEEVES
PN 6335082 FOR 3/8ID HOSE
PN 6335083 FOR 1/2ID HOSE**

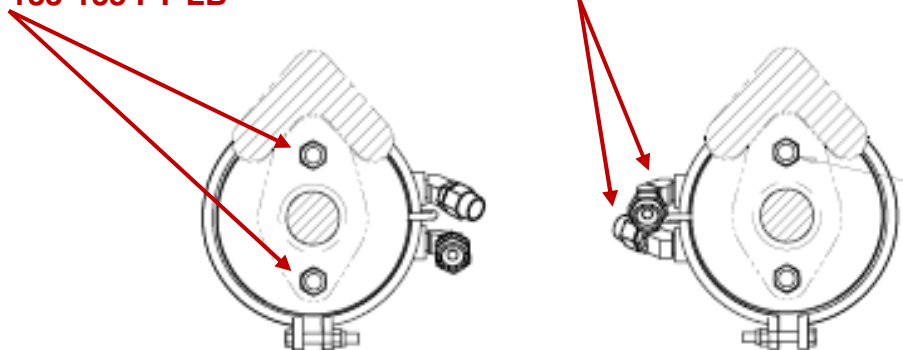



FIGURE 6: CENTER AXLE BRAKE CHAMBER INSTALLATION

11. Release park brake and check for park brake leaks. Repair as required.
12. Apply service brakes and check for service brake leaks. Repair as required.
13. Make multiple park brake apply and release applications to verify proper park brake functions.
14. Lower coach in accordance with the New Flyer Service Manual.
15. Turn the main battery disconnect switch to the "ON" position.



NEW FLYER

APPENDIX A – SLACK ADJUSTER ADJUSTMENT



NEW FLYER

REAR AUTOMATIC SLACK ADJUSTER

5.9.9. Slack Adjuster Adjustment

NOTE:

The slack adjuster will need to be manually adjusted immediately following a brake reline. Subsequent adjustments will occur automatically as the slack adjuster compensates for increased clearances due to brake lining wear.

5.9.9.1. Manual Adjustment

1. Rotate the adjusting hex nut clockwise until the brake shoe lining contacts the brake drum.
2. Back off the slack adjuster by rotating the adjusting hex bolt counter-clockwise 1/2 to 3/4 of a turn.

NOTE:

A minimum torque of 13 ft-lb. should be required to rotate the adjusting bolt counter-clockwise. A ratcheting sound should also be heard during this procedure.

3. Disconnect the slack adjuster arm from the push rod clevis and confirm that the control arm is properly positioned by pressing the operating arm of the slack adjuster toward the brake chamber.
4. If the arm of the slack adjuster does not move, then the control arm is properly adjusted and the clevis pin and cotter pin can be reinstalled.
5. If the arm of the slack adjuster moves, then the control arm needs to be adjusted. Refer to 5.9.9.2. "Control Arm Adjustment" on page 99 in this instruction for adjustment procedure.

5.9.9.2. Control Arm Adjustment

1. Loosen the nuts on the mounting pin of the control arm.
2. Rotate the slack adjuster control arm in the normal direction of camshaft rotation until it comes to a definite internal stop.
3. Thread the inner and outer control arm mounting nuts against each other to lock the control arm in position. Torque the nuts to 17 ft-lb. (23 Nm). See "Fig. 2-103: Control Arm Adjustment" on page 99.

NOTE:

Ensure that the control arm is not under tension when tightened.

4. Reconnect the slack adjuster to the push rod clevis.
5. Make a full pressure brake application and then release. Also ensure parking brake is released.
6. Confirm that the notch in the wear indicator aligns with the marking on the end of the camshaft. See "Fig. 2-104: Slack Adjuster Index Markings" on page 99.

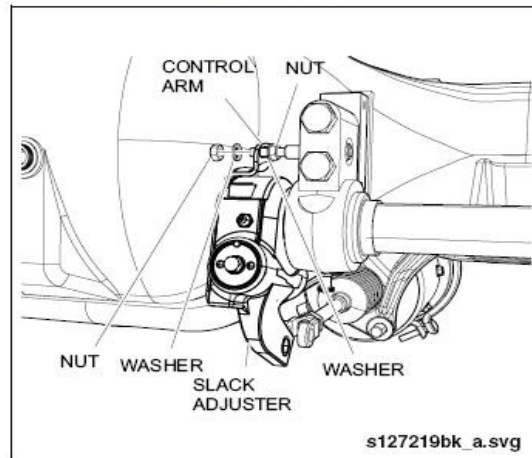

Fig. 2-103: Control Arm Adjustment

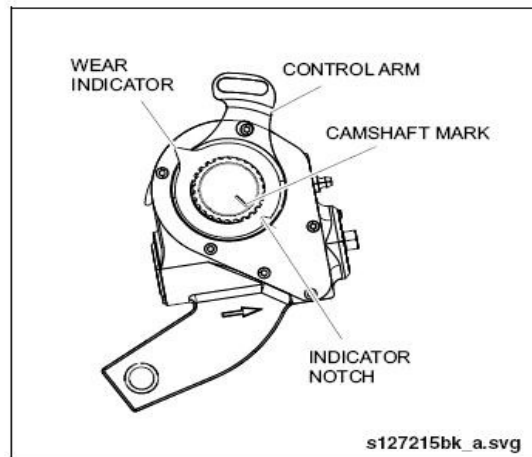

Fig. 2-104: Slack Adjuster Index Markings



NEW FLYER

LABOUR ESTIMATE

	Operation	Men	Hours	Labour Time M X HR
1	Inspect Rear Brake Chambers. Remove & Replace Integrated Guide Chambers to O-Ring Guided Design.	1	1.50	1.50
2	Inspect Center Brake Chambers. Remove & Replace Integrated Guide Chambers to O-Ring Guided Design.	1	1.0	1.00

PARTS REQUIRED

Item	Part Number	Description	Qty. per Coach	Units	Notes
1	346070	CHMBR-BRK MGM PISTON, SS	1	EA	
2	346071	CHMBR-BRK MGM PISTON, CS	1	EA	
3	6335082	SLEEVE – 3/8"	2	EA	
4	6335083	SLEEVE – 1/2"	2	EA	
5	8110442	LOCTITE 567 – THREAD SEALANT	.01	EA	
6	5928660	NEVER SEIZE	.01	EA	
7	414130	ASSY-BRK CHMBR MGM CTR, SS CS	2	EA	ADD IF 60 FT COACH
9	6335082	SLEEVE – 3/8"	2	EA	ADD IF 60 FT COACH
10	6335083	SLEEVE – 1/2"	2	EA	ADD IF 60 FT COACH

SPECIAL TOOLS REQUIRED

Item	Part Number	Description	Qty. per Coach	Units	Notes
		No Special Tools Required			