



# SERVICE BULLETIN

SB1246

<b>ADDRESSEES</b>	: Owners and operators of coaches listed under 'Application'
<b>VEHICLE MODEL</b>	: C2045, T2140, T2145
<b>SYSTEM/SUBSYSTEM</b>	: Electrical system
<b>BULLETIN TYPE</b>	: Safety Recall NHTSA 12V-495/ TC 2012-344
<b>DATE</b>	: November 12, 2012
<b>SUBJECT</b>	: <b>Alternators mounted on Detroit Diesel engine – To add ground cables</b>
<b>TERMS &amp; CONDITIONS</b>	: Refer to the warranty section further in this Bulletin.

## APPLICATION:

The recall campaign, subject of this Bulletin is applicable to following units:

<b>Model</b>	<b>VIN</b>
C2045	47701 → 47775
T2140	40630 → 40634
T2145	44701 → 44758

## DESCRIPTION:

1. Van Hool NV has decided that a defect which relates to motor vehicle safety exists in the above-mentioned coaches, equipped with a Detroit Diesel DD13 engine without ground cables installed on the Prestolite AC172 alternators.
2. The alternator might fail due to excessive heat caused by a progression of the inter-surface corrosion of the electric path of the minus diode plates. The alternator components may melt, possible resulting in smoke and creating a risk for a potential fire hazard.
3. The remedy is to fit a ground cable to both alternators mounted on the engine. For this purpose, ground cables have been made available. Refer to the procedure in this Service bulletin for fitting instructions. The terms and conditions of the campaign have been detailed in the warranty section.

*Continued on next page*

## **MATERIAL:**

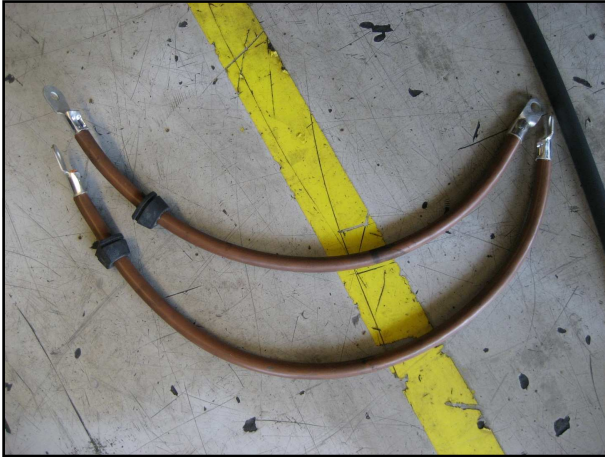

**Figure 1: Alternator ground cables**

<b>VH reference</b>	<b>Description</b>	<b>Qty.</b>
11271513	Set of two ground cables (with grommets)	1
660224301	Screw	1
660627920	Washer	1

Material may be obtained through regular channels.

## **PROCEDURE: To add alternator ground cables**

### **1. General:**

- This job has to be carried out by a technician proficient in automotive electrics.
- For more information refer to the service literature that comes with the vehicle.

### **2. Special tools, equipment or services:**

- This job does not require special tools, equipment nor services.

### **3. Preparations:**

- Park the vehicle safely, apply the parking brake, stop the engine, switch off all systems and turn off the master switch on the dashboard.
- Turn off the mechanical battery switch.
- Put a "DO NOT OPERATE" tag on the instrument panel.
- Read the entire procedure before beginning to work.
- Observe safe shop practices at all times.

*Continued on next page*

**4. To add alternator ground cables:**

- 1) Open the exterior door of the radiator compartment.
- 2) Remove the access panel in front of the radiator (Figure 2).

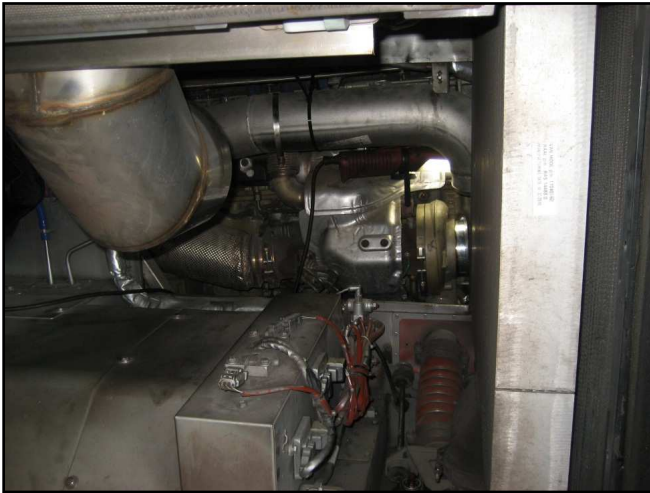

**Figure 2**

- 3) Remove the rubber hose at the turbocharger (Figure 3).



**Figure 3**

*Continued on next page*

- 4) Remove the air hose connected to the protective cover of both alternators.
- 5) At the upper alternator only: remove the nuts securing the positive cable clamp to the cable support (Figure 4).

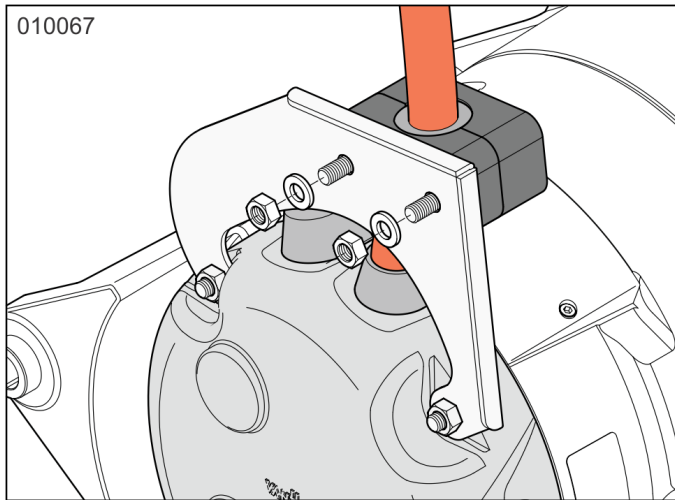

**Figure 4**

- 6) At the upper alternator only: remove the cable support.
- 7) Re-install the nuts to prevent cable clamp falling to pieces.
- 8) Remove the protective cover of both alternators (Figure 5 shows protective cover of upper alternator).

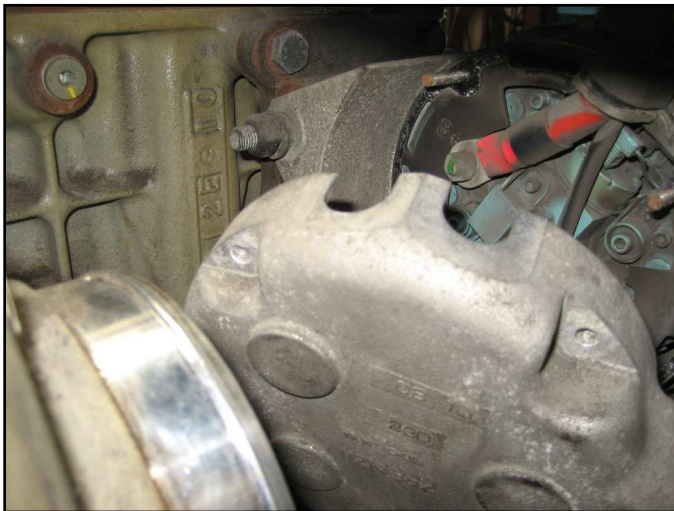

**Figure 5**

*Continued on next page*

- 9) Slacken the terminal nut of the red positive cables. Re-route the positive cables so that they will pass afterwards through the left hole of the protective cover. Re-tighten the terminal nut of the positive cables to a torque of 6.6 to 9.6 ft.lbf (9 to 13 Nm) (Figure 6 shows upper alternator).

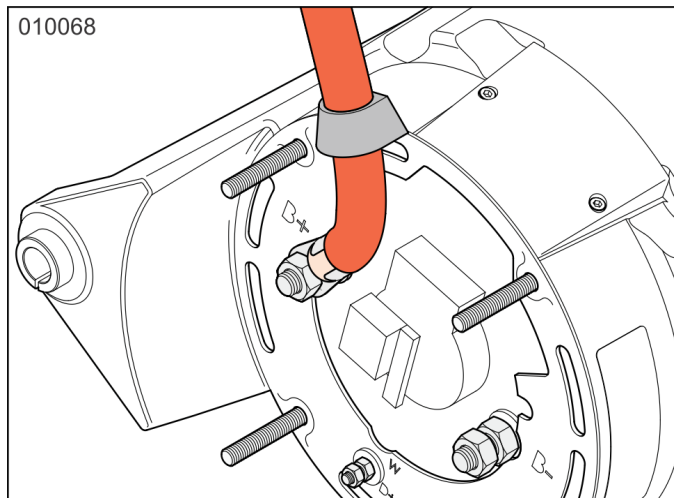

**Figure 6**

- 10) Install the ground cables on both alternators. Route the ground cables so that they will pass afterwards through the right hole of the protective cover. Re-tighten the terminal nut of the ground cables to a torque of 6.6 to 9.6 ft.lbf (9 to 13 Nm) (Figure 7 shows upper alternator).

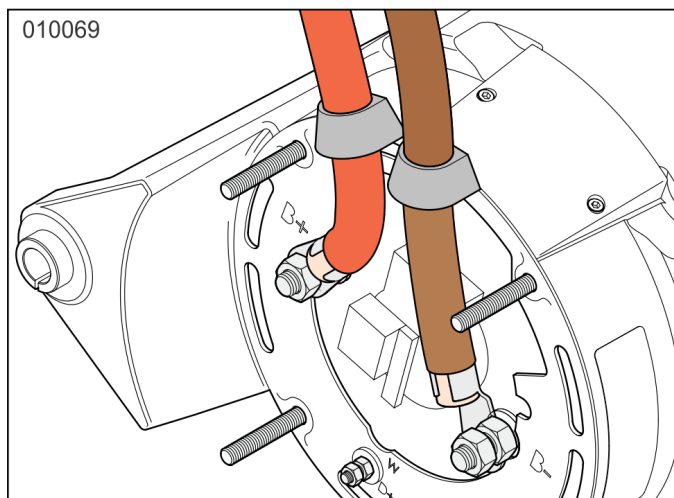
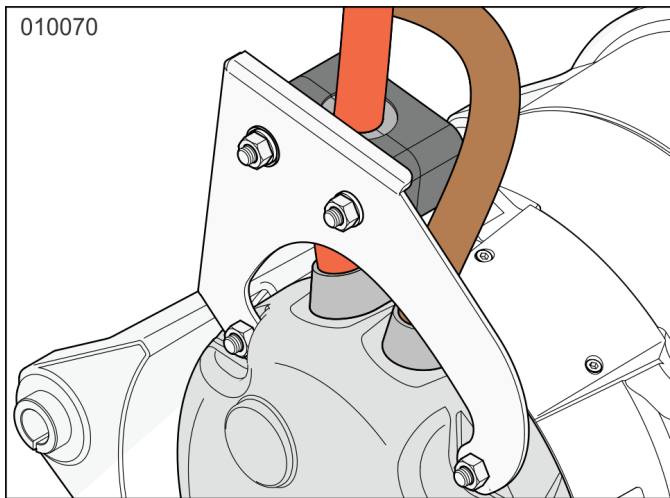

**Figure 7**

- 11) Re-install the protective cover of the lower alternator. Verify that the rubber grommets for the cables are in place.

*Continued on next page*

- 12) Install the protective cover of the upper alternator. Verify that the rubber grommets for the cables are in place. Install the positive cable support in reverse of original position and secure the cable clamp to the support. Secure the protective cover (Figure 8).



**Figure 8**

- 13) Reconnect the air hose at the rear of both alternators.
- 14) Secure the ground cable of both alternators to the engine block. Tightening torque of screw: 16 ft.lbf (21 Nm) (Figure 9).

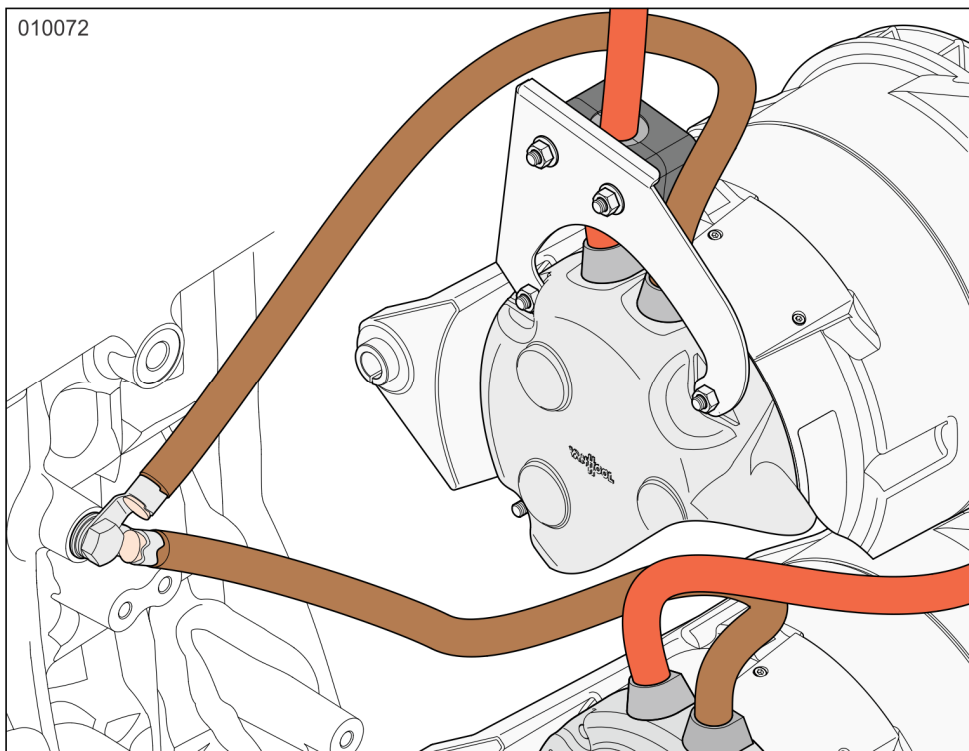

**Figure 9**

- 15) Re-install the rubber hose at the turbocharger.
- 16) Re-install the access cover in the radiator compartment.

*Procedure complete.*

*Continued on next page*

**ATTACHMENTS:**

None

**WARRANTY:**

**1. Application:**

The recall campaign, subject of this Bulletin is applicable to following units:

<b>Model</b>	<b>VIN</b>
C2045	47701 → 47775
T2140	40630 → 40634
T2145	44701 → 44758

**2. Terms and conditions:**

**CAUTION: Owners are required to certify on and return the OWNER'S CERTIFICATION LETTER, which has been included with the Owner Notification Letter that the recall remedy has been carried out in accordance with the manufacturer's instructions.**

Van Hool/ABC-Companies will accept warranty claims for this repair as follows:

**Parts:**

- Supply: parts will be supplied through regular channels, free of charge.
- Return: none

**Labor allowance:** 3 hours of labor will be awarded per unit repaired.

**Campaign expiration/target date:** Service Bulletin issue date + 1 year

**3. Claim references:**

- Job code: O06043N

**Claim submission:** If there are any questions regarding this campaign, please call ABC Customer Care & Parts Source toll-free for guidance on 1-877-427-7278. Listen for the prompts for warranty and select that option.

**INFORMATION HANDLING:**

Important supplements to and modifications of the technical information not yet included in the Van Hool manuals are communicated by means of Service Bulletins.

File the Service Bulletins at the back of your manual, in numerical order.

To make sure that you will be reminded of the Bulletins that have appeared in the meantime while paging the manual, mark the pages concerned by hand with the Service Bulletin number.

**VAN HOOL/ABC-COMPANIES**

**THIS PAGE HAS BEEN LEFT BLANK INTENTIONALLY**