



Applies To: **2002-06 CR-V** –
ALL VINs Beginning with SHS – Check the iN VIN Status Inquiry

January 18, 2013

Safety Recall: 2002-06 CR-V Driver's Power Window Switch Does Not Work or Works Intermittently

(Supersedes 12-067, dated November 2, 2012, to revise the information marked by the black bars)

REVISION SUMMARY

- Under CORRECTIVE ACTION and WARRANTY CLAIM INFORMATION, information was changed.
- Under INSPECTION PROCEDURE, most of the procedure was changed.
- Under REPAIR PROCEDURE A, images were changed.
- Under REPAIR PROCEDURE B, steps were deleted.

BACKGROUND

Under severe conditions, water or other liquid may enter the driver's window and reach the power window master switch on the door panel. Liquid in the switch can damage the switch's printed circuit board (PCB), causing the switch to fail. In rare cases, the damaged PCB creates a short circuit that overheats the switch connectors and melts them, leading to a possible fire.

CUSTOMER NOTIFICATION

Owners of affected vehicles will receive a notification of this campaign.

Do an **iN VIN status inquiry** to make sure the vehicle is shown as eligible.

Some vehicles affected by this campaign may be in your used vehicle inventory. These vehicles **must** be repaired before they are sold.

Should your dealership sell an unrepaired vehicle that subsequently causes injury or damage because of the recalled item, the dealership will be solely responsible to the damaged party, and will be required to defend and indemnify American Honda for any resulting claims. To see if a vehicle in inventory is affected by this recall, do a VIN status inquiry before selling it.

CORRECTIVE ACTION

Inspect the power window master switch. Depending on what you find, do one of these actions:

- Apply a strip of butyl tape to seal the openings in the original switch assembly, and add a protective skirt to the switch.
- Install an updated switch.
- Replace the driver's door wire harness, and install an updated switch.

PARTS INFORMATION

NOTE:

- Damage to the driver's power window master switch is rare; the replacement rate is about 1 percent. Order the power window master switch only after confirming that replacement is needed.
- Make sure that you replace the switch with the updated part listed below. Do not use parts from existing inventory.

Driver's Power Window Master Switch Seal Kit:
P/N 35752-S9A-305

Driver's Power Window Master Switch Kit:
P/N 06357-S9A-305

TOOL INFORMATION

KTC Trim Tool Set: T/N SOJATP2014

WARRANTY CLAIM INFORMATION

OP#	Description	FRT
7440A7	Inspect and test the power window master switch, and apply butyl tape and plastic sheet to the original switch.	0.7
7441C9	Inspect, test, and replace the power window master switch.	0.6
7441D0	Inspect and replace the power window master switch and switch harness.	0.8

Failed Part: P/N 35750-S9A-C05ZA

Defect Code: 5WN00

Symptom Code: S6100

Skill Level: Repair Technician



CUSTOMER INFORMATION: The information in this bulletin is intended for use only by skilled technicians who have the proper tools, equipment, and training to correctly and safely maintain your vehicle. These procedures should not be attempted by "do-it-yourselfers," and you should not assume this bulletin applies to your vehicle, or that your vehicle has the condition described. To determine whether this information applies, contact an authorized Honda automobile dealer.

INSPECTION PROCEDURE

1. Make sure the window is up, then using the appropriate trim tool, pry out the upper portion of the cover to release the hooks, then remove the cover.

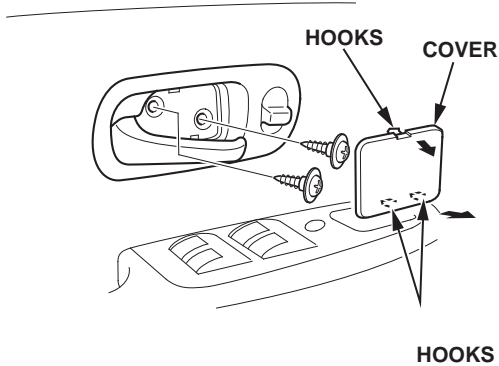

2. Remove the screws.
3. Release the power door lock switch bracket from the door panel by pulling the inner handle rearward and out halfway.

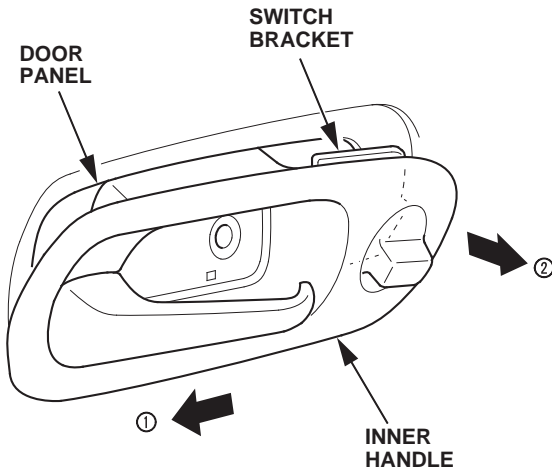

4. Disconnect the power door lock switch connector. Disconnect the inner handle rod, and remove the inner handle.

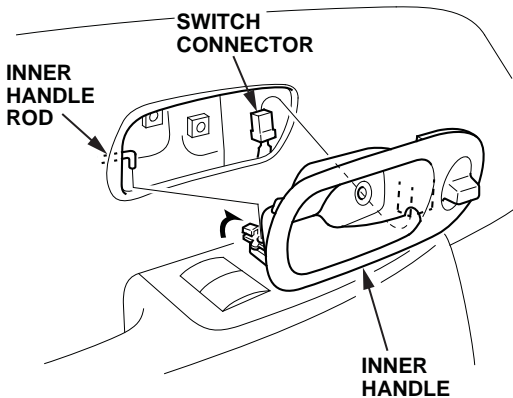

5. Remove the screws from under the armrest.

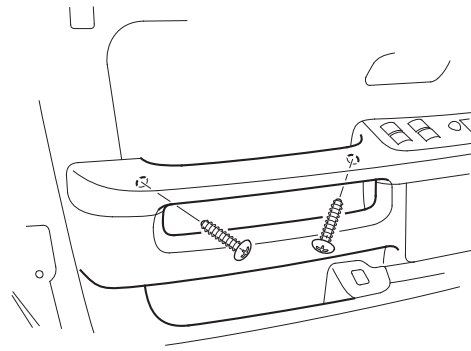

6. Carefully pry out the mirror mount cover by hand in the sequence shown.

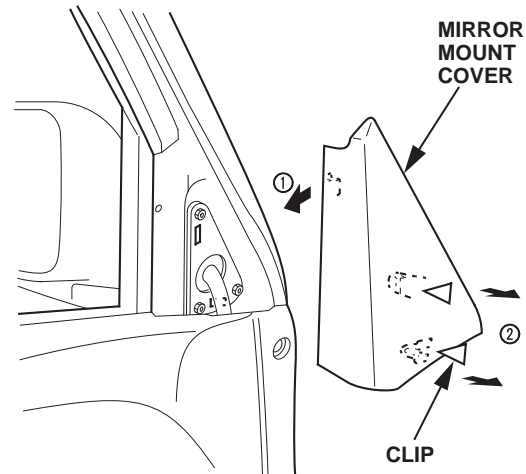

7. Remove the door panel.

- Remove the clip.

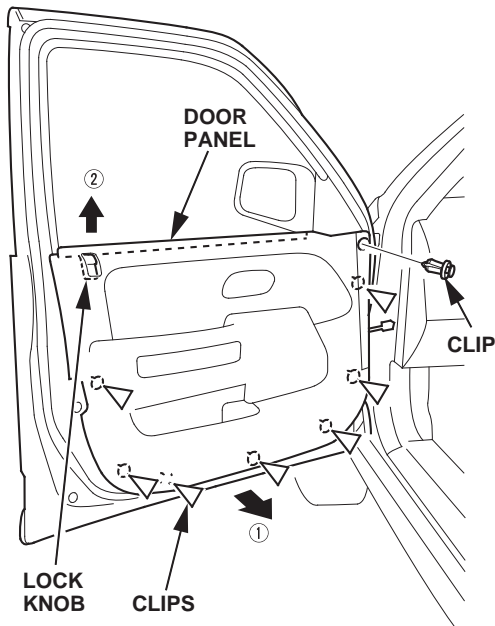

- With the appropriate trim tool, pry up to release the clips that hold the door panel.
- Starting at the rear, pull the door panel upward, then release the lock knob.

8. Disconnect the power window switch connector, the power mirror switch connector, and the hatch glass opener switch connector, and detach the harness clips from the back of the door panel.

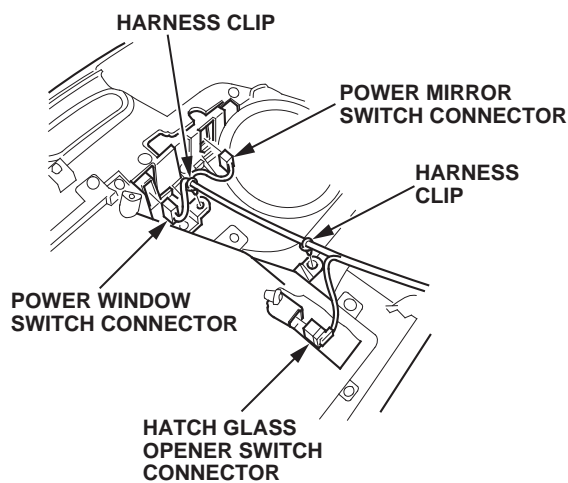

9. Push up on the bottom of the power window switch to release the clip and the hooks, then remove the switch.

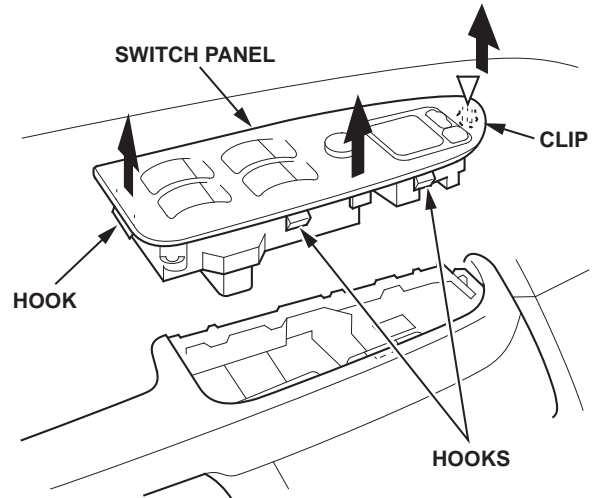

10. Inspect the power window switch and the driver's door harness connector for any heat damage or melting.

- If there is any damage to the power window master switch and/or the harness connector, go to REPAIR PROCEDURE B.
- If there is no damage to the power window master switch or the driver's door harness connector, go to step 11.

11. Measure the resistance between window switch terminal No. 4 and No. 14.

- If the resistance is less than 10k ohms, replace the power window master switch, then reinstall the door panel, the mirror mount cover, and the door lock switch. The repair is complete.
- If the resistance is at least 10k ohms, the power window master switch is OK. Go to REPAIR PROCEDURE A.

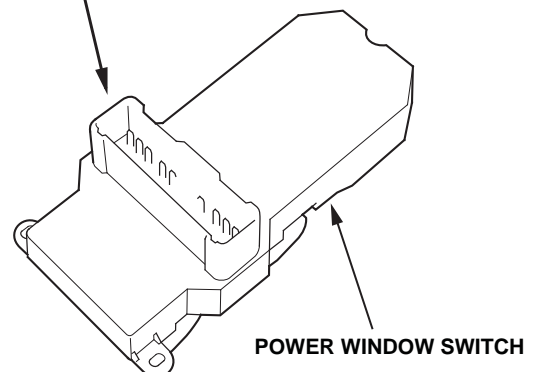
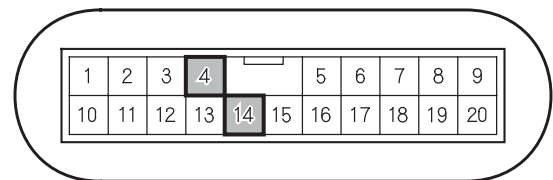

REPAIR PROCEDURE A

NOTE: You must cover all the holes in the power window master switch with the butyl tape and plastic sheet. If the holes are not completely covered, liquid can still enter the switch.

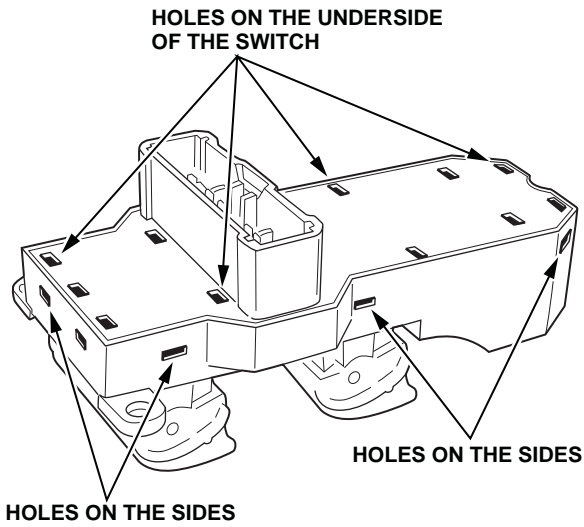

1. Clean the power window switch with a shop towel and rubbing alcohol. Apply the alcohol to the towel, but do not apply alcohol directly to the switch.
2. Affix the butyl tape onto the switch, starting at the connector as shown.

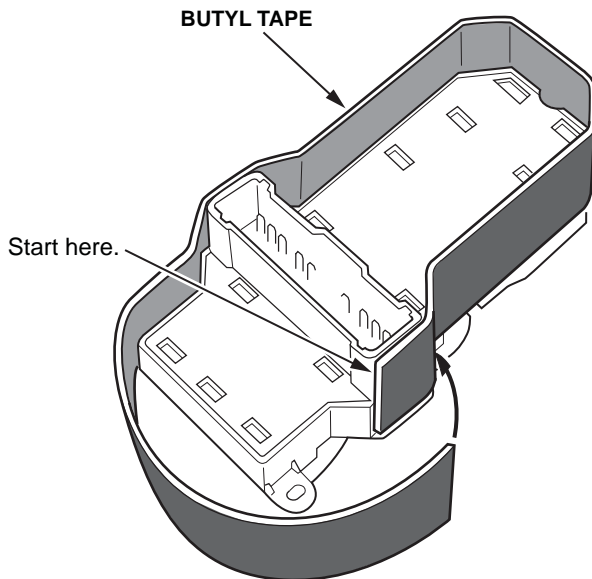

3. Wrap the tape counterclockwise around the entire switch, peeling off the backing sheet as you go.

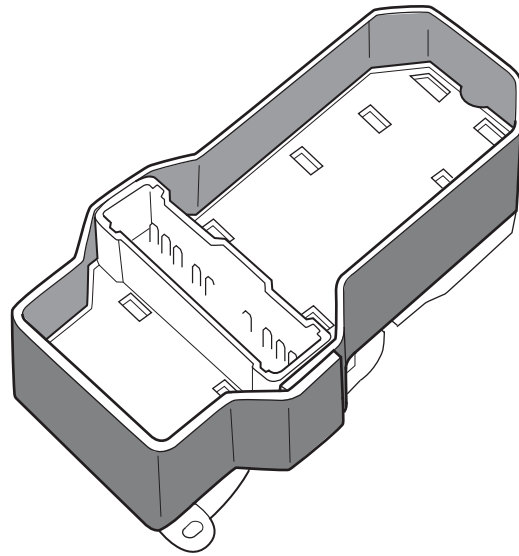

4. Make sure the butyl tape is secure around the corners by pressing it with your fingers.

NOTE: To avoid getting your fingers stuck to the butyl tape, use the removed tape backing to press the butyl tape down.



5. Pinch the butyl tape at the connector so that it sticks properly, with no creases in the butyl tape. Make sure the holes by the connector are covered.

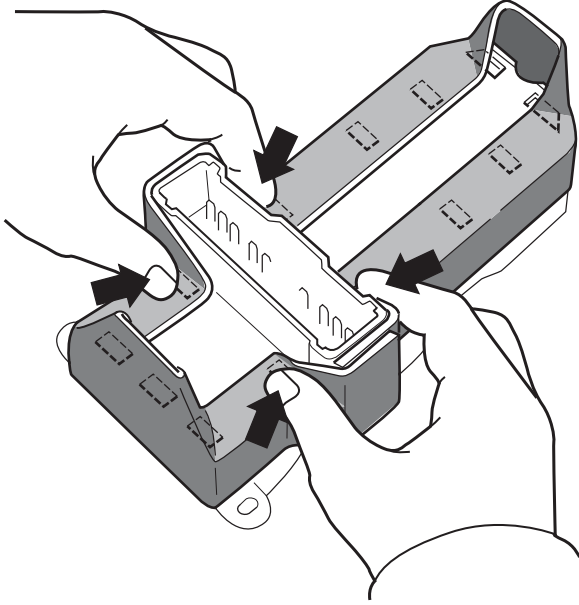

6. Fold the butyl tape over the rear face so that it covers all of the holes.

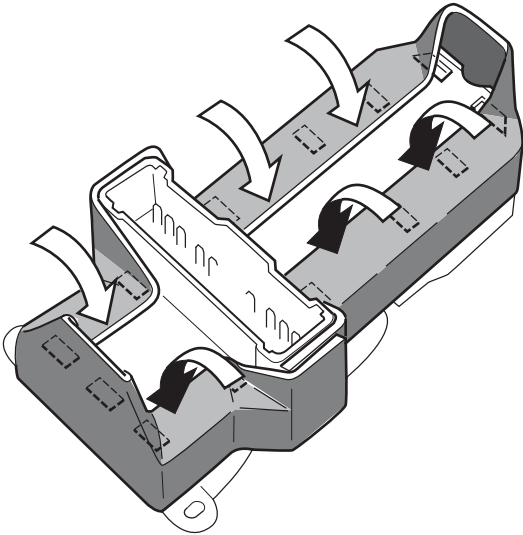

7. Fold the butyl tape at the top and bottom areas of the switch and stick it to the rear face. Make sure the holes are covered.

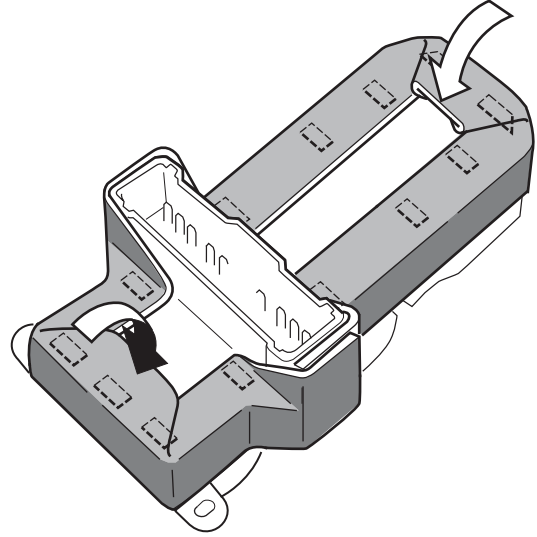

8. Make sure all the butyl tape is secure by pressing it with your fingers. Make sure there are no gaps between the butyl tape and the switch.



NOTE:

- Make sure the butyl tape is properly applied. If the switch was not cleaned, or the butyl tape not properly applied, it may peel and allow liquid to enter the switch.
- If the butyl tape is damaged or creased at any point, remove it, and repeat steps 1 through 8 with a new piece of butyl tape.
- If any of the holes are not completely covered, remove the butyl tape and repeat steps 1 through 8 with a new piece of butyl tape.

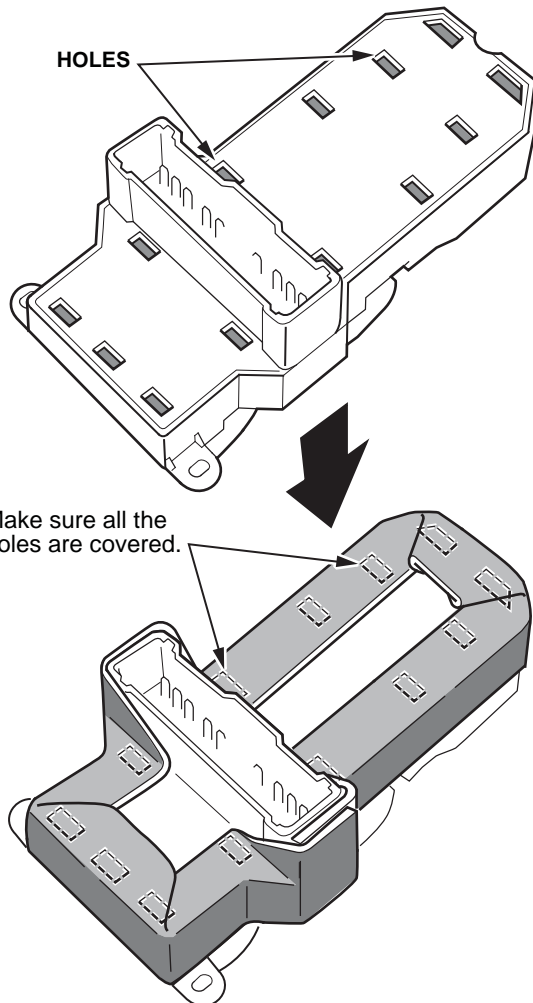

9. Align the tape on the plastic sheet to the starting point of the base of the connector as shown, then apply the plastic sheet.

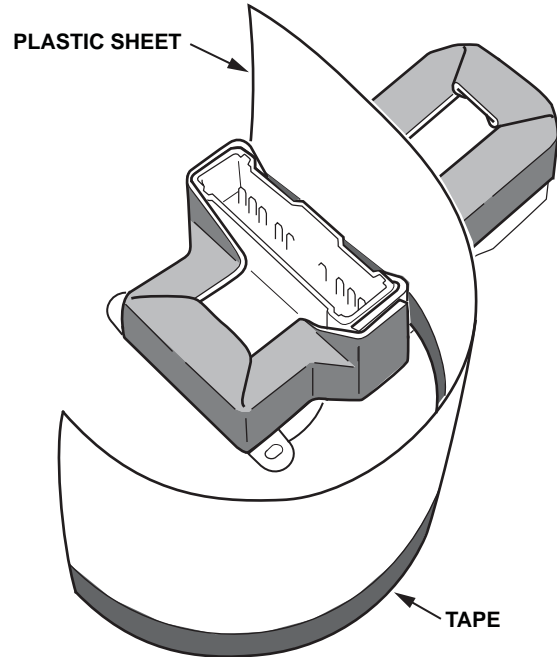

10. Wrap the plastic sheet around the connector, peeling off the backing paper.

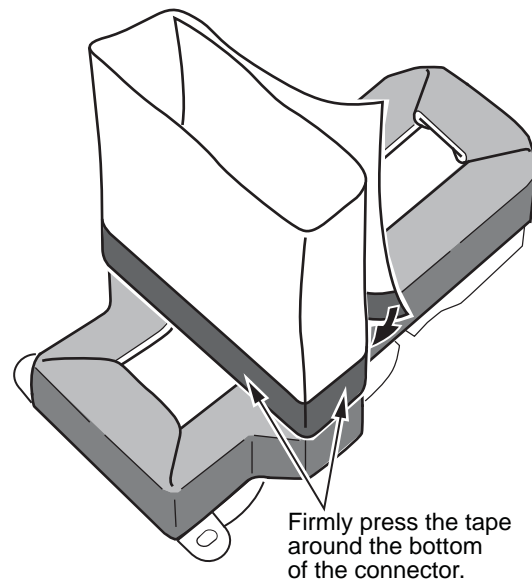

11. Make sure there are no gaps between the tape and the connector by firmly pressing the tape with your finger.

NOTE:

- If you damage the plastic sheet, remove it, and repeat steps 9-10 with a new plastic sheet.
- Make sure the plastic sheet covers the holes at the top and bottom of the connector. If they are not covered, remove the sheet and the butyl tape, and go back to step 1.

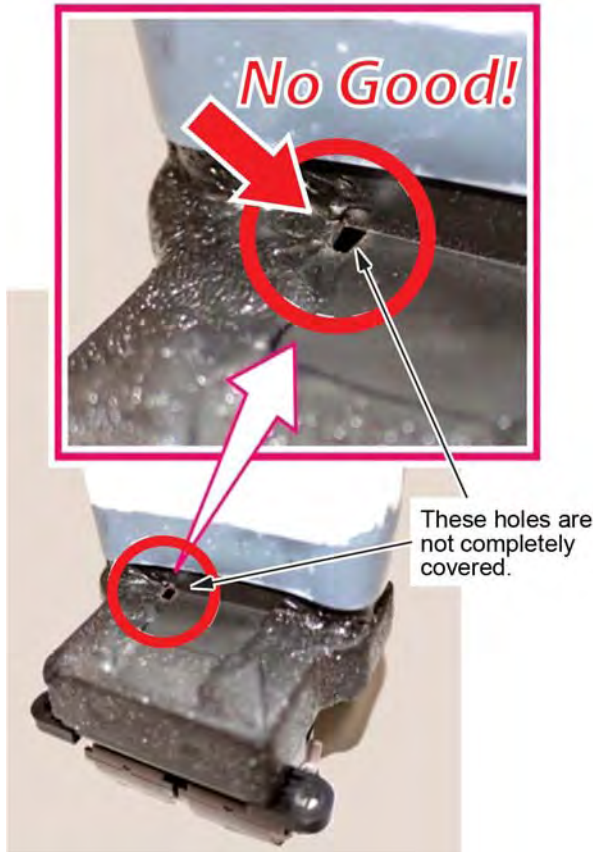

12. Reinstall the driver's switch panel into the door panel. Make sure the plastic sheet is not crushed, crumpled, or folded when you reinstall the switch panel in the door.

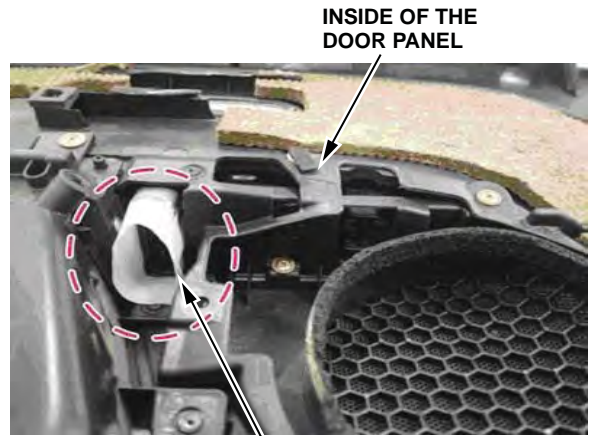

Be sure the plastic sheet on the window switch is not crumpled.

13. Reconnect the connectors.

14. Reinstall the door panel, the mirror mount cover, and the door lock switch.

15. Reset the power window control unit:

- Turn the ignition switch to ON (II).
- Move the driver's window all the way down by holding the driver's window switch firmly down; when the window reaches the bottom, hold the driver's window switch down for 2 seconds.
- Move the driver's window all the way up by holding the driver's window switch firmly up; when the window reaches the top, hold the switch firmly up for 2 seconds.
- If the window does not work in AUTO, turn the ignition switch to LOCK (0) and repeat this entire step.

REPAIR PROCEDURE B

If you need to replace the door wire harness, contact Tech Line first to order the part:

- E-mail photos of the damaged door wire harness connector to techline@ahm.honda.com before calling. (Include the bulletin number 12-067 and the VIN in the subject title of the e-mail.) For more information about taking pictures to send to Tech Line, refer to the ServiceNews article titled *Send Tech Line Your Best Digital Photos*.
- Call Tech Line. Tech Line will determine if you need to replace the door wire harness based on the photos. If a replacement is approved, Tech Line will release one from stock to be sent to your dealership.

1. Replace the driver's door harness.

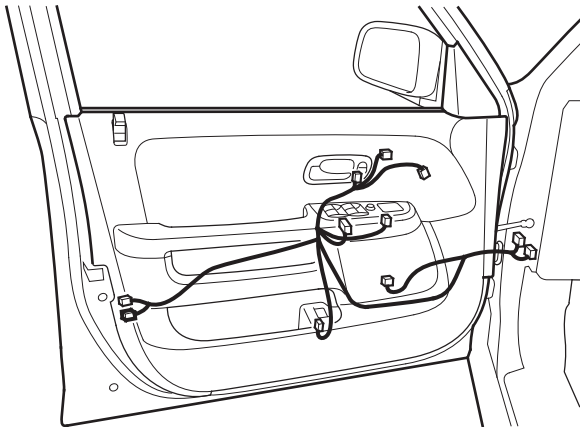

2. Reconnect the connectors.
3. Replace the power window master switch.
4. Reinstall the driver's switch panel into the door panel.
5. Reinstall the door panel.
6. Reset the power window control unit:
 - Turn the ignition switch to ON (II).
 - Move the driver's window all the way down by holding the driver's window switch firmly down; when the window reaches the bottom, hold the driver's window switch down for 2 seconds.
 - Move the driver's window all the way up by holding the driver's window switch firmly up; when the window reaches the top, hold the switch firmly up for 2 seconds.
 - If the window does not work in AUTO, turn the ignition switch to LOCK (0) and repeat this entire step.

Example of Customer Letter

November 2012

Safety Recall: 2002–06 CR-V Driver's Power Window Switch Does Not Work or Works Intermittently - NHTSA Recall 12V-486

Dear Honda CR-V Owner:

This notice is sent to you in accordance with the requirements of the National Traffic and Motor Vehicle Safety Act.

What is the reason for this notice?

Honda has decided that a defect which relates to motor vehicle safety exists in certain 2002–2006 model year CR-V vehicles. There is a potential failure of the power window master switch which may cause the switch to heat up, resulting in the switch melting, failing to work, producing smoke or burning. The possibility of fire is a potential safety risk. A switch failure, and a fire, could occur even if the vehicle is not in use. As a precaution, owners are advised to park outside until the recall repair has been performed.

What should you do?

Call any authorized Honda dealer and make an appointment to have your vehicle repaired, at **no cost to you**. The dealer will repair or replace the power window master switch assembly. The repair process may take anywhere from between 18 minutes to 48 minutes; however, your vehicle will need to be at the dealer for a longer period of time. We recommend that you plan to leave your vehicle for half a day to allow the dealer flexibility in scheduling.

Who to contact if you experience problems

If you are not satisfied with the service you receive from your Honda dealer, you may write to:

American Honda Motor Co., Inc.
Honda Automobile Customer Service
Mail Stop 500-2N-7A
1919 Torrance Blvd.
Torrance, CA 90501-2746

If you believe that American Honda or the dealer has failed or is unable to remedy the defect in your vehicle, without charge, within a reasonable period of time (60 days from the date you first contact the dealer for a repair appointment), you may submit a complaint to:

Administrator
National Highway Traffic Safety Administration
1200 New Jersey Ave., SE
Washington, DC 20590

Or call the toll-free Safety Hotline at 888-327-4236 (TTY 800-424-9153), or go to <http://www.safercar.gov>.

What to do if you feel this notice is in error

Registration records indicate that you are the current owner or lessee of a 2002–2006 CR-V involved in this campaign. If this is not the case, or the name/address information is not correct, please complete and sign the Information Change Card and return it in the enclosed postage-paid envelope. We will then update our records.

What if you already had your vehicle repaired for this issue

If you previously paid to have the power window switch replaced, you may be eligible for reimbursement. Refer to the attached Instructions for Reimbursement for the eligibility requirements and the reimbursement procedure.

Lessor Information

Federal law requires that any vehicle lessor receiving this recall notice must forward a copy of this notice to the lessee within 10 days.

If you have questions

If you have any questions about this notice, or need assistance with locating a Honda dealer, please call Honda Automobile Customer Service at 1-800-999-1009, and select option 4. U.S. customers can also locate a dealer online at *Hondacars.com*. Customers in U.S. territories, please contact your local dealer/distributor.

We apologize for any inconvenience this campaign may cause you.

Sincerely,

American Honda Motor Co., Inc.
Honda Automobile Division