

# Installation Instructions and Guidelines

Mako 18LTS trailer capacity upgrade

# Table of Contents

---

▶ General overview	3
▶ Required components	4
▶ Cautionary statements	5
▶ Procedure for trailer currently fitted with brakes	6
▶ Procedure for trailer requiring brake installation	16
▶ Procedure for trailer with no brakes	47
▶ Brake bleeding procedure	53

# Overview

---

- ❑ Some Mako 18 LTS boats sold with EZ Loader trailers may be slightly heavier than the carrying capacity of the trailer
- ❑ Retrofit of EZ Loader trailer to increase carrying capacity will be completed where this condition exists
- ❑ Retrofit increases carrying capacity to 2700#
- ❑ Retrofit increases Gross Vehicle Weight Rating (GVWR) to 3420#
- ❑ Retrofit may require addition of brakes (if not equipped) in some states due to increased GVWR
- ❑ This document provides retrofit requirements and instructions

# Required Components and Guidelines

---

- ❑ New axle with higher carrying capacity rating
- ❑ New tires and wheels with higher carrying capacity rating (includes spare if so equipped)
- ❑ Brakes may be required
  - ❑ Installation of higher carrying capacity components will increase carrying capacity and increase the GVWR of the trailer
  - ❑ Increase of GVWR may exceed weight threshold of some state laws and require installation of brakes if not already equipped. It is your responsibility to know and abide by your state laws.
- ❑ Amended carrying capacity, GVWR label and tire loading information label
  - ❑ Amended capacity, GVWR, and tire loading information label must be installed adjacent to existing labels
  - ❑ Existing VIN and tire loading information labels must not be removed, defaced, or covered up.

# General Retrofit Instructions

---

- ❑ Wear appropriate personal safety protection when performing retrofit installation

## Caution:

For safety reasons it is recommended that boat is removed from trailer prior to performing retrofit installation

## Retrofit Instructions

---

**Trailer with brakes  
currently installed**

# Retrofit Instructions for Trailers With Brakes Already Installed

---

- ❑ Install brake lines, brake line tee, and hoses on new axle using tie straps provided as shown in following pictures.



# Retrofit Instructions for Trailers With Brakes Already Installed

---

- ❑ Install left brake hoses on axle as shown in picture.

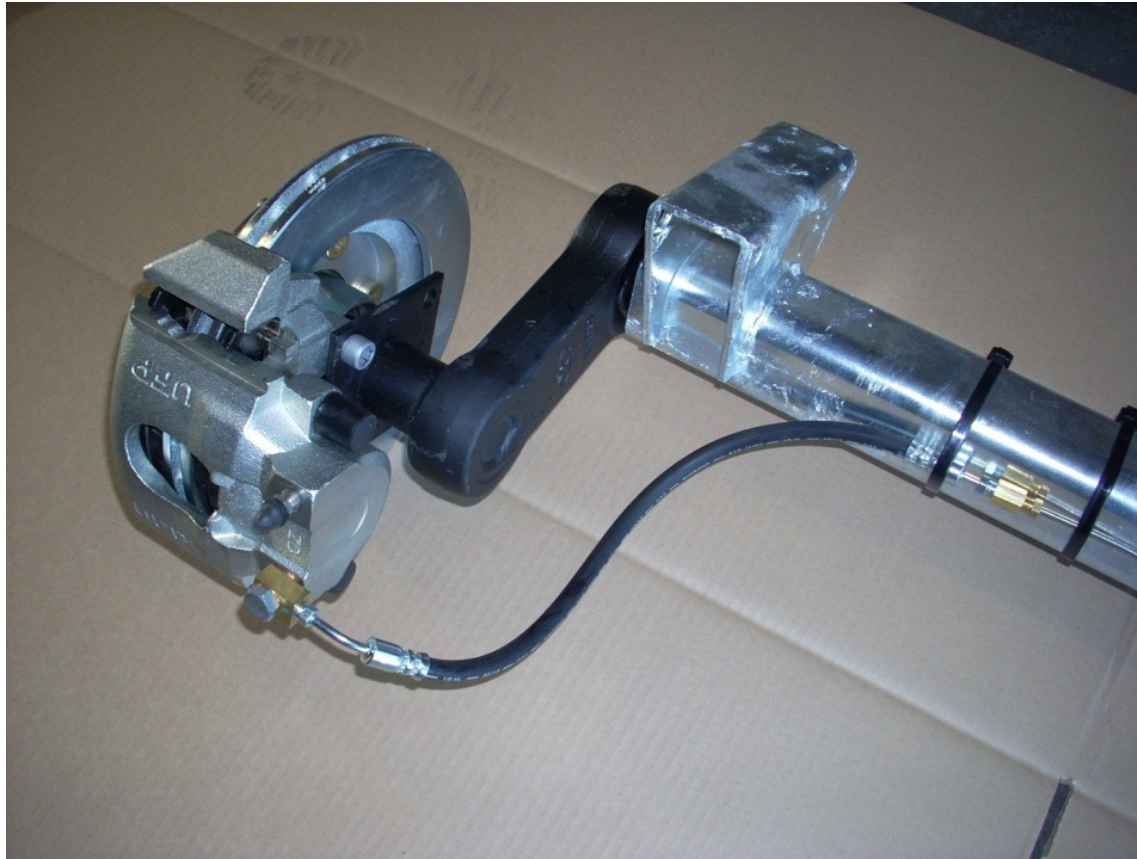

# Retrofit Instructions for Trailers With Brakes Already Installed

---

- ❑ Install right brake hoses on axle as shown in picture
  - ❑ Install supplied copper washer in tee where brake hose and steel brake line connect
  - ❑ Top washer for trailer brake line installed later in procedure

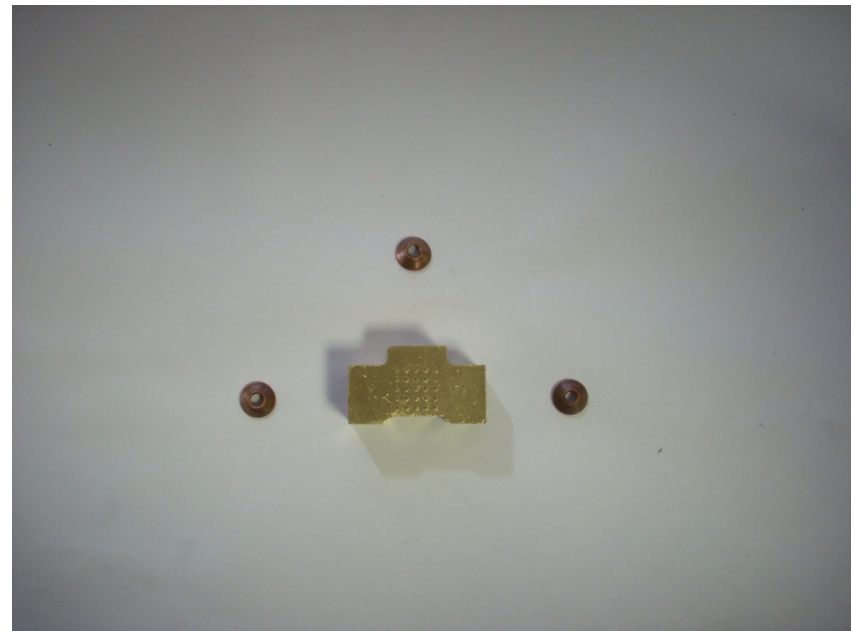
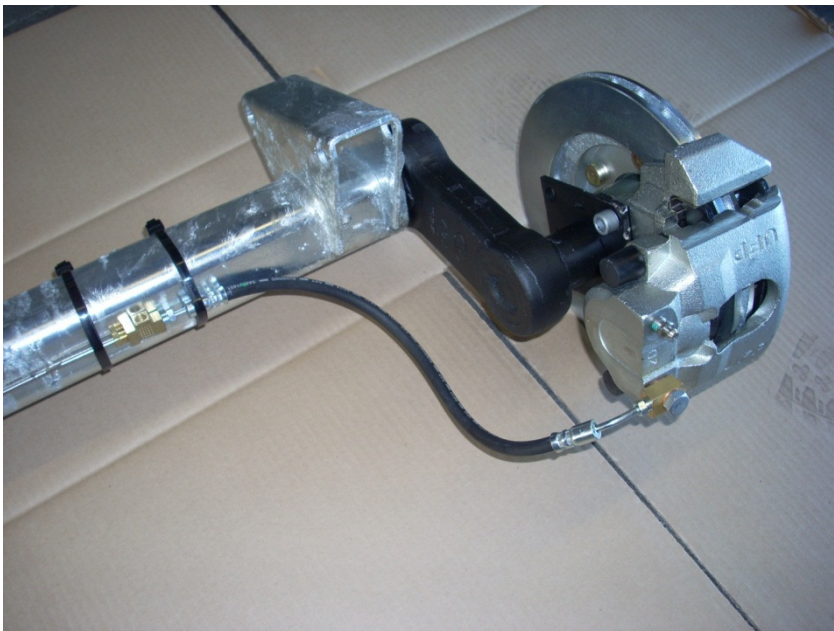

# Retrofit Instructions for Trailers With Brakes Already Installed

---

- ❑ **NOTE: Fasteners on trailer are stainless steel.**
  - ❑ New fasteners will be supplied for all retrofit installations
    - ❑ Axle bolts and nuts
    - ❑ Actuator bolts and nuts
  - ❑ If using air drive tools to remove and re-install fasteners, speed must be reduced or fasteners will be subject to seizing
  - ❑ Anti seize compound must be used when re-installing fasteners

# Retrofit Instructions for Trailers With Brakes Already Installed

---

- ❑ Have small container and rags available to capture brake fluid
- ❑ Disconnect brake line from tee on axle
- ❑ Remove nuts from bolts that attach axle to axle mounting hanger (note mounting holes used to mount axle. The same holes will be used to mount new axle)



# Retrofit Instructions for Trailers With Brakes Already Installed

---

- ❑ Jack up trailer and place jack stand under frame just behind chassis mounting on both sides
- ❑ Support axle in center with floor jack
- ❑ Remove bolts that secure axle to mounting hanger
- ❑ Slowly lower floor jack and remove axle from trailer
- ❑ Install new axle, inserting bolts in the same mounting holes as the axle that was removed
- ❑ Torque bolts to 70 lbs/ft

# Retrofit Instructions for Trailers With Brakes Already Installed

---

- ❑ Install new ST185/80D13D tire and wheel on both sides of trailer
- ❑ Jack up trailer, remove jack stands and return trailer to ground on both sides
- ❑ Torque lug nuts to 80 lbs/ft using a crisscross pattern as shown in diagram

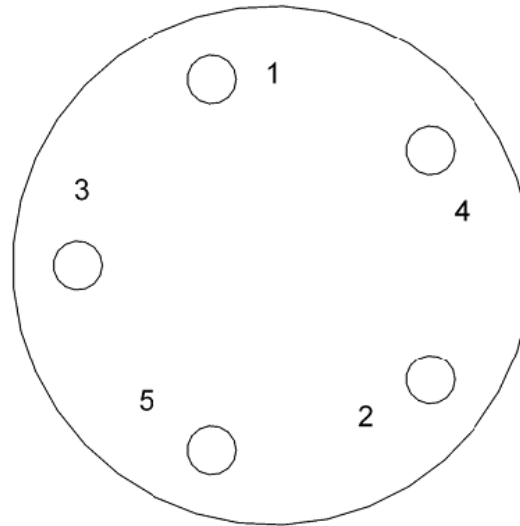

# Retrofit Instructions for Trailers With Brakes Already Installed

---

- ❑ Reconnect main brake line to tee on axle
  - ❑ Install supplied copper washer in brake tee before attaching main brake line



- ❑ Bleed brakes following brake bleeding procedure included with these instructions

# Retrofit Instructions for Trailers With Brakes Already Installed

- ❑ Replace spare tire and wheel ST175/80R13C with new ST185/80D13D tire and wheel if trailer is so equipped
- ❑ Install amended capacity and GVWR label
  - ❑ Do not remove, deface, or cover up existing labels
  - ❑ Place new labels adjacent to existing labels

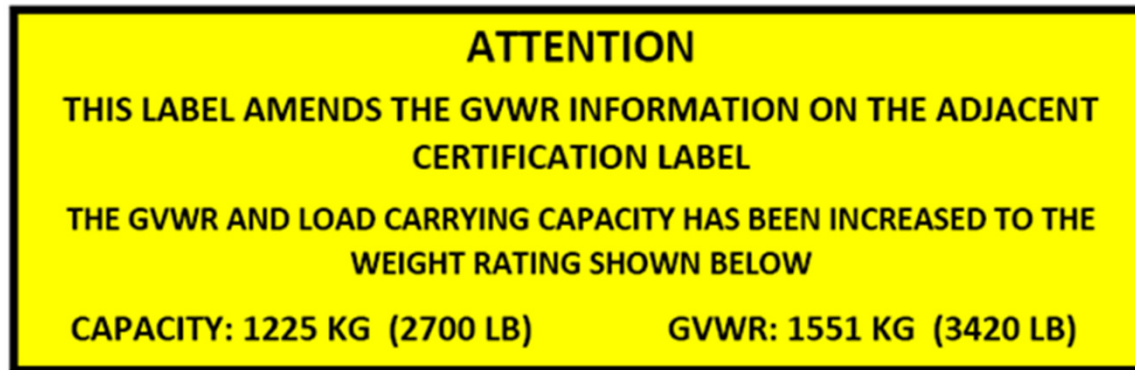

- ❑ Install new tire loading label
- ❑ Retrofit installation is complete

## Retrofit Instructions

---

**Trailer requiring  
brake installation**

# Retrofit Instructions for Trailers That Require the Addition of Brakes

---

- ❑ Install brake lines, brake line tee, and hoses on new axle using tie straps provided as shown in following pictures.



# Retrofit Instructions for Trailers That Require the Addition of Brakes

---

- ❑ Install left brake hoses on axle as shown in picture.

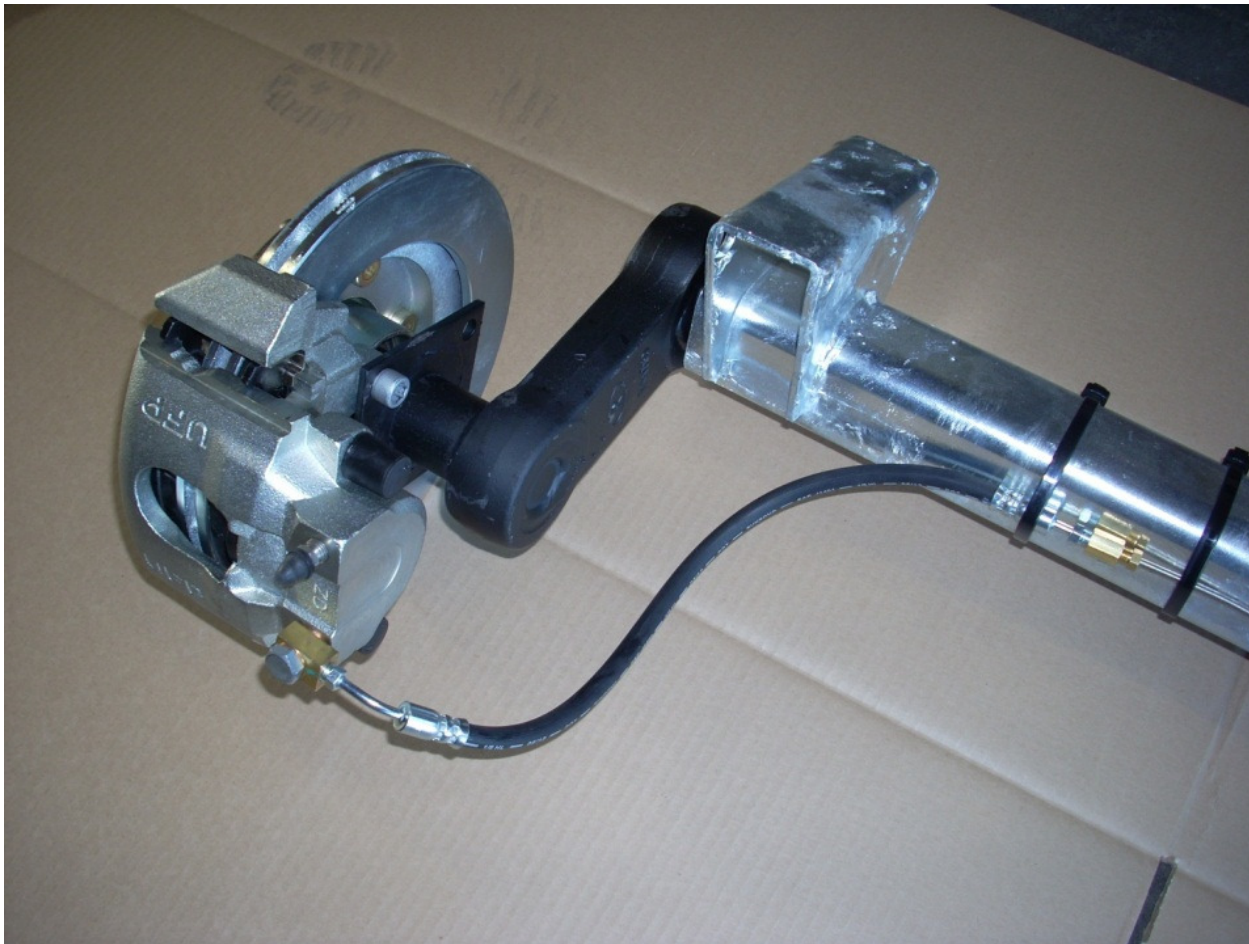

# Retrofit Instructions for Trailers That Require the Addition of Brakes

---

- ❑ Install right brake hoses on axle as shown in picture
  - ❑ Install copper washer in tee where brake hose and steel brake line connect
  - ❑ Top washer for trailer brake line installed later in procedure

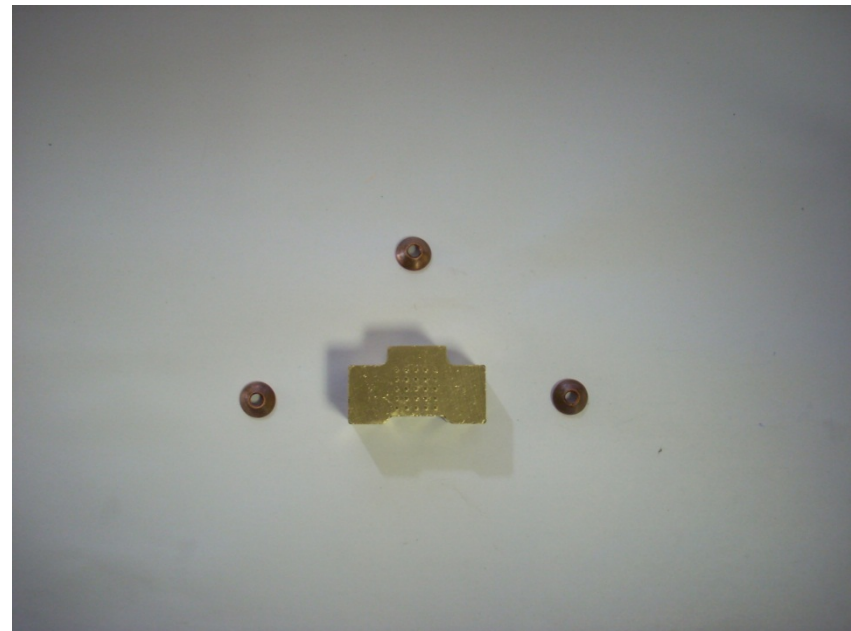
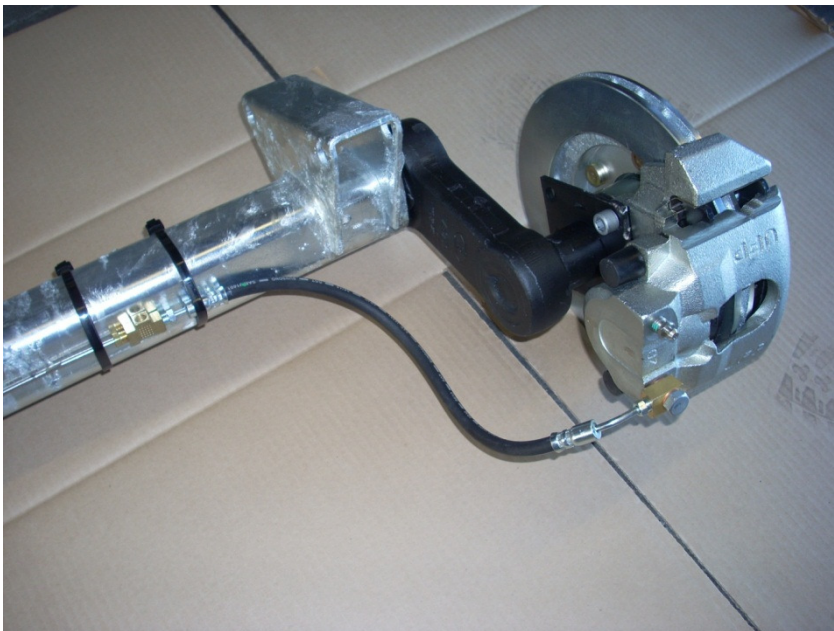

# Retrofit Instructions for Trailers That Require the Addition of Brakes

---

- ❑ **NOTE: Fasteners on trailer are stainless steel.**
  - ❑ New fasteners will be supplied for all retrofit installations
    - ❑ Axle bolts and nuts
    - ❑ Actuator bolts and nuts
  - ❑ If using air drive tools to remove and re-install fasteners, speed must be reduced or fasteners will be subject to seizing
  - ❑ Anti seize compound must be used when re-installing fasteners

# Retrofit Instructions for Trailers That Require the Addition of Brakes

---

- ❑ Remove bolts that attach axle to axle mounting hanger (note mounting holes used to mount axle. The same holes will be used to mount new axle)



# Retrofit Instructions for Trailers That Require the Addition of Brakes

---

- ❑ Jack up trailer and place jack stand under frame just behind chassis mounting on both sides
- ❑ Support axle in center with floor jack
- ❑ Remove bolts that secure axle to mounting hanger
- ❑ Slowly lower floor jack and remove axle from trailer
- ❑ Install new axle, inserting bolts in the same mounting holes as the axle that was removed
- ❑ Torque bolts to 70 lbs/ft



# Retrofit Instructions for Trailers That Require the Addition of Brakes

---

- ❑ Install new ST185/80D13D tire and wheel on both sides of trailer
- ❑ Jack up trailer, remove jack stands and return trailer to ground on both sides
- ❑ Torque lug nuts to 80 lbs/ft using a crisscross pattern as shown in diagram

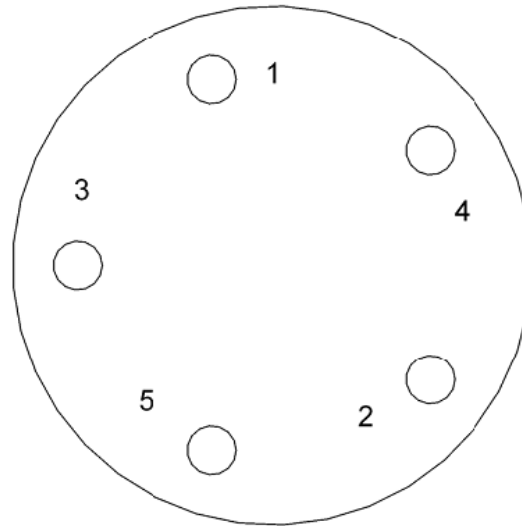

# Retrofit Instructions for Trailers That Require the Addition of Brakes

---

- ❑ Remove the three bolts that attach the coupler to the trailer tongue and remove coupler

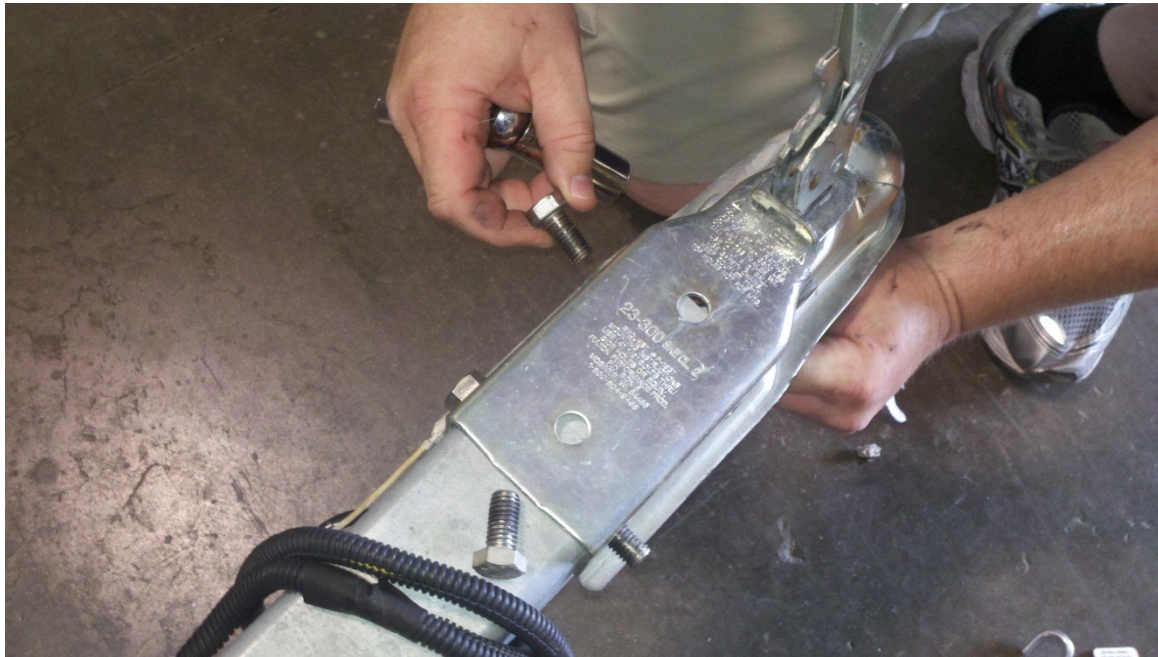

# Retrofit Instructions for Trailers That Require the Addition of Brakes

---

- ❑ Drill a 5/16" diameter hole in the left side of the tongue 1/2" from the end and 1" up from the bottom as shown.
- ❑ Touch up hole with silver paint

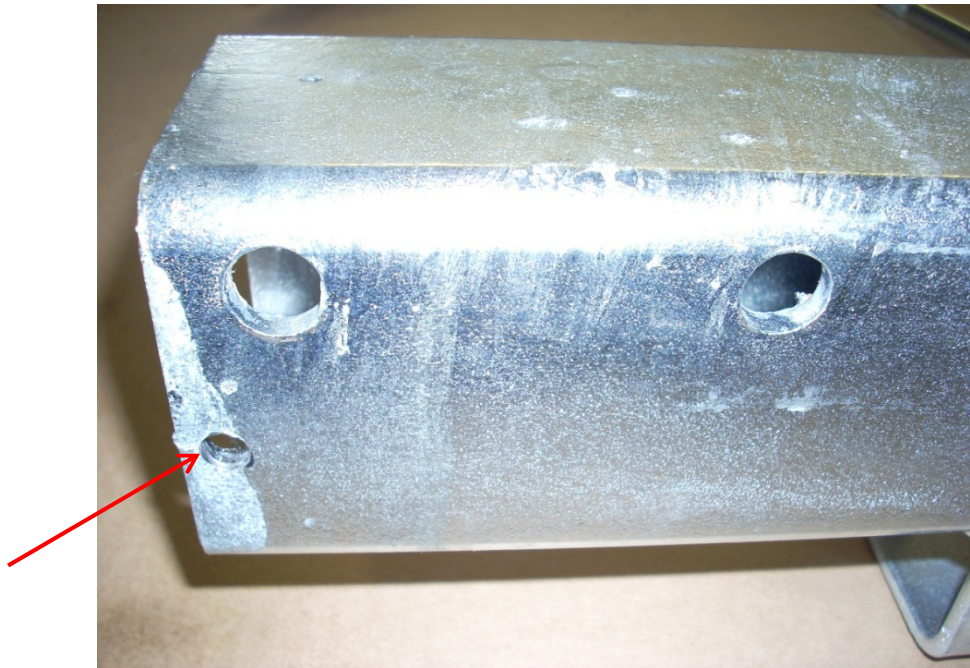

## Retrofit Instructions for Trailers That Require the Addition of Brakes

---

- ❑ Remove wire loom from wire harness and grommet from front left side of tongue where wire loom exits tongue to the tow vehicle

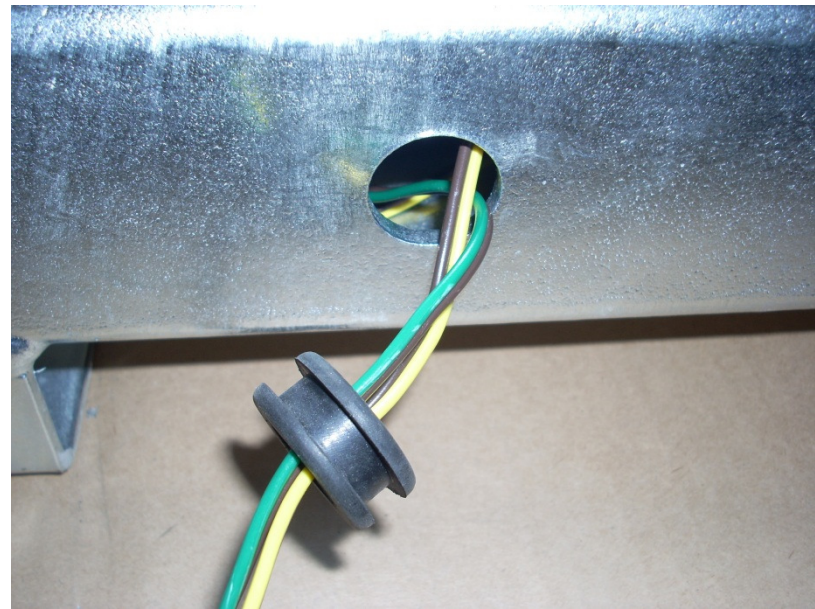

## Retrofit Instructions for Trailers That Require the Addition of Brakes

---

- ❑ Install hydraulic disc actuator using two 1/2x4 1/2” bolts as shown. do not install nuts on actuator mounting bolts at this time
- ❑ Open swing tongue to approximately 90 degrees

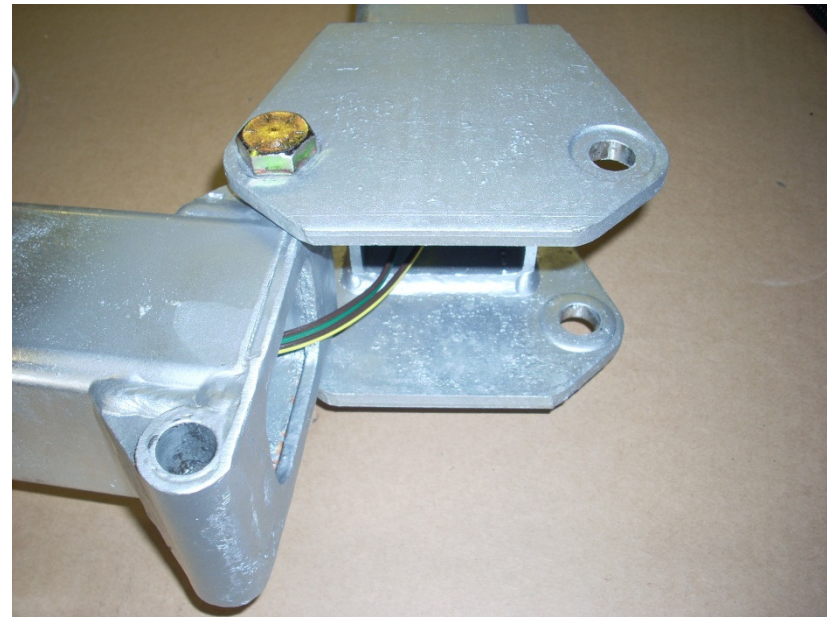
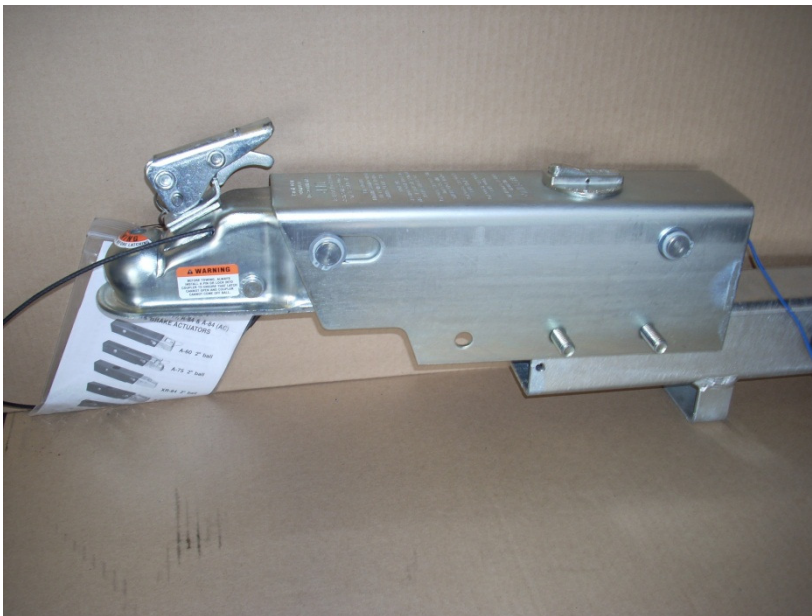

## Retrofit Instructions for Trailers That Require the Addition of Brakes

---

- ❑ Remove steel clips that hold wire loom to inside of frame on the right side of the trailer from the axle forward

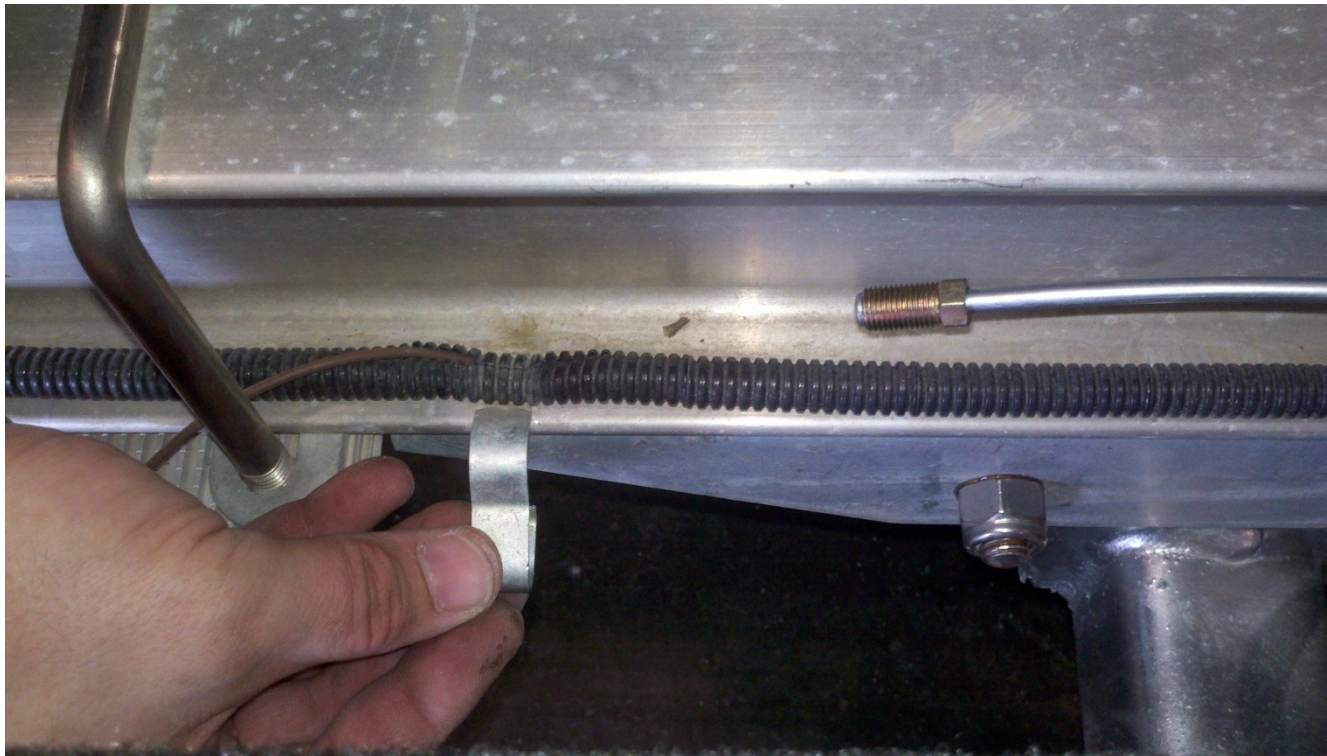

# Retrofit Instructions for Trailers That Require the Addition of Brakes

---

- ❑ Install main brake line starting at the rear of the trailer on the right side and feed brake line forward as you uncoil.
- ❑ Route the brake line behind the forward cross member mounting brackets

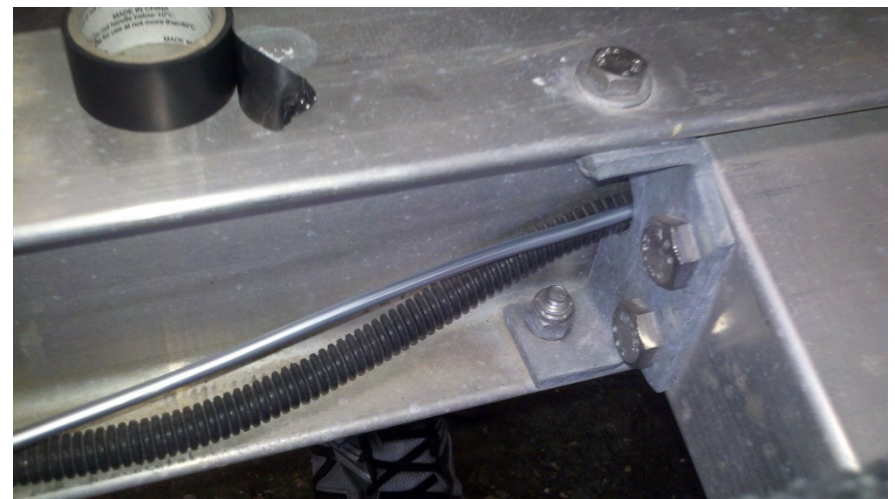

## Retrofit Instructions for Trailers That Require the Addition of Brakes

---

- ❑ Before routing brake line through channel cross member at front of trailer, install supplied grommet and wrap a small piece off electrical tape around the brake line to prevent the fitting from sliding rearward.
- ❑ Proceed installing brake line through hole in channel cross member



## Retrofit Instructions for Trailers That Require the Addition of Brakes

---

- ❑ Remove grommet from right side of tongue where wire loom passes into tongue
- ❑ Route brake line through grommet



## Retrofit Instructions for Trailers That Require the Addition of Brakes

---

- ❑ Continue routing brake line by inserting into the same hole in the side of the tongue that the wire loom exits
- ❑ Re-insert grommet in side of tongue



# Retrofit Instructions for Trailers That Require the Addition of Brakes

---

- ❑ Push line forward until it extends just past the joint in the swing tongue

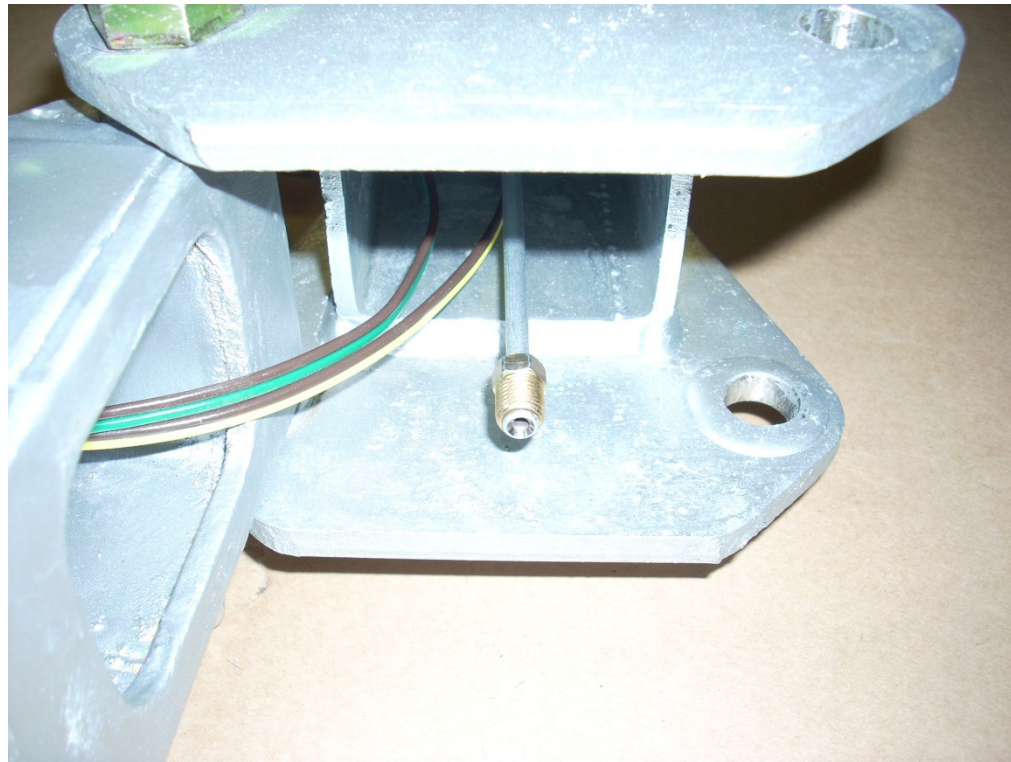

## Retrofit Instructions for Trailers That Require the Addition of Brakes

---

- ❑ Insert female end of 24" male/female brake hose into hole where wire exits front half of swing tongue and feed toward hinge
- ❑ Insert 12" brake line through grommet and connect to brake hose with supplied union

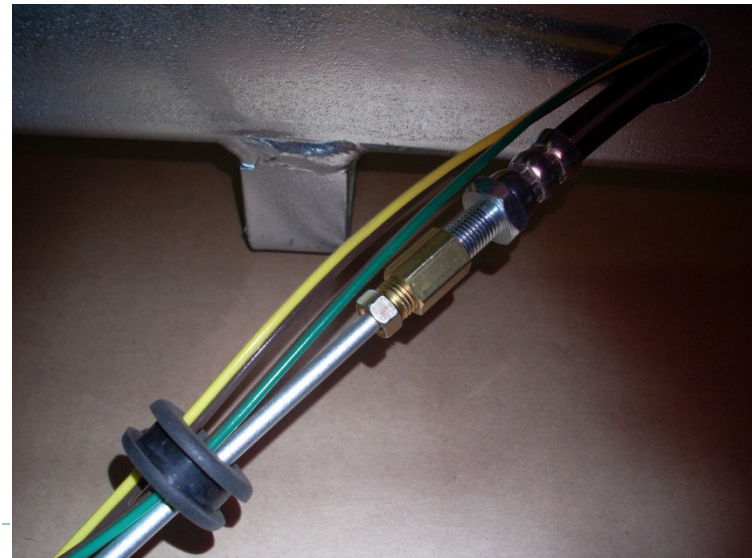
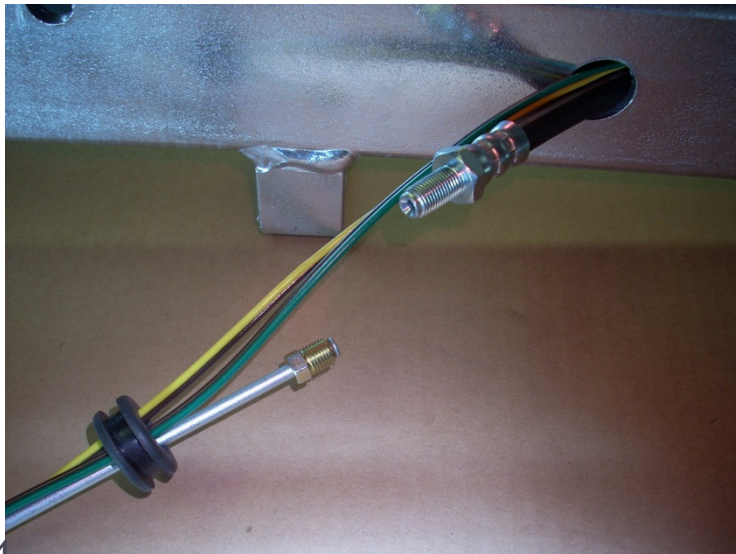

# Retrofit Instructions for Trailers That Require the Addition of Brakes

---

- ❑ Carefully bend the front of the brake line in a large curving arc as shown. Be careful not to crimp or collapse the brake line.
- ❑ Push fittings where tube connects to hose inside of tongue and connect tube to the solenoid on the back of the actuator

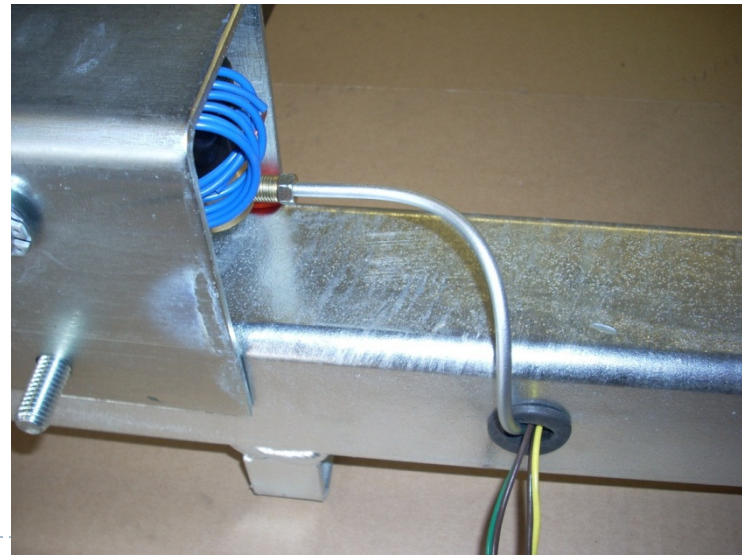

## Retrofit Instructions for Trailers That Require the Addition of Brakes

---

- ❑ Connect rear end of brake hose to trailer brake line
- ❑ Push brake line rearward into trailer so that brake hose is approximately centered in tube as shown

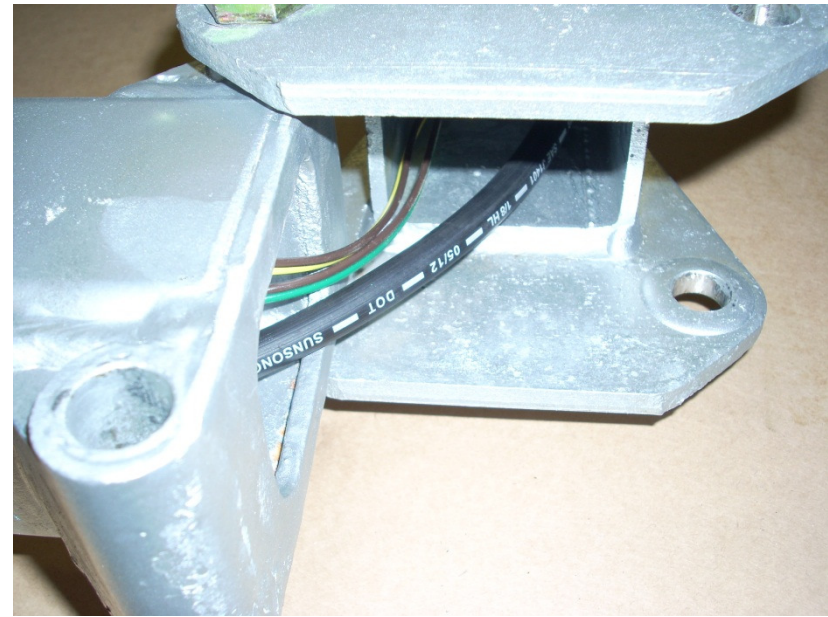
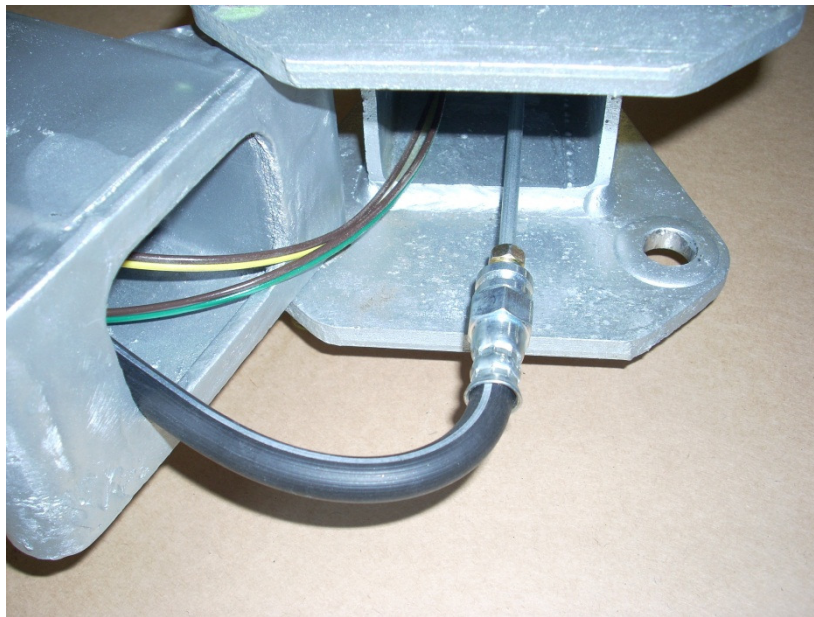

# Retrofit Instructions for Trailers That Require the Addition of Brakes

---

- ❑ Install wire loom on 5 way harness adapter as shown
  - ❑ Slide wire loom over wires and trim excess loom
  - ❑ Wrap loom with electrical tape at each end and then at approximately 8 inches intervals between ends



# Retrofit Instructions for Trailers That Require the Addition of Brakes

---

- ❑ Connect 4 pin end of 5 way harness into existing trailer wire harness
- ❑ Connect 2 pin end of 5 way harness into supplied 2 pin loose wire harness
- ❑ Attach 5 way harness to 5/16" hole drilled previously in side of tongue with supplied clamp and 1/4 x 1" bolt

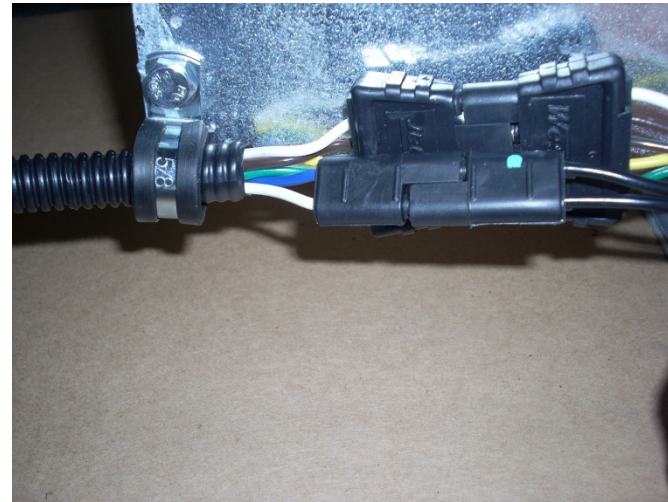
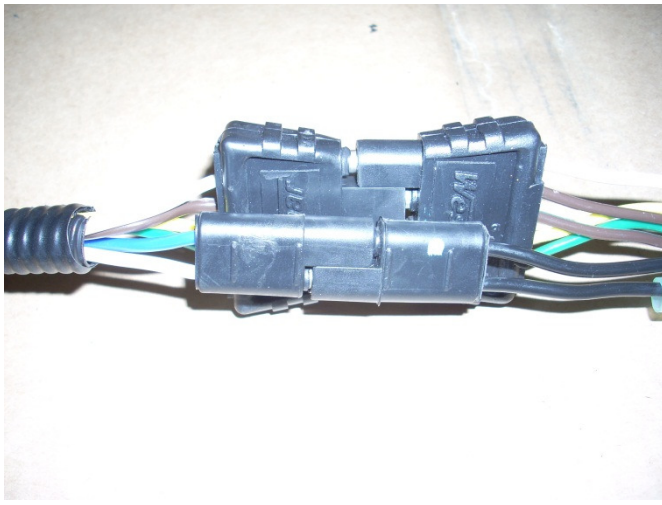

# Retrofit Instructions for Trailers That Require the Addition of Brakes

---

- ❑ Cut the ground wires on the trailer harness and the solenoid harness to appropriate length
- ❑ Install supplied ring terminals on ground wires and attach to coupler bolt as shown
- ❑ **WARNING: Ensure that the ground wire (white wire) from the 2 pin plug on the 5 way harness is connected to the ground wire on the solenoid plug**

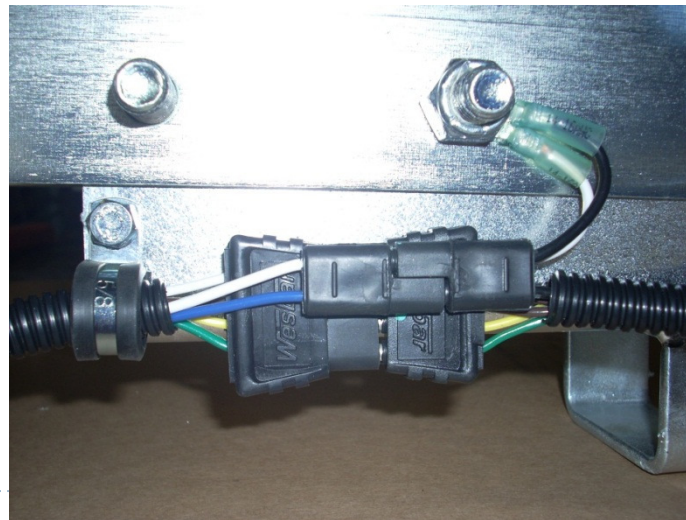

# Retrofit Instructions for Trailers That Require the Addition of Brakes

---

- ❑ Install remaining nut on actuator mounting bolt and torque both bolts to 50 lbs/ft

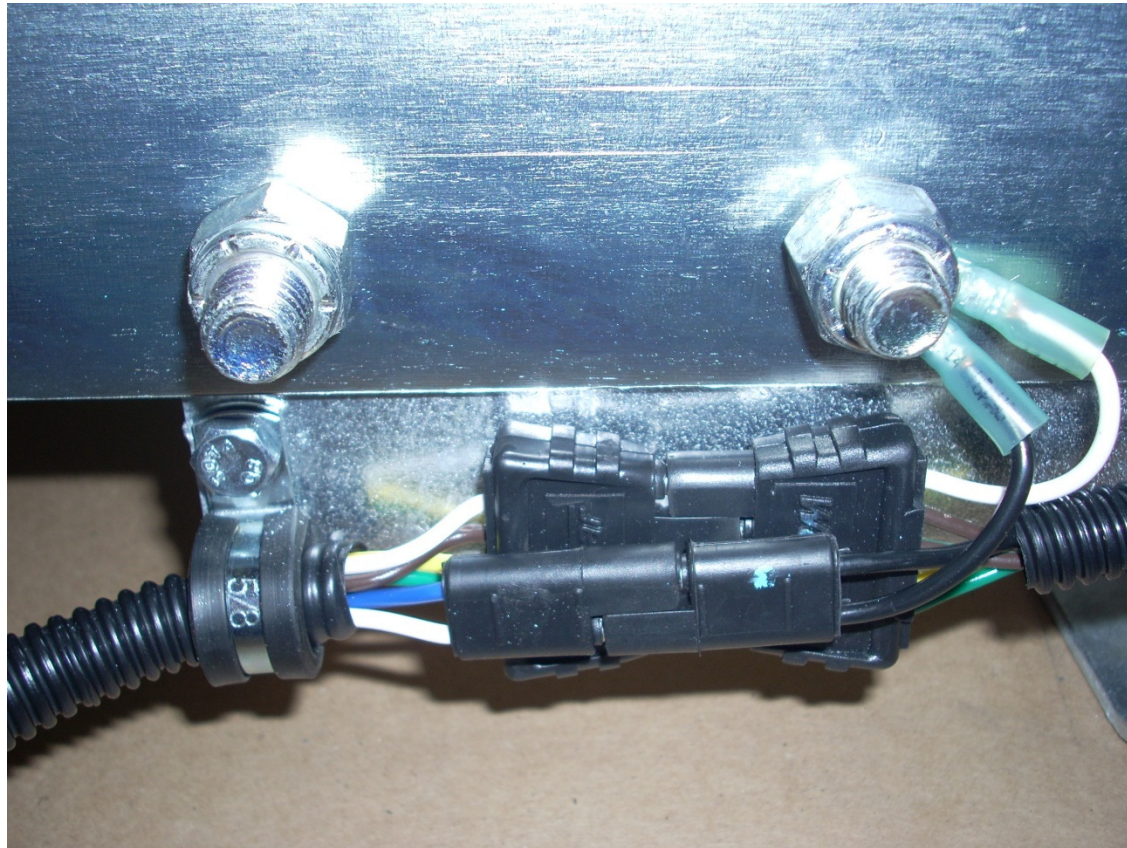

# Retrofit Instructions for Trailers That Require the Addition of Brakes

---

- ❑ Cut blue solenoid wire and 2 pin solenoid wire plug to the appropriate length and connect with supplied heat shrink butt connector. Shrink with heat gun
- ❑ Install approximately 10” of wire loom on the trailer harness and tape one end

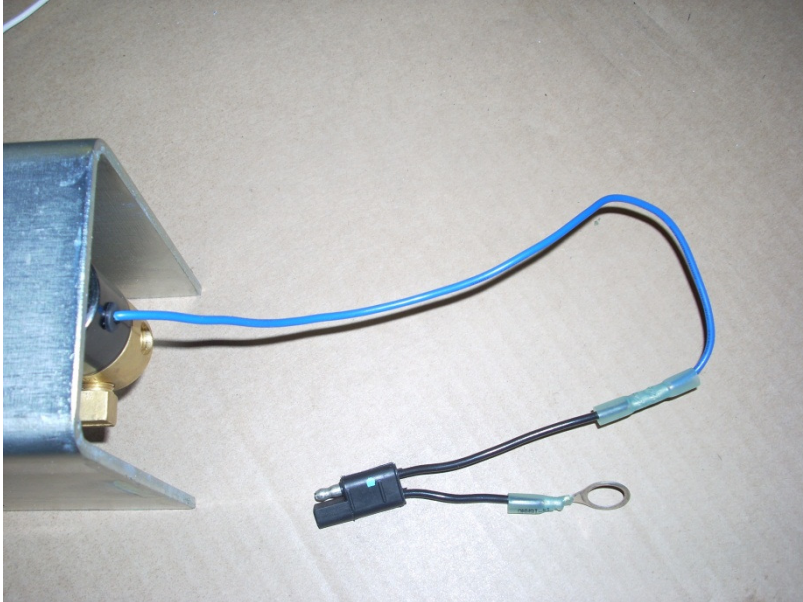

# Retrofit Instructions for Trailers That Require the Addition of Brakes

---

- ❑ Slide wire loom through grommet and into side of tongue
- ❑ Insert wires into wire loom and tape opposite end and middle

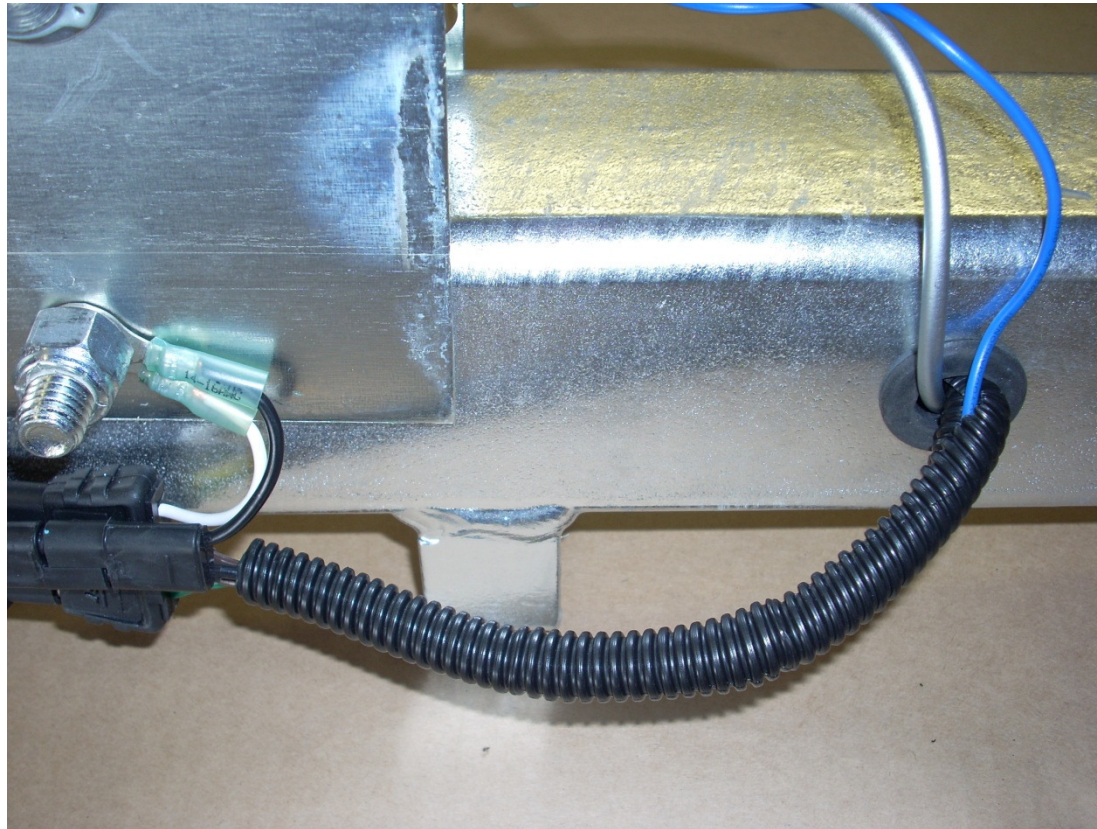

# Retrofit Instructions for Trailers That Require the Addition of Brakes

---

- ❑ Completed installation should appear as shown



# Retrofit Instructions for Trailers That Require the Addition of Brakes

---

- ❑ Coil any excess remaining brake line at the rear and attach to tee on axle
- ❑ Install supplied copper washer in brake line tee before attaching brake line to axle

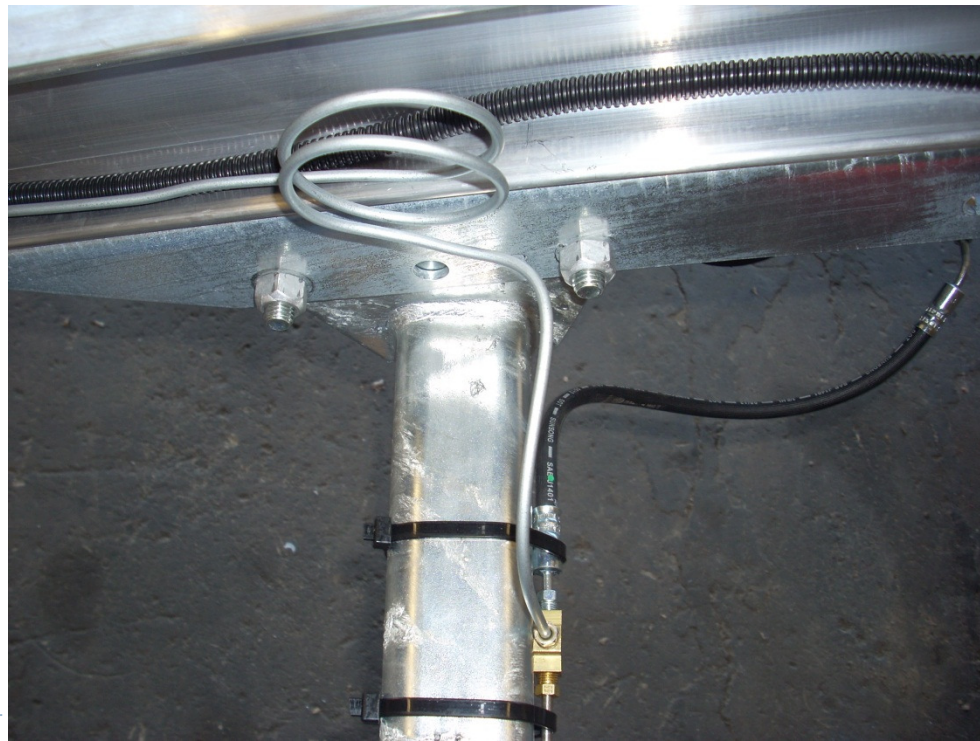

# Retrofit Instructions for Trailers That Require the Addition of Brakes

- ❑ Install supplied new metal clips over wire loom and brake line



# Retrofit Instructions for Trailers With Brakes Already Installed

- ❑ Replace spare tire and wheel ST175/80R13C with new ST185/80D13D tire and wheel if trailer is so equipped
- ❑ Install amended capacity and GVWR label
  - ❑ Do not remove, deface, or cover up existing labels
  - ❑ Place new labels adjacent to existing labels



- ❑ Install new tire loading label
- ❑ Retrofit installation is complete

## Retrofit Instructions

---

**Trailer with no brake  
requirement**

# Retrofit Instructions For Trailers That Do Not Require Brakes

---

- ❑ **NOTE: Fasteners on trailer are stainless steel.**
  - ❑ New fasteners will be supplied for all retrofit installations
    - ❑ Axle bolts and nuts
    - ❑ Actuator bolts and nuts
  - ❑ If using air drive tools to remove and re-install fasteners, speed must be reduced or fasteners will be subject to seizing
  - ❑ Anti seize compound must be used when re-installing fasteners

# Retrofit Instructions For Trailers That Do Not Require Brakes

---

- ❑ Remove nuts from bolts that attach axle to axle mounting hanger (note mounting holes used to mount axle. The same holes will be used to mount new axle)



# Retrofit Instructions For Trailers That Do Not Require Brakes

---

- ❑ Jack up trailer and place jack stand under frame just behind chassis mounting on both sides
- ❑ Support axle in center with floor jack
- ❑ Remove bolts that secure axle to mounting hanger
- ❑ Slowly lower floor jack and remove axle from trailer
- ❑ Install new axle, inserting bolts in the same mounting holes as the axle that was removed
- ❑ Torque bolts to 70 lbs/ft

# Retrofit Instructions For Trailers That Do Not Require Brakes

---

- ❑ Install new ST185/80D13D tire and wheel on both sides of trailer
- ❑ Jack up trailer, remove jack stands and return trailer to ground on both sides
- ❑ Torque lug nuts to 80 lbs/ft using a crisscross pattern as shown in diagram

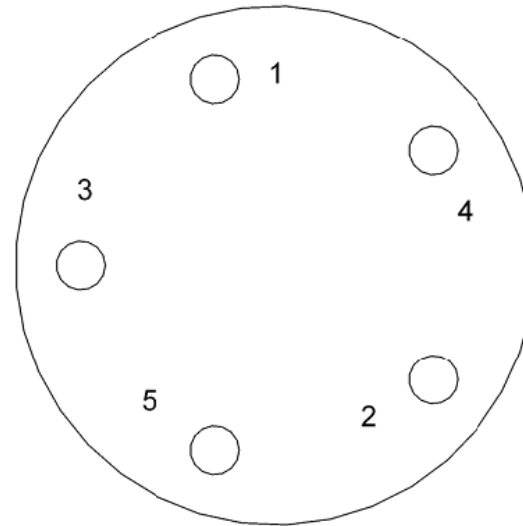

# Retrofit Instructions for Trailers With Brakes Already Installed

- ❑ Replace spare tire and wheel ST175/80R13C with new ST185/80D13D tire and wheel if trailer is so equipped
- ❑ Install amended capacity and GVWR label
  - ❑ Do not remove, deface, or cover up existing labels
  - ❑ Place new labels adjacent to existing labels



- ❑ Install new tire loading label
- ❑ Retrofit installation is complete

# Brake Bleeding Instructions

Includes power and manual bleeding instructions

**UFP** *Bilboly* **WORKING TOOLS** **BLEEDING PROCEDURE** Work Instruction FRED WANG 3/31/09

**1**  
USE CLEAN DOT 3  
FLUID WITH NO AIR  
BUBBLES

**2**  
CONNECT BLEEDER  
CLAMP

**3**  
TURN ON BLEEDER  
VALVE  
(15 PSI MIN.; 30 PSI MAX.)

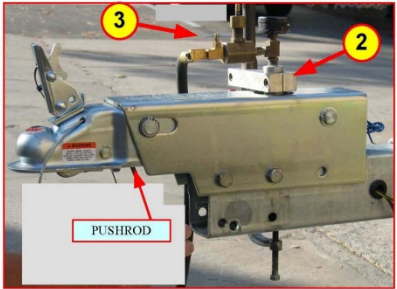

**4**  
OPEN BLEED SCREW  
AT 1<sup>ST</sup> CALIPER

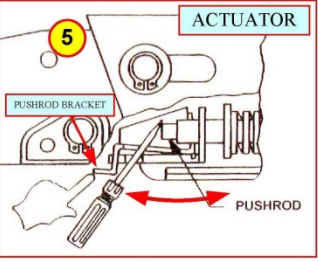
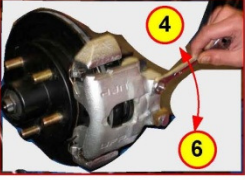

**5**  
STROKE PUSHROD  
(1<sup>ST</sup> CALIPER ONLY)

- PUSH UP AND HOLD PUSHROD RELEASE BRACKET.
- USE FLAT SCREW DRIVER STROKE PUSHROD 6 FULL STROKES.
- PULL OUT SCREW DRIVER AND CONFIRM PUSHROD IS EXTENDED BACK TO RELEASED POSITION.
- PUSHROD BRACKET SHOULD MOVE UP AND DOWN FREELY.

**6**  
TIGHTEN  
BLEED SCREW

- TIGHTEN BLEED SCREW AT CALIPER WHEN ALL AIR IS PURGED. (IT WILL TAKE 30 SECONDS FOR AIR BUBBLES TO REACH THE CALIPER.)

**7**  
BLEED OTHER WHEELS  
IN SEQUENCE

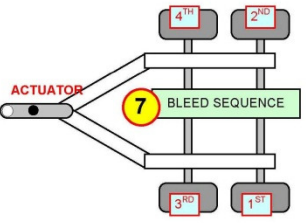

FINISH

## MANUAL BLEEDING OF THE BRAKE SYSTEM



If you are not skilled in performing the following procedures, have a qualified service shop perform the job.

Check that all hydraulic fittings are secure. Read and understand all instructions before starting. Two people are required for manual bleeding.

1. Remove the master cylinder reservoir plug and fill the reservoir with brake fluid. Use either DOT 3 or DOT 4 automotive brake fluid. Follow instructions on brake fluid container. Avoid shaking brake fluid container and pour fluid slowly to minimize air entrapment. Let fluid in reservoir stand until completely free of air bubbles.
2. **IMPORTANT:** Before bleeding brake lines, bleed the actuator master cylinder. Insert a screw driver through hole in bottom of inner member and use short strokes to pry on pushrod (while holding safety release bracket up) until no air bubbles are seen coming from small orifice hole in the bottom of the master cylinder reservoir.
3. Start bleeding procedure on the brake furthest from master cylinder.
4. At the brake assembly, connect a transparent bleeder hose to bleed screw fitting on wheel cylinder and submerge free end into a container partially filled with brake fluid. Do not reuse this fluid.
5. The first person strokes the pushrod slowly while holding safety release bracket up. The second person opens the bleed screw fitting. He then closes the bleed screw fitting **BEFORE** the first person **SLOWLY** releases the pushrod. Repeat this procedure until the fluid expelled from the bleeder hose is free of air bubbles. Remember to always tighten the bleeder screw before releasing pushrod. During this procedure, the master cylinder reservoir fluid level must be maintained at no less than 1/2 full.
6. Repeat steps 4 and 5 for the other brake and the brakes on the front axle, if equipped with tandem brake axles.
7. If installation is tandem axle with brakes on both axles, repeat bleeding procedure on rear axle brakes for the second time to assure purging of all air in system.
8. As a final check after bleeding is completed, stroke pushrod and check to be sure brake system is pressurized by attempting to rotate a tire.
9. Push up on the safety release bracket to ensure that pushrod is in released position.
10. After bleeding has been completed, re-check fluid level in master cylinder. Fill the master cylinder reservoir to indicator on reservoir plug. Do not overfill.

**CAUTION**

**IMPORTANT: DO NOT USE BRAKE FLUID DRAINED FROM BRAKE SYSTEM TO REFILL MASTER CYLINDER RESERVOIR AS SUCH FLUIDS CONTAIN CONTAMINANTS FROM SYSTEM WHICH MAY RESULT IN BRAKE FAILURE OR COSTLY REPAIRS.**

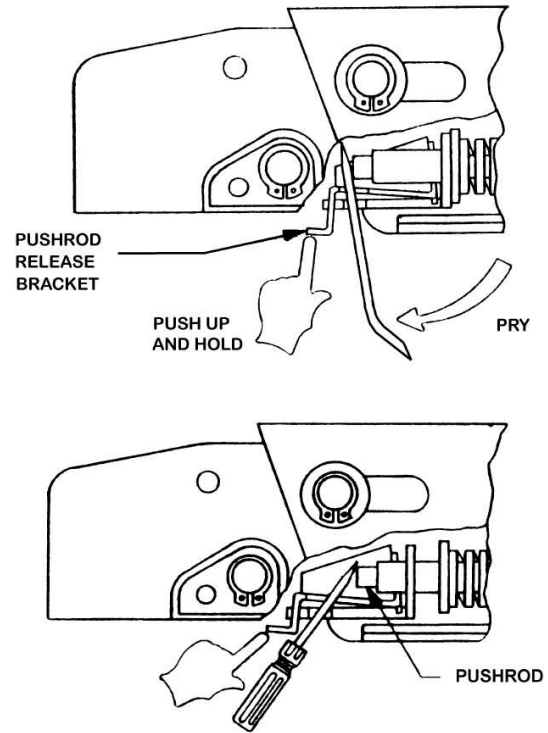

**FIGURE 16 STROKING PUSHROD TO BLEED BRAKES**