



Safety Recall: Accessory Trailer Hitch Wire Harness Is Mis-Wired

BACKGROUND

About 100 accessory trailer hitch wire harnesses may have an incorrectly wired connector. As a result, when towing a trailer, the turn signals on the trailer operate only while braking. This condition significantly increases the risk of a crash.

CUSTOMER NOTIFICATION

All owners of potentially affected vehicles will be sent a notification of this safety recall.

Some vehicles affected by this recall may be in your new or used vehicle inventory. As a matter of Federal law, the harnesses in these vehicles **must** be repaired before they are sold.

Should a dealership sell an unrepaired vehicle that subsequently causes injury or damage because of the recalled item, the dealership will be solely responsible to the damaged party, and will be required to defend and indemnify American Honda for any resulting claims. To see if a vehicle in inventory is affected by this recall, do the **INSPECTION PROCEDURE** and, if necessary, the **REPAIR PROCEDURE** before selling it.

CORRECTIVE ACTION

If the vehicle is equipped with a Honda Genuine accessory trailer hitch wire harness, verify that the connector is properly wired using the 4-pin circuit tester. If the connector is not properly wired, reposition the terminals in the harness connector (see **REPAIR PROCEDURE**).

If the vehicle is **not** equipped with a Honda Genuine accessory trailer hitch wire harness, either you or your customer must fill out and return a *Campaign Status Change Request form* to remove the vehicle from this recall. We supplied your dealership with a small quantity of these response forms; additional forms can be ordered through Helm.

Before doing work on a vehicle, verify its eligibility by doing an iN VIN status inquiry.

TOOL INFORMATION

Terminal Pin Tool Set: T/N 07JAZ-002050A

4-Pin Circuit Tester: (commercially available) T/N TLT5

NOTE: One circuit tester will be shipped to each dealership starting in September 2012.

REQUIRED MATERIALS

EPT Sealer 3T: P/N 06990-SA5-000

(One roll repairs about 12 vehicles)

WARRANTY CLAIM INFORMATION

OP#	Description	FRT
0195A1	Inspect the Honda Genuine accessory trailer hitch wire harness.	0.2
A	Add to remove, reverse affected wires, and reinstall the accessory trailer hitch wire harness connector.	0.1

Failed Part: P/N 08L91-SCV-100

Defect Code: 5PJ00

Symptom Code: S5300

Skill Level: Repair Technician



INSPECTION PROCEDURE

1. Inspect for a trailer hitch harness at the rear bumper.

Is a **Honda Genuine** accessory trailer hitch wire harness present at the rear bumper?

Yes – Go to step 2.

No – Fill out a Campaign Status Change Request form if there is no harness on the vehicle, or if it is an aftermarket harness.

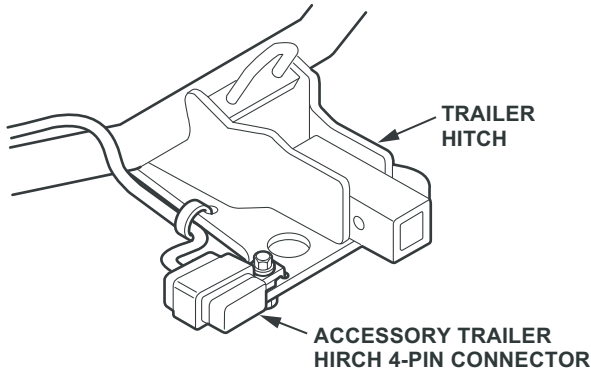

2. Remove the connector and turn it upside down. Insert the 4-pin circuit tester into the harness, then have an assistant test the turn signals and the brakes separately and together while you watch the tester.

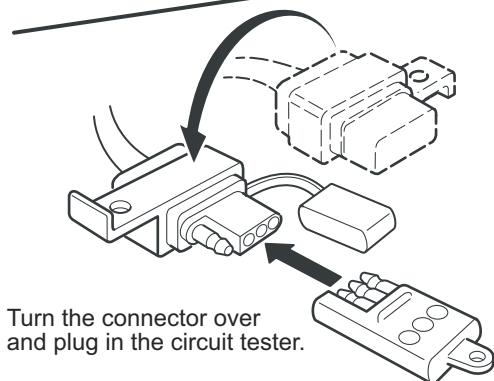
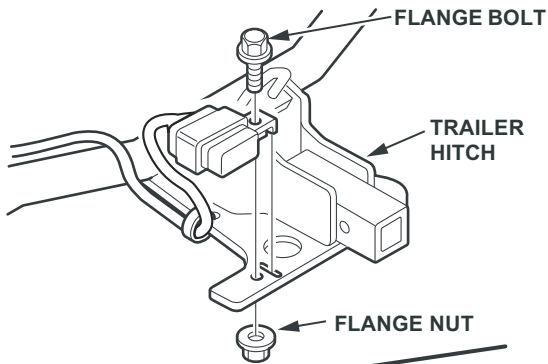

Do the turn signals and the brake lights work correctly?

Yes – No further action is needed. Reassemble and return the vehicle to the customer. Fill out a warranty claimform.

No – Go to step 3.

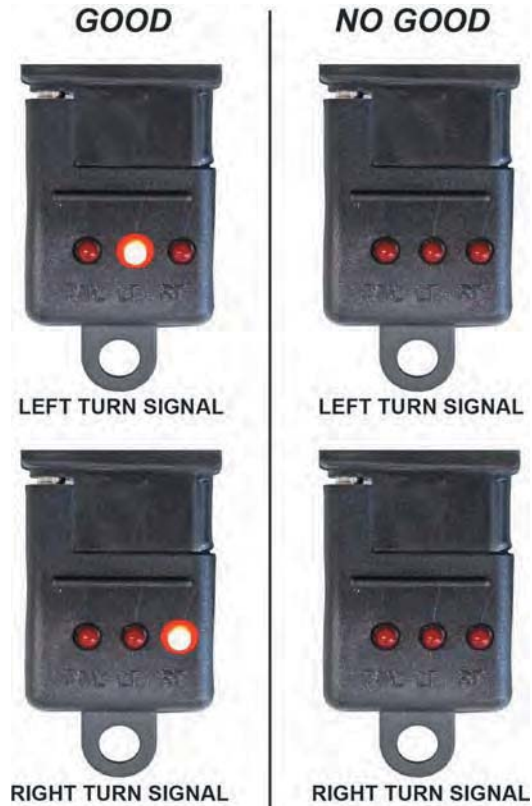

3. Remove the driver's dashboard lower cover by turning the knobs clockwise, then pull the lower cover out toward you to release the six retaining tabs.

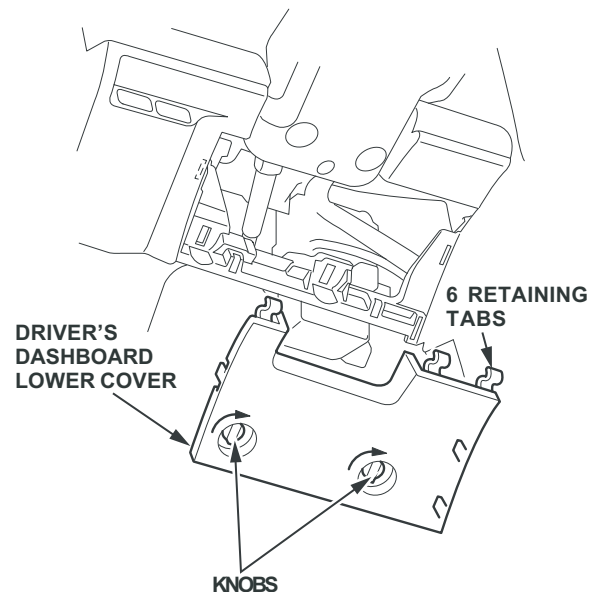

- Disconnect the connectors and remove the trailer hitch wire control unit harness from the vehicle.

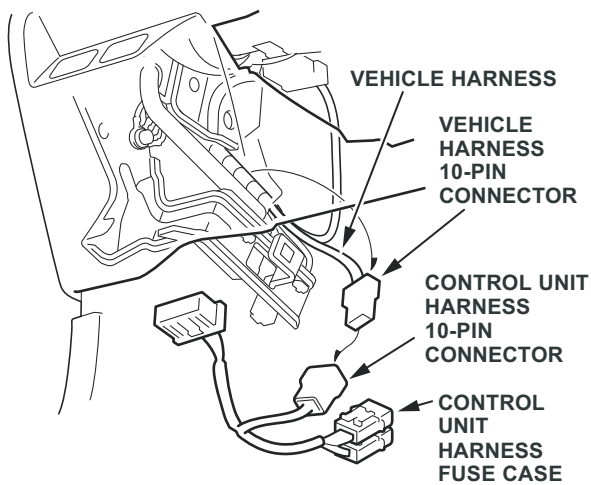
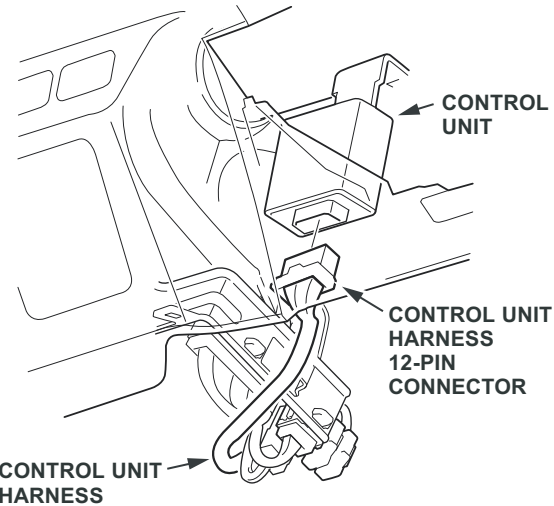
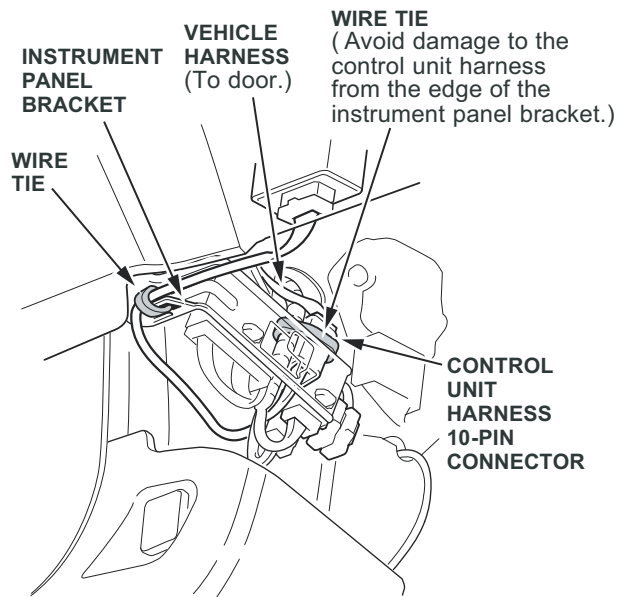

- Visually inspect the white/black wire positions at pins 8 and 9 in the 12-pin connector.

Is it correct?

Yes – This bulletin doesn't apply. Follow normal troubleshooting.

No – Go to REPAIR PROCEDURE.

CORRECT

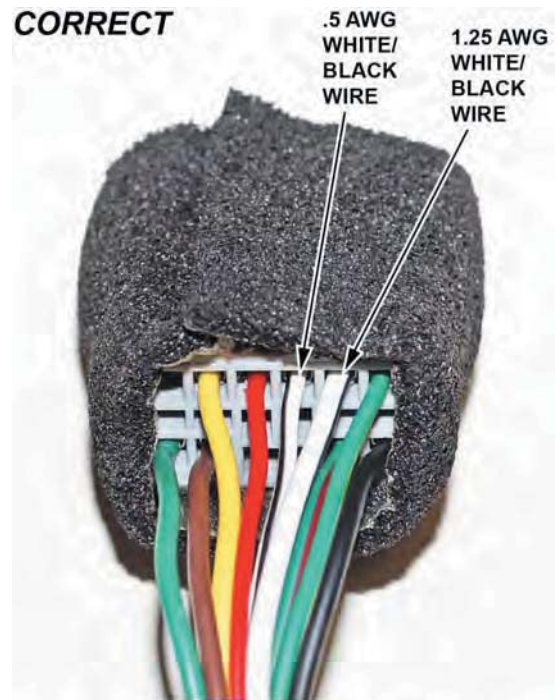

NOT CORRECT

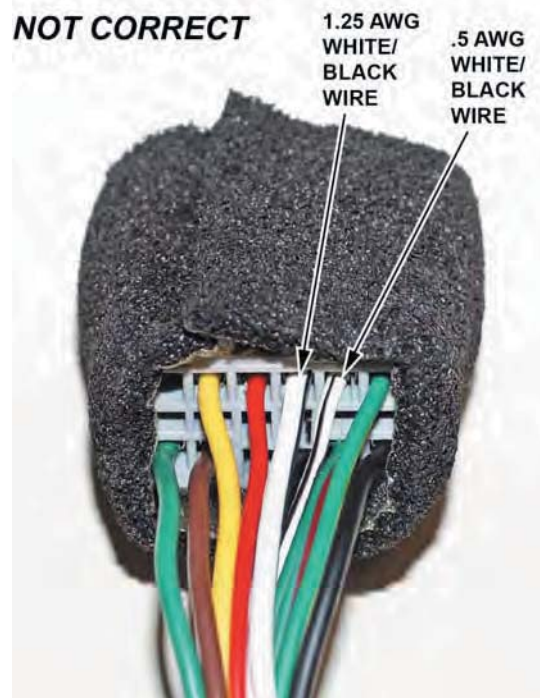

REPAIR PROCEDURE

1. Remove the foam wrap from around the 12-pin connector.
2. Lift up the connector locking tab.

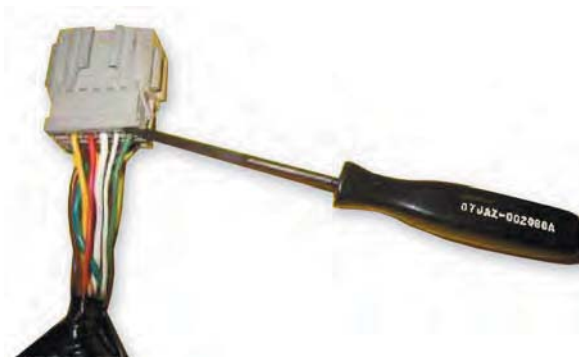

3. Using a terminal pin tool (T/N 07JAZ-002050A), remove the large White/Black wire and the small White/Black wire from the connector.

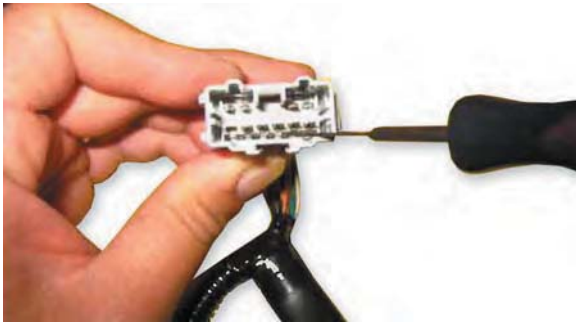

4. Reinsert the wires in their proper location.



5. Wrap the connector with foam tape (EPT sealer 3T), and reinstall the harness.



6. Reinstall the driver's dashboard lower cover.

