



Safety Recall: Front Door Latch Does Not Lock

BACKGROUND

In rare instances, simultaneous operation of the driver's or passenger's inner door handle and lock knob may cause the inner door handle release cable to become partially disengaged. When this occurs, the door may not latch when closed and/or the door may latch and close, but then open when the door locks are operated. These conditions can lead to the door unexpectedly opening while the vehicle is in motion.

If a customer is concerned about this issue before the vehicle is repaired, they can check the door is latched by doing the following every time the driver's or the front passenger's door is opened and closed:

- Cycle the locks to the lock position after the doors are all closed.
- Confirm the doors have remained securely closed by pushing against the door while the lock knob for the driver's and the front passenger's door is in the locked position.
- Once the door is confirmed as being closed, the door latch won't release until the inner or outer door handle is pulled (the door must be unlocked to open from the outer handle).

NOTE: This problem applies to the driver's and front passenger's door only. The rear doors are OK.

CUSTOMER NOTIFICATION

Owners of affected vehicles will receive a notification of this campaign in August 2012.

Do an **iN VIN status inquiry** to make sure the vehicle is shown as eligible.

Some vehicles affected by this campaign may be in your new or used vehicle inventory. These vehicles must be repaired before they are sold.

Should a dealership sell an unrepaired vehicle that subsequently causes an injury or damage because of the recalled item, the dealership will be solely responsible to the damaged party, and will be required to defend and indemnify American Honda for any resulting claims. To see if a vehicle in inventory is affected by this campaign, do a VIN status inquiry before selling it.

CORRECTIVE ACTION

Replace both the driver's and the front passenger's door latches.

PARTS INFORMATION

Door Latch Kit: P/N 06720-T0A-305
(Each kit repairs both the driver's and front passenger's side doors.)

WARRANTY CLAIM INFORMATION

OP#	Description	FRT
7481B7	Replace the driver's door latch.	0.4
A	Replace the front passenger's door latch.	0.4

Failed Part: P/N 72110-T0A-A11

Defect Code: 5ND00

Symptom Code: S4700

Skill Level: Repair Technician

REPAIR PROCEDURE

Driver's side shown, passenger's side similar.

NOTE: This procedure is an outline form that you can also use as a checklist for the repair. If you need more details on the procedures listed below, view them online:

- Front Door Outer Handle Removal and Installation
- Front Door Panel Removal and Installation

1. Remove the front door lock cylinder.

- Remove the latch protector, and remove the bolt.

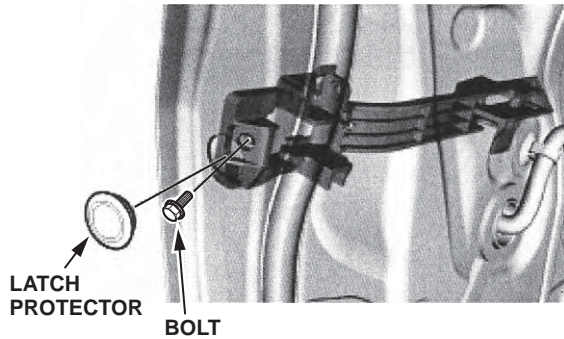

- Pull out the lock cylinder.

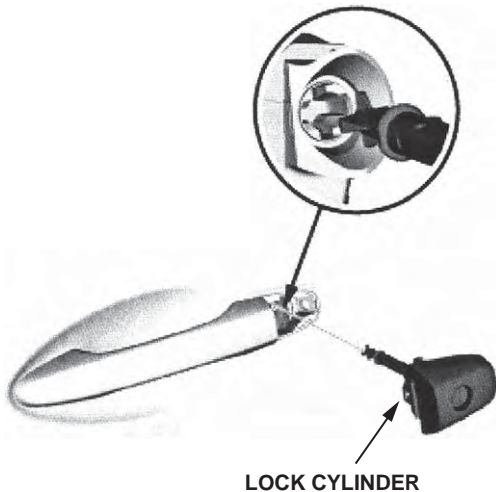

2. Remove the front door panel.

3. Remove the front door plastic cover as needed.

4. Remove enough of the glass run channel from the front door center lower channel so that you can remove the lower channel.

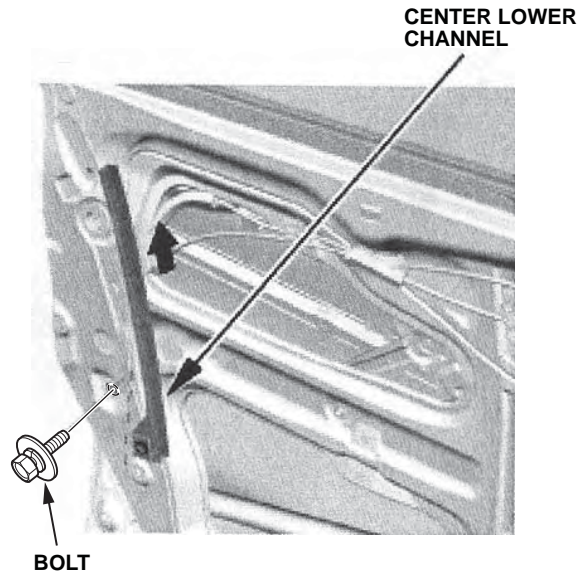

5. Remove the front door latch.

- Remove the three TORX bolts, and disconnect the connector.

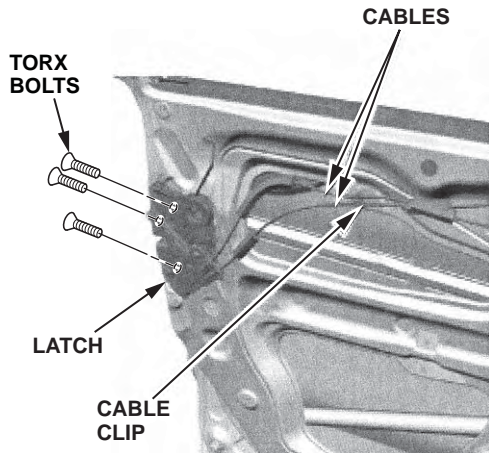

- Lower the door latch to slide it off the outer handle rod, and remove it.

NOTE:

- You do not need to replace the rod fastener because the handle rod is not removed.
- Take care not to bend the inner handle cable and the latch cable.

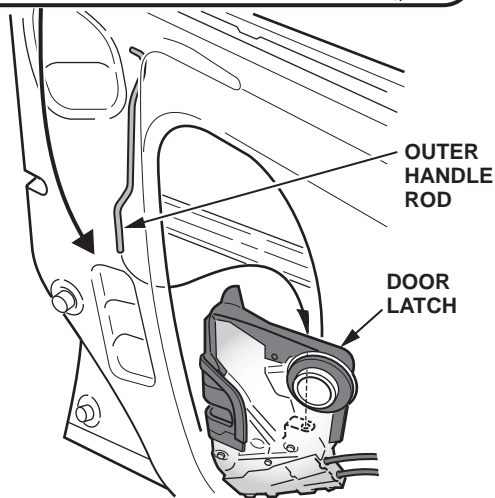
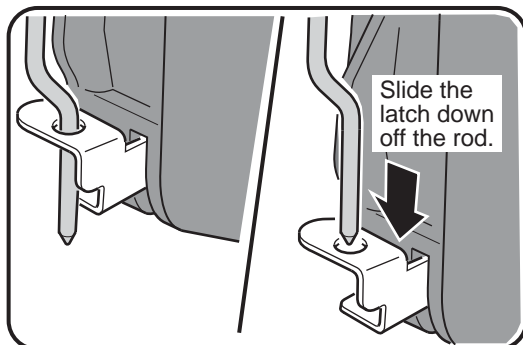

6. Replace the front door latch.

- Open the latch protector cover.

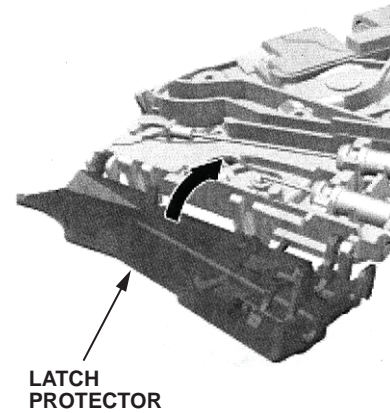

- Disconnect the inner handle cable and the latch cable from the front door latch.

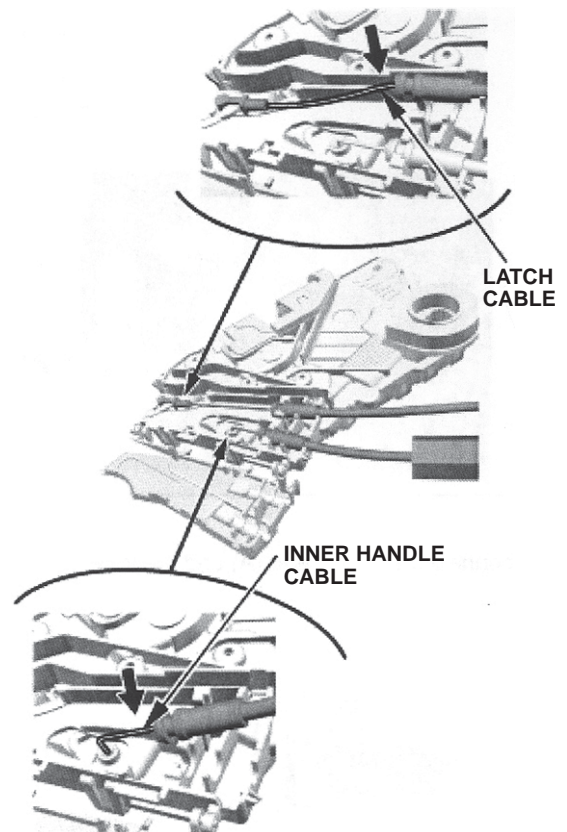

- Install the new door latch, and connect the inner handle cable and the latch cable.
- Close the latch protector cover.

7. Reinstall the door latch making sure the outer handle rod is attached, and torque the TORX bolts to **5.4 N·m (4 lb-ft)**. Reconnect the connector.

NOTE: Take care not to bend the inner handle cable and the latch cable.

8. Install the center lower channel, and torque the bolt to **7.4 N·m (5.4 lb-ft)**.

9. Reinstall the plastic cover.
10. Reinstall the front door panel.
11. Reinstall the front door lock cylinder, and torque the bolt to **9.4 N·m (6.9 lb-ft)**. Using the key, make sure you can lock and unlock the door.

NOTE: If the door lock cylinder doesn't go in properly or you can't lock or unlock the door with the key, refer to Service News article titled *Door Won't Lock or Unlock with the key*.

12. Repeat steps 2 thru 10 for the front passenger's door.