



Applies To: **2012 CR-V** – Check the iN VIN status for eligibility

**August 10, 2012**

## Safety Recall: Front Door Latch Does Not Lock and Front Door Does Not Open From the Inside

(Supersedes 12-040, dated July 19, 2012, to revise the information marked by the black bars)

(Replaces 12-022, *Front Door Does Not Open From the Inside*)

### REVISION SUMMARY

- The BACKGROUND was changed.
- An example of the customer letter was added.

### BACKGROUND

Simultaneous operation of the driver's or passenger's inner door handle and either the manual or power door lock may result in the inner door handle release cable becoming partially disengaged. When this occurs the door may not latch when closed and/or the door may latch and close, but then open when the door locks are operated; either case may result in the affected door opening unexpectedly.

If a customer is concerned about this issue before the vehicle is repaired, they can check the door is latched by doing the following every time the driver's or the front passenger's door is opened and closed:

- Cycle the locks to the lock position after the doors are all closed.
- Confirm the doors have remained securely closed by pushing against the door while the lock knob for the driver's and the front passenger's door is in the locked position.
- Once the door is confirmed as being closed, the door latch won't release until the inner or outer door handle is pulled (the door must be unlocked to open from the outer handle).

NOTE: This problem applies to the driver's and front passenger's door only. The rear doors are OK.

### CUSTOMER NOTIFICATION

Owners of affected vehicles have or will receive a notification of this campaign in August 2012. An example of the customer notification is included at the end of this service bulletin.

Do an **iN VIN status inquiry** to make sure the vehicle is shown as eligible.

Some vehicles affected by this campaign may be in your new or used vehicle inventory. These vehicles must be repaired before they are sold.

Should a dealership sell an unrepaired vehicle that subsequently causes an injury or damage because of the recalled item, the dealership will be solely responsible to the damaged party, and will be required to defend and indemnify American Honda for any resulting claims. To see if a vehicle in inventory is affected by this campaign, do a VIN status inquiry before selling it.

### CORRECTIVE ACTION

Replace both the driver's and the front passenger's door latches and inner handles.

### PARTS INFORMATION

Door Latch Kit: P/N 06720-T0A-305  
(Each kit repairs both the driver's and front passenger's side doors.)

Inner Handle Kit:  
P/N 06721-T0A-305ZA (Beige)  
P/N 06721-T0G-305ZA (Beige)  
P/N 06721-T0A-305ZB (Black)  
P/N 06721-T0G-305ZB (Black)  
(Each kit repairs both the driver's and front passenger's side doors.)

NOTE: You may receive P/N 06721-T0G-305ZA (Beige), instead of 06721-T0A-305ZA (Beige) or P/N 06721-T0G-305ZB (Black) instead of 06721-T0A-305ZB (Black); the parts are the same.

### WARRANTY CLAIM INFORMATION

OP#	Description	FRT
8181C8	Replace the driver's inner door handle and door latch.	0.5
A	Replace the front passenger's inner door handle and door latch.	0.5

Failed Part: P/N 72110-T0A-A11

Defect Code: 5ND00

Symptom Code: S4500

Skill Level: Repair Technician



## REPAIR PROCEDURE

Driver's side shown, passenger's side similar.

NOTE: This procedure is an outline form that you can also use as a checklist for the repair. If you need more details on the procedures listed below, view them online:

- Front Door Outer Handle Removal and Installation
- Front Door Panel Removal and Installation

1. Remove the front door lock cylinder.
  - Remove the latch protector, and remove the bolt.

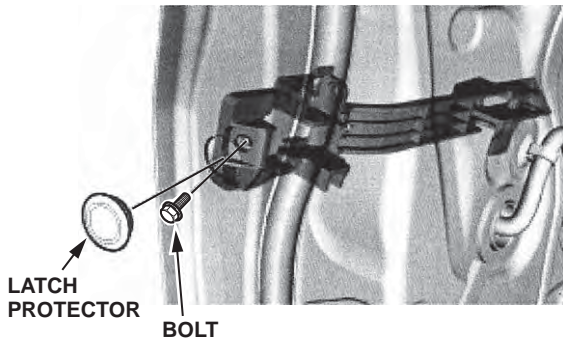

- Pull out the lock cylinder.

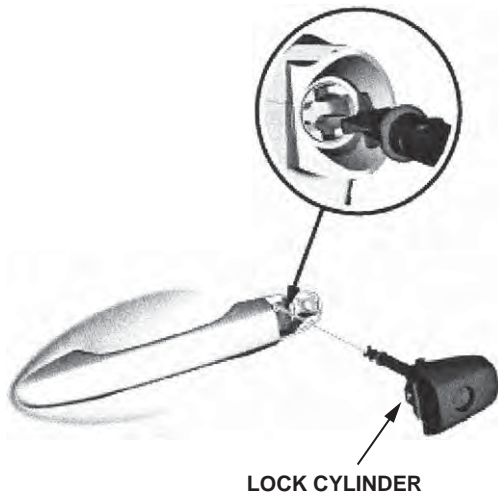

2. Remove the front door panel.
3. Remove the front door plastic cover as needed.

4. Remove enough of the glass run channel from the front door center lower channel so that you can remove the lower channel.

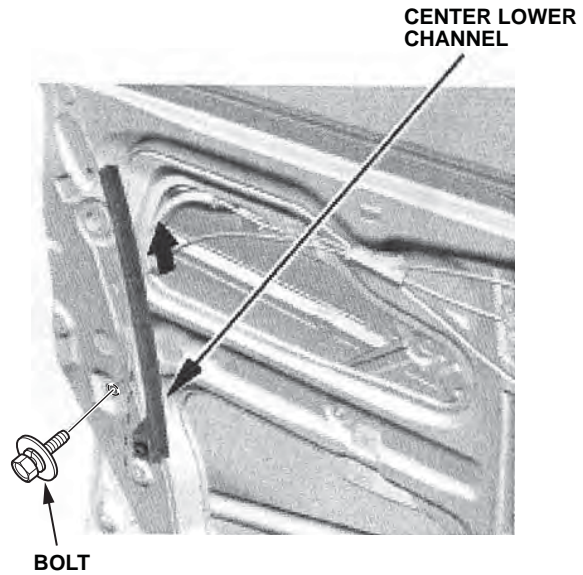

5. Remove the front door latch.

- Remove the three TORX bolts, and disconnect the connector.

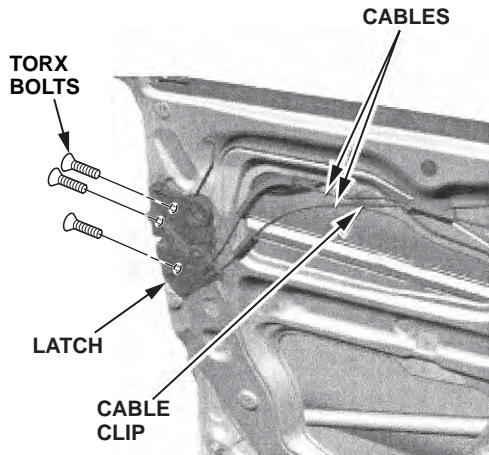

- Lower the door latch to slide it off the outer handle rod, and remove it.

NOTE:

- You do not need to replace the rod fastener because the handle rod is not removed.
- Take care not to bend the inner handle cable and the latch cable.

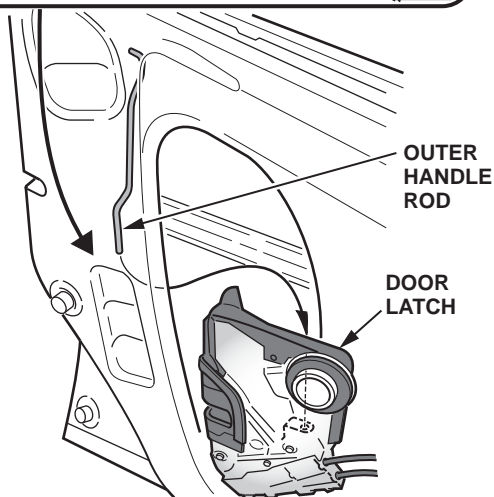
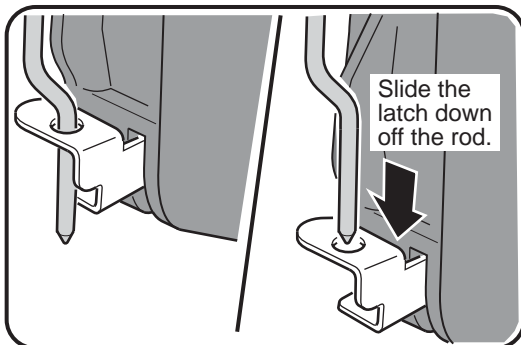

6. Replace the inner door handle.

- Release the cable fasteners, then disconnect the latch cable and the inner handle cable in the order shown.

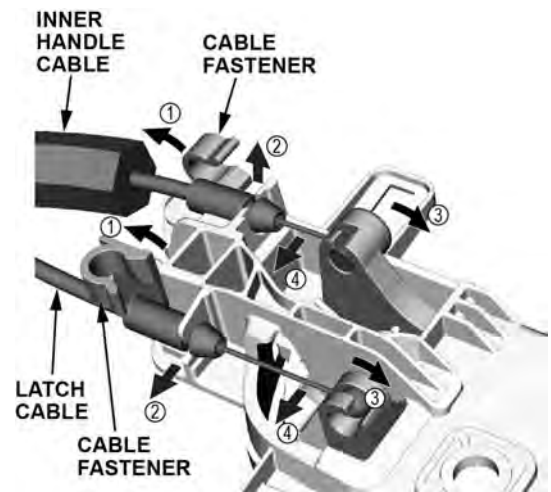

- Install the latch cable and inner handle cable to the new inner handle, and secure the cable fasteners.

7. Replace the front door latch.
  - Open the latch protector cover.

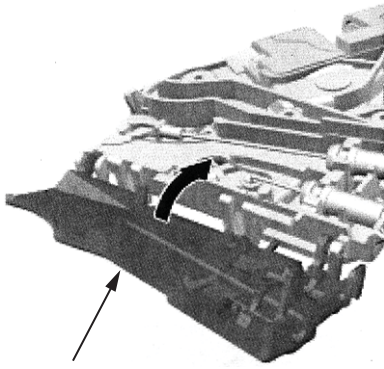

LATCH PROTECTOR

- Disconnect the inner handle cable and the latch cable from the front door latch.

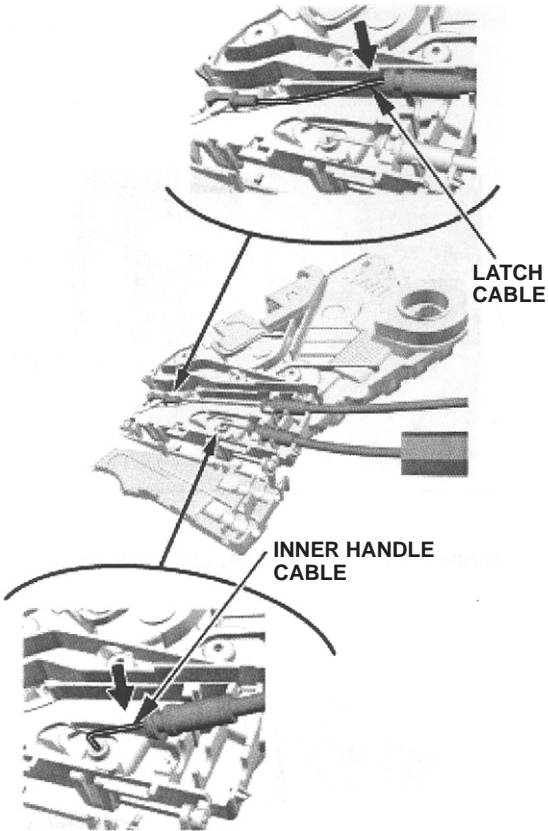

LATCH CABLE

INNER HANDLE CABLE

- Install the new door latch, and connect the inner handle cable and the latch cable.
  - Close the latch protector cover.
8. Reinstall the door latch making sure the outer handle rod is attached, and torque the TORX bolts to **5.4 N·m (4 lb-ft)**. Reconnect the connector.  
NOTE: Take care not to bend the inner handle cable and the latch cable.

9. Install the center lower channel, and torque the bolt to **7.4 N·m (5.4 lb-ft)**.
10. Reinstall the plastic cover.
11. Reinstall the front door panel.
12. Reinstall the front door lock cylinder, and torque the bolt to **9.4 N·m (6.9 lb-ft)**. Using the key, make sure you can lock and unlock the door.  
NOTE: If the door lock cylinder doesn't go in properly or you can't lock or unlock the door with the key, refer to Service News article titled *Door Won't Lock or Unlock with the key*.
13. Repeat steps 2 thru 11 for the front passenger's door.
14. Make sure all doors lock and unlock properly using the keyless remote and the driver's and the front passenger's power door locks.

*Example of Client Letter*

August 2012

**Safety Recall: Front Door Latch Does Not Lock and Front Door Does Not Open From the Inside – NHTSA Recall 12V-338**

Dear Honda CR-V Owner:

This notice is sent to you in accordance with the requirements of the National Traffic and Motor Vehicle Safety Act.

**What is the reason for this notice?**

Honda has decided that a defect which relates to motor vehicle safety exists in the front door latches of certain 2012 model year CR-V vehicles. If the manual or power door lock is activated while an interior front door handle is being operated by an occupant, there is a possibility that the door may not properly latch. If a door is not fully latched, the door may open while driving or in a crash. A door that can unexpectedly open increases the risk of personal injury to the vehicle occupants.

**What should you do?**

Call any authorized Honda dealer and make an appointment to have the front door latches and interior front door handles on your vehicle replaced *at no cost to you*. The replacements may be completed in approximately one hour; however, your vehicle will need to be at the dealer for a longer period of time. We recommend that you plan to leave your vehicle for half a day to allow the dealer flexibility in scheduling.

**Who to contact if you experience problems**

If you are not satisfied with the service you receive from your Honda dealer, you may write to:

American Honda Motor Co., Inc.  
Honda Automobile Customer Service  
Mail Stop 500-2N-7A  
1919 Torrance Blvd.  
Torrance, CA 90501-2746

If you believe that American Honda or the dealer has failed or is unable to remedy the defect in your vehicle, without charge, within a reasonable period of time (60 days from the date you first contact the dealer for a repair appointment), you may submit a complaint to:

Administrator  
National Highway Traffic Safety Administration  
1200 New Jersey Ave., SE  
Washington, DC 20590

Or call the toll-free Safety Hotline at  
1-888-327-4236 (TTY 1-800-424-9153), or go to  
<http://www.safercar.gov>.

**What to do if you feel this notice is in error**

Registration records indicate that you are the current owner or lessee of a 2012 CR-V involved in this campaign. If this is not the case, or the name/address information is not correct, please *complete and sign* the Information Change Card and return it in the enclosed postage-paid envelope. We will then update our records.

**Lessor Information**

Federal law requires that any vehicle lessor receiving this recall notice must forward a copy of this notice to the lessee within 10 days.

**If you have questions**

If you have any questions about this notice, or need assistance with locating a Honda dealer, please call Honda Automobile Customer Service at 800-999-1009, and select option 4. You can also locate a dealer online at [Hondacars.com](http://Hondacars.com).

We apologize for any inconvenience this campaign may cause you.

Sincerely,

**American Honda Motor Co., Inc.  
Honda Automobile Division**