



RECALL CAMPAIGN BULLETIN

Reference:

NTB12-058

Date:

July 20, 2012

VOLUNTARY SAFETY RECALL CAMPAIGN 2012 JUKE REAR SEATBACK STRIKER

CAMPAIGN ID #: R1216
NHTSA #: 12V-328
APPLIED VEHICLE: 2012 Juke (F15)

Check Service COMM to confirm campaign eligibility.

INTRODUCTION

Nissan is conducting a voluntary safety recall campaign on certain 2012 Juke vehicles to replace the rear seatback strikers. This procedure will be performed at no charge for parts and labor.

IDENTIFICATION NUMBER

Nissan has assigned identification number R1216 to this campaign. This number must appear on all communications and documentation of any nature dealing with this campaign.

DEALER RESPONSIBILITY

Dealers are to correct each vehicle falling within the range of this campaign that enters the service department. This includes vehicles purchased from private parties or presented by transient (tourist) owners and vehicles in a dealer's inventory.

Nissan Bulletins are intended for use by qualified technicians, not 'do-it-yourselfers'. Qualified technicians are properly trained individuals who have the equipment, tools, safety instruction, and know-how to do a job properly and safely. NOTE: If you believe that a described condition may apply to a particular vehicle, DO NOT assume that it does. See your Nissan dealer to determine if this applies to your vehicle.

SERVICE PROCEDURE

CAUTION: Use protective coverings as needed to protect interior surfaces while performing this procedure.

1. Open the rear door (hatch).

2. Fold down the rear seatbacks.



Figure 1

NOTE: Steps 3, 4, and 5 are for 2WD models. For 4WD models, skip to step 6.

3. For 2WD models: Fold the luggage floorboard forward and rest it on the rear seatbacks.



Figure 2

4. For 2WD models: Remove the luggage floor box.

NOTE: For 2WD models the spare tire does not need to be removed.



Figure 3

5. For 2WD models: Unhook the straps from the luggage floorboard and remove it from the vehicle.



Figure 4

NOTE: Steps 6, 7, and 8 are for 4WD models. For 2WD models, skip to step 9.

6. For 4WD models: Remove the luggage floorboard.



Figure 5

7. For 4WD models: Remove the spare tire.



Figure 6

8. For 4WD models: Remove the left side luggage floor rear spacer.



Figure 7

9. Remove the body welt (weather strip) along the bottom and both sides of the rear door (hatch) opening.



Figure 8

10. Use a plastic trim tool to snap loose and remove the luggage rear plate.



Figure 9

11. Remove the rear seatbacks as follows:

- a. Remove the 8 rear seatback bolts shown (circled) in Figure 10.
- b. Remove the rear center seat bolt anchor bolt shown in Figure 10.
- c. Remove both seatbacks from the vehicle.

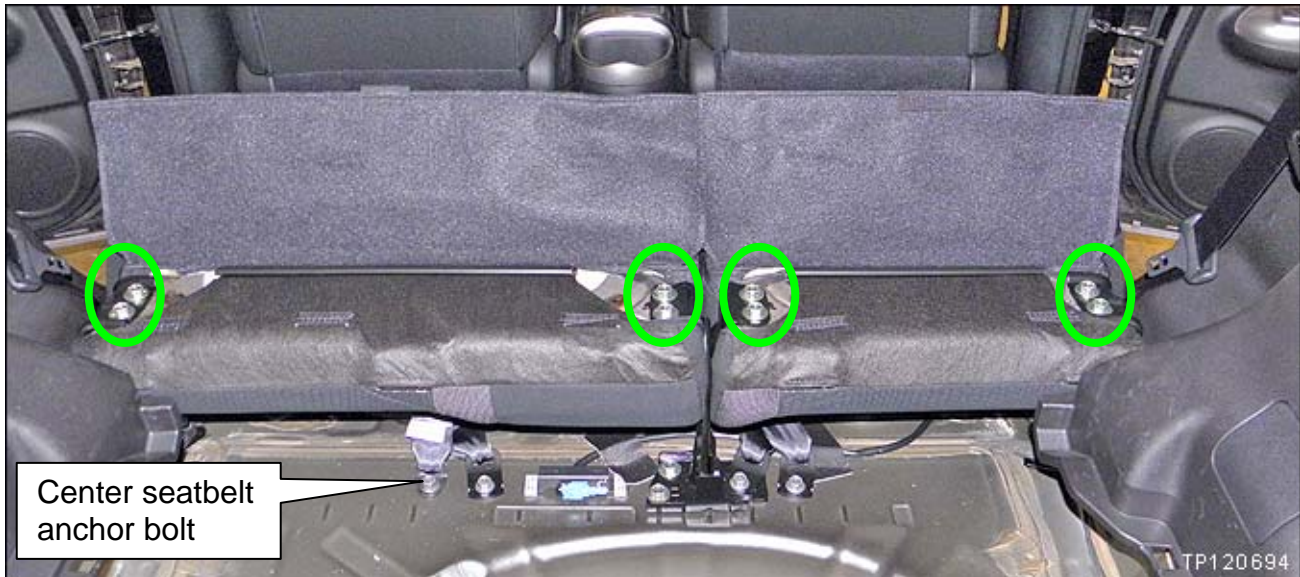

Figure 10

12. Remove the luggage room lamp:

- Luggage room lamp is located on the right side lower luggage finisher.
- Use a plastic trim tool to snap out the lamp.
- Disconnect the electrical connector.



Figure 11

CAUTION:

- Note the location of the seat cushion hooks (See Figures 12 and 13).
- When removing the seat cushion, pull up as close as possible to each seat cushion hook.
- If excessive force is used to pull up on the seat cushion, the seat cushion hook and wire will be deformed.

13. Remove the rear seat cushion.

- Approximate location of cushion hooks is shown with arrows in Figures 12.

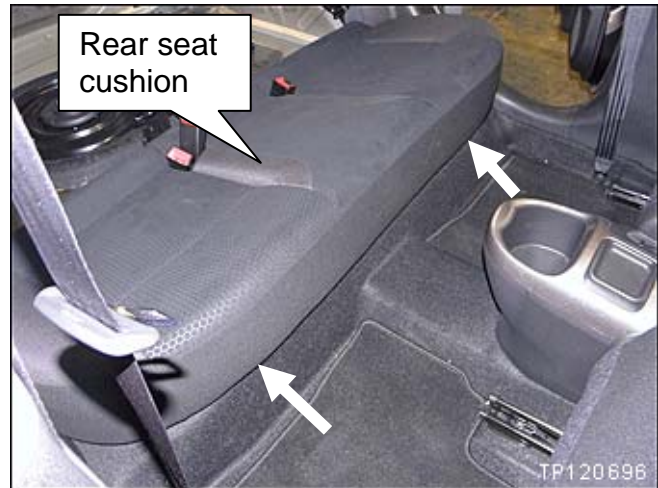

Figure 12

- Pull up on the cushion hooks to disengage them.

CAUTION: Pull up as close as possible to the hooks to avoid damaging the cushion hooks and wire.

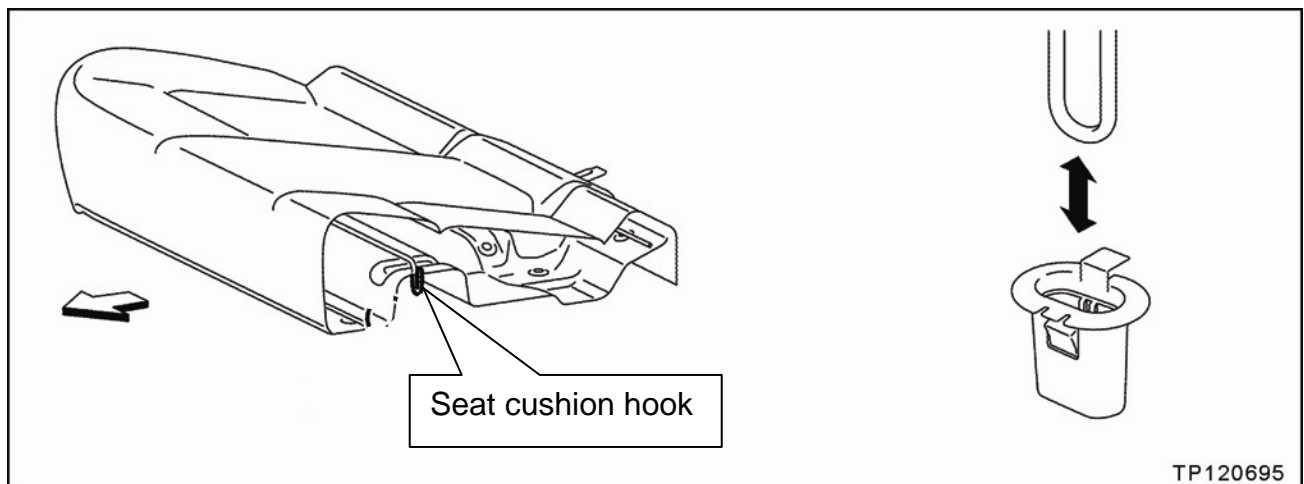

Figure 13

NOTE: Photos in Figures 14 through 23 are of the passenger side. The driver side is a mirror image.

14. Remove the seatback side hinge.

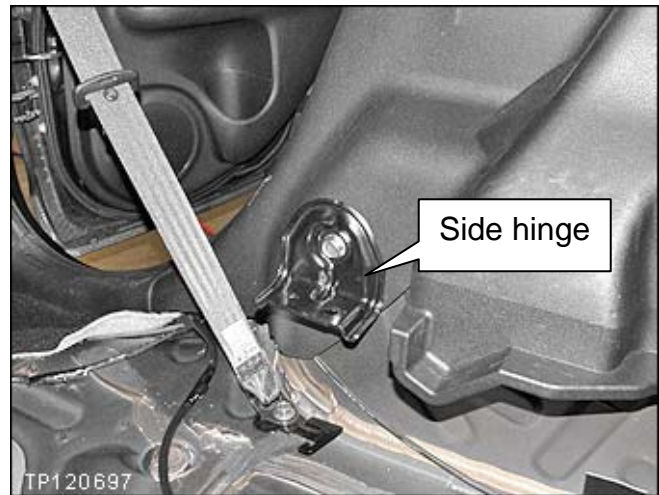

Figure 14

15 Remove the rear side door kicking plate.



Figure 15

16. Remove the rear side door body welt (weather-strip).



Figure 16

17. Remove the luggage lower finisher.

- Approximate location of 6 clips is shown with circles.
- Use a plastic trim tool as needed.

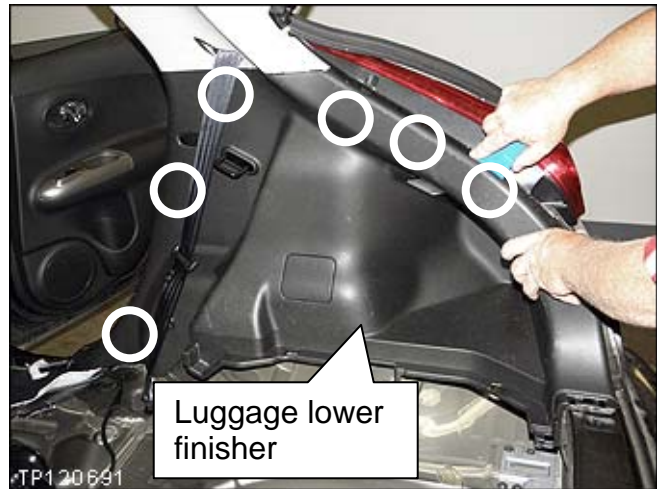

Figure 17

18. Remove the old rear seatback striker.

- Mark the old striker so it will not be confused with the new striker.
- Do not reuse the old strikers.

NOTE:

- Passenger side shown – 2 bolts and 1 nut.
- The driver side has 3 bolts.

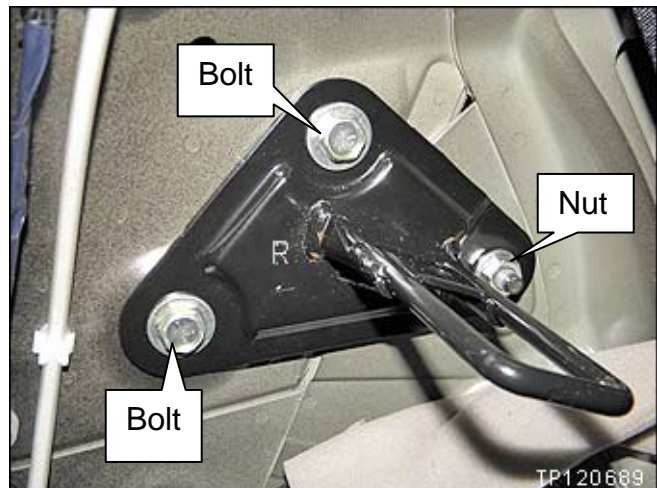

Figure 18

19. Install the new rear seatback striker.

- Make sure the correct striker is installed.
Right side is marked with an **R**.
Left side is marked with an **L**.
- Tighten bolts/nut in the order shown.
- Torque bolts/nut to:
45 Nm (4.6 kg-m, **33 ft-lb**)

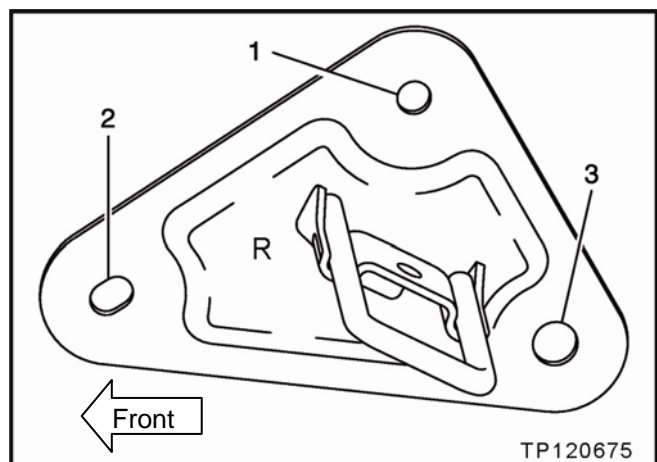

Figure 19

20 Reinstall the luggage lower finisher.

- For the passenger side, make sure the room lamp electrical connector is pulled through the room lamp opening.
- Approximate location of 6 clips is shown with circles.
- Make sure all clips are securely snapped in place.

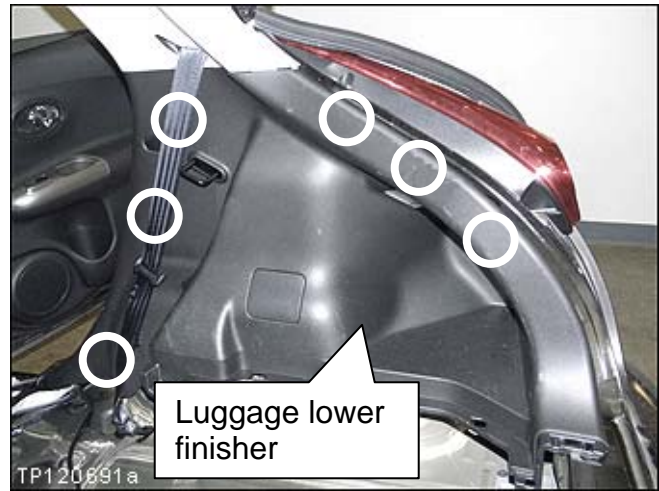

Figure 20

21. Reinstall the seatback side hinge.

- Torque bolt to:
45 Nm (4.6 kg-m, **33 ft-lb**)

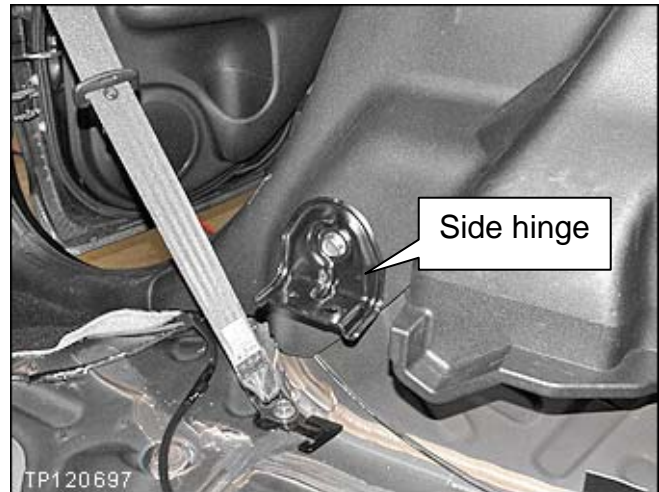

Figure 21

22. Reinstall the rear side door body welt (weather-strip).

- Make sure the body welt is installed with the kicking plate “cut-out” positioned correctly as shown.

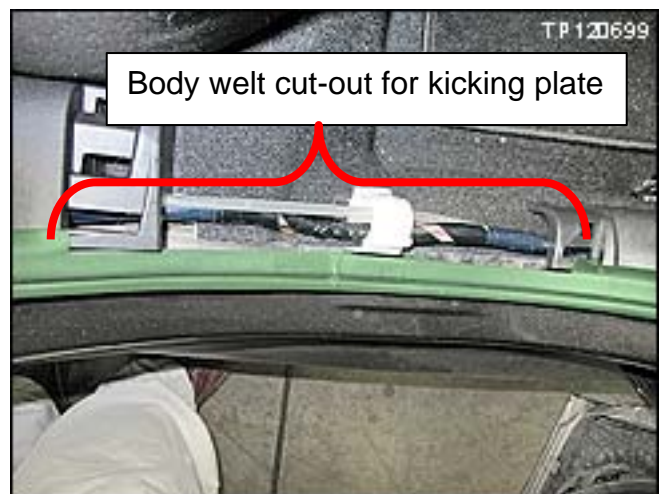

Figure 22

23. Reinstall the rear side door kicking plate.



Figure 23

24. Install a new rear seatback striker on the opposite side.

- Follow steps 14 through 23 to replace the other striker.

25. Reinstall the luggage room lamp:

- Luggage room lamp is located on the right side lower luggage finisher.
- Reconnect the electrical connector and snap the lamp back in place.



Figure 24

26. Reinstall the rear seat cushion.

- Make sure seat belt latches are pulled through the seat.
- Make sure the center latch (it is marked center) is in the center position.

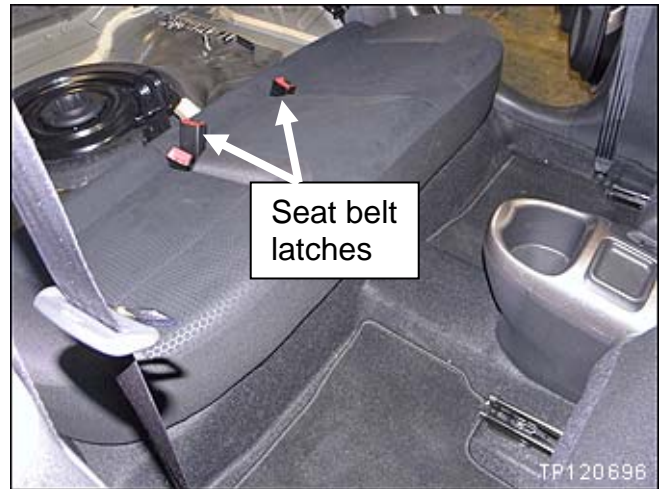

Figure 25

- Push down on the seat cushion to engage the cushion hooks.

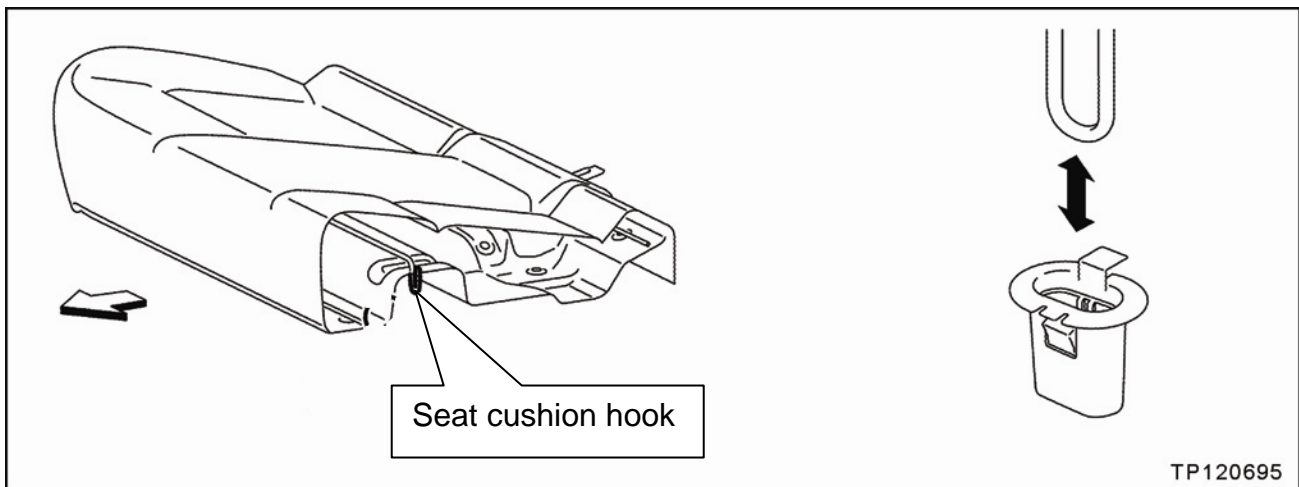

Figure 26

27. Reinstall the rear seatbacks (see Figure 27).

- Reinstall the 4 left side rear seatback bolts, tighten in the order shown:
Torque to 45 Nm (4.6 kg-m, **33 ft-lb**)
- Reinstall the 4 right side rear seatback bolts, tighten in the order shown:
Torque to 45 Nm (4.6 kg-m, **33 ft-lb**)
- Reinstall the rear center seat belt anchor bolt; torque to 49 Nm (5.0 kg-m, **36 ft-lb**).

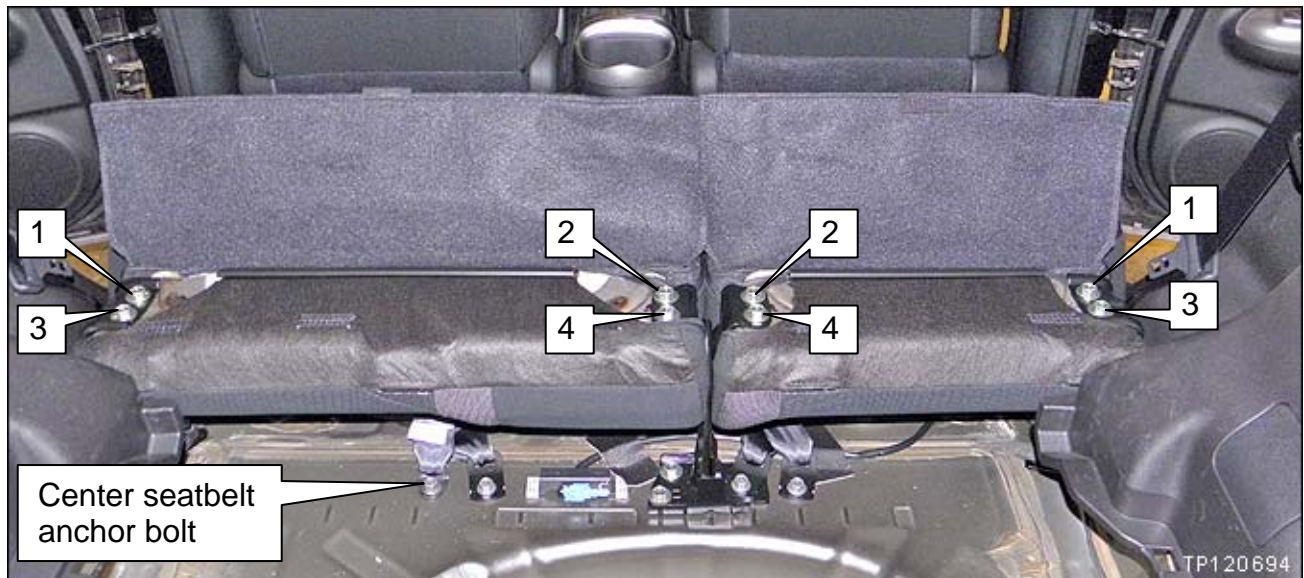

Figure 27

28. Reinstall the luggage rear plate.



Figure 28

29. Reinstall the rear door (hatch) body welt (weather-strip).

- Make sure the rubber alignment seal is installed in the ends of the body welt.



Figure 29

30. Reinstall the following items:

2WD models:

- Luggage floor box
- Luggage floor board; make sure to attach the straps

4WD models:

- Left side luggage floor rear spacer
- Spare tire
- Luggage floor board

31. Operate the rear seatback latch a few times to confirm smooth operation (no interference) and secure latching.

- If the seatback latch does not operate smoothly, see information on the next page.

NOTE: Latching of the rear seatbacks can be adjusted by:

- a. Loosening the bolts shown in Figure 30.
- b. Moving / shifting the position of the seatback as needed.
- c. Retightening the bolts enough to prevent shifting of the seatback.
- d. Recheck latch for smooth operation.
- e. Repeat above steps as needed.

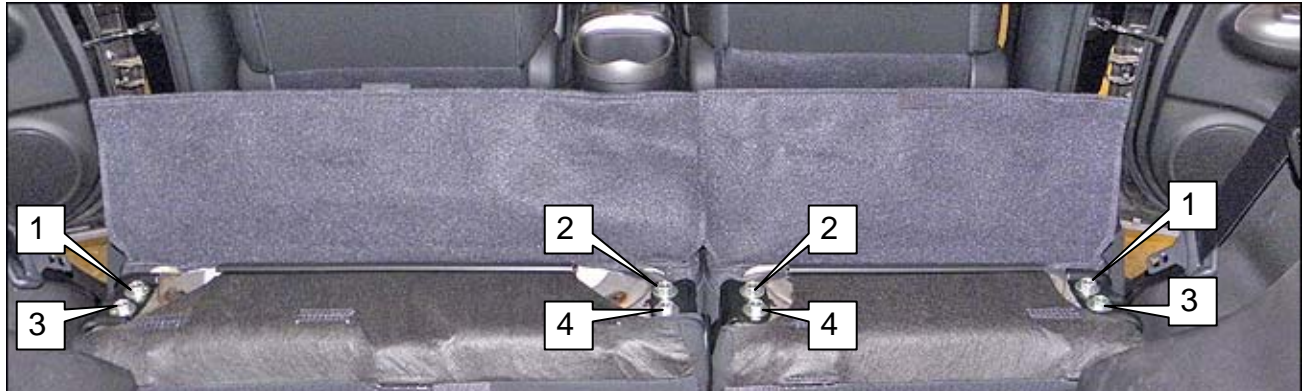

Figure 30

f. Once the seatback is adjusted, torque the bolts as follows:

- 4 left side rear seatback bolts, tighten in the order shown:
Torque to 45 Nm (4.6 kg-m, **33 ft-lb**)
- 4 right side rear seatback bolts, tighten in the order shown:
Torque to 45 Nm (4.6 kg-m, **33 ft-lb**)

PARTS INFORMATION

| DESCRIPTION | PART NUMBER | QUANTITY |
|---|-------------|----------|
| Striker Assy. - RR Seat: Kit (includes left and right striker) | H8642-1KA1A | 1 |

CLAIMS INFORMATION

Submit a “CM” line claim using the following claims coding:

| CAMPAIGN (“CM”) I.D. | DESCRIPTION | OP CODE | FRT |
|----------------------|---|---------|---------|
| R1216 | Replace RH and LH Rear Seatback Strikers | R12161 | 1.0 hrs |