

SAFETY RECALL ACTION

To: All North America Dealers For the attention of: Service Manager/After Sales Manager Please copy to: Dealer Principal Sales Manager Warranty Administrator Aston Martin Technician(s) Parts Manager	Reference RA-03-0016V2 Issued: 23 October 2013
Model: All Models from 11 November 2007 thru 3 October 2013 but not New Vanquish or Cygnet	Page 1 of 13
VIN Range: Refer to the separately published list of VINs	
Subject: Throttle Pedal Lever - Incorrect Material Specification and Adjustment of the Footwell Scuff-Plate on Left Hand Steering Vehicles	

Reason for Version 2 of this Safety Recall Action (RA-03-0016).

The list of affected VINs has been expanded to cover a longer time period and the footwell scuff-plate adjustment on left-hand steer vehicles has been added. Changes to this document have a black line against them in the left margin. Please destroy all copies of RA-03-0016 that you have and replace them with this Safety Recall Action **RA-03-0016V2**.

Attached Documents:

1. **Appendix A - Table that Shows the Quantities of Affected Vehicles**
2. **Copy of the Owner Notification letter for vehicles not in RA-03-0016**
3. **Copy of the Owner Notification letter for vehicles in RA-03-0016**
4. **Copy of the Change of Keeper or Address form.**

Reason for this Recall Action (RA-03-0016V2) which supersedes RA-03-0016

Aston Martin has determined that a defect which relates to motor vehicle safety exists on a quantity of vehicles that we manufactured from 11 November 2007 thru 3 October 2013. It is possible that the throttle pedal lever on these vehicles can fracture. This is because the material that the lever is made from is not to the design specification. On some left-hand steering vehicles, there can also be a problem with the position of the footwell scuff-plate. If the throttle lever fractures, the throttle will return to the idle position. Loss of function and the inability to influence or maintain engine speed above idle speed will occur.

This Recall Action is applicable to the vehicles that follow:

- Right-Hand Steering vehicles from 14 May 2012 thru 3 October 2013
- Left-Hand Steering vehicles from 11 November 2007 thru 3 October 2013

Model	Body Type
DB9	Coupe and Volante
DBS	Coupe and Volante
Virage	Coupe and Volante
Rapide and Rapide S	Coupe
V12 Vantage	Coupe
V8 Vantage and V8 Vantage S	Coupe and Roadster

As a precaution the procedures that follow must be done to every vehicle that is in the separately published list of VINs:

- Change the throttle pedal assembly,
- On Left-Hand steer vehicles, examine and if necessary adjust the position of the footwell scuff-plate.

Note: *All vehicles that have had the throttle pedal replaced by the initial issue of this Recall Action (RA-03-0016) must have the throttle pedal replaced again by this Recall Action.*

PLEASE DO A CHECK OF ALL VEHICLES THAT ARE IN THE AFFECTED VIN LIST

Legal Requirements

The National Traffic and Motor Vehicle Safety Act, as amended, provides that each vehicle which is subject to a recall campaign of this type must be adequately repaired within a reasonable time after the owner has tendered it for repair. Failure to repair within sixty (60) days after tender of a vehicle is prima facie evidence of failure to repair within a reasonable time.

If the condition is not adequately repaired within a reasonable time, the owner may be entitled to an identical or reasonable equivalent vehicle at no charge, or to a refund of the purchase price less a reasonable allowance for depreciation.

To avoid having to provide these difficult solutions, every effort must be made to promptly schedule an appointment with each owner and to repair their vehicle as soon as possible. As you will see in reading the attached copies of the letters that are being sent to Owners, the Owners are being instructed to contact Aston Martin Customer Service if their Dealer does not correct the condition within three (3) days of the mutually agreed upon service date. If the condition is not corrected within a reasonable time, they are instructed on how to contact the National Highway Traffic Safety Administration.

IMPORTANT: Some of the involved vehicles may still be in your Dealer inventory. Federal law requires you to complete the recall service on these vehicles before retail delivery.

Communications

Because of the quantity of vehicles that are affected by this problem, please write to every owner directly to tell them about this Safety Recall Action. There are two Customer letters. The first letter must be sent to Owners whose vehicle was in the initial recall. We have called these Customers "Recall Population A". The second letter must be sent to the Owners of vehicles that were not part of the initial recall (RA-03-0016). We have called these Customers "Recall Population B". Copies of the letters are attached at the end of this Recall Action for you to copy. There is also a copy of the "Change of Keeper's Address or Ownership" form. Please include a copy of this with each Owner's letter. When you send the letter to the Owner, you must:

- Make sure that the full 17 digit VIN Number is in the introduction of the letter.
- Clearly mark the envelope "SAFETY RECALL NOTICE" in capital letters and large type that is different from the Owner's address.
- Send the notification letter by first-class post.

When the Owner calls to make an appointment, briefly describe the remedial work which will be done to the Owner's vehicle. Tell the owner that the repair will be done at no cost to them. To claim for your administration and stationary and administration costs, refer to "Warranty Data" at the end of this procedure.

Service Reception Desk – Checks you must do before you book the vehicle in.

Before you start work, log on to the Online Dealer Warranty (ODW) system. Do the steps that follow:

1. Select the Warranty Live screen (Outstanding Campaigns Status).
2. Use the VIN list in Appendix "A" to do a check of the VINs in your control.

3. Find out if there are other open Service Actions (SAs) or Recall Actions (RAs) for the vehicles in the list.
4. List the SAs and RAs and plan the work so that the Owner only needs to come to your Dealership once.

Note: *The ODW system operates in real-time. Thus, the online condition shows only the newest Dealer Warranty Claim submissions.*

This Safety Recall Action Includes the Sections That Follow:

- Workshop Procedure
 - Part 1 - Change the throttle pedal assembly (all vehicles)
 - Part 2 - Do a check of the throttle pedal movement (all left-hand steer vehicles)
 - Part 3 - If necessary, adjust the footwell scuff-plate (left-hand steer vehicles only)
- Examples of the Owner letters
- An example of the Change of Keeper or Address form.

Workshop Procedure

Part 1 - Change the throttle pedal assembly (all vehicles)

1. Remove the throttle pedal assembly (refer to the Workshop Manual procedure 03.18.AB).
2. Remove the two nuts and Torx screws that attach the pad to the pedal assembly.
3. Put the pad in position on the new throttle pedal assembly.
4. Install and tighten the two nuts and two Torx screws that attach the pad.
5. Install the new throttle pedal assembly (refer to the Workshop Manual procedure 03.18.AB).
6. Make the old throttle pedal assembly unserviceable so that it cannot be used again.

Part 2 - Do a check of the throttle pedal movement (all Left-Hand Steer vehicles)

7. Connect the AMDS to the vehicle.
8. Go to data monitor on AMDS and select PID_309D4: "Relative throttle pedal angle in % (0-100%)" (1) (refer to Figure 1). The PID will be added to the bottom table.
9. Click on "Add" (2).
10. Click on "Close" (3).

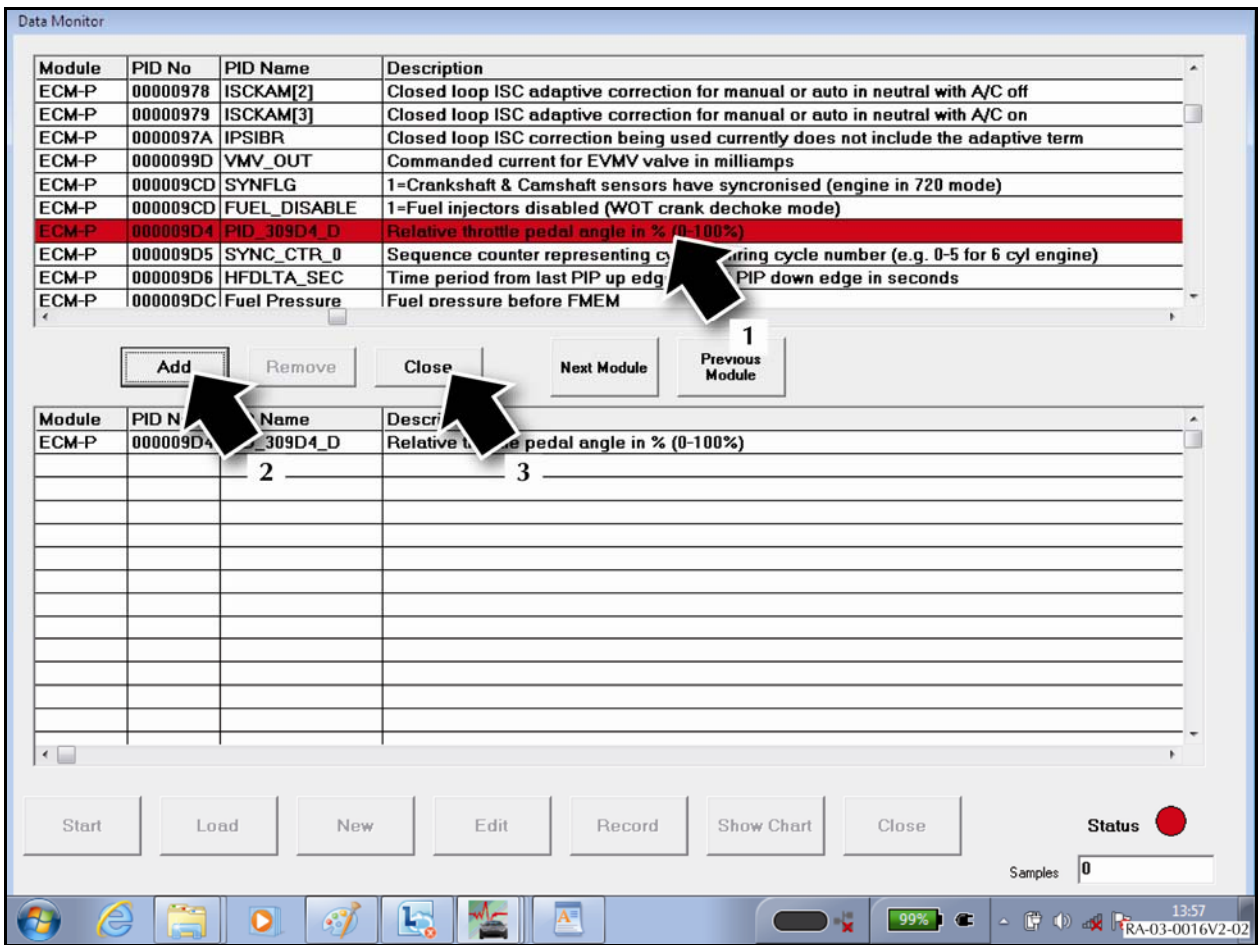

Figure 1

11. The throttle pedal angle screen will be shown (refer to Figure 2).
12. Click on "Start" (1). When you move the throttle pedal, the percentage of the angle of movement will be shown in the "value" cell (2).

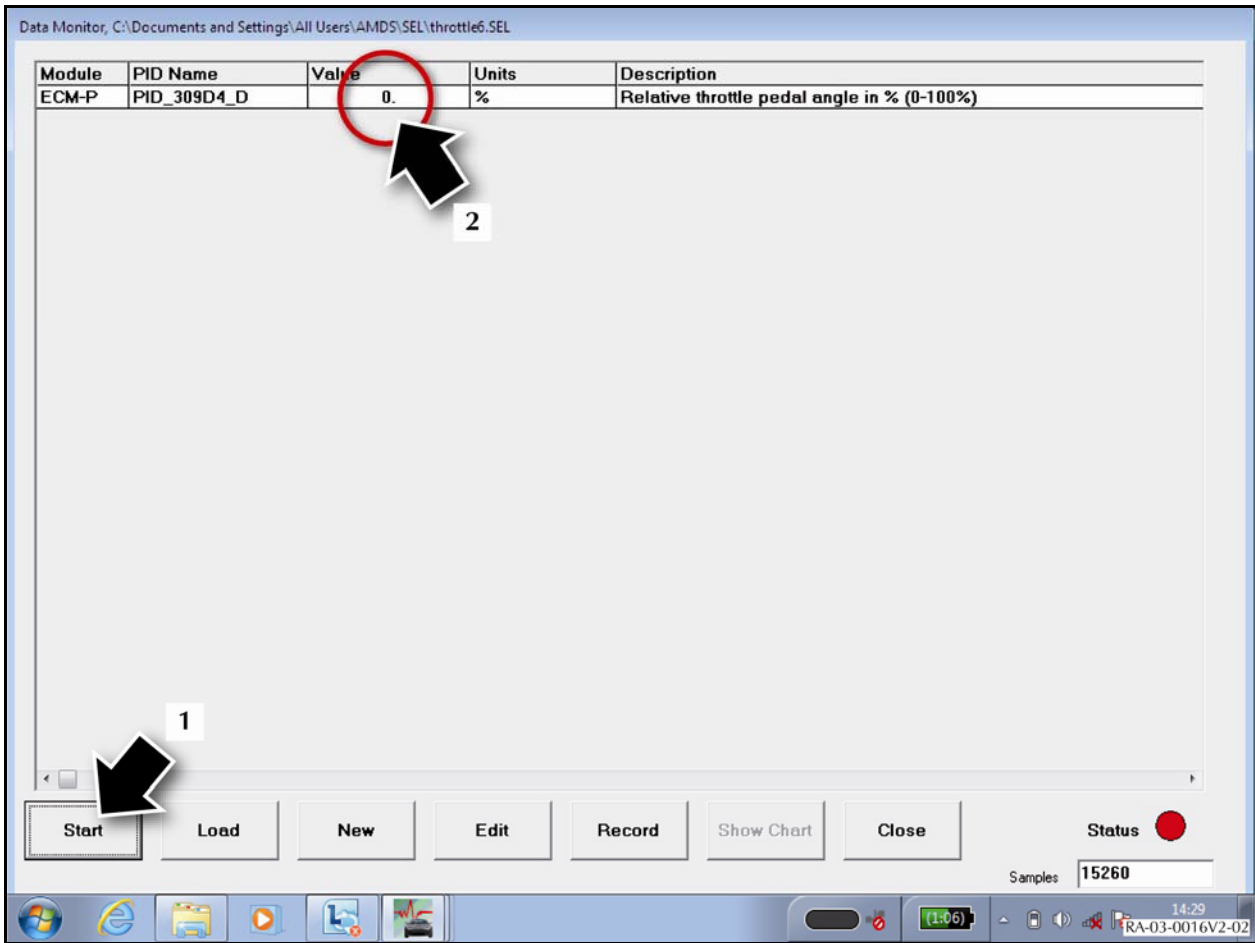

Figure 2

13. Use your hand **only** to fully push the throttle pedal down.
14. Use the AMDS to do a check of the percentage of travel of the throttle pedal. The pedal travel must be **98 percent** or higher.
15. If the pedal does not have the necessary movement, do Part 3 of this procedure that follows:

Part 3 - If necessary, adjust the footwell scuff-plate (Left-Hand Steer vehicles only)

16. On vehicles with B and O audio, do steps 17 thru 19 that follow:
17. Remove the two screws that attach the grille for the driver's side front footwell speaker (footwell speaker) to the bracket (refer to Figure 3).

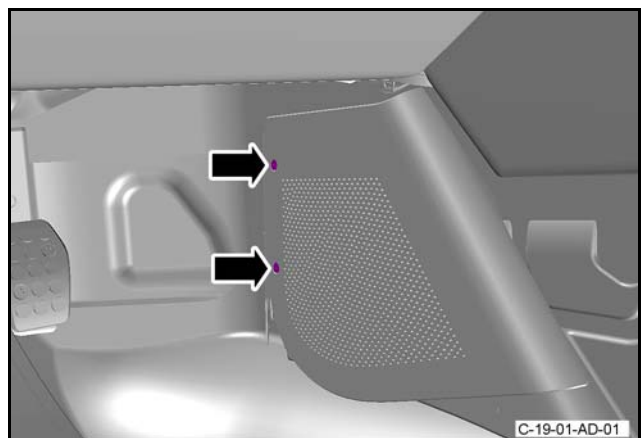

Figure 3

- 18. Release the grille for the footwell speaker from the two tabs that attach it to the footwell speaker and remove the grille (refer to Figure 4).

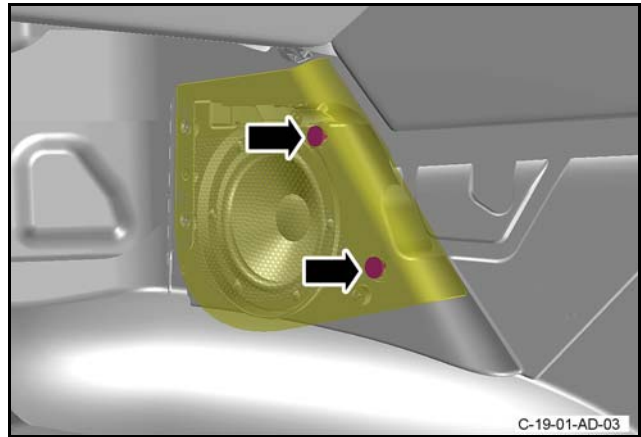

Figure 4

- 19. Remove the screw that attaches the bracket to the footwell speaker and remove the bracket. (refer to Figure 5).

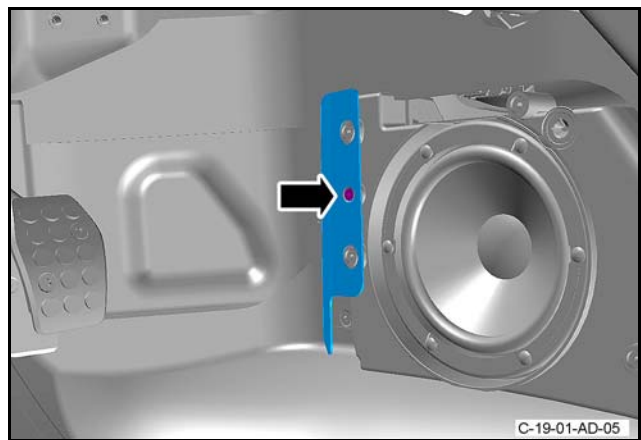

Figure 5

- 20. On all vehicles, remove the four screws that attach the accelerator scuff-plate (scuff-plate) to the body and remove the scuff-plate (Figure 6).

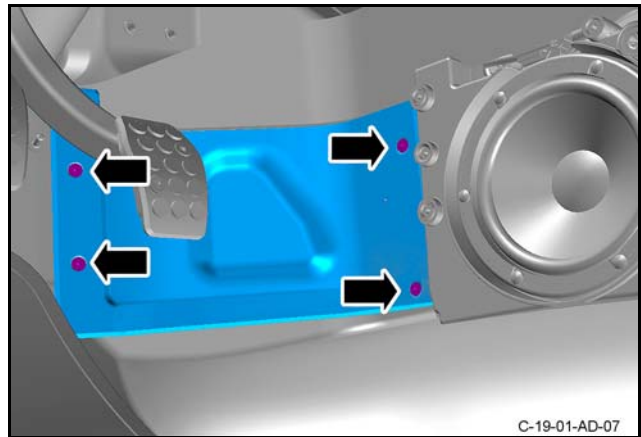

Figure 6

- 21. On vehicles with B and O audio, do steps 22 thru 24 that follow:

- 22. Move the side tunnel carpet away from the front footwell speaker (refer to Figure 7).

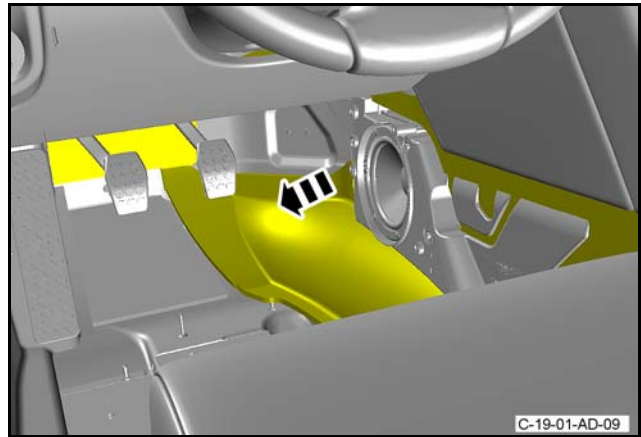

Figure 7

- 23. Disconnect the electrical connector from the footwell speaker (refer to Figure 8).

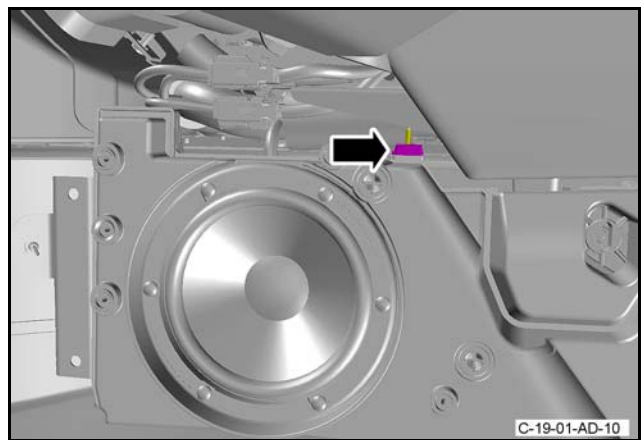

Figure 8

- 24. Remove the two screws that attach the footwell speaker to the body and remove the footwell speaker (refer to Figure 9).

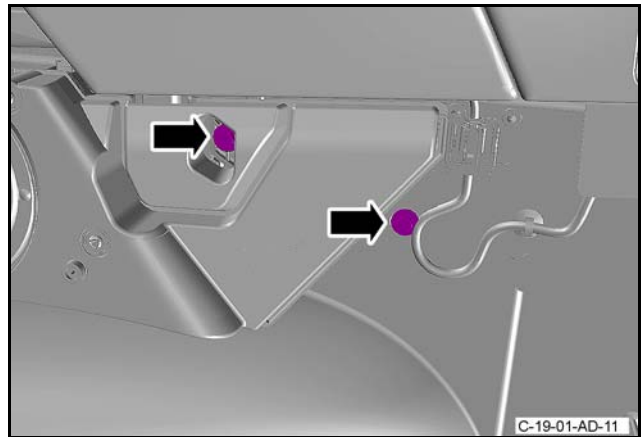

Figure 9

- 25. Cut and remove the piece of carpet that is above the position for the scuff plate (refer to Figure 10). Discard the removed carpet.

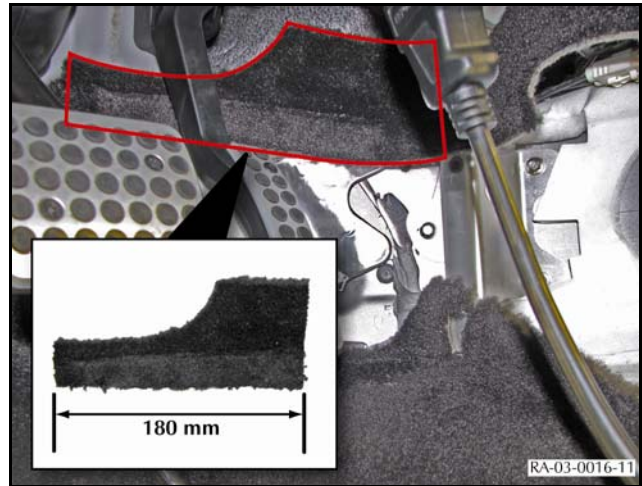

Figure 10

- 26. Cut and remove the piece of insulation (1) that is above the position for the scuff-plate, shown in Figure 11. Discard the removed insulation.



Figure 11

- 27. Loosen, but do not remove the three screws (1) that attach the bracket for the scuff plate (2) to the body (refer to Figure 12).
- 28. Move the bracket (2) fully towards the front of the vehicle (3).
- 29. Tighten the three screws (1) that attach the bracket (2).

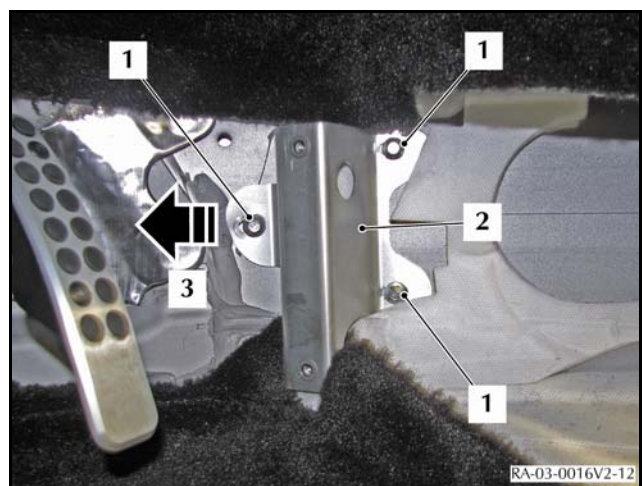

Figure 12

- 30. Make sure that there is no NVH material (1) on the body where the scuff plate is attached. Remove all NVH material (1) from this area (refer to the example shown coloured green in Figure 13).



Figure 13

- 31. Use a piece of double-sided adhesive carpet tape approximately 50 mm square (1) to attach the loose end of the carpet to the tunnel (2) (refer to Figure 14).

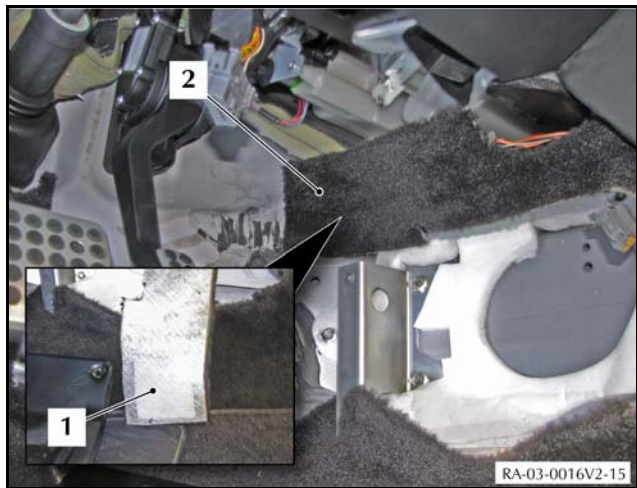

Figure 14

- 32. On vehicles that have B and O audio, do steps 33 thru 35 that follow:

- 33. Put the footwell speaker in position (refer to Figure 15).

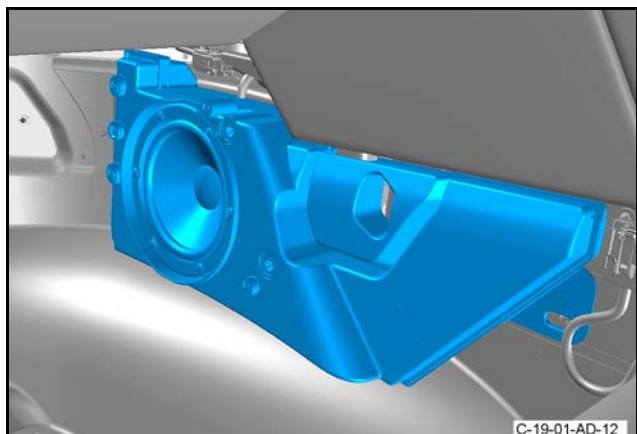

Figure 15

- 34. Install the two screws that attach the footwell speaker (refer to Figure 16).

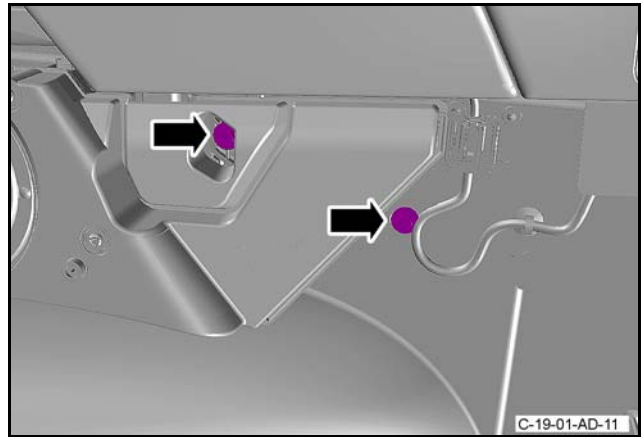

Figure 16

- 35. Connect the electrical connector to the footwell speaker (refer to Figure 17).

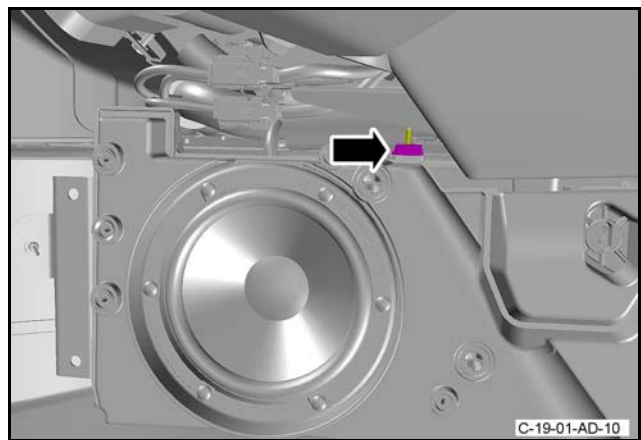

Figure 17

- 36. On all vehicles, put the scuff-plate into position (refer to Figure 18).
- 37. Install and tighten the four screws that attach the scuff-plate.

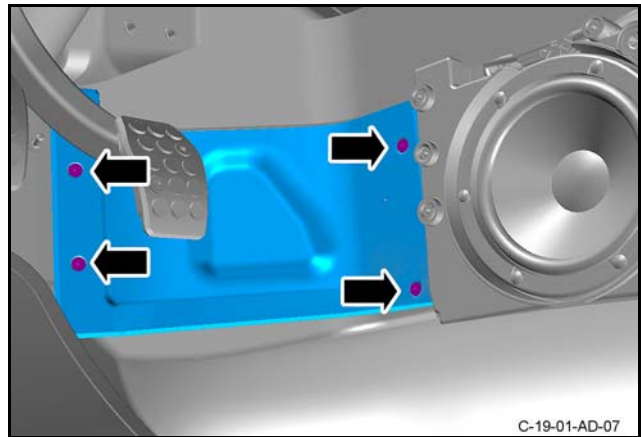

Figure 18

38. On vehicles that have B and O audio, do steps 38 thru 42 that follow:

39. Put the bracket in position at the front of the footwell speaker (refer to Figure 19).

40. Install the screw that attaches the bracket to the footwell speaker.

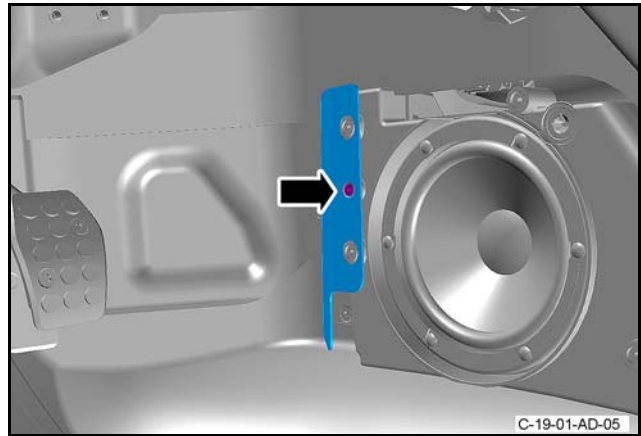

Figure 19

41. Engage the two tabs on the grille for the footwell speaker that attach it to the footwell speaker and attach the grille (refer to Figure 20).

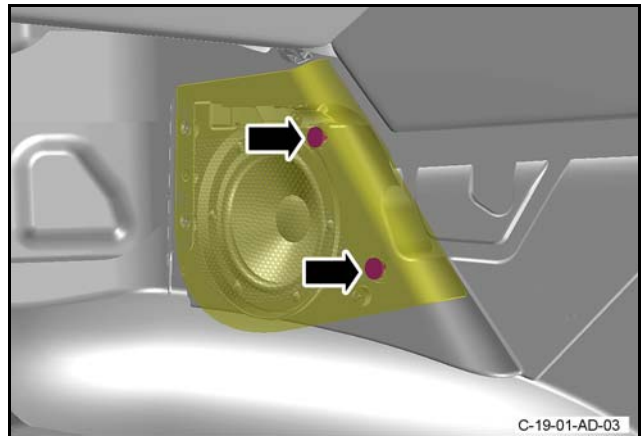

Figure 20

42. Install and tighten the two screws that attach the grille to the footwell speaker (refer to Figure 21).

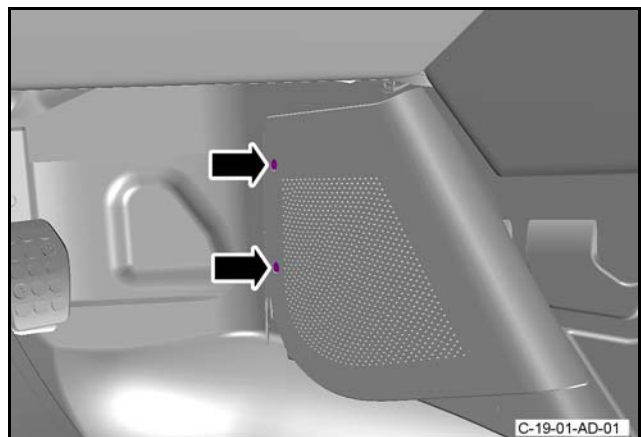

Figure 21

43. Do steps 12 thru 14 of Part 2 of this Workshop Procedure again to do a check of the throttle pedal movement. If the pedal does not have a minimum of **98 percent** movement, please speak to AMTech.

Warranty Data

Make sure that you submit your claim promptly after the work is completed. The records of your claims are used in the reporting process for the Recall Action that Aston Martin need to submit to the National Highway Traffic Safety Administration.

There are eight tiers in the Warranty database. Please make sure that you refer to the correct tier when you make the claim.

Description	Model	Time	Tier
Right-Hand Steer, Replace the Throttle Pedal Assembly	V8, V12 Vantage and Vantage S	0.20 hours	A
	DB9, Virage, DBS, Rapide and Rapide S	0.25 hours	B
Left-Hand Steer, Pedal Replace and do a check of pedal movement	V8, V12 Vantage and Vantage S	0.40 hours	C
	DB9, Virage, DBS, Rapide and Rapide S	0.45 hours	D
Left-Hand Steer, Pedal Replace, do a check of pedal movement and adjust scuff plate position (non-B&O audio)	V8, V12 Vantage and Vantage S	0.65 hours	E
	DB9, Virage, DBS, Rapide and Rapide S	0.70 hours	F
Left-Hand Steer, Pedal Replace, do a check of pedal movement and adjust scuff plate position (B&O audio)	V8, V12 Vantage and Vantage S	0.80 hours	G
	DB9, Virage, DBS, Rapide and Rapide S	0.85 hours	H

Description	Warranty Category	Sundry Code	Quantity
Administration and Stationary Costs	Consumables	ZZZ001	1

When you make the claim for the Administration cost, enter the data as shown below in "SUNDRY COSTS":

Note: You can claim 3.00 GBP or the value in your Parts Account Currency equivalent.

Claim Details

LABOUR

MT	Labour Code	Labour Description	Time
<input type="checkbox"/>	<input type="text"/>		<input type="text"/>
<input type="checkbox"/>	<input type="text"/>		<input type="text"/>
<input type="checkbox"/>	<input type="text"/>		<input type="text"/>
<input type="checkbox"/>	<input type="text"/>		<input type="text"/>

SUNDRY COSTS [Click HERE for exchange rates](#)

Sundry Code	Description	Value	Invoice No
ZZZ001 - Consumables	Admin Cost	3.00	1
Please Select	<input type="text"/>	<input type="text"/>	<input type="text"/>
Please Select	<input type="text"/>	<input type="text"/>	<input type="text"/>
Please Select	<input type="text"/>	<input type="text"/>	<input type="text"/>

Part Data

Model	Description	Part Number	Quantity
DB9 (05-12MY) (Coupe and Volante) DB9 (13MY) (Coupe and Volante) DBS (Coupe and Volante) V8 Vantage (and S) (Coupe and Roadster) V12 Vantage (Coupe) Virage (Coupe and Volante) Rapide (and Rapide S)	Pedal Assy, Throttle (does not include pad)	8D33-9N734-AB	1

Appendix A - Table that Shows the Quantities of Affected Vehicles

Please refer to the list that is published on DCS for the full VIN List. On DCS select "**Dealer Support**", click on "**After Sales**", then "**Next>>>**", then click on "**General Documentation**" and click on "**RA-03-0016V2 and QN-03-0017V2 VINs**".

Note: Please refer to the list on DCS for the vehicles in your region.

Model	Registered & AMLNA Fleet	Port & Dealer Not Registered	Build Range (MM/YY)
DB9 Coupe	424	37	12/07-10/13
DB9 Volante	502	70	11/07-10/13
DBS Coupe	456	1	11/07-10/13
DBS Volante	203	1	05/09-10/13
Virage Coupe	120	0	01/11-08/12
Virage Volante	156	0	01/11-08/12
V8 Vantage Coupe	810	59	11/07-10/13
V8 Vantage Roadster	697	60	11/07-10/13
V8 Vantage S Coupe	161	17	11/10-10/13
V8 Vantage S Roadster	122	12	11/10-10/13
V12 Vantage Coupe	191	4	06/10-10/13
Rapide	644	0	02/10-12/12
Rapide S	82	75	10/12-10/13
TOTAL	4568	336	

If you have any questions related to this Recall Action, please contact: Aston Martin Technical Services on:
+44 (0) 1926 644720 or facsimile: +44 (0) 1926 644733.
E-mail: amtech@astonmartin.com. Or contact your After Sales Manager.

This Recall Action is written in Simplified Technical English to ASD-STE100™.

**Copy of the Owner Notification letter for vehicles in RA-03-0016
(Recall Population A)**

[Date DD Month, YYYY]

[Customer Name]
[Customer Address 1]
[Customer Address 2]
[Customer City/County]
[Customer Country]

IMPORTANT SAFETY RECALL NOTICE - NHTSA Recall 13V-228

This notice applies to your vehicle: [INSERT VIN]

Dear [Customer]

Safety Recall Action RA-03-0016V2 – Throttle Pedal Lever

Incorrect throttle pedal material specification, plus adjustment to the foot well scuff plate on left-hand steering vehicles.

Second Recall Action Notice

This notice is sent to you in accordance with the requirements of the National Traffic and Motor Vehicle Safety Act.

**REASON FOR THIS SECOND RECALL ACTION THAT REPLACES AND SUPERSEDES
(RA-03-0016) PREVIOUSLY ISSUED ON 29 MAY 2013.**

Aston Martin has decided that a defect which relates to motor vehicle safety exists on a range of vehicles that were manufactured from May 2012 thru April 2013. You were previously notified of this recall in a letter dated 29 May 2013. However, because of variation in the specification and quality of the material, and additional changes to the position of the foot well scuff plate on left-hand steering vehicles, we intend to do the Safety Recall again. Even if your vehicle was already repaired in this recall campaign, it is essential that you bring your vehicle back to have the new repair completed. The models affected are

- DB9 (Coupe and Volante)
- DBS (Coupe and Volante)
 - Virage (Coupe and Volante)
 - V8 Vantage (Coupe and Roadster)
 - V8 Vantage S (Coupe and Roadster)
- Rapide
- Rapide S

It is possible that the throttle pedal lever on these vehicles can fracture in use. This is because a batch of throttle pedal levers (including the part installed or previously replaced on your car), was made using the wrong material composition specification. If the throttle lever fractures, the throttle will return to the idle position and the car will not be able to maintain its speed or to accelerate, which may increase the risk of a crash.

**Copy of the Owner Notification letter for vehicles in RA-03-0016
(Recall Population A)**

WHAT WE WILL DO

We will replace the throttle pedal assembly free of charge with a quality assured part to the correct design specification. Additionally for left-hand steering vehicles only, we will examine and if necessary, adjust the position of the foot well scuff plate.

WHAT YOU SHOULD DO

Please contact your Aston Martin dealer as soon as possible to arrange a date for the repair. Even if your car has already been repaired under Recall Action RA-03-0016, it will need to be repaired again under RA-03-0016V2 to make sure that quality assured parts to the correct design specification have been installed. This includes if necessary, a minor adjustment on LHS cars to the foot well scuff plate. Instructions for making this correction have been sent to your dealer. The labor time necessary to complete this service correction is a maximum of one hour. Please ask your dealer if you wish to know how much additional time will be needed to schedule and process your vehicle.

Your Aston Martin dealer is best equipped to obtain parts and provide the service to make sure that your vehicle is corrected as promptly as possible. If, however you take your vehicle to your dealer on the agreed service date and they do not remedy this condition on that date, or within three days, we recommend that you contact Aston Martin Customer Service by calling 1-888-923-9988.

If after contacting your dealer and Aston Martin Customer Services, you are still not able to have the safety defect remedied without charge and within a reasonable time, you may wish to write to the Administrator, National Highway Traffic Safety Administration, 1200 New Jersey Avenue, SE, Washington, DC 20590 or call 1-888-327-4236 (TTY: 1-800-424-9153) or go to <http://www.safercar.gov>.

If you have already had your vehicle repaired due to this problem before receipt of this notice, you may be entitled to reimbursement for any out of pocket costs. For further information, please contact Aston Martin Customer Service by calling 1-888-923-9988.

IF YOU NO LONGER OWN THE VEHICLE

If you have sold or traded your vehicle, please tell us by completing the enclosed Change of Keeper form and returning it to us.

Federal regulations require that any lessor receiving this recall notice must forward a copy of this notice to the lessee within ten days.

We are sorry to cause added inconvenience as a consequence of Version Two of this Recall Action. However, this action has been taken in the interest of your safety and continued satisfaction with our products.

Yours faithfully

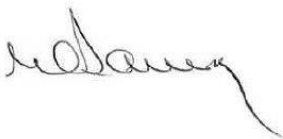

Bill Donnelly
General Manager
Global After Sales Operations
Aston Martin Lagonda Limited

**Copy of the Owner Notification letter for vehicles not in RA-03-0016
(Recall Population B)**

[Date DD Month, YYYY]

[Customer Name]
[Customer Address 1]
[Customer Address 2]
[Customer City/County]
[Customer Country]

IMPORTANT SAFETY RECALL NOTICE - NHTSA Recall 13V-228

This notice applies to your vehicle: [INSERT VIN]

Dear [Customer]

Safety Recall Action RA-03-0016V2 – Throttle Pedal Lever

Incorrect throttle pedal material specification, plus adjustment to the foot well scuff plate on LHS vehicles.

This notice is sent to you in accordance with the requirements of the National Traffic and Motor Vehicle Safety Act.

Aston Martin has decided that a defect which relates to motor vehicle safety exists on a range of vehicles that were manufactured from November 2007 thru October 2013. The models affected are:

- DB9 (Coupe and Volante)
- DBS (Coupe and Volante)
- Virage (Coupe and Volante)
- V8 Vantage (Coupe and Roadster)
- V8 Vantage S (Coupe and Roadster)
- Rapide
- Rapide S

It is possible that the throttle pedal lever on these vehicles can fracture in use. This is because a batch of throttle pedal levers (including the part installed or previously replaced during service on your car), was made using the wrong material composition specification. If the throttle lever fractures, the throttle will return to the idle position and the car will not be able to maintain its speed or to accelerate, which may increase the risk of a crash.

WHAT WE WILL DO

We will replace the throttle pedal assembly free of charge with a quality assured part to the correct design specification. Additionally for LHS cars only, we will examine and if necessary, adjust the position of the foot well scuff plate.

WHAT YOU SHOULD DO

Please contact your Aston Martin dealer as soon as possible to arrange a date for the repair. This includes if necessary, a minor adjustment on LHS cars to the foot well scuff plate. Instructions for

**Copy of the Owner Notification letter for vehicles not in RA-03-0016
(Recall Population B)**

making this correction have been sent to your dealer. The labor time necessary to complete this service correction is a maximum of one hour. Please ask your dealer if you wish to know how much additional time will be needed to schedule and process your vehicle.

Your Aston Martin dealer is best equipped to obtain parts and provide the service to make sure that your vehicle is corrected as promptly as possible. If, however you take your vehicle to your dealer on the agreed service date and they do not remedy this condition on that date, or within three days, we recommend that you contact Aston Martin Customer Service by calling 1-888-923-9988.

If after contacting your dealer and Aston Martin Customer Services, you are still not able to have the safety defect remedied without charge and within a reasonable time, you may wish to write to the Administrator, National Highway Traffic Safety Administration, 1200 New Jersey Avenue, SE, Washington, DC 20590 or call 1-888-327-4236 (TTY: 1-800-424-9153) or go to <http://www.safercar.gov>.

If you have already had your vehicle repaired due to this problem before receipt of this notice, you may be entitled to reimbursement for any out of pocket costs. For further information, please contact Aston Martin Customer Service by calling 1-888-923-9988.

IF YOU NO LONGER OWN THE VEHICLE

If you have sold or traded your vehicle, please tell us by completing the enclosed Change of Owner form and returning it to us.

Federal regulations require that any lessor receiving this recall notice must forward a copy of this notice to the lessee within ten days.

We are sorry to cause added inconvenience as a consequence of Version Two of this Recall Action, however this action has been taken in the interest of your safety and continued satisfaction with our products.

Yours faithfully

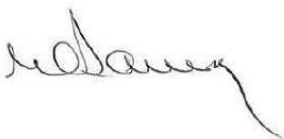

Bill Donnelly
General Manager
Global After Sales Operations
Aston Martin Lagonda Limited

Copy of the Change of Keeper or Address form



ASTON MARTIN

Recall Action RA-03-0016V2

All Models but not New Vanquish or Cygnet

Subject: Throttle Pedal Lever - Incorrect Material Specification and Adjustment of the Footwell Scuff-Plate on Left Hand Steering Vehicles

CHANGE OF KEEPER OR ADDRESS

VEHICLE IDENTIFICATION NUMBER (VIN)

REGISTRATION NUMBER (Where Known)

Please tick the applicable box:

I do not own/operate this vehicle now. The vehicle has been:

- Stolen (1)
- Scrapped (2)
- Sold/transferred to a new owner (3)
- Part exchanged at an Aston Martin dealer (4)
- Part exchanged at a non-Aston Martin Dealer (5)
- Declared an insurance write-off (6)
- Permanently exported to another country (7)
- Returned to the lease company (8)
- Sold at Auction (9)
- The address you have used is incorrect (10)

If you have ticked a box from (3) to (10), please record the latest known keeper information below:

Business Name																									
Title																									
First Name																									
Last Name																									
Address Line 1																									
Address Line 2																									
Town																									
County																									
Post Code																									
Country																									

Signature:

Date:

Please return this form by mail to: Aston Martin Lagonda, Banbury Road, Gaydon, Warwick, CV35 0DB, England.

For the attention of: After Sales Operations

Or if you prefer, you can scan and email it to amtec@astonmartin.com, or Fax it to +44 (0)1926 644733.

THANK YOU FOR YOUR CO-OPERATION