



Applies To: 2007–08 TL – Check the iN VIN status for eligibility

June 27, 2012

**Safety Recall: 2007–08 TL Power Steering Feed Hose Leak**  
(Supersedes 12-020, dated May 17, 2012, to revise the information marked by the black bars)**REVISION SUMMARY**

Under REPAIR PROCEDURE, the image for step 27 was changed.

**BACKGROUND**

Prolonged high under-hood temperature and high power steering fluid temperatures may cause the power steering hose to deteriorate prematurely and may cause the hose to crack and leak power steering fluid. Power steering fluid leaking onto a hot catalytic converter will generate smoke and could lead to an under-hood fire.

There are two bulletins that include repairs for 2007–08 TL power steering hoses:

- Service bulletin 12-020, *Safety Recall: 2007–08 TL Power Steering Feed Hose Leak*
- Service bulletin 08-016, *Safety Recall: 2004–08 TL Power Steering Feed Hose Leak*

Make sure you follow the bulletin indicated by the iN VIN status inquiry because there are different symptom codes under WARRANTY CLAIM INFORMATION. Your claim may be debited if you file a repair under the wrong bulletin.

**CLIENT NOTIFICATION**

Owners of affected vehicles have or will receive a notification of this campaign in June 2012. An example of the client notification is included at the end of this service bulletin.

Do an **iN VIN status inquiry** to make sure the vehicle is shown as eligible.

Some vehicles affected by this campaign may be in your used vehicle inventory. These vehicles must be repaired before they are sold.

Should a dealership sell an unrepaired vehicle that subsequently causes an injury or damage because of the recalled item, the dealership will be solely responsible to the damaged party, and will be required to defend and indemnify American Honda for any resulting claims. To see if a vehicle in inventory is affected by this campaign, do a VIN status inquiry before selling it.

**CORRECTIVE ACTION**

Install a power steering feed hose kit.

**PARTS INFORMATION**

Power Steering Feed Hose Kit: P/N 06535-SEP-307  
(Contains P/S feed hose, P/S pressure switch O-ring, P/S pump inlet O-ring, and all bolts, nuts, and gaskets needed for the repair.)

**REQUIRED MATERIALS**

Acura Precision Crafted Power Steering Fluid:  
P/N 08206-9002A  
(Each vehicle may need up to three 12 oz. bottles.)

**WARRANTY CLAIM INFORMATION**

Operation Number: 5121D3

Flat Rate Time: 1.7 hours

Failed Part: P/N 53713-SEP-A02

Defect Code: 5PH00

Symptom Code: S3900

Skill Level: Repair Technician

## REPAIR PROCEDURE

1. Remove the engine compartment covers shown below.

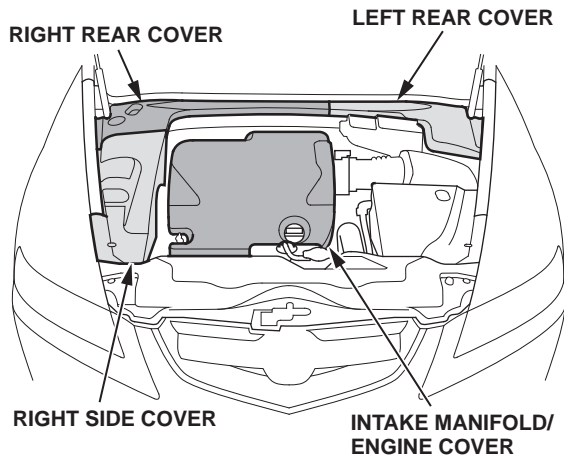

2. Drain the P/S fluid:

NOTE: Take care not to spill any fluid. Wipe off any spilled fluid immediately.

- Refer to page 17-13 of the *07-08 TL Service Manual*, or
- Online, enter keywords **STEERING FLUID**, and select **Power Steering Fluid Check/Replacement** from the list.

3. Check the condition of the drained fluid:

- If the fluid is contaminated, dark, or discolored, discard it; do not reuse it.
- If the fluid is clear with no contamination, save it in a covered container. It will be reused in step 43.

4. Reinstall the return hose on the P/S reservoir. If the hose clamp on the return hose is damaged, replace it.

5. Remove the two bolts from the under-hood fuse/relay box, then detach the fuse/relay box from the strut brace bracket.

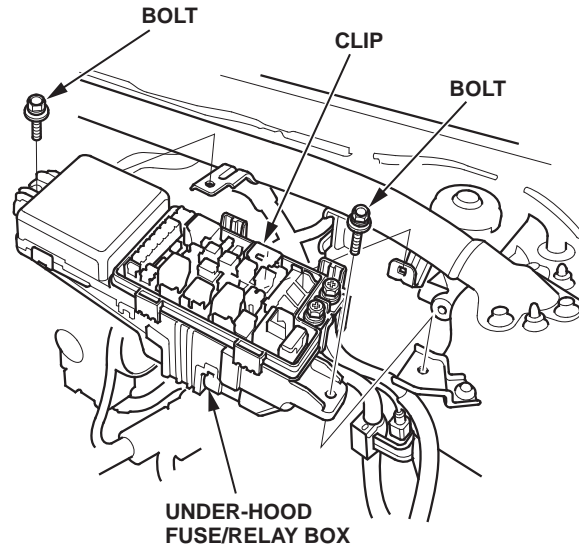

6. Remove the two bolts from the throttle cable bracket, then detach the clip from the strut brace.

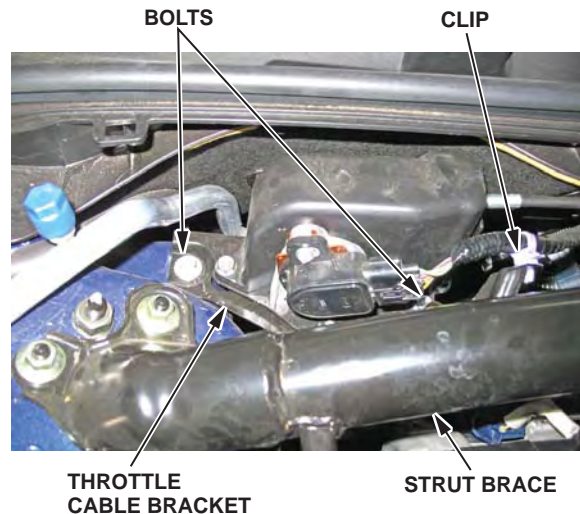

7. Remove the strut brace:
  - Remove the harness clamp.
  - Remove the two bolts.
  - Remove the six nuts.

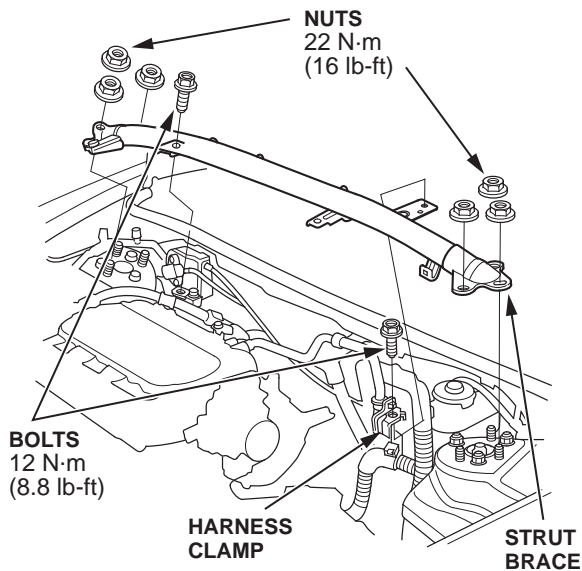

8. Disconnect the P/S feed hose from the steering gearbox by loosening its flare nut.
 

NOTE: To prevent fluid from dripping, place several shop towels under the feed hose connection, and wrap a towel around the exposed joint end.

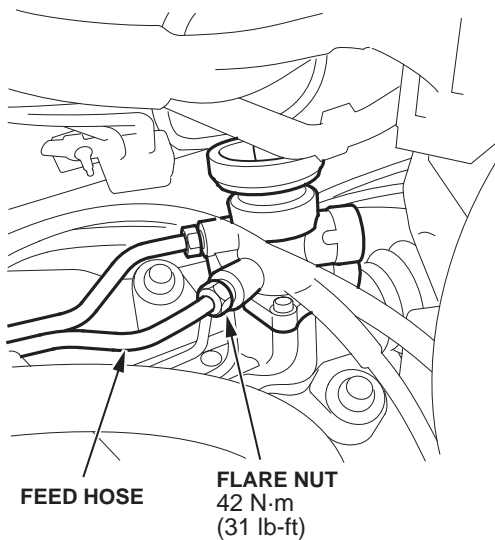

9. Remove the end of the P/S feed hose from the P/S pump.

NOTE: To prevent fluid from dripping, wrap a towel around the exposed end of the hose.

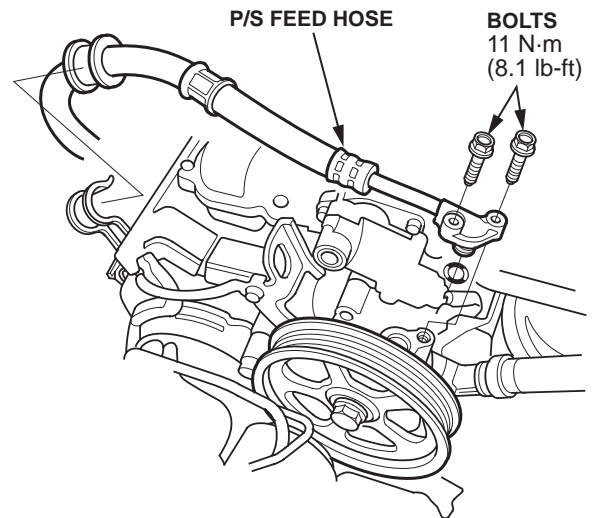

10. Replace the P/S pump inlet joint O-ring:
  - Remove the inlet joint from the pump (one bolt).
  - Remove the O-ring from the inlet joint.
  - Lubricate a new O-ring with clean P/S fluid, then install it on the end of the joint.
  - Reinstall the inlet joint, and torque its bolt to **11 N·m (8 lb-ft)**.

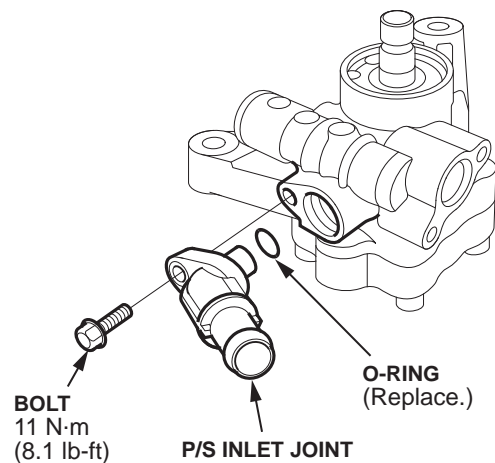

11. Remove the feed hose bracket from the rear cylinder head cover (one bolt).

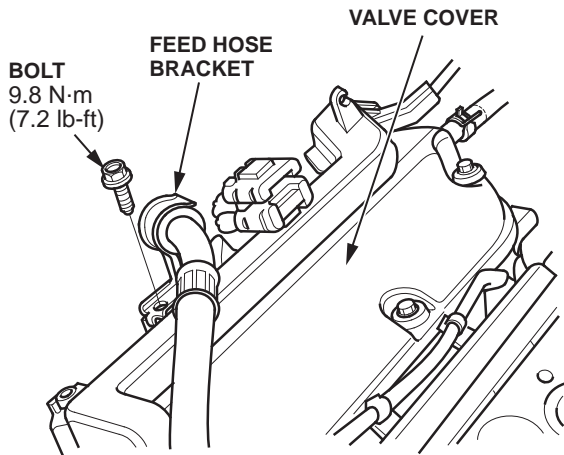

12. Disconnect the P/S pressure switch connector, then remove the pressure switch from the feed hose.

NOTE: To prevent fluid from dripping, stuff the end of a clean shop towel into the feed hose coupler.

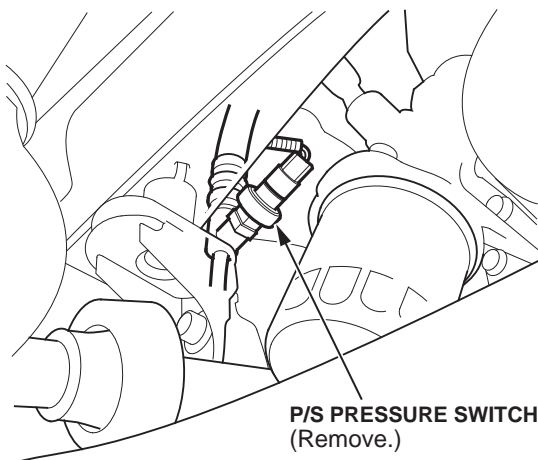

13. Remove the O-ring from the P/S pressure switch, and install a new one, lubricated with clean P/S fluid.
14. Install the original P/S pressure switch on the new feed hose. Tighten the switch to **12 N·m (8.8 lb-ft)**.

15. Remove feed hose holder B from the steering gearbox mounting bracket, located on the passenger's side (one bolt).

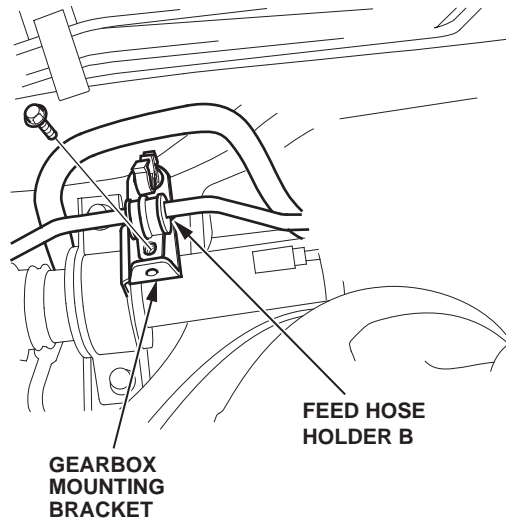

16. Remove the rear engine mount stop (two nuts), then remove the rear engine mount stop bolt. The stop bolt *will not* be reused.

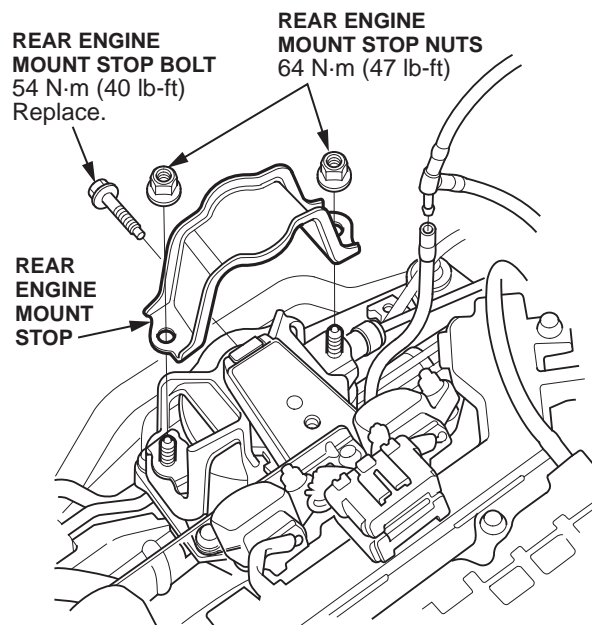

17. *M/T models only*: Remove the two bolts securing the shift cable bracket.

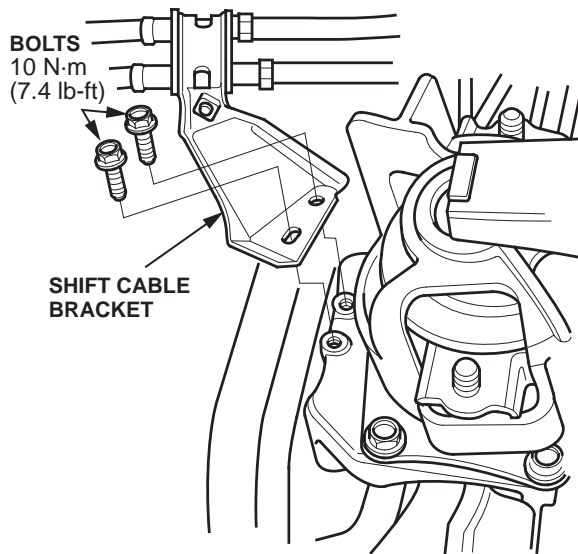

18. Lay the new feed hose next to the original feed hose in the engine compartment. Line up the hoses as closely as possible.

**NOTE:** When lining up the feed hoses, do not bend or scratch the painted metal line section of the new hose. *Even a scratch on the paint could cause future P/S line corrosion.*

19. Raise the vehicle on a lift, and make sure it's securely supported.

20. Remove the engine under cover (two bolts and four clips).

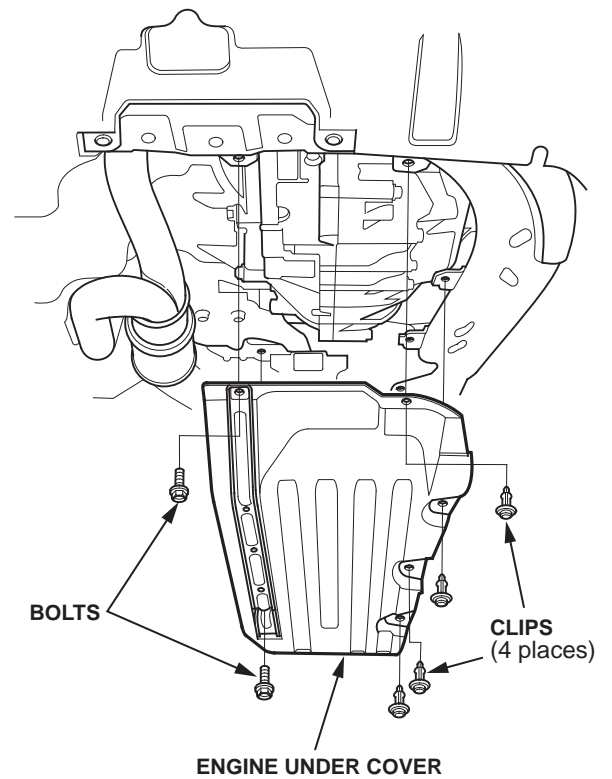



21. Remove exhaust pipe A:

- Remove the rubber exhaust hanger from the subframe.
- Remove exhaust pipe A along with the three way catalytic converter (TWC) (nine self-locking nuts). The nuts *will not* be reused.
- Support exhaust pipe B with a stand.

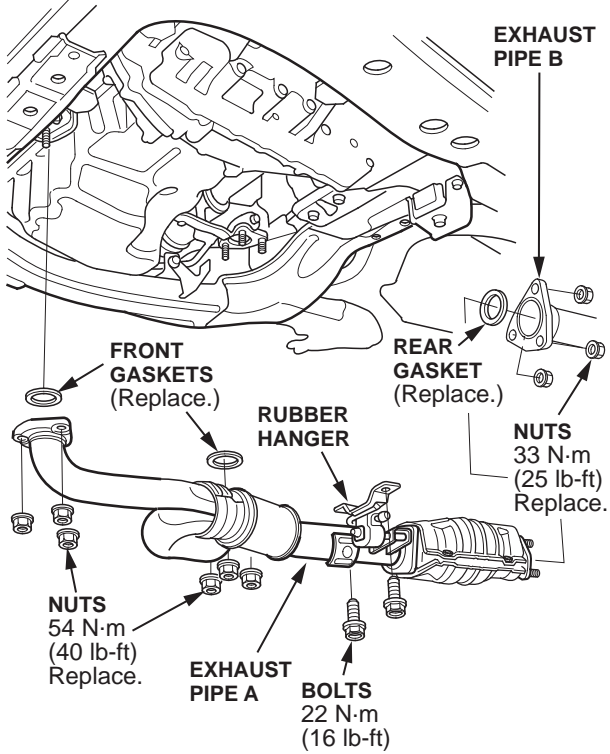

22. Remove the exhaust heat shield.

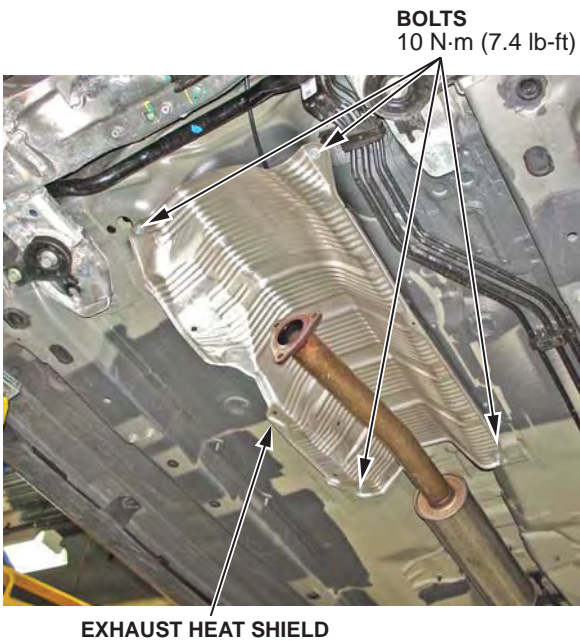

23. Remove the feed line holder from the front suspension subframe, located on the driver's side (one bolt). Remove the holder from both the feed and return lines, and discard (it will not be reused).

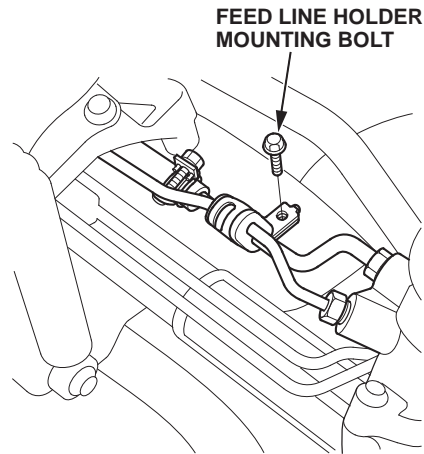

24. Remove the vacuum line bracket from the rear engine mount (one bolt).

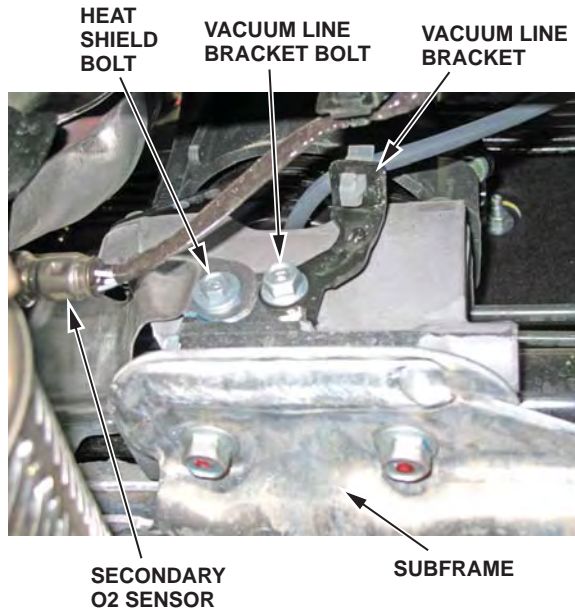

25. Remove the heat shield bolt from the front of the rear engine mount. The bolt is next to the secondary O2 sensor (bank 1, sensor 2).

26. Remove the four rear engine mount bracket bolts from the subframe. The bolts *will not* be reused.

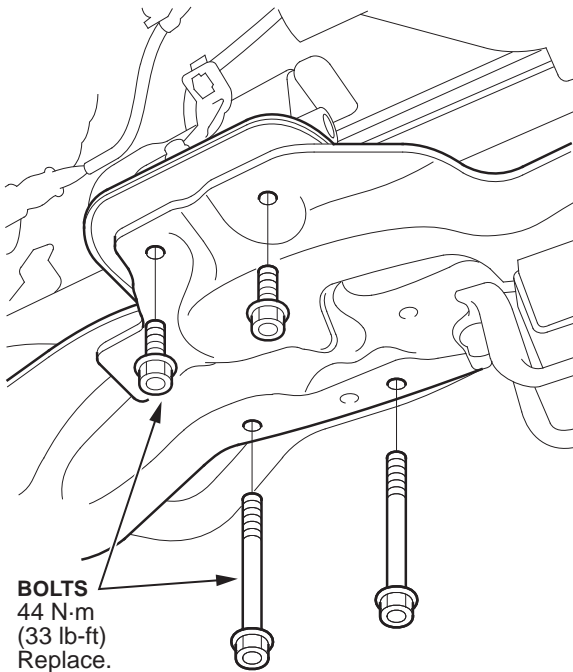

27. Remove the center bolt from the transmission lower mount:

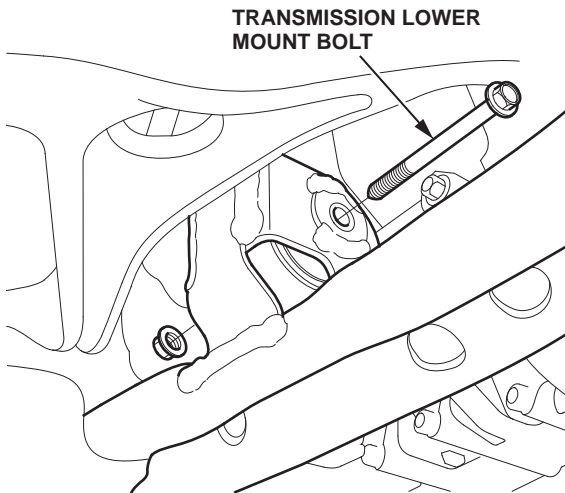

28. Using a transmission jack and a block of wood, position the wood in a secure area on the engine/transmission assembly, then *slightly* lift the assembly.

Position the wood in a secure area on the engine/transmission assembly.



**TRANSMISSION JACK STAND**

**NOTE:**

- To minimize the stress damage on the other engine/transmission mounts, do not lift the assembly too much.
- The maximum allowable lift is reached when you see the lower part of the mount's bolt hole through the bracket hole (see below).

**ORIGINAL POSITION**

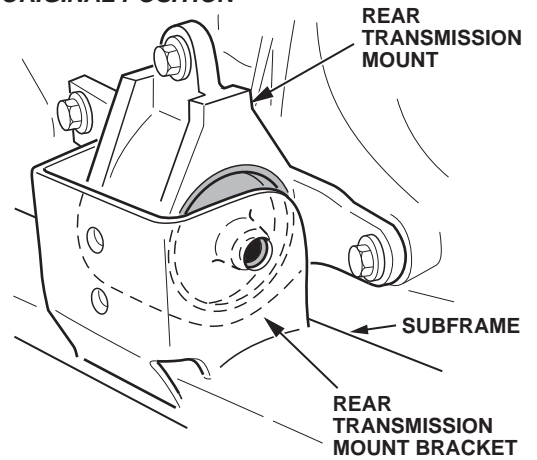

**RAISED POSITION**

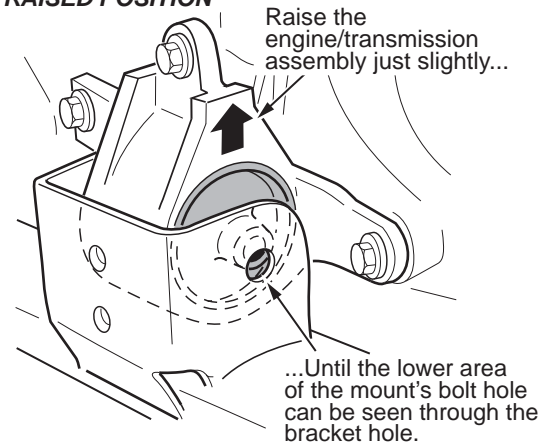

29. Shift the rear engine mount up and to the left, towards the master cylinder.
30. Swap the positions of the new hose and the original hose (previously lined up in step 18), between the rear engine mount bridge and the subframe.  
NOTE: Be careful not to bend or scratch the metal line section of the new feed hose.
31. Move the rear engine mount back into place, with the new feed hose routed through it.
32. Hand-tighten the new bolts for the rear engine mount bracket; do not torque them yet.
33. Lower the transmission jack, and remove the block of wood.
34. Reinstall the transmission lower mount center bolt, and torque it to **59 N·m (43 lb-ft)**.
35. Torque the four new rear engine mount bracket bolts to **44 N·m (33 lb-ft)**.
36. Reinstall the exhaust heat shield, and torque its bolts to **10 N·m (7.4 lb-ft)**.
37. Reattach exhaust pipe A and the TWC using new gaskets and self-locking nuts. Use the torque specs on page 5.
38. Reinstall the rubber exhaust hanger to the subframe.
39. Reinstall all other parts removed from the underside of the vehicle, then lower it.
40. Remove the original feed hose from the engine compartment, then attach the new feed hose to the gearbox and to the P/S pump:
  - Torque the gearbox flare nut on the new feed hose to **42 N·m (31 lb-ft)**.
  - Torque the P/S pump feed hose bolts to **11 N·m (8.1 lb-ft)**.

41. Install the new feed line holder (from the kit) onto the feed and return lines located on the driver's side, and then secure it to the front suspension subframe (one bolt).

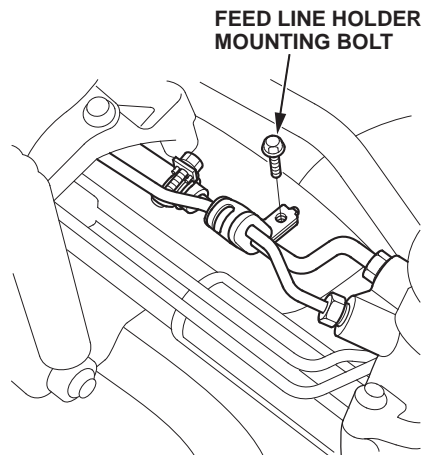

42. Reinstall all remaining removed parts except the right (passenger) side engine compartment cover. Replace any damaged trim clips.
43. Using the clear P/S fluid you removed from the system (or new fluid if the original fluid was contaminated or discolored), fill the P/S reservoir to the upper level line.  
NOTE:
  - Use Acura Precision Crafted Power Steering Fluid.
  - The system capacity is **1.1 L (37.2 oz)**.
  - The reservoir capacity is **0.32 L (10.8 oz)**.
44. Start the engine, run it at a fast idle, and turn the steering wheel lock-to-lock several times. This will bleed any air from the P/S system.
45. Recheck the fluid level, and add more if needed. Do not fill the reservoir above the upper level line.  
NOTE:
  - Make sure you remove all shop towels used during the procedure.
  - Wipe off any spilled P/S fluid.
46. Reinstall the right (passenger) side engine compartment cover.



*Example of Client Letter*

June 2012

**Safety Recall: 2007–08 TL Power Steering Feed Hose Leak - NHTSA Recall 12V-222**

Dear TL Owner:

This notice is sent to you in accordance with the requirements of the National Traffic and Motor Vehicle Safety Act.

**What is the reason for this notice?**

Acura has decided that a defect which relates to motor vehicle safety exists in certain 2007–2008 model year TL vehicles. Prolonged high under-hood temperatures and high power steering fluid temperatures may cause the power steering hose to deteriorate prematurely and may cause the hose to crack and leak power steering fluid. Fluid leaking onto a hot catalytic converter will generate smoke and possibly lead to an under-hood fire.

**What should you do?**

Call any authorized Acura dealer and make an appointment to have your vehicle repaired at no cost to you. The dealer will inspect your vehicle and replace the power steering hose. The complete repair process may take approximately one hour and 42 minutes; however, your vehicle will need to be at the dealer for a longer period of time. We recommend that you plan to leave your vehicle for half a day to allow the dealer flexibility in scheduling.

**Who to contact if you experience problems**

If you are not satisfied with the service you receive from your Acura dealer, you may write to:

American Honda Motor Co., Inc.  
Acura Client Relations  
Mail Stop 500-2N-7E  
1919 Torrance Blvd.  
Torrance, CA 90501-2746

If you believe that American Honda or the dealer has failed or is unable to remedy the defect in your vehicle, without charge, within a reasonable period of time (60 days from the date you first contact the dealer for a repair appointment), you may submit a complaint to:

Administrator  
National Highway Traffic Safety Administration  
1200 New Jersey Ave., SE  
Washington, DC 20590

You can also call the toll free Safety Hotline at 1-888-327-4236 (TTY 1-800-424-9153), or go to <http://www.safercar.gov>.

**What if you already had your vehicle repaired for this issue?**

If you previously paid to have the power steering hose replaced, you may be eligible for reimbursement. Refer to the attached Instructions for Reimbursement for the eligibility requirements and the reimbursement procedure.

**Lessor Information**

Federal law requires that any vehicle lessor receiving this recall notice must forward a copy of this notice to the lessee within 10 days.

**If you have questions**

If you have any questions about this notice, or need assistance with locating an Acura dealer, please call Acura Client Relations at 1-800-382-2238, and select option 4. You can also locate a dealer online at [Acura.com](http://Acura.com).

We apologize for any inconvenience this campaign may cause you.

Sincerely,

**American Honda Motor Co., Inc.  
Acura Automobile Division**

## Instructions for Reimbursement: Safety Recall: 2007–08 TL Power Steering Feed Hose Leak

### Reimbursement eligibility

You may be eligible for reimbursement if you previously paid to have the power steering feed hose replaced.

- You must have had your vehicle repaired before receiving this notice.
- You must have owned the vehicle at the time of repair. You are still eligible if you no longer own the vehicle.

NOTE: Any incidental expense or inconvenience you may have suffered due to the loss of use of your vehicle may not be reimbursable.

### To apply for reimbursement

- ✓ **Complete the attached Request for Reimbursement form.**
- ✓ **Attach a copy of the repair receipt or invoice for the repair.** A copy of the repair invoice from an authorized Acura dealer or independent repair facility, indicating replacement of the power steering feed hose, will meet this need. This invoice should show your vehicle's model, vehicle identification number (VIN), the name and address of the facility that did the repair, the itemized cost of the repair (parts and labor), and the date the work was completed.
- ✓ **Attach proof of payment**, such as a copy of the cancelled check, bank statement, cash receipt, or credit card receipt showing that you paid for the repair.
- ✓ **Mail this completed form and copies of the receipts and invoices to:**

**American Honda Motor Co., Inc.  
Automobile Customer Service  
P.O. Box 2964  
Torrance, CA 90509-2964**

**Please allow 6 to 8 weeks for reimbursement.**

**Failure to include proper documentation can delay your reimbursement. If you have questions, please call your local authorized Acura dealer. If they cannot help you, call 1-800-382-2238, and select option 4.**

*Fill in the following blanks. Please print clearly, and provide complete information.*

\_\_\_\_\_  
Name ( ) \_\_\_\_\_  
Daytime telephone number

\_\_\_\_\_  
Address Apt. No.

\_\_\_\_\_  
City State ZIP Code

\_\_\_\_\_  
Vehicle Identification Number (VIN) REQUIRED Mileage at time of repair \$ \_\_\_\_\_  
Total amount requested

Name of facility that did the repair \_\_\_\_\_

**Make sure to include all required supporting information with your request.**