

Reference:

ITB12-007

Date:

February 23, 2012

**VOLUNTARY SAFETY RECALL CAMPAIGN  
2003 – 2005 INFINITI Q45  
FRONT SEAT SIDE AIR BAG HARNESS CONNECTOR**

**CAMPAIGN ID#:** R1204

**APPLIED VEHICLES:** 2003 – 2005 Q45 (F50)

**NOTE: Use Service Comm to confirm campaign eligibility.**

#### INTRODUCTION

Infiniti is conducting a Voluntary Safety Recall Campaign on Model Year 2003 – 2005 Q45 vehicles to relocate and secure the seat side air bag harness connector for both front seats. This service will be performed at no charge for parts or labor.

#### IDENTIFICATION NUMBER

Infiniti has assigned identification number R1204 to this campaign. This number must appear on all communication and documentation of any nature dealing with this campaign.

#### DEALER RESPONSIBILITY

It is the dealer's responsibility to check Service Comm for the campaign status on each vehicle falling within the range of this voluntary safety recall which for any reason enters the service department. This includes vehicles purchased from private parties or presented by transient (tourist) owners and vehicles in a dealer's inventory. **Federal law requires that new vehicles in dealer inventory which are the subject of a safety recall must be corrected prior to sale. Failure to do so can result in civil penalties by the National Highway Traffic Safety Administration.** While federal law applies only to new vehicles, Infiniti strongly encourages dealers to correct any used vehicles in their inventory before they are retailed.

## SERVICE PROCEDURE

**NOTE:** Make sure to perform this repair on **both** front seats.

**IMPORTANT:** Follow all cautions, warnings, and notes in the Service Manual when working on or near a Supplemental Restraint System (SRS), such as an air bag.

1. Operate the power seat to the full REAR and the full UP positions.

**NOTE:** Driver seat is shown. The passenger seat is similar.



Figure 1

2. Write down all radio station presets.

Presets	1	2	3	4	5	6
AM						
FM-1						
FM-2						
SAT						

3. Turn ignition OFF and disconnect both battery cables (negative cable first).
4. Wait at least 3 minutes after the battery cables are disconnected.

5. Remove the front finisher from the seat.

- First pull forward,
- Then pull to the side.

**NOTE:** Driver seat is shown. The passenger seat is a mirror image of the driver seat.

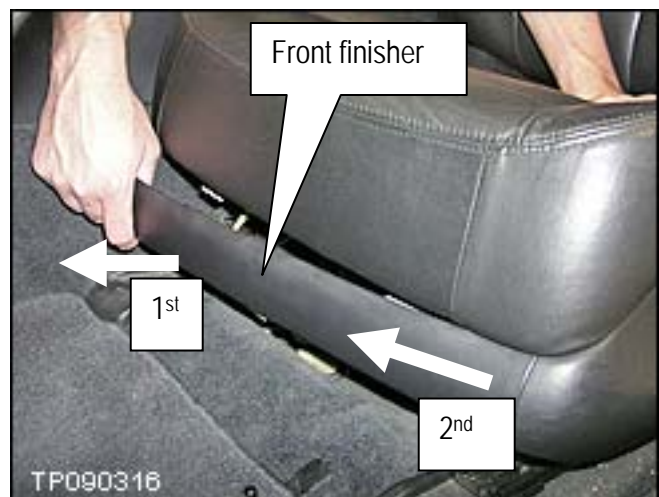

Figure 2

6. Tilt the finisher forward to expose the mounting clips for the air bag harness and connector.
7. Disconnect the mounting clips.

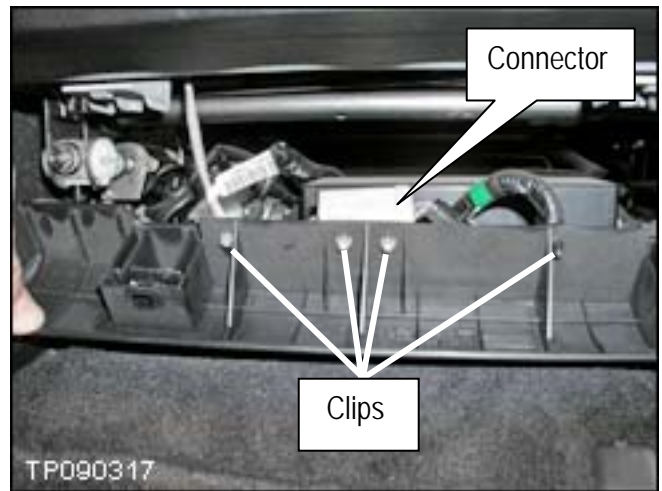

Figure 3

8. Remove the finisher from the vehicle and place it on a clean working surface.

**NOTE:** Modifications will be performed on the finisher later in the procedure.

9. Disconnect and reconnect the side air bag harness connector 3 times.

**NOTE:** This step is used to clean the connector contacts and ensure good continuity through the connector.

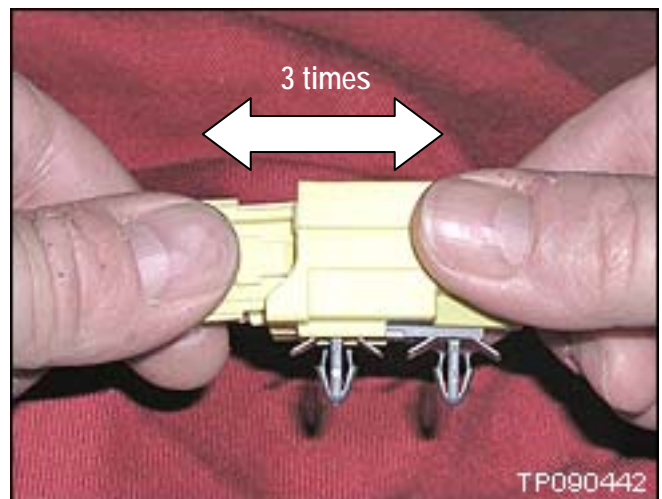

Figure 4

10. Mix a small amount (about ½ ounce) of “5 MINUTE® EPOXY” in a suitable mixing tray.

**NOTE:** See the Parts Information for product detail and MSDS information.

**CAUTION:**

- Use chemical resistant gloves when handling this product.
- Wear safety glasses with side shields.



Figure 5

11. Place covers on the floor and seat to protect against epoxy spills.

12. Apply the epoxy to the back side (wire gates) of the side air bag harness connector (see Figure 6).

- Apply epoxy to all 4 wire gates.
- Work epoxy into the wire gates.
- Apply epoxy about 5 mm wide around the wire and about 4 mm from the connector (see Figure 6).

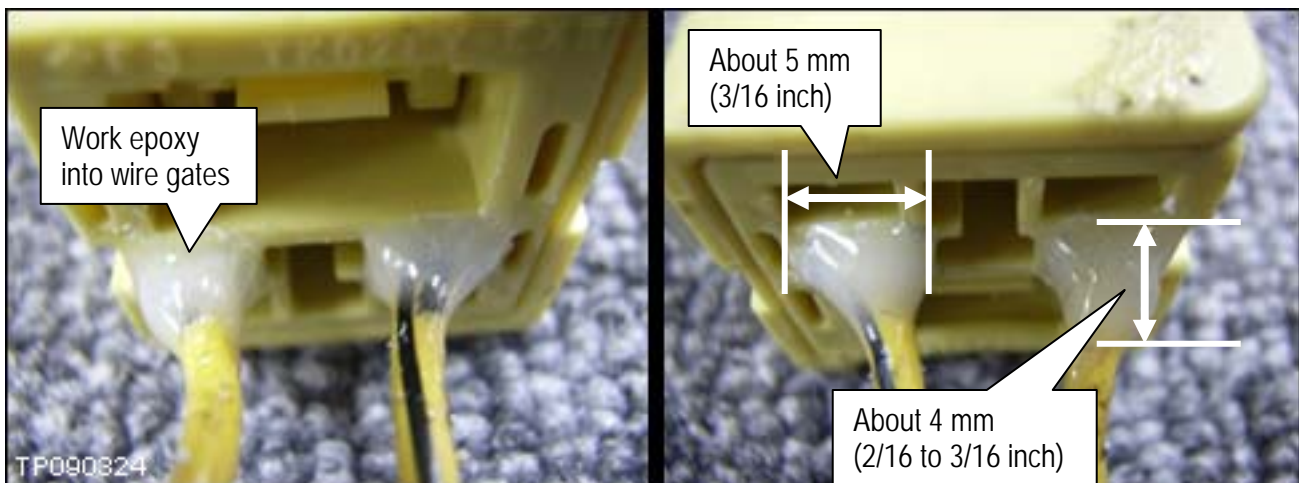

Figure 6

13. Install a tie-wrap (P/N 24216 – W1000) around the connector as shown in Figure 7.
  - a. Route the tie-wrap between the wires.
  - b. Pull the tie-wrap tight.
  - c. Cut off the excess tie-wrap.

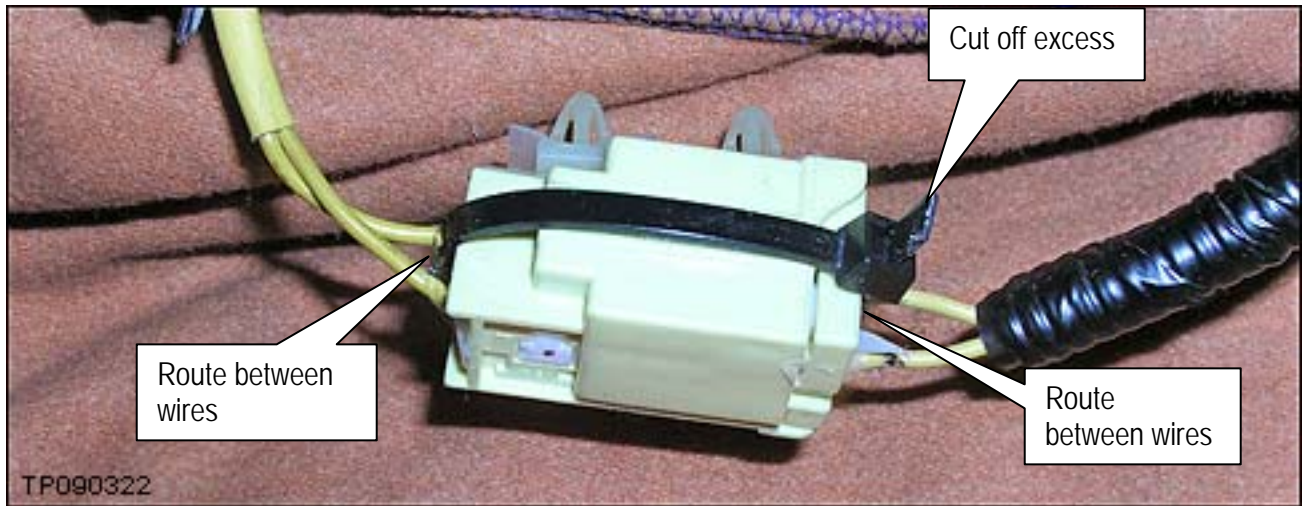

Figure 7

**NOTE:** Leave the connector undisturbed while you perform the next step. The epoxy needs to cure for 5 minutes.

14. On the back side of the finisher, cut approximately 20 mm ( $\frac{3}{4}$  inch) off of the 5 center ribs (see Figures 8, 9, and 10).

**NOTE:**

- The side air bag harness connector mounting point will be moved from the bottom of the finisher to inside the finisher.
- The ribs must be cut to allow room to mount the connector and harness clips.

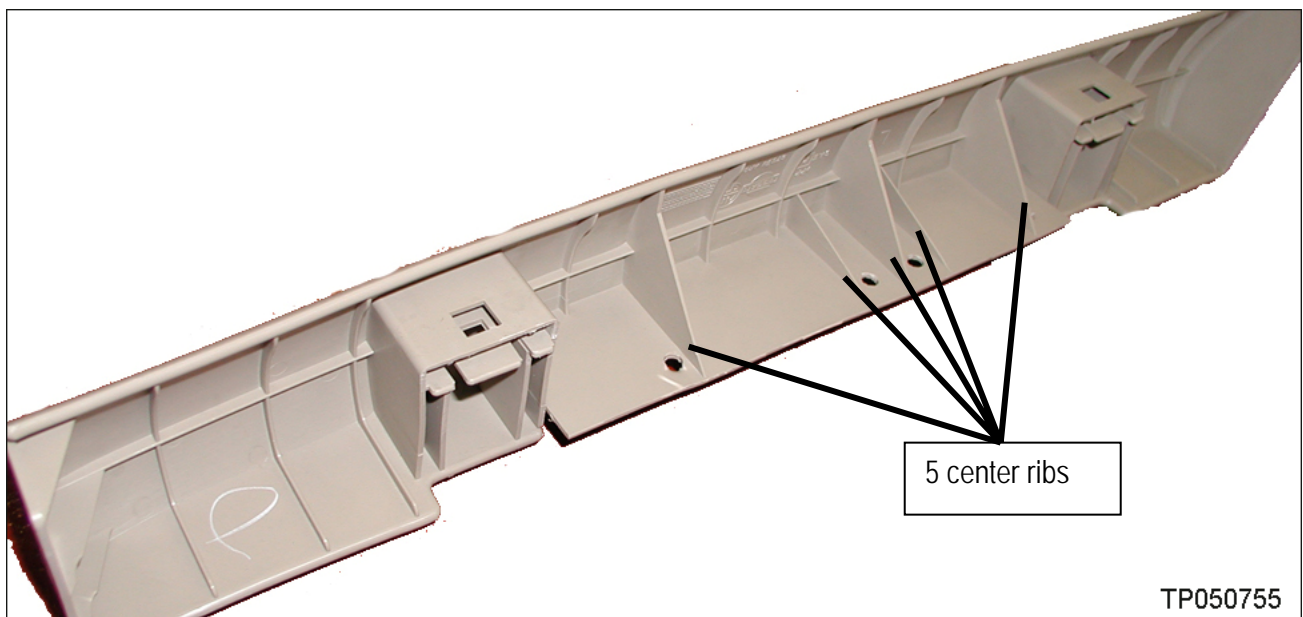

Figure 8

See next page for photos showing cut outlines and completed cuts.

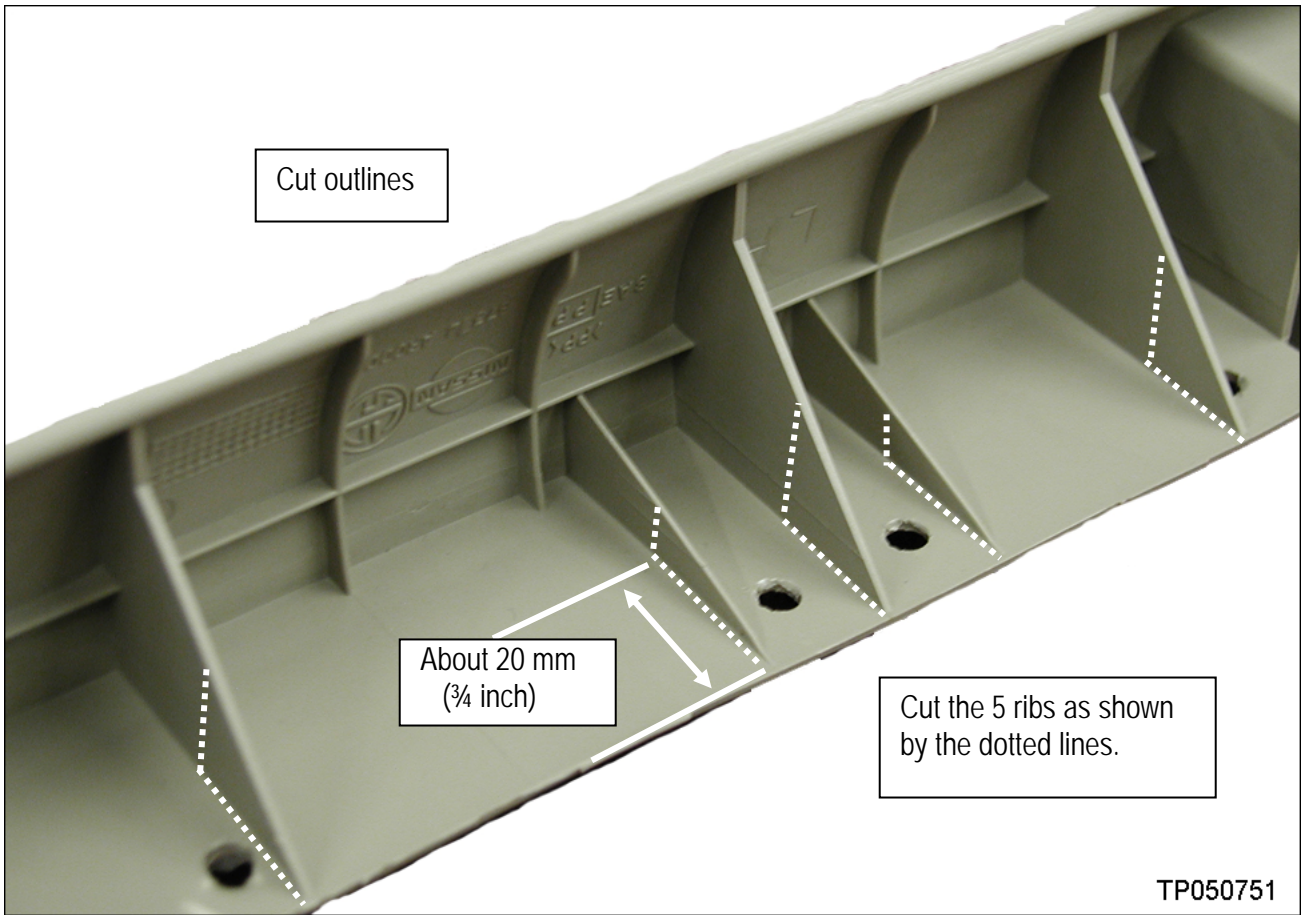

Figure 9

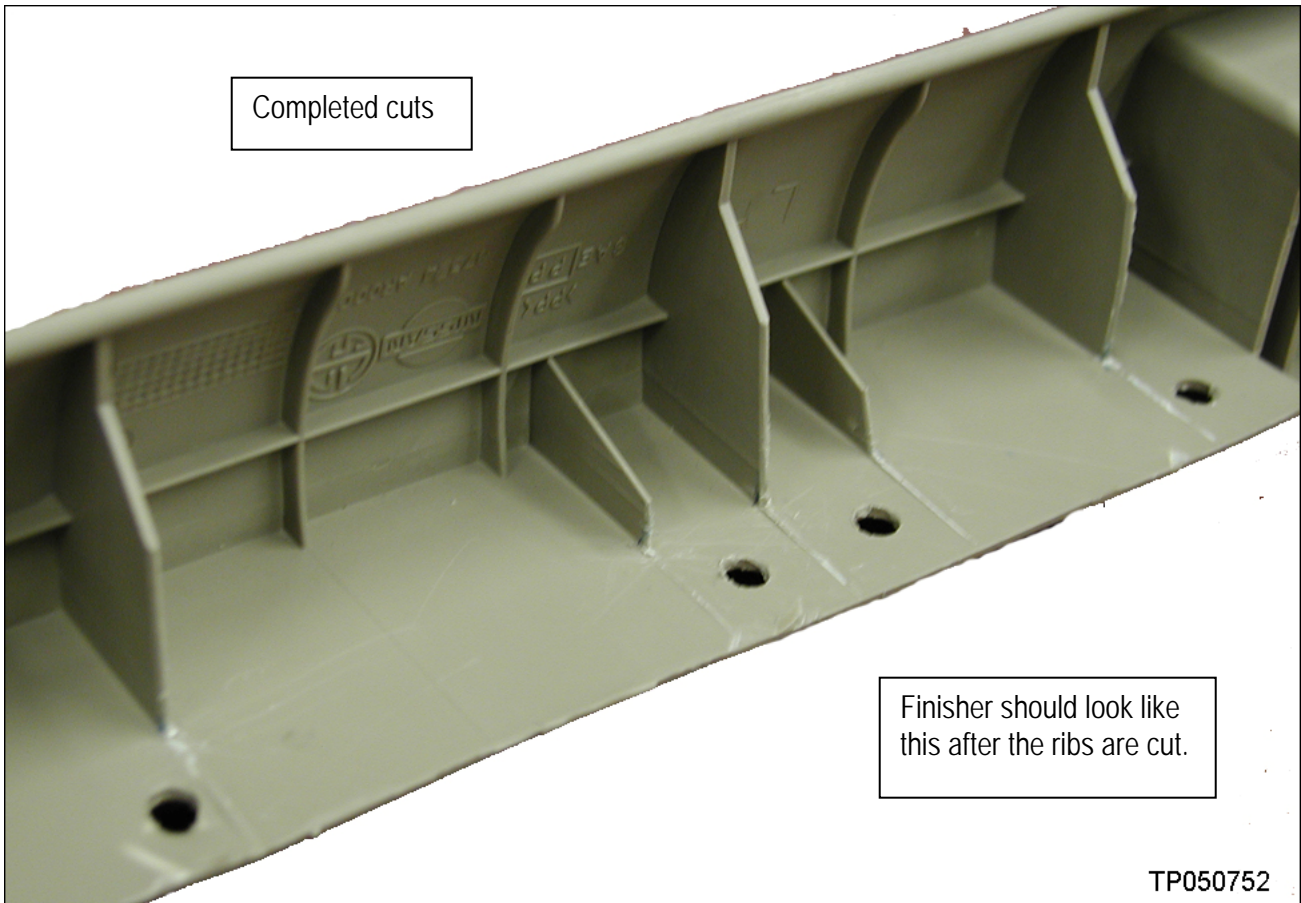

Figure 10

**NOTE:** Make sure the epoxy has cured for 5 minutes before performing the next step.

15. Attach the side air bag connector and harness clips to the front finisher as shown in Figure 11.

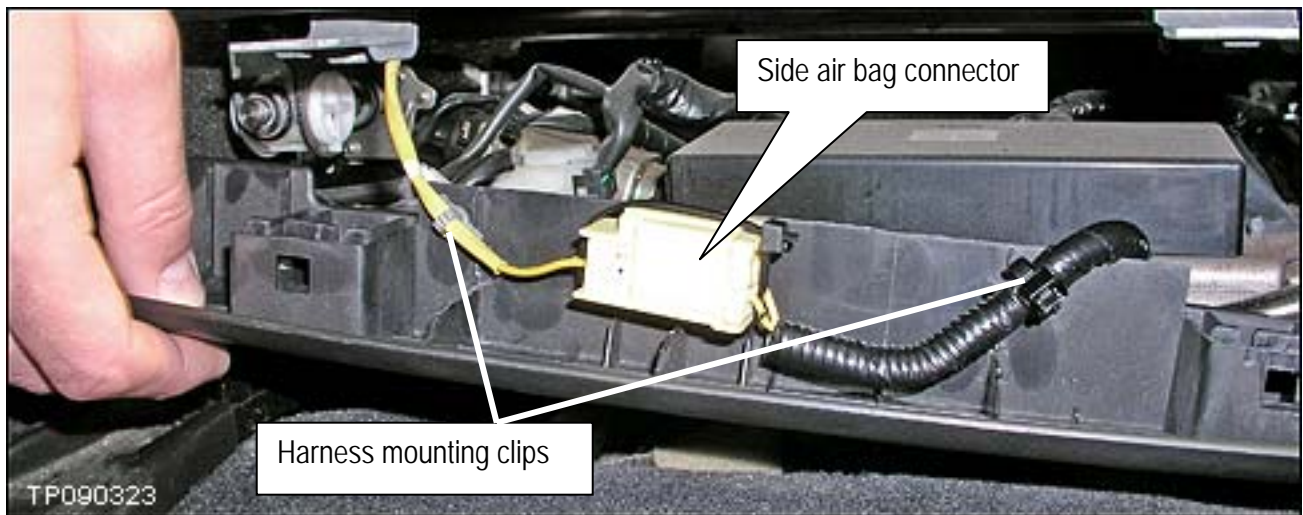

Figure 11

16. Reattach the front seat finisher in reverse order.

17. Reconnect the battery cables (positive cable first).

18. Reprogram the radio presets and reset the clock.

19. Make sure the side air bag wire harness is not in the way of the seat movement:

- a. Look under the seat.
- b. Operate the seat forward, backward, up and down.
- c. Make sure the harness is not pulled tight, pinched, caught, or otherwise in the way of the seat movements.

20. Make sure this procedure is performed on both front seats.

21. Connect CONSULT-III plus to the vehicle and check air bag codes.

- Erase any stored side module "open circuit" codes (SIDE MODULE RH or LH [OPEN]: B1129 or B1134) - Current or Past.

22. Disconnect CONSULT from the vehicle.

23. Turn the ignition OFF and then ON. Make sure the air bag warning lamp (on the instrument panel) turns ON and then goes OFF after about 7 seconds.

#### PARTS INFORMATION

MODEL	DESCRIPTION	PART #	QTY
Q45	Band -Hose (Tie-wrap for side air bag connector)	24216 - W1000	2
	VersaChem 5 MINUTE® EPOXY GEL (or equivalent)	46509 (Local Source)	Shop Supply

#### NOTE:

- Use VersaChem 5 MINUTE® EPOXY GEL (item number 46509) or equivalent.
- VersaChem 5 MINUTE EPOXY® GEL is available from NAPA stores (NAPA item number is 765-2417)
- Refer to the VersaChem web site for MSDS information ([www.versachem.com](http://www.versachem.com)).

#### CLAIMS INFORMATION

Submit a Campaign (CM) line claim using the following claims coding:

CAMPAIGN ID #	DESCRIPTION	OP CODE	FRT
R1204	Service Side Air Bag Connector for Both Front Seats	R12040	1.0 hrs.

