

POSTED ON ISIS

JUN 1 1 2012

MAILED

JUN 18 2012

Compliance Dept

Compliance Dept.

# **SERVICE PROCEDURE**

**G-12511  
JUNE 2012**

**SUBJECT: SAFETY RECALL**  
**Bendix® ATR-6™ brake valve on certain DuraStar®, WorkStar®, 9800, LoneStar®, and ProStar® truck models built 12/02/2010 thru 01/26/2012 with traction control or stability control and operate in Line Haul service that were not included in previous releases.**

## **DEFECT DESCRIPTION**

Bendix Commercial Vehicle Systems LLC has determined that a potential defect related to motor vehicle safety exists in Bendix® ATR-6™ valves manufactured between December 02, 2010 and January 18, 2012. In extremely cold conditions (at or below 0° F or -18° C), the Bendix® ATR-6™ valve can experience internal leakage, resulting in air pressure being delivered to the affected service brake circuit and may cause intermittent or, in isolated cases, continuous brake application.

## **MODELS INVOLVED**

This safety recall involves certain DuraStar®, WorkStar®, 9800, LoneStar®, and ProStar® truck models built 12/02/2010 thru 01/26/2012 with feature codes 04AZJ, 04AZV, 04BAG (Traction Control) or feature codes 04AZR, 04AZS, 04AZW, 04AZY (Stability Control) and operate in Line Haul service that were not included in previous releases.

**NOTE:** See page 5 for specific parts return information.

## **PARTS INFORMATION**

<b>Part Number</b>	<b>Part Description</b>	<b>Quantity</b>
8900225R91	ATR-6 Valve Safety Recall Reman Kit	With ATC only – 1 kit. With ATC and Roll Stability – 2 kits
8900226R91	ATR-6 Valve Safety Recall New Kit	With ATC only – 1 kit. With ATC and Roll Stability – 2 kits

Navistar Part # 8900225R91 contains the following parts:

Part Number	Part Description	Quantity
BXK070677	Bendix® ATR-6™ Brake Valve Kit (Reman Kit)	1

Navistar Part # 8900226R91 contains the following parts:

Part Number	Part Description	Quantity
BXK071015	Bendix® ATR-6™ Brake Valve Kit (New Kit)	1

**NOTE:** Dealers must order the 8900226R91 kit for vehicles in dealer inventory or that have not been DTU'd.

### **SERVICE PROCEDURE**

**WARNING!** To prevent personal injury or death, shift transmission to park or neutral, set parking brake, and block wheels before doing diagnostic or service procedures.

**WARNING!** To prevent personal injury or death, do not let engine fluids stay on your skin. Clean skin and nails using hand cleaner and wash using soap and water. Wash or discard clothing and rags contaminated with engine fluids.

## All Models

1. Park vehicle on a level surface and block wheels.
2. If vehicle you are working on has roll stability and cab air-ride suspension, disconnect cab-leveling valve and raise cab.
3. Remove electrical connections at batteries. Always remove negative battery cable first.
4. Drain air pressure from all vehicle air tanks.
5. Starting with the rear valve, identify, mark, or label all air lines and wiring cables and their respective connections on relay valve to facilitate ease of installation.
6. Disconnect all air lines and disconnect electrical connector.
7. Note and mark mounting position of relay valve on vehicle. Remove and save relay valve mounting hardware and remove relay valve from vehicle.
8. Follow procedure one, steps 5 through 10, on attached Bendix instructions to replace top cover, ball, seal, and gaskets with those supplied in the kit.
9. Mount relay valve on vehicle, orient it in the position marked on the valve, and tighten mounting bolts to specification.
10. Connect all air lines and reconnect electrical connector to relay valve using identification made prior to valve removal.
11. If vehicle you are working on does not have roll stability, proceed to step 25; otherwise, continue with the next step.
12. If equipped with a driver's side under door panel, open the hood, remove lamp and block heater receptacle from driver's side under door panel (if equipped), and remove panel.
13. Remove upper tank step (if working on a day cab).
14. Remove aerodynamic side skirts (if equipped).
15. Remove under-door panel mounting bracket.

16. Disconnect air line from relay cover control port and disconnect electrical connector.
17. Follow procedure one, steps 5 through 10, on attached Bendix instructions to replace top cover, ball, seal, and gaskets with those supplied in the kit.
18. Reconnect air line to relay cover control port and reconnect electrical connector to relay valve.
19. Reinstall under-door panel mounting bracket.
20. Reinstall aerodynamic side skirts (if previously removed).
21. Reinstall upper-tank step (if previously removed).
22. Reinstall driver's-side under door panel.
23. Reinstall lamp and block heater receptacle on driver's-side under-door panel (if previously removed).
24. Lower cab and reconnect leveling valve.
25. Reconnect electrical connections to batteries. Always reconnect ground cable last.
26. Start engine and build air pressure until full air pressure has been attained.
27. Perform chuff test, procedure three, in attached Bendix instructions.
28. Perform operational and leakage tests, procedure four, in attached Bendix instructions.
29. Close hood and remove wheel blocks.

## **END OF SERVICE PROCEDURE**

**LABOR INFORMATION**

Operation Number	Description	Time
A40-12511-1	Traction control only (one valve) – all models	0.7
A40-12511-2	Traction control and roll stability (two valves) – all models with cab air ride excluding LoneStar® and ProStar® with aerodynamic skirts	1.0
A40-12511-3	Traction control and roll stability (two valves) – all models without cab air ride	1.1
A40-12511-4	Traction control and roll stability (two valves) LoneStar® and ProStar® with aerodynamic skirts	1.6

**PARTS RETURN INFORMATION**

US dealers – All replaced covers MUST be returned via UPS collect billing account #RW1663 to:

Bendix CVS  
 Attn: Recall Returns Department  
 1850 Riverfork Drive  
 Huntington, IN 46750

Canadian dealers – All replaced covers MUST be returned via Purolator Courier Ground collect billing account #016474777 (shipments under 200 pounds) to:

Bendix CVS Canada  
 Attn: Recall Returns Department  
 8851 4e Croissant  
 Anjou, Quebec H1J 1A9

**CAMPAIGN IDENTIFICATION LABEL**

Each vehicle corrected in accordance with this campaign must be marked with a CTS-1075 Campaign Identification Label.

Complete the label and attach on a clean surface next to the vehicle identification number (VIN) plate.



## ADMINISTRATIVE/DEALER RESPONSIBILITIES

### WARRANTY CLAIMS

Warranty claim expense is to be charged to Warranty. Claims are to be submitted in the normal manner, making reference to Safety Recall 12511.

It is important that the coding be completed properly to assist in processing the warranty claim. Complete instructions will be found in the Warranty Policy Manual, Section 7.1.8.

As with all claim submission, items acquired locally must be submitted in the "Other Charges" tab. The cost of any bulk items (bag of cable tie straps, roll of wire, barrel of oil, tube of silicone, etc.) should be prorated for the cost of the individual pieces/amount used during each repair.

GROUP	NOUN	C	WARR.	TP	PAD

GROUP — Enter number G — ←

NOUN — Leave blank ←

C (CAUSE) — Enter either 1, 2, 3. (See below)

1. Inspected (No repair required).
2. Inspected and repaired.
3. Defective part from parts stock.

WARRANTY — (Warranty Code) Enter 40. ←

TYPE PART — Enter P for type part causing failure. ←

PAD — Enter 100 ←

### UNITED STATES AND POSSESSIONS

The National Traffic and Motor Vehicle Safety Act, as amended, provides that each vehicle that is subject to a vehicle recall campaign must be adequately repaired within a reasonable time after the owner has tendered it for repair. A failure to adequately repair within 60 days after a tender of a vehicle is prima facie evidence of failure to repair within a reasonable time. If the condition is not adequately repaired within 60 days, the owner may be entitled to replacement with an identical or reasonable equivalent vehicle at no charge, or to a refund of the purchase price less a reasonable allowance for depreciation.

Dealers must correct all vehicles subject to this campaign at no charge to the owner, regardless of mileage, age of vehicle, or ownership, from this time forward.

Dealers should proceed immediately to make necessary correction to units in inventory. All inventory vehicles subject to this recall campaign must be corrected prior to sale, transfer, or delivery. If vehicles have been sold or transferred and you are in receipt of Customer Notification Letters and Authorization for Recall Service cards for those vehicles, the transfer location or customer must be notified immediately from your dealer location.

Dealers must make every effort to promptly schedule an appointment with each owner to repair his or her vehicle as soon as possible. However, consistent with the customer notification, dealers are expected to complete the repairs on the mutually agreed upon service date.

Dealers involved in the recall process will be furnished a listing of owner names and addresses to enable them to follow up with owners and have the vehicles corrected. Use of this listing must be limited to this campaign because the list may contain information obtained from state motor vehicle registration records and the use of such motor vehicle registration data for purposes other than this campaign is a violation of law in several states.

## **CANADA**

Dealers must correct all vehicles subject to this campaign at no charge to the owner, regardless of mileage, age of vehicle, or ownership, from this time forward.

Dealers should proceed immediately to make necessary correction to units in inventory. All inventory vehicles subject to this recall campaign must be corrected prior to sale, transfer, or delivery. If vehicles have been sold or transferred and you are in receipt of Customer Notification Letters and Authorization for Recall Service cards for those vehicles, the transfer location or customer must be notified immediately from your dealer location.

Dealers must make every effort to promptly schedule an appointment with each owner to repair his or her vehicle as soon as possible. However, consistent with the customer notification, dealers are expected to complete the repairs on the mutually agreed upon service date.

Dealers involved in the recall process will be furnished a listing of owner names and addresses to enable them to follow up with owners and have the vehicles corrected. Use of this listing must be limited to this campaign because the list may contain information obtained from state motor vehicle registration records and the use of such motor vehicle registration data for purposes other than this campaign is a violation of law in several states.

## **EXPORT**

Export Distributors should proceed immediately to make necessary correction to units in inventory. All inventory vehicles subject to this recall campaign must be corrected prior to sale, transfer, or delivery. If vehicles have been sold or transferred and you are in receipt of Customer Notification Letters and Authorization for Recall Service cards for those vehicles, the transfer location or customer must be notified immediately from your distributor location.

Export Distributors are to submit warranty claims in the usual manner making reference to this recall number.

Export Distributors are expected to provide full cooperation and follow-up with respect to this important subject matter. If you have any questions or need further assistance, please contact the Regional Service Manager at your regional office.

**NAVISTAR, INC**



## How to Install a Replacement Cover Assembly for a Bendix® ATR-6™ Traction Relay Valve (Kits K070677 and K071015)

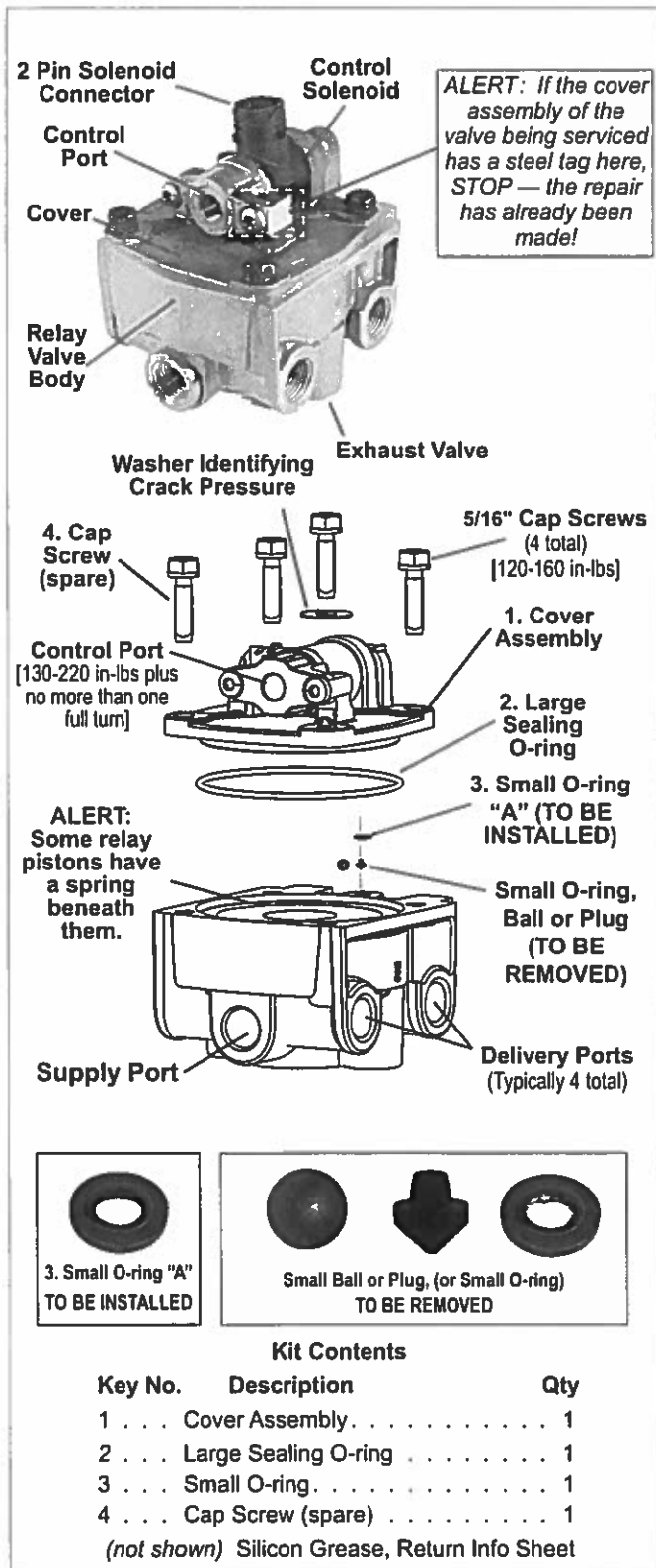

**FOLLOW ALL STANDARD INDUSTRY SAFETY PRECAUTIONS, INCLUDING THOSE LISTED ON PAGE FOUR OF THIS DOCUMENT.** Park the vehicle on level ground, chock the wheels, **FULLY DRAIN ALL** the reservoirs, and turn off the ignition. Locate the Bendix® ATR-6™ Traction Relay Valve(s) on the vehicle.

**CAUTION:** You must **FULLY** complete **ALL FOUR PROCEDURES, IN ORDER.**

### OVERVIEW:

**PROCEDURE ONE:**

Changeout the cover assembly and remove the temporary blocking device (if present), and install the O-ring(s). *(If necessary, remove the valve from the vehicle to service.)*

Repeat this procedure for ALL ATR-6 valves present on the vehicle before continuing.

**PROCEDURE TWO:**

Return the removed cover.

Please retain your shipping carton and packing materials for this Procedure.

**PROCEDURE THREE:**

**NOTE:** If you are servicing two Bendix® ATR-6™ Traction Relay Valve(s) on the vehicle, wait until both cover assemblies have been replaced before carrying out Procedure Three.

Use the Chuff Test and the ATC/ESP lamp to confirm that the replacement procedure is completed.

**PROCEDURE FOUR:**

Complete the *Operational and Leakage Tests.*

**FIGURE 1 - BENDIX® ATR-6™ TRACTION RELAY VALVE**

**PROCEDURE ONE: Changeout the cover assembly and replace the temporary blocking device (if used) with a small O-ring. (If necessary, remove the valve from the vehicle to service.)**

1. Verify that the Bendix® ATR-6™ valve does not have a steel tag (See Figure 1) that indicates it has already been serviced.
2. **Clean the valve and take care to avoid any contamination inside the valve during these procedures.**
3. Disconnect the electrical connector from the traction solenoid.
4. With ALL reservoirs drained, remove the air hose from the control port of the relay valve cover.
5. Be sure to mark the orientation of the cover. Using hand wrenches, remove and retain the four cap screws (and I.D. washer) and bracket(s). (ALERT: Some relay pistons have a spring beneath them).  
NOTE: If cap screw(s) break off, or are stripped, install a replacement ATR-6 valve (or relay valve lower body). A spare cap screw is included in the kit.
6. • **Remove and discard the ball or plug ("A" in Figure 1) from between the cover and the valve, OR,**  
• **For ATR-6 valves that have not been serviced by a temporary disable kit, there will not be a ball or plug; remove and discard the original small O-ring.**
7. Remove and discard the large sealing O-ring.
8. Grease and install the new large sealing O-ring(2) and the small O-ring (3) supplied, into the NEW valve cover.

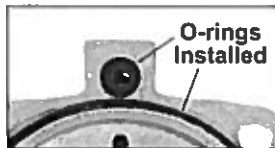

9. Verify that no contamination has entered the valve. You MUST remove any debris inside. Use a clean shop cloth/shop air and use the supplied grease to replace any removed. With the replacement cover assembly (and mounting bracket) in the same orientation as the original, place the cover assembly into position over the valve body.

USE HAND-WRENCHES (ideally torque-wrenches) to re-install the four cap screws and I.D. washer in the cover and torque (in a cross-pattern) to 120-160 in-lbs. NOTE: All torques specified are assembly torques and can be expected to fall off slightly after assembly. Do not re-torque after the initial assembly torque falls off; **Do not over-tighten — overtightening could crack the cover or strip the threads.**

10. Reconnect the control air hose to the cover. Torque to 130-220 in-lbs, plus no more than one full turn. [If it was necessary to remove the valve from the vehicle, reinstall the Supply and Delivery hoses, using a torque of 180-340 in-lbs, plus no more than one full turn.] Follow OEMs recommendations for re-installing the valve/any brackets to the vehicle.

11. Reconnect the wire harness to the traction solenoid.
12. Repeat steps 1-11 where a second Bendix ATR-6 is present.



**PROCEDURE TWO:  
Return the removed cover assembly/  
assemblies.**

The arrangements for returning the removed cover(s) vary:

If you are filing this claim through the vehicle manufacturer	Follow the OEM's return part process for returning the part and making the claim.
Returning Parts (Non-OE)	1. Please complete the information sheet enclosed. (One form per shipping box.)
	2. Put the removed cover(s) in their respective parts box(es).
	3. Put the form(s) and parts box(es) into the original outer shipping box. Seal the box(es).
	4. Return the cover and form to file the claim.



### PROCEDURE THREE:

**NOTE:** If you are servicing two Bendix® ATR-6™ Traction Relay Valves on the vehicle, wait until both cover assemblies have been replaced before carrying out Procedure Three.

**Use the Chuff Test (or Bendix® ACom® diagnostics software - see step 4) to confirm that the replacement cover(s) are functioning.**

1. Power-up and FULLY charge the vehicle's air brake system (listen for the air dryer exhaust). Turn the vehicle off.

The **Bendix Chuff Test** occurs after ignition power is applied and during it, in sequence, the ABS modulator valves are energized and the ATR-6 valve(s) emit a short burst of air (the rear ATR-6 valve has a much quieter exhaust during the Chuff Test than the front valve).

**NOTE:** This Procedure requires the brakes NOT be applied.

2. **Check the rear ATR-6 valve:** Have the ignition switch activated (brakes not applied) while a technician closely monitors the rear ATR-6 valve. Listen closely, or use your hand to feel for a short release of air. With the new cover installed, the ATR-6 valve WILL perform the momentary exhaust as normal.

3. **Check the front ATR-6 valve (if present):** Repeat the chuff test [again, brakes not applied].  
Listen for the front ATR-6 valve during the Chuff Test. The front ATR-6 valve with an enabled solenoid emits a short audible burst of air. With the new cover installed, the ATR-6 valve WILL perform the momentary exhaust as normal.

**CAUTION:** If you DO NOT observe an exhaust from the ATR-6 valve(s) during the Chuff Test, go back to Procedure One and check that the bail or plug was removed from the valve that is not exhausting air.

4. The ALTERNATE TEST using PC-based Bendix ACom diagnostics' Component Test Feature permits the ATR-6 valves to be selected and cycled. Follow the directions on the Component Test screen.

5. Since the traction functionality has been restored, at vehicle start-up, the ATC/ESP lamp will briefly illuminate (as a bulb-check) and then go out.

If the lamp remains ON, see the Bendix Service Data sheet for the ABS system or call the Tech Team.

6. Verify that the ABS lamp illuminates briefly at start-up. If the lamp remains ON, see the Bendix Service Data sheet for the ABS system or call the Tech Team.



### PROCEDURE FOUR:

**Complete the Operational and Leakage Tests.**

1. Always check the vehicle brake system for proper operation after performing brake work and before returning the vehicle to service. Chock the wheels, and fully charge the air brake system.

2. **Operational Test:** Apply and release the brakes several times and check for prompt application and release at each wheel.

If an incomplete or sluggish release of the brakes is noted at some, but not all wheels, test the Antilock Modulator Valve(s) operating those wheels for proper operation, and inspect for a kinked or obstructed air hose leading to, or from, the Modulator(s).

If an incomplete or sluggish release is noted at all wheels, inspect for a kinked or obstructed air hose leading to, or from, the ATR-6™ valve(s).

#### Three Part Leakage Test:

- 3a. With the air system pressure charged to governor cut-out, apply a soap solution to the exhaust port(s). The leakage noted should not exceed a one-inch bubble in 3 seconds.

- 3b. Make and hold a full brake application and apply a soap solution to the exhaust port and around the cover where it joins the body. The leakage noted should not exceed a one-inch bubble in 3 seconds at the exhaust port(s).

- 3c. Check for inlet valve and O-ring leakage. Make this check with the service brakes released. Coat the exhaust port(s) and the area around the relay valve exhaust retaining ring(s) with a soap solution; leakage of a one-inch bubble in 3 seconds is permitted.



**ALL PROCEDURES, ONE THROUGH FOUR MUST BE COMPLETED FOR THE KIT(S) USED, TO BE EFFECTIVE AND THE VEHICLE RETURNED TO SERVICE.**

Before returning the vehicle to service, perform the *Operational and Leakage Tests*.

**Double-check the dash ATC lamp is no longer illuminated before operating the vehicle.**

**REMOVE ANY TEMPORARY SIGNAGE** alerting the driver that the ATR-6 valve's solenoid was temporarily disabled (if present).

## GENERAL SAFETY GUIDELINES

### **WARNING! PLEASE READ AND FOLLOW THESE INSTRUCTIONS TO AVOID PERSONAL INJURY OR DEATH:**

When working on or around a vehicle, the following general precautions should be observed at all times.

1. Park the vehicle on a level surface, apply the parking brakes, and always block the wheels. Always wear safety glasses.
2. Stop the engine and remove Ignition key when working under or around the vehicle. When working in the engine compartment, the engine should be shut off and the ignition key should be removed. Where circumstances require that the engine be in operation, EXTREME CAUTION should be used to prevent personal injury resulting from contact with moving, rotating, leaking, heated or electrically charged components.
3. Do not attempt to install, remove, disassemble or assemble a component until you have read and thoroughly understand the recommended procedures. Use only the proper tools and observe all precautions pertaining to use of those tools.
4. If the work is being performed on the vehicle's air brake system, or any auxiliary pressurized air systems, make certain to drain the air pressure from all reservoirs before beginning ANY work on the vehicle. If the vehicle is equipped with an AD-IS® air dryer system or a dryer reservoir module, be sure to drain the purge reservoir.
5. Following the vehicle manufacturer's recommended procedures, deactivate the electrical system in a manner that safely removes all electrical power from the vehicle.
6. Never exceed manufacturer's recommended pressures.
7. Never connect or disconnect a hose or line containing pressure; it may whip. Never remove a component or plug unless you are certain all system pressure has been depleted.
8. Use only genuine Bendix® replacement parts, components and kits. Replacement hardware, tubing, hose, fittings, etc. must be of equivalent size, type and strength as original equipment and be designed specifically for such applications and systems.
9. Components with stripped threads or damaged parts should be replaced rather than repaired. Do not attempt repairs requiring machining or welding unless specifically stated and approved by the vehicle and component manufacturer.
10. Prior to returning the vehicle to service, make certain all components and systems are restored to their proper operating condition.
11. For vehicles with Automatic Traction Control (ATC), the ATC function must be disabled (ATC indicator lamp should be ON) prior to performing any vehicle maintenance where one or more wheels on a drive axle are lifted off the ground and moving.

**CAUTION:** It is very important to be sure that the air pressure has been completely drained from all vehicle reservoirs. Any remaining air pressure would be present underneath the Relay Piston, presenting a hazard to the technician during valve disassembly.

### **Bendix Technical Assistance Team**

For direct telephone technical support, call the Bendix Tech Team at:

1-800-AIR-BRAKE (1-800-247-2725), option 2, then option 1. Follow the instructions in the recorded message.

*(For a limited period, phone lines are being staffed for extended hours.)*

Our normal hours are Monday through Thursday, 8:00 A.M. to 6:00 P.M., Friday, 8:00 A.M. to 5:00 P.M., EST.

Or, you may e-mail: [techteam@bendix.com](mailto:techteam@bendix.com)

Please have the following information ready when you call: Bendix product model number, part number and configuration, vehicle make and model, vehicle configuration (number of axles, tire size, etc.).

**Reference:** The full Service Data sheet for the Bendix® ATR-6™ Traction Relay Valve is SD-13-4861 (BW2598) and is available for download on [www.bendix.com](http://www.bendix.com), or you can order copies from the Literature Center at the website.

