

CERTAIN 2012 MODEL YEAR EXPEDITION AND NAVIGATOR VEHICLES — PASSENGER SIDE SECOND ROW SEAT BACKREST FRAME INSPECTION AND REPAIR

OVERVIEW

This program involves the inspection of the passenger side second row seat backrest frame build code.

- If the build code begins with "B0", the backrest frame does not need to be replaced.
- If the build code begins with "B1", the backrest frame must be replaced.

INSPECTION

Armrest Removal (If equipped)

1. Rotate the armrest to the vertical position.
2. Locate the zipper in the armrest cover zipper pocket. See Figure 1.

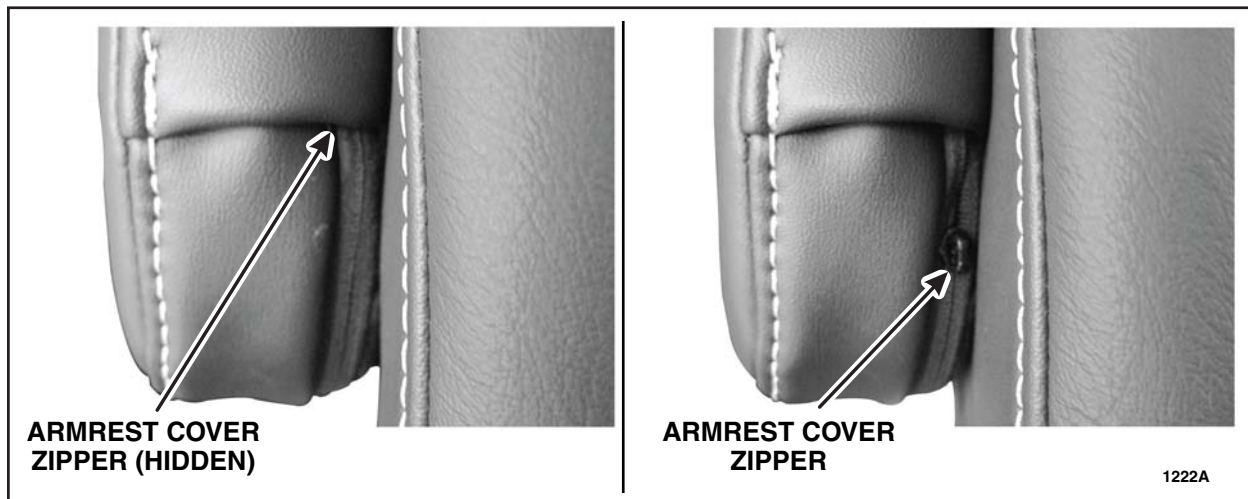

FIGURE 1

3. Unzip the armrest cover. See Figure 1.



4. Partially roll back the armrest cover to access the armrest pivot bolt. See Figure 2.

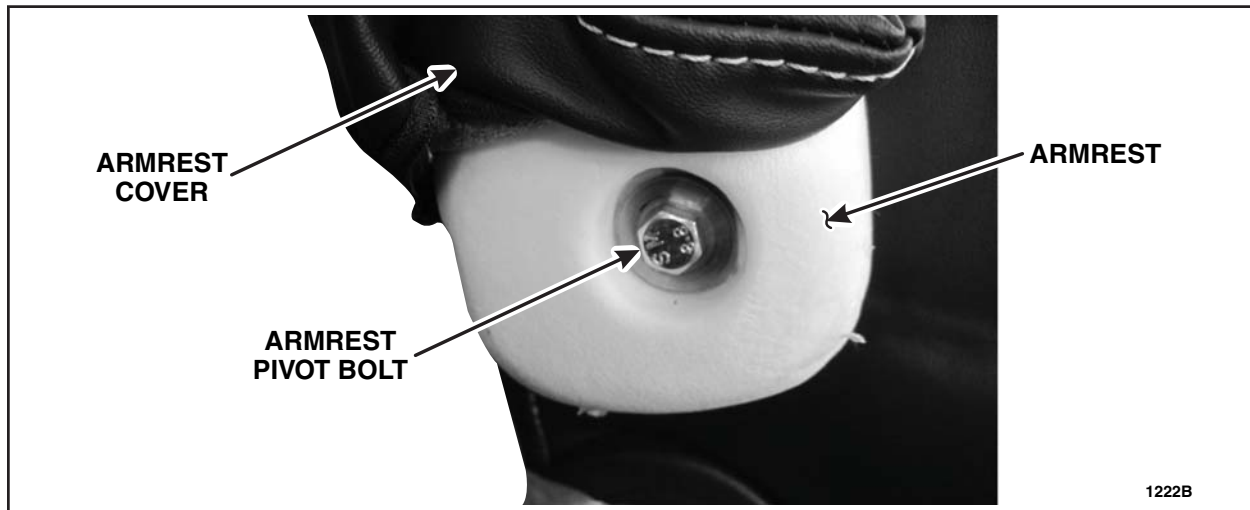

FIGURE 2

5. Remove the armrest pivot bolt and the armrest. See Figure 2.

Seat Backrest Cover Removal

NOTICE: Use care when releasing the spring clips. They can fall inside the backrest frame.

6. Remove the head restraint. See Figure 3.

- Pull the backrest cover material away from both of the head restraint guides to access the spring clips.
- Release the 2 spring clips.
- Raise and remove the head restraint.

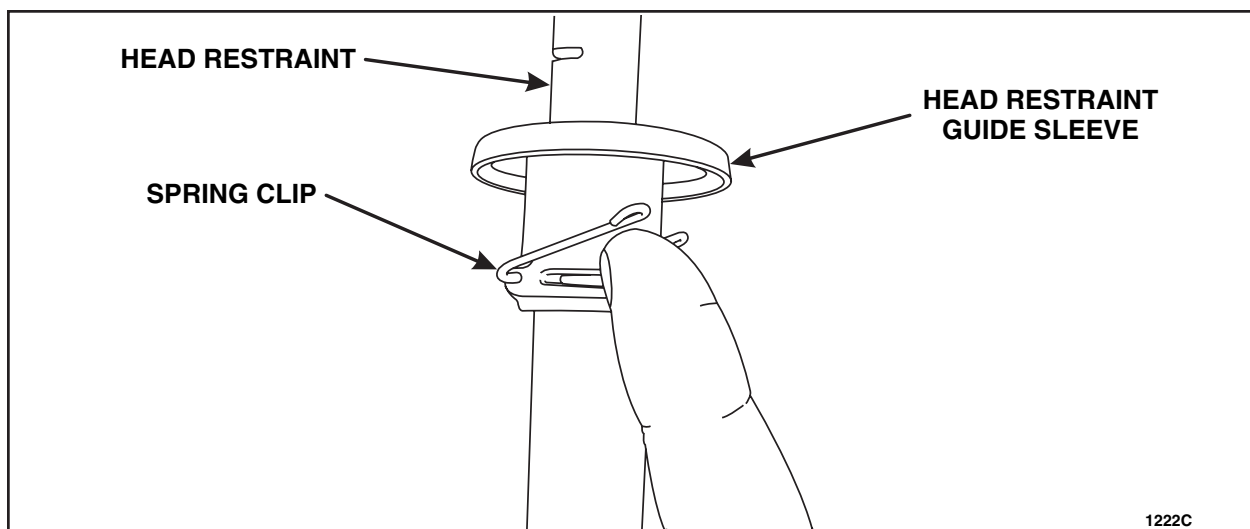

FIGURE 3



7. Position the seat backrest to the fold flat position.
8. Remove the cargo mode handle.
 - a. Raise the handle to access the cable.
 - b. Detach the cable jacket from the cargo mode handle.
 - c. Release the retainers and position aside the cargo mode handle.
9. Release the lower backrest cover J-clip.
10. Position aside the backrest cover rear flap and remove the four (4) pin-type retainers. See Figure 4.

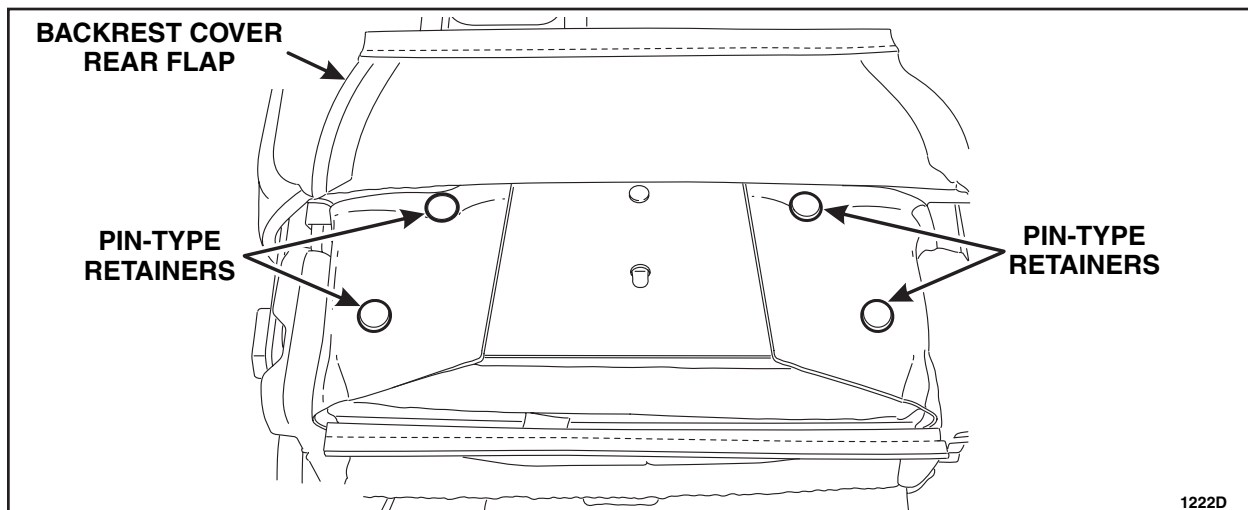

FIGURE 4

11. If equipped, disconnect the backrest heater mat electrical connector. See Figure 5.
 - a. Release the cushion cover J-clip.
 - b. Disconnect the electrical connector.
 - c. Detach the electrical connector and heater mat wiring pin-type retainers.

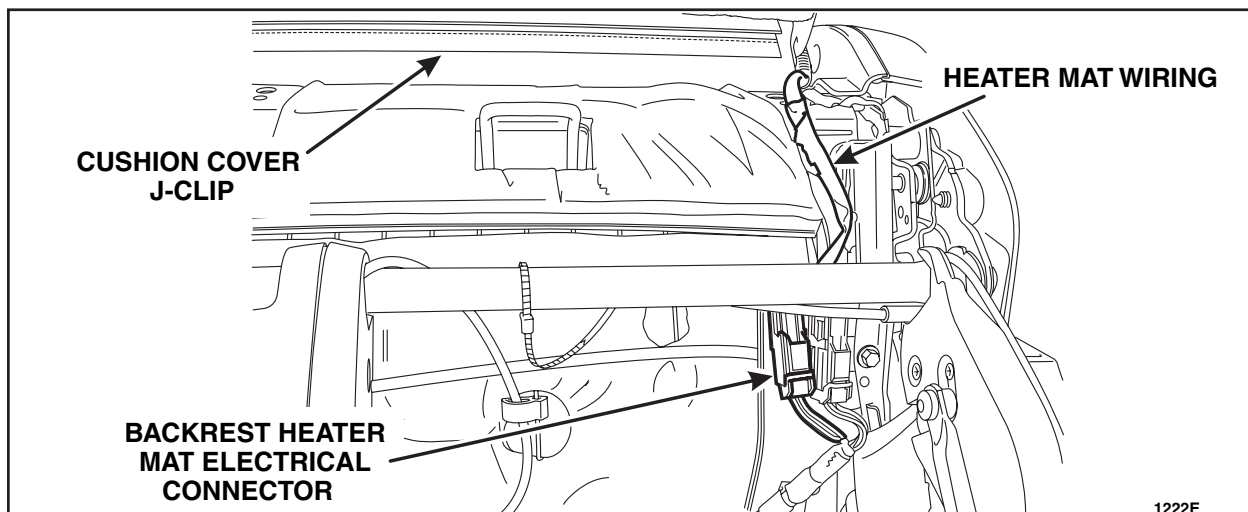

FIGURE 5



12. Raise the backrest and route the lower backrest cover J-clip between the backrest and the cushion.

NOTICE: Use care when separating the seat backrest trim cover from the hook-and-loop strip, or the hook-and-loop strip may be torn from the seat backrest foam pad.

13. Partially roll up/raise the backrest cover toward the head restraint guides.

- a. Separate the hook-and-loop strips.
- b. If equipped, ensure the heater mat wiring remains in place during removal of the cover.

14. Remove the row of hog rings.

15. Continue raising/rolling up the backrest cover to the head restraint guides.

NOTICE: Use care when separating the head restraint guides and spring clips to avoid tearing or damaging the backrest cover.

16. Pinch the head restraint guide ends to release and remove the 2 head restraint guides.

17. Remove the backrest cover.

18. Remove the foam backrest pad from the seat backrest frame. If equipped, use caution not to damage the heater mat wiring when removing the foam pad.

19. Inspect the seat backrest frame build code. See Figure 6.

- If code begins with "B1", proceed to the "Seat Backrest Frame Replacement Procedure" on Page 5.
- If code begins with "B0", the seat backrest does not require replacement. Install the foam backrest pad and proceed to "Seat Backrest Cover Installation" on page 7.

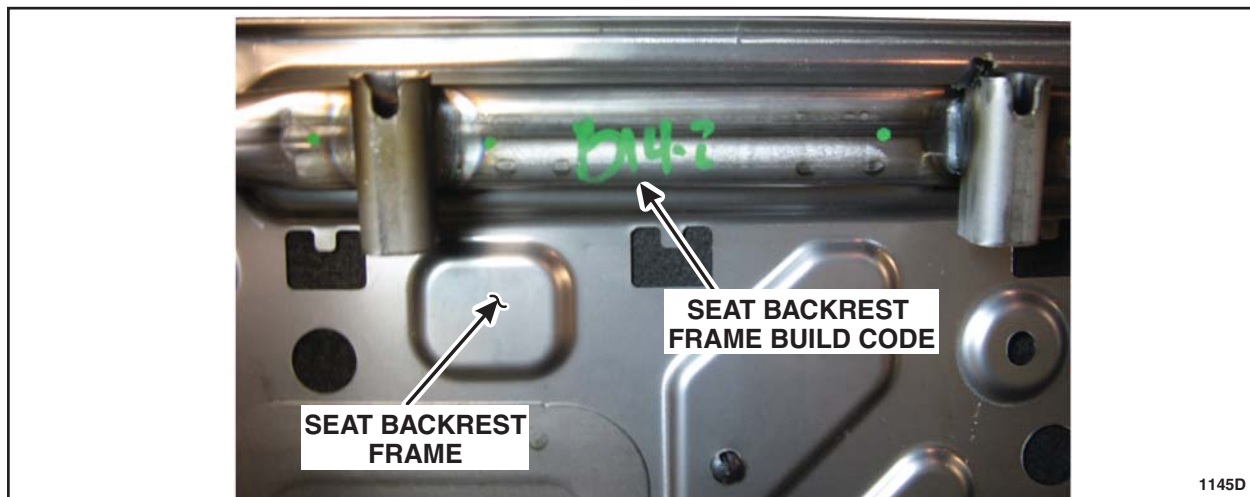

FIGURE 6



SEAT BACKREST FRAME REPLACEMENT PROCEDURE

Seat Backrest Frame Removal

1. Position the seat backrest to the fold flat position.
2. Remove the three (3) push-pins and the seat frame backing. See Figure 1.

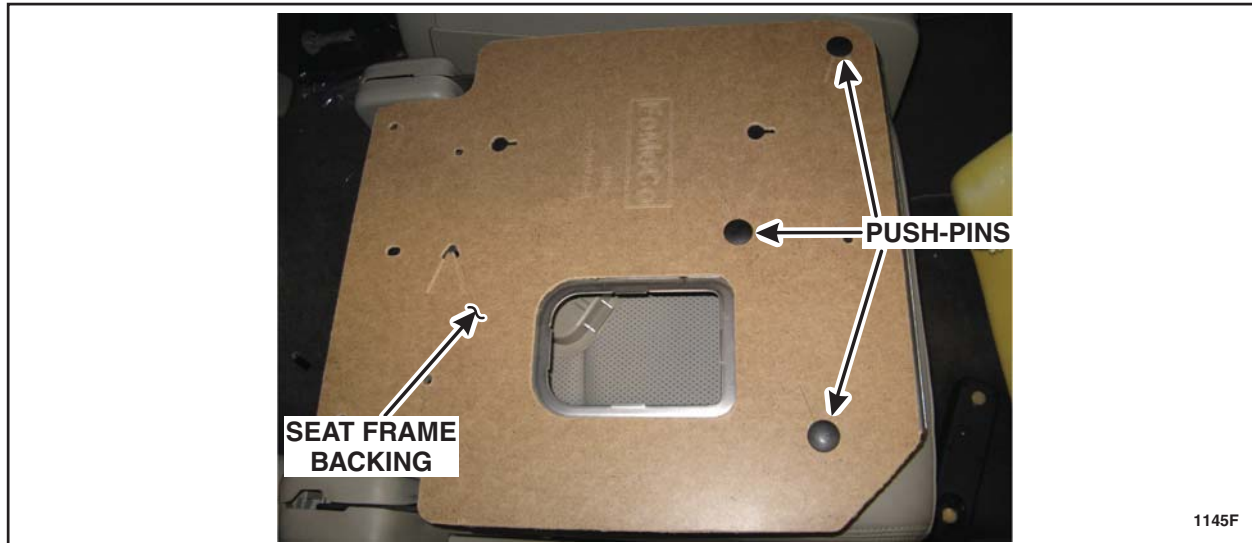

FIGURE 1

3. Move the seat backrest to the upright position.
4. Disconnect the cable push-pin retainer from the seat backrest frame. See Figure 2.

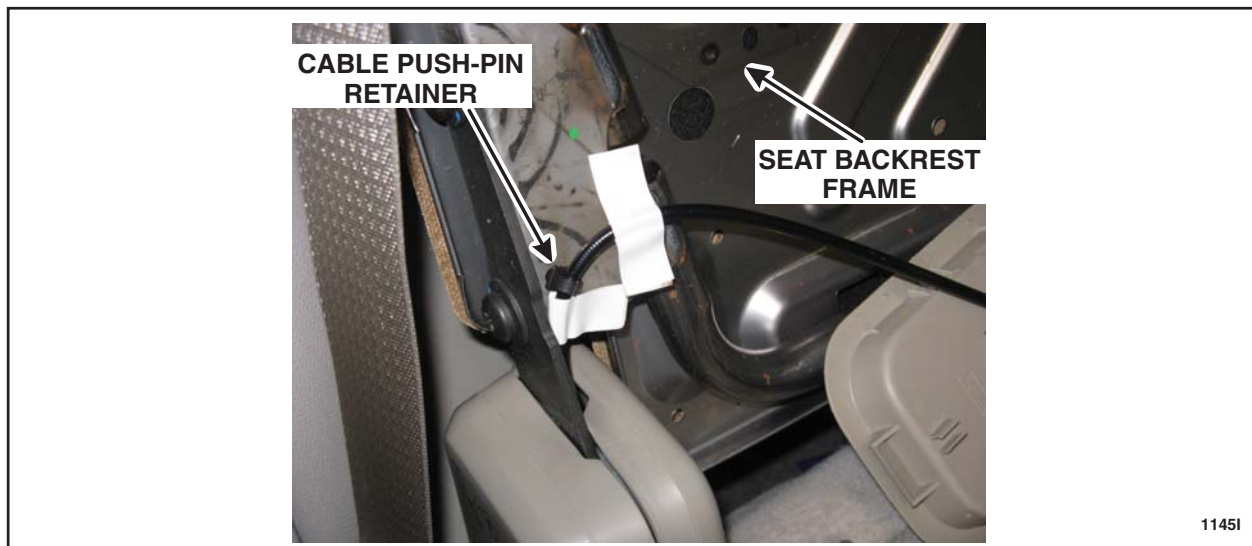

FIGURE 2



5. Position the cargo mode handle through the seat backrest.

NOTICE: The following steps identified as "CRITICAL" must be performed exactly as described in order for the seat to function properly.

6. **CRITICAL:** Verify the seat backrest is in the upright position and is latched / locked. The backrest MUST remain in the upright latched / locked position until after the *new* backrest frame is installed and fasteners are tightened.

7. **CRITICAL:** Mark the backrest frame-to-recliner position as shown in Figure 3. This mark will allow the *new* frame to be installed in the exact alignment as the original frame. If the *new* frame is not aligned properly, the seat will not function in all seat positions.

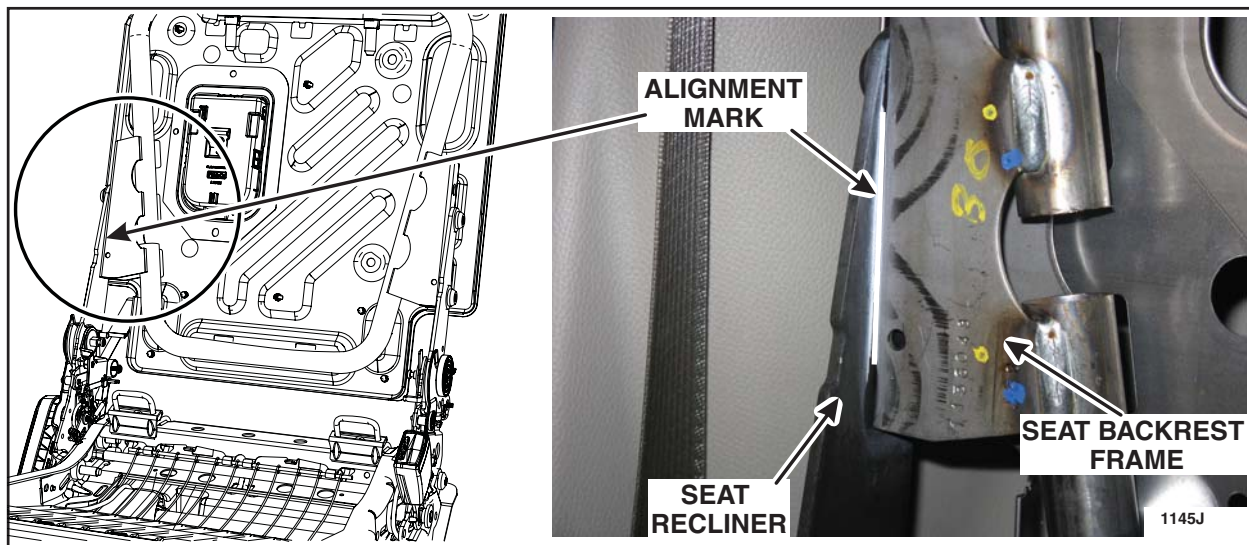

FIGURE 3

8. Remove the four (4) seat backrest frame-to-recliner fasteners and the seat backrest frame.

Seat Backrest Frame Installation

9. **CRITICAL:** Verify the seat recliners are still latched / locked in the upright position. Install the *new* seat backrest and tighten the frame-to-recliner fasteners hand tight.

10. **CRITICAL:** Align the seat backrest frame-to-recliner marks made during disassembly. See Figure 3 above.

- Tighten backrest retainers to 55 Nm (41 lb-ft).

11. Position the cargo mode handle back through the seat backrest frame.



12. Connect the cable push-pin retainer to the seat backrest frame. See Figure 2, on Page 5.
13. Position the seat backrest to the fold flat position.
14. Install the seat backrest frame backing and the three (3) push-pin retainers. See Figure 1, on Page 5.
15. Move the seat backrest to the upright position.
16. Install the foam backrest pad. Ensure the heater mat wiring is properly routed between the backrest pad and the seat cushion.

Seat Backrest Cover Installation

17. Install the seat backrest cover down to the row of hog rings.
18. Install the 2 head restraint guides.
19. Install *new* hog rings.
20. Roll the backrest cover down to the base of the seat back, attaching the hook-and-loop strips.
21. Route the J-clip between the backrest and the cushion frame.
22. Position the seat backrest to the fold flat position.
23. If equipped, connect the backrest heater mat electrical connector. See Figure 5, on Page 3.
 - a. Attach the electrical connector and heater mat wiring pin-type retainers.
 - b. Connect the electrical connector.
 - c. Attach the cushion cover J-clip.
24. Position the backrest cover rear flap back and install the four (4) pin-type retainers. See Figure 4, on Page 3.
25. Attach the lower backrest cover J-clip.
26. Install the cargo mode handle and attach the cable jacket to the handle.
27. Move the seat backrest to the upright position.
28. Install the head restraint and engage the spring clips. See Figure 3, on Page 2.



Armrest Installation (If equipped)

NOTE: Make sure the armrest pivot guide pin on the seat backrest is lined up to the armrest pivot guide pin slot on the armrest.

29. With the armrest in the horizontal position, install the armrest onto the seat and start the armrest pivot bolt by hand. See Figure 2, on Page 2.

NOTE: Make sure the backrest cover is not pinched between the armrest spacer and the armrest bracket.

30. Tighten the armrest pivot bolt to 45 Nm (33 lb-ft).

31. Position the armrest cover back onto the armrest.

32. Zip the armrest cover and tuck the zipper up into the armrest cover zipper pocket. See Figure 1, on Page 1.

Seat Function Check

NOTE: There is no need to perform the function check if the seat backrest was not replaced. Return vehicle to customer after the seat backrest cover and armrest (if equipped) is installed.

33. **CRITICAL:** Function check the seat to verify proper operation.

- Check function of the tumble / easy entry position with the recliner handle and rear pull strap.
- Check function of the kneel position (load floor).
- Check to ensure the seat back will not open if the seat-to-floor latches are not locked to the striker plate.
- Check to ensure the seat back will not not open if the seat is in the load floor position.

NOTE: If seat does NOT function properly in ALL positions, verify that the "critical" steps on page 6 have been performed properly. Call the Special Service Support Center at 1-800-325-5621 if you are not able to get the seat to function properly in ALL positions.

32. Return the vehicle to the customer.

