



Applies To: **2012 Accord 2-Door** – Check the iN VIN status for eligibility
2012 Accord 4-Door – Check the iN VIN status for eligibility
2012 Crosstour – Check the iN VIN status for eligibility

May 4, 2012

Safety Recall: Driver's (Left) Side Curtain Airbag May Not Deploy

(Supersedes 12-008, dated February 10, 2012, to revise the information marked by the black bar)

REVISION SUMMARY

- For 2012 Civics – On February 10, 2012, American Honda announced this campaign during an ongoing investigation to replace the left side curtain airbag. Further investigation showed that the 2012 Civic was not affected by the defect, and therefore the safety recall was cancelled for the 2012 Civic. As a result, it is unnecessary to conduct any further repairs on 2012 Civic vehicles (whether in dealer inventory or customer-owned).
- An example of the Accord and the Crosstour customer letter was included.

BACKGROUND

An incorrect propellant mixture was used in the driver's side curtain airbag inflator. If the vehicle is involved in a crash, the driver's side curtain airbag may fail to deploy, leading to increased potential for injury or death.

CUSTOMER NOTIFICATION

Owners of affected vehicles will receive a notification of this campaign.

Do an **iN VIN status inquiry** to make sure the vehicle is shown as eligible.

In addition, check for a punch mark above the first character of the engine compartment VIN. A punch mark in that location means this campaign has already been completed.

Some vehicles affected by this campaign may be in your new or used vehicle inventory. These vehicles must be repaired before they are sold.

Should a dealership sell an unrepaired vehicle that subsequently causes an injury or damage because of the recalled item, the dealership will be solely responsible to the damaged party, and will be required to defend and indemnify American Honda for any resulting claims. To see if a vehicle in inventory is affected by this campaign, do a VIN status inquiry before selling it.

CORRECTIVE ACTION

Replace the driver's side curtain airbag.

PARTS INFORMATION

Left Side Curtain Airbag Module:

Accord 2-door (LX, LX-S) – P/N 78875-TE0-A80
 Accord 2-door (EX, EX-L) – P/N 78875-TE0-A90
 Accord 4-door (LX, SE) – P/N 78875-TA5-A60
 Accord 4-door (EX, EX-L) – P/N 78875-TA5-A70
 Crosstour – P/N 78875-TP6-A80

Front Clip (Accord and Crosstour):

P/N 91561-TA5-A01 (two required)

Rear Clip (Accord 4-door):

P/N 91561-TA5-A11 (two required)

WARRANTY CLAIM INFORMATION

OP#	Description	FRT
7521G1	Replace the driver's side curtain airbag - Accord 2-door	1.5
A	Replace the driver's side curtain airbag - add for Accord 4-door	0.4
7521G1	Replace the driver's side curtain airbag - Crosstour	2.3

Failed Part: P/N 78875-TE0-A90

Defect Code: 5HA00

Campaign Code: S1900

Skill Level: Repair Technician

REPAIR PROCEDURE – ACCORD 2-DOOR AND 4-DOOR

NOTE: This procedure is an outline form that you can also use as a checklist for the repair. If you need more details on the procedures listed below, bookmark them in the appropriate service manual, or view them online:

- Front Seat Removal/Installation
- Battery Terminal Disconnection and Reconnection
- Headliner Removal/Installation
- Trim Removal/Installation - Door Areas
- Trim Removal/Installation - Pillar Areas
- Sunvisor Removal/Installation
- Grab Handle Removal/Installation
- Glove Box Removal/Installation
- Ceiling Light Test/Replacement
- Rearview Mirror Replacement
- Side Curtain Airbag Replacement
- Component Replacement/Inspection After Deployment
- General Troubleshooting Information

NOTE: Don't deploy the airbag. WPI will contact your dealership to arrange for the return of the airbag.

1. Remove the front seat lower anchor from the driver's seat.
2. *2-door*: Slide the front seats all the way back, and recline the seat backs fully.
3. *4-door*: Remove the driver's seat, slide the passenger's seat all the way back, and recline the seat-back fully.
4. Do the battery terminal disconnection procedure, and wait 3 minutes before starting work.
5. Remove these items:
 - Passenger's side kick panel
 - Driver's and passenger's A-pillar trim
 - Driver's and passenger's upper B-pillar trim
 - Driver's and passenger's lower B-pillar trim (4-door)
 - Driver's and passenger's C-pillar trim (4-door)
 - Driver's and passenger's sunvisors and holders
 - Grab handles (two on 2-door, four on 4-door)
 - Glove box
 - Ceiling light
6. Remove the roof console.
7. If the vehicle is equipped with an automatic dimming mirror, remove the rearview mirror harness cover. Disconnect the connector from the rearview camera, and release the wire harness from the rearview mirror harness cover base.

8. If necessary, remove the roof console screw grommet by pinching out the hooks.
9. If necessary, release the hooks by prying out the map light clip, then remove the clip.
10. Disconnect the four harness clips that secure the roof wire harness to the driver's side A-pillar.
11. Remove the antenna lead at the dashboard side:
 - Detach the four harness clips from the passenger's side A-pillar.
 - From under the passenger's side of the dash, disconnect and detach the antenna lead connector, and detach the harness clip.
12. Remove the antenna lead at the AM/FM antenna amplifier side:
 - *2-door*: From the passenger's side C-pillar area, disconnect the antenna lead connector from the AM/FM antenna amplifier, and detach the harness clip. Pass the clip and connector through the gap between the projection on the side curtain airbag bracket and the glass antenna connector by pulling the antenna lead to the headliner side.
 - *4-door*: From the right C-pillar area, disconnect the antenna lead connector from the AM/FM antenna amplifier, and detach the harness clip.
13. If the vehicle is equipped with a moonroof, at the roof console opening, disconnect the moonroof subharness connector and detach the harness clip.
14. *2-door*: Lower the headliner.
 - Remove the door opening seals from the roof areas.
 - Release the headliner bracket hooks from the side curtain airbag brackets at the driver's and passenger's C-pillar areas.
 - With the help of an assistant, detach the rear headliner clips by pulling down on the rear area of the headliner.
 - If the vehicle is equipped with a moonroof, detach the front clips, the magnet, and the hook and loop fasteners by lowering the moonroof opening edge of the headliner.
15. *4-door*: Lower the headliner.
 - Remove the front and rear door opening seals from the roof areas.
 - With the help of an assistant, detach the rear headliner clips by pulling down on the rear area of the headliner.
 - If the vehicle is equipped with a moonroof, detach the front clips, the magnet, and the hook and loop fasteners by lowering the moonroof opening edge of the headliner.

16. Detach the roof wire harness from the headliner by carefully peeling back just enough tape to remove the harness.

NOTE:

- Don't remove all of the tape; it will be reused.
- Make sure the roof harness is out of the way so it doesn't get tangled with the headliner when you remove it.
- Leave the AM/FM antenna lead attached to the headliner.

WITHOUT MOONROOF - 2-DOOR

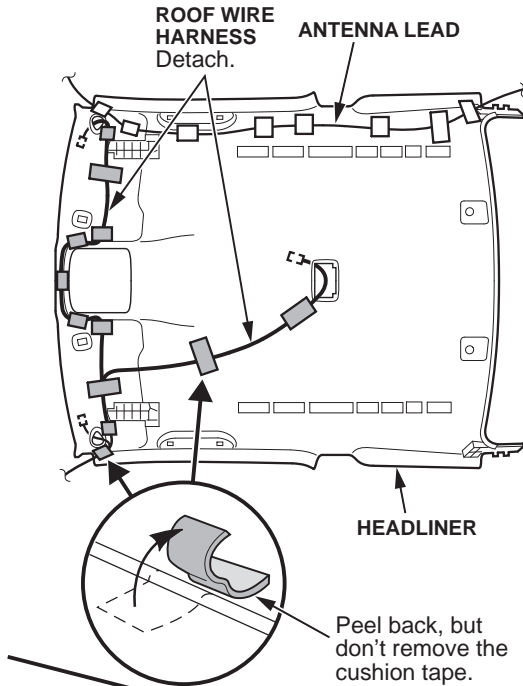

WITHOUT MOONROOF - 4-DOOR

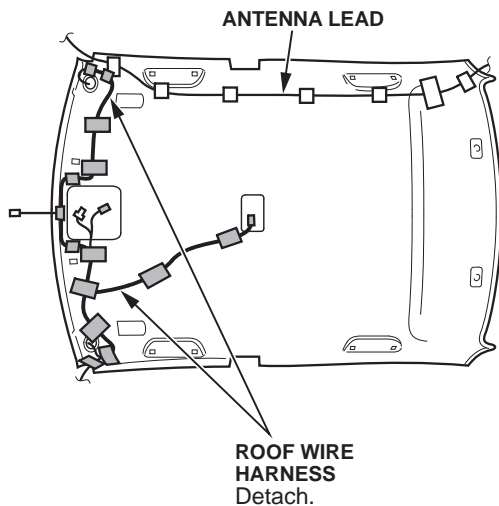

17. *2-door:* Remove the headliner.
 - Move the headliner rearward.
 - Lower the front of the headliner until it's below the steering wheel.

- Rotate the headliner so that the right front corner is pointing out the passenger's door and the left rear corner is pointing out the driver's door.
- Pull the headliner out through the passenger's door.

NOTE: Don't bend the headliner. Bending the headliner will crease and damage it.

18. *4-door:* Remove the headliner.
 - Move the headliner rearward.
 - Lower the front of the headliner until it's below the steering wheel.
 - Rotate the headliner so that the right front corner is pointing out the passenger's front door and the left rear corner is pointing out the left rear door.
 - Pull the headliner out through the left rear door.

NOTE: Don't bend the headliner. Bending the headliner will crease and damage it.

19. Disconnect the SRS floor wire harness 2P connector from the driver's side curtain airbag.

4-DOOR

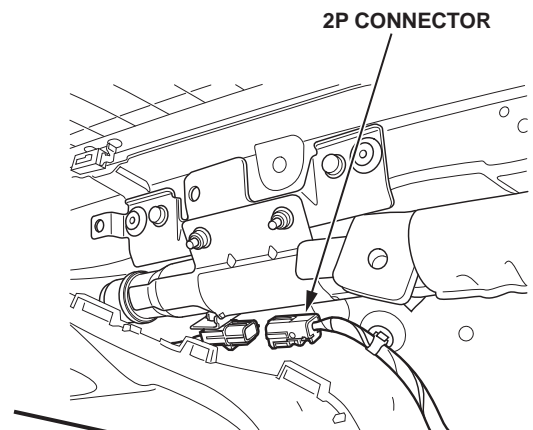

2-DOOR

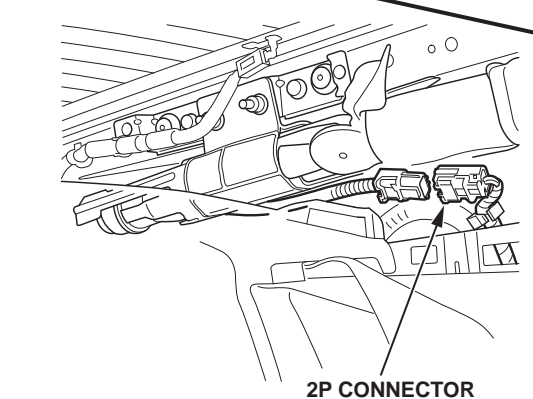

20. Remove the side curtain airbag mounting bolts from the bracket. Detach the clips, then remove the side curtain airbag.
21. Place the new side curtain airbag assembly on the driver's side of the roof, and attach it to the roof by installing the clips in the holes.

22. Tighten the mounting bolts and the side curtain airbag mounting bolts.

- Mounting bolts - **5 N·m (4 lb-ft)**
- Side curtain airbag mounting bolts - **11 N·m (8 lb-ft)**

4-DOOR

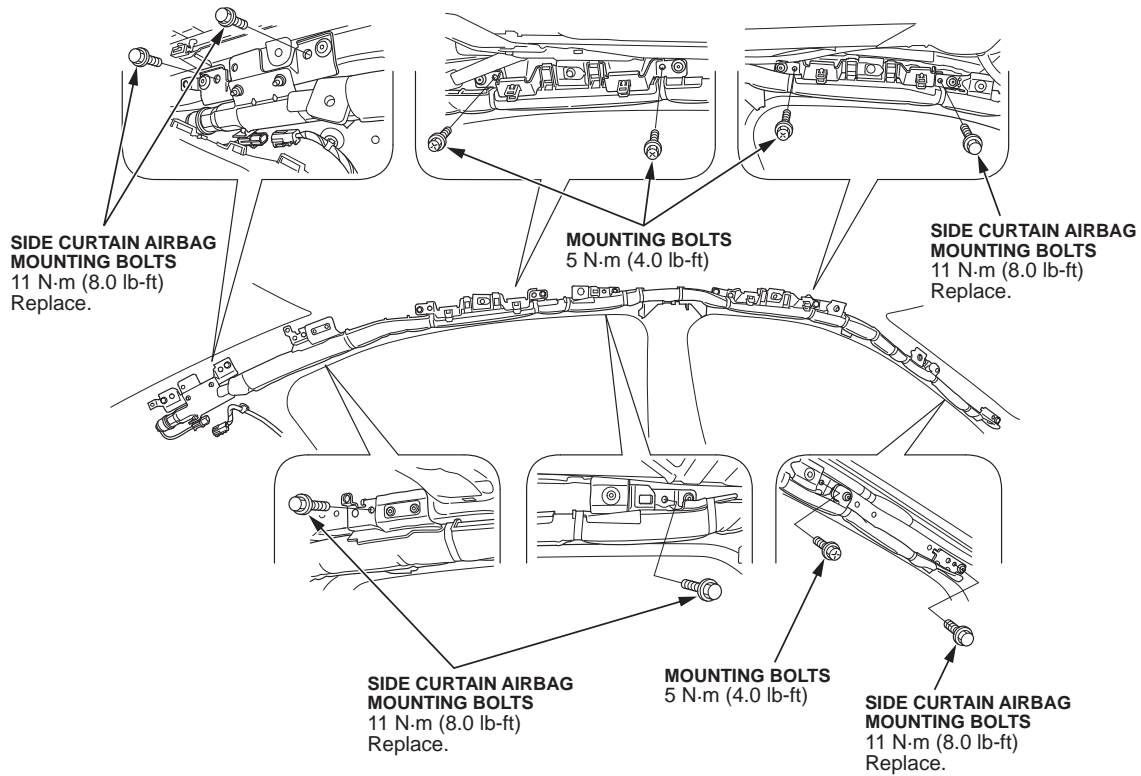

2-DOOR

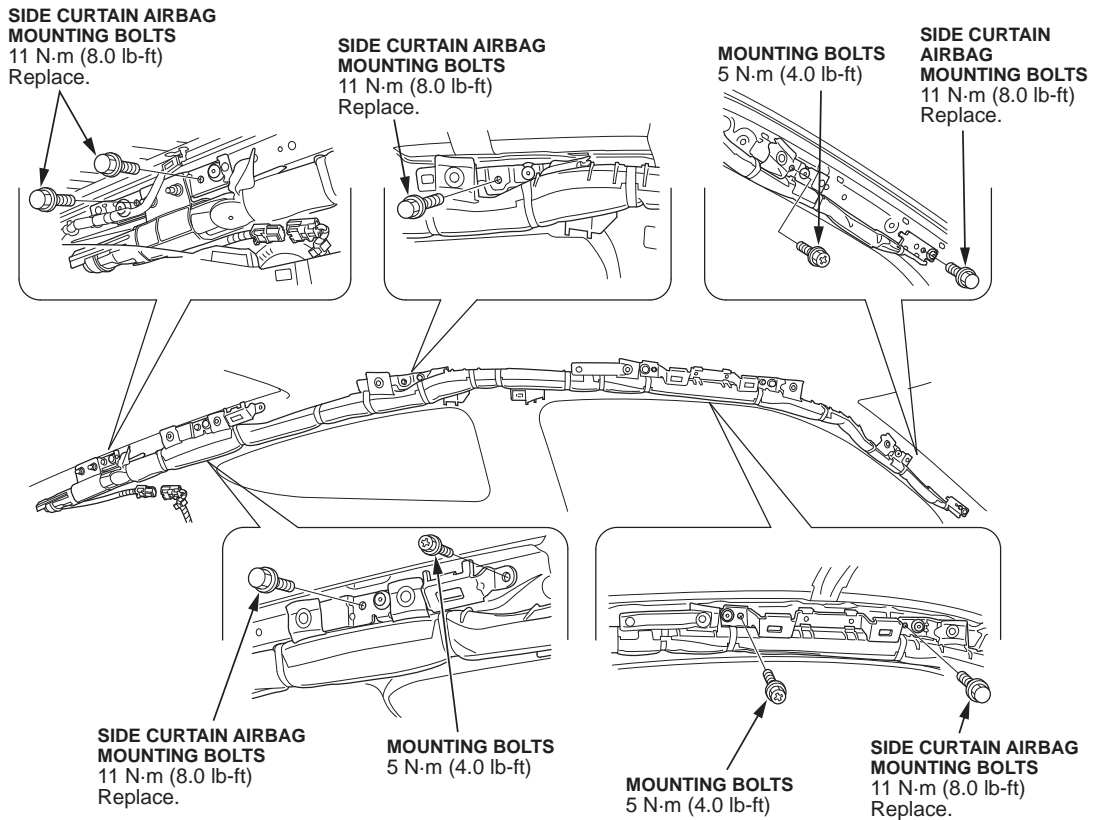

23. Reconnect the SRS floor wire harness.
24. Do the battery terminal reconnection procedure.
25. Clear any DTCs with the HDS.
26. Confirm the proper system operation by turning the ignition switch to ON (II), and check that the SRS indicator comes on for about 6 seconds, then goes off.
27. Place the headliner in the vehicle through the same door that you removed it from.
28. Reattach the roof harness to the headliner.
29. Reinstall the headliner.
30. Reinstall the roof console.
 - Install the roof console screw grommets on the console with the screws.
 - If equipped, connect the navigation microphone connector or the front active noise cancellation microphone.
 - Set the rear hooks, and fit the grommets into the holes in the body, then push up on the console until the grommets snap into place securely.
31. Reconnect the AM/FM antenna lead.
32. Reinstall these items:
 - Passenger's side kick panel
 - Driver's and passenger's A-pillar trim with new clips
 - Driver's and passenger's upper B-pillar trim
 - Driver's and passenger's lower B-pillar trim (4-door)
 - Driver's and passenger's C-pillar trim with new clips (4-door)
 - Driver's and passenger's sunvisors and holders
 - Grab handles (two on 2-door, four on 4-door)
 - Glove box
 - Ceiling light
33. Check and, if necessary, adjust the headliner/pillar trim overlap.
34. *4-door*: Reinstall the driver's seat, and torque the bolts to **41 N·m (30 lb-ft)**.
35. Reinstall the front seat lower anchor bolts, and torque them to **32 N·m (24 lb-ft)**.
36. Center-punch a completion mark above the first character of the engine compartment VIN:

Center-punch here.



REPAIR PROCEDURE – CROSSTOUR

NOTE: This procedure is an outline form that you can also use as a checklist for the repair. If you need more details on the procedures listed below, bookmark them in the *2010–2012 Crosstour Service Manual*, or view them online:

- Front Seat Removal/Installation
- Battery Terminal Disconnection and Reconnection
- Headliner Removal/Installation
- Trim Removal/Installation - Door Areas
- Trim Removal/Installation - Pillar Areas
- Rear Seat Belt Replacement
- Sunvisor Removal/Installation
- Grab Handle Removal/Installation
- Glove Box Removal/Installation
- Ceiling Light Test/Replacement
- Rearview Mirror Replacement
- Side Curtain Airbag Replacement
- Component Replacement/Inspection After Deployment
- General Troubleshooting Information

NOTE: Don't deploy the airbag. WPI will contact your dealership to arrange for the return of the airbag.

1. Remove the front seat lower anchor from the driver's seat.
2. Slide the front seats all the way back, and recline the seat-backs fully.
3. Do the battery terminal disconnection procedure, and wait 3 minutes before starting work.
4. Remove these items:
 - Passenger's side kick panel
 - Driver's and passenger's A-pillar trim
 - Driver's and passenger's upper B-pillar trim
 - Driver's and passenger's lower B-pillar trim
 - Driver's and passenger's quarter pillar trim
 - Both rear passenger seatbelts
 - Driver's and passenger's sunvisors and holders
 - Grab handles (four)
 - Glove box
 - Ceiling light
5. Remove the roof console.
6. If the vehicle is equipped with an automatic dimming mirror, remove the rearview mirror harness cover. Disconnect the connector from the rearview camera, and release the wire harness from the rearview mirror harness cover base.

7. If necessary, remove the roof console screw grommet by pinching out the hooks.
8. If necessary, release the hooks by prying out the map light clip, then remove the clip.
9. Disconnect the four harness clips that secure the roof wire harness to the driver's side A-pillar.
10. Remove the antenna lead at the dashboard side:
 - Detach the four harness clips from the passenger's side A-pillar.
 - From under the passenger's side of the dash, disconnect and detach the antenna lead connector, and detach the harness clip.
11. Disconnect the antenna lead connector and clip from the right quarter pillar area. If necessary, disconnect the GPS subharness connector.
12. Disconnect the moonroof subharness connector and detach the harness clip.
13. Lower the headliner.
 - Remove the front and rear door opening seals from the roof areas.
 - With the help of an assistant, detach the rear headliner clips by pulling down on the rear area of the headliner.
 - Detach the front clips, the magnets, and the hook and loop fasteners by lowering the moonroof opening edge of the headliner.
14. Detach the roof wire harness from the headliner by carefully peeling back just enough tape to remove the harness.

NOTE:

- Don't remove all of the tape; it will be reused.
- Make sure the roof harness is out of the way so it doesn't get tangled with the headliner when you remove it from the vehicle.

- Leave the AM/FM antenna lead attached to the headliner.

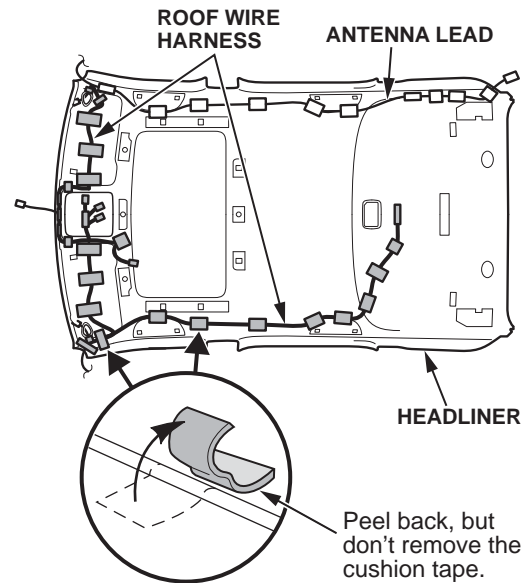

15. With the help of an assistant, pull the headliner out through the tailgate opening.

NOTE: Don't bend the headliner. Bending the headliner will crease and damage it.
16. Remove the front and rear grab handle bracket on the left side.
 - Remove the bolts.
 - Detach the clips.
 - Release the tabs holding the grab handle bracket to the side curtain airbag.
17. Disconnect the SRS floor wire harness 2P connector from the driver's side curtain airbag.

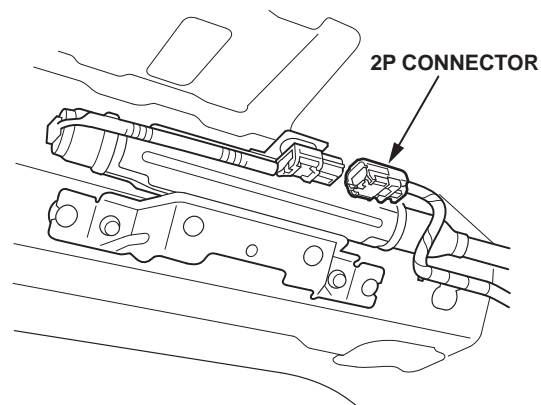

18. Remove the side curtain airbag mounting bolts from the bracket. Detach the clips, then remove the side curtain airbag.
19. Place the new side curtain airbag assembly on the driver's side of the roof, and attach it to the roof by installing the clips in the holes.

20. Tighten the mounting bolts and the side curtain airbag mounting bolts.

- Mounting bolts - **4.4 N·m (3.2 lb-ft)**
- Side curtain airbag mounting bolts - **11 N·m (8 lb-ft)**

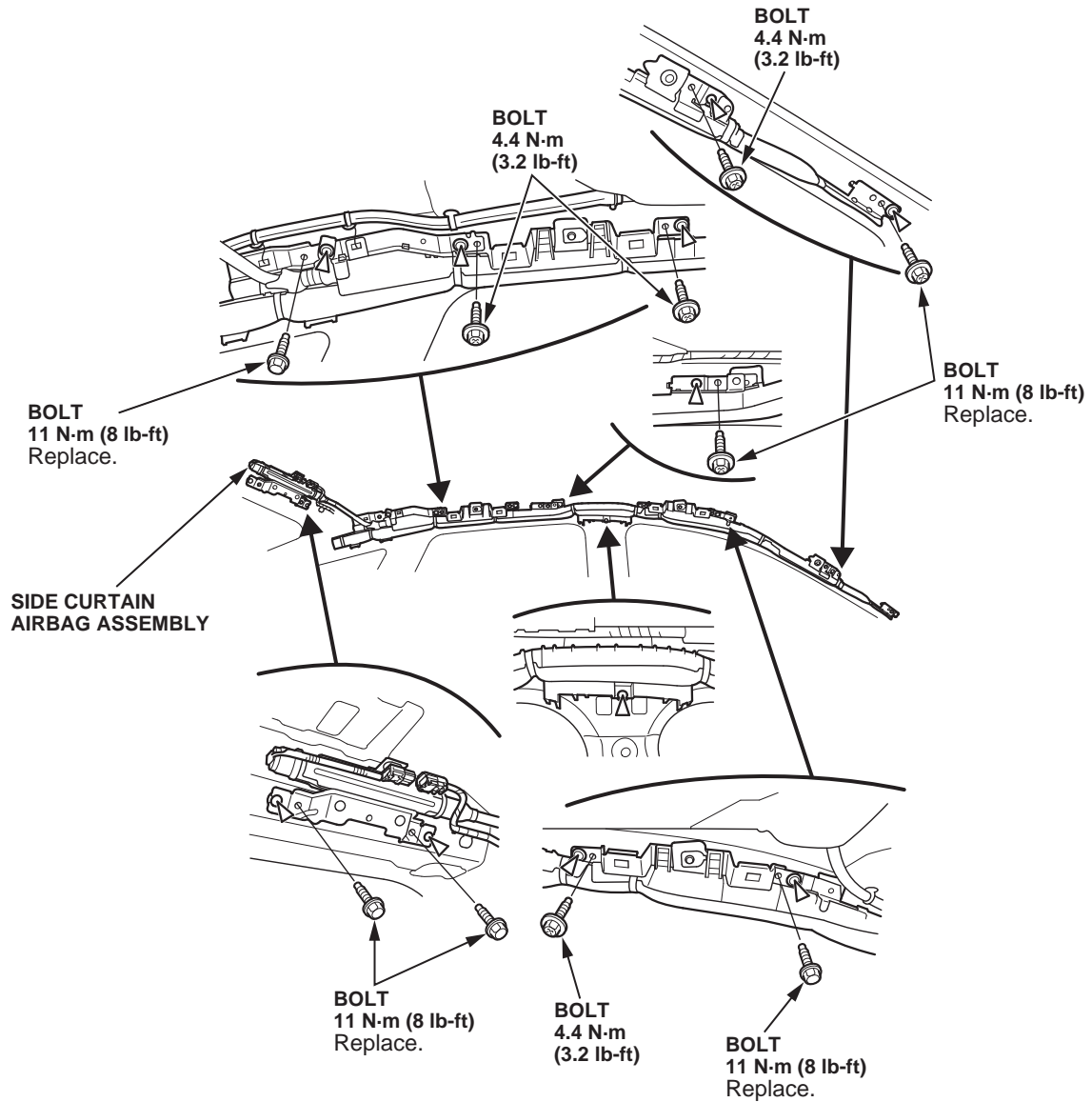

21. Reconnect the SRS floor wire harness.
22. Reinstall the front and rear grab handle brackets. Take care not to damage the side curtain airbag.
 - Torque bolts 1 and 2 to **4.4 N·m (3.2 lb-ft)**
 - Torque bolt 3 to **11 N·m (8 lb-ft)**

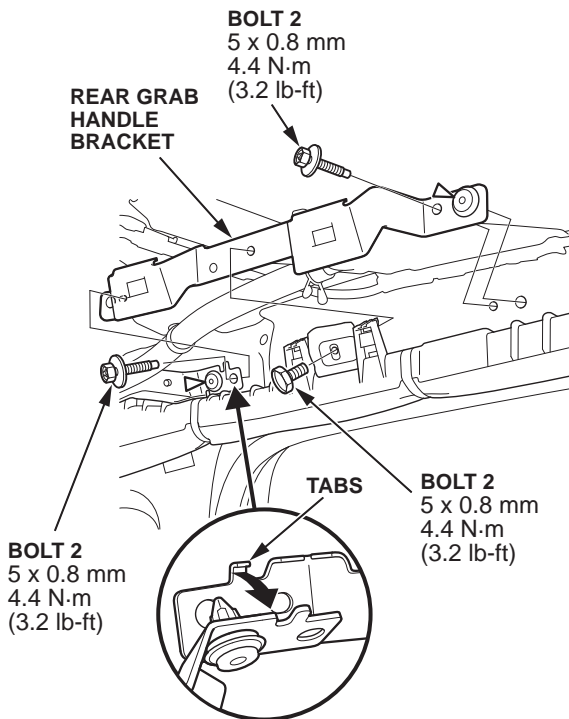
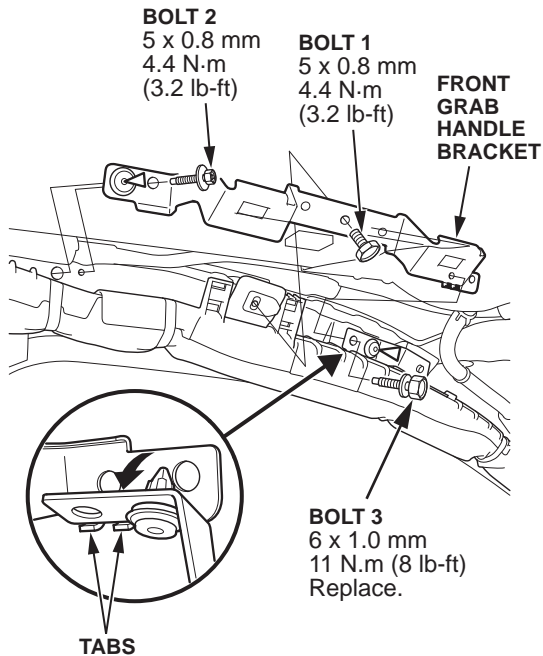

23. Do the battery terminal reconnection procedure.
24. Clear any DTCs with the HDS.

25. Confirm the proper system operation by turning the ignition switch to ON (II), and check that the SRS indicator comes on for about 6 seconds, then goes off.
26. Place the headliner in the vehicle through the tailgate opening.
27. Reattach the roof harness to the headliner.
28. Reinstall the headliner.
29. Reinstall the roof console.
 - Install the roof console screw grommets on the console with the screws.
 - If equipped, connect the navigation microphone connector or the front active noise cancellation microphone.
 - Set the rear hooks, and fit the grommets into the holes in the body, then push up on the console until the grommets snap into place securely.
30. Reconnect the AM/FM antenna lead.
31. Reinstall these items:
 - Passenger's side kick panel
 - Driver's and passenger's A-pillar trim with new clips
 - Driver's and passenger's upper B-pillar trim
 - Driver's and passenger's lower B-pillar trim
 - Driver's and passenger's quarter pillar trim
 - Both rear passenger seat belts
 - Driver's and passenger's sunvisors and holders
 - Grab handles
 - Glove box
 - Ceiling light
32. Reinstall the front seat lower anchor bolts, and torque them to **32 N·m (24 lb-ft)**.
33. Check and, if necessary, adjust the headliner/pillar trim overlap.
34. Center-punch a completion mark above the first character of the engine compartment VIN:



February 2012

**Safety Recall: Driver's (Left) Side Curtain Airbag
May Not Deploy – NHTSA Recall 12V-030**

Dear Honda Owner:

This notice is sent to you in accordance with the requirements of the National Traffic and Motor Vehicle Safety Act.

What is the reason for this notice?

Honda has decided that a defect which relates to motor vehicle safety exists in certain 2012 model year Accord or Crosstour vehicles. The driver-side side curtain airbag inflator may not have been manufactured according to correct specifications. In the event of a crash, the side curtain airbag may fail to deploy, increasing the risk of injury.

What should you do?

Call any authorized Honda dealer and make an appointment to have your vehicle repaired. The dealer will replace the driver-side side curtain airbag assembly. The replacement process may be completed in approximately 90 minutes (2-door Accord), 114 minutes (4-door Accord) or 2 hours and 18 minutes (Crosstour); however, your vehicle will need to be at the dealer for a longer period of time. We recommend that you plan to leave your vehicle for half a day to allow the dealer flexibility in scheduling. This work will be done *free of charge*.

Who to contact if you experience problems

If you are not satisfied with the service you receive from your Honda dealer, you may write to:

American Honda Motor Co., Inc.
Honda Automobile Customer Service
Mail Stop 500-2N-7A
1919 Torrance Blvd.
Torrance, CA 90501-2746

If you believe that American Honda or the dealer has failed or is unable to remedy the defect in your vehicle, without charge, within a reasonable period of time (60 days from the date you first contact the dealer for a repair appointment), you may submit a complaint to:

Administrator
National Highway Traffic Safety Administration
1200 New Jersey Ave., SE
Washington, DC 20590

Or call the toll-free Safety Hotline at 888-327-4236 (TTY 800-424-9153), or go to <http://www.safercar.gov>.

Lessor Information

Federal law requires that any vehicle lessor receiving this recall notice must forward a copy of this notice to the lessee within 10 days.

If you have questions

If you have any questions about this notice, or need assistance with locating a Honda dealer, please call Honda Automobile Customer Service at 1-800-999-1009, and select option 4. You can also locate a dealer online at Honda.com.

We apologize for any inconvenience this campaign may cause you.

Sincerely,

**American Honda Motor Co., Inc.
Honda Automobile Division**