



**TO:** All Mazda Dealership General Managers, Service Managers, and Parts Managers  
**DATE:** June 2012  
**SUBJECT:** 2001-2002 Tribute - ABS Connector Voluntary Safety Recall 6712A

Mazda Motor Corporation has decided that a defect which relates to motor vehicle safety exists in certain 2001-2002 Tribute vehicles equipped with ABS produced from April 20, 2000 through July 19, 2002.

Some affected vehicles may have a master cylinder reservoir cap that could allow brake fluid to leak from the reservoir and potentially reach the ABS module connector. If the module connector is not sealed properly, brake fluid may enter the module connector, creating a potential for an electrical short. An electrical short might cause an ABS malfunction that would illuminate the ABS warning light, and in some cases, the module may overheat, resulting in burning odor, smoke, and/or fire. This condition could occur either when the vehicle ignition switch is in the OFF position or while the vehicle is being operated.

**Owners of affected vehicles will be notified that parts are now available for this repair, by first class mail beginning the week of June 18, 2012.**

***IMPORTANT***

***If recall 4507C is open, perform the 4507C repairs, then perform repairs for recall 6712A. Be sure to submit warranty claims for BOTH recalls, to ensure the recalls are closed for the vehicle.***

An initial order of ABS Connector Repair Kits (P/N ZZCA-67-SH0) based on a percentage of dealer sales, should arrive at your dealership no later than June 20, 2012.

This package contains important information about Voluntary Safety Recall 6712A:

Attachment I	Parts and Service Information
Attachment II	Repair Procedure



-Page 2-

To help you effectively perform this recall, Mazda has developed the following resources:

1. Service and Parts recall instructions (Attachment I) were emailed to your Service Department, and are also available on eMDCS and MS3 (Mazda Service Support System) via MXConnect.
2. The repair procedure (Attachment II) is also available on eMDCS and MS3 (Mazda Service Support System) via MXConnect.
3. We recommend using the Recall Reminder Report #JS30R165-1 and Recall Reminder Labels available in Web Reporting to encourage customers to come in for the recall (with recall reminder postcards). Dealers may use such owner information for the sole purpose of conducting and performing this recall, and for no other purpose. **Using it for marketing activities is strictly prohibited and could subject your dealership to serious fines.** The information in the report is protected by state privacy and other applicable laws regarding disclosure of personal and/or confidential, restricted or blocked information. It is the dealer's responsibility to protect the confidentiality of owner records and prevent the release of information to other parties.
4. Mazda has developed a special web-based parts ordering application for this recall. Dealers will use this new web application exclusively to order parts for the recall only. We will send a separate communication to all dealers, with information regarding this recall 6712A parts ordering application, prior to customer notification.
5. For technical assistance, contact the Technical Assistance Hotline at (888) 832-8477, Option 3 for English speaking Hotline Specialist, Option 4 for Spanish speaking Hotline Specialist.
6. For warranty questions, contact the Warranty Hotline at (877) 727-6626, Option 3.
7. For parts questions, contact the Corporate Dealer Assistance Group at (877) 727-6626, Option 2.

Please make certain the appropriate personnel in your dealership are aware of these resources and are familiar with the details of this recall before responding to customer inquiries.

We apologize for any inconvenience this recall may cause you and your customers. Your understanding and support in carrying out this campaign is greatly appreciated.

Sincerely,

Satoshi Takahashi  
Director, Technical Services Division  
Mazda North American Operations

**CONDITION OF CONCERN**

Some affected vehicles may have a master cylinder reservoir cap that could allow brake fluid to leak from the reservoir and potentially reach the ABS module connector. If the module connector is not sealed properly, brake fluid may enter the module connector, creating a potential for an electrical short. An electrical short might cause an ABS malfunction that would illuminate the ABS warning light, and in some cases, the module may overheat, resulting in burning odor, smoke, and/or fire. This condition could occur either when the vehicle ignition switch is in the OFF position or while the vehicle is being operated.

***If recall 4507C is open:***

- 1. Perform recall 4507C repairs.***
- 2. Perform the attached repairs for recall 6712A.***
- 3. Submit warranty claims for BOTH recalls, to ensure the recalls are closed for the vehicle.***

**SUBJECT VEHICLES**

<b>Model</b>	<b>VIN Range</b>	<b>Build Date Range</b>
Certain 2001-2002 MY Tributes equipped with ABS	4F2 *U****1K M00212 - M67335 and 4F2 *U****2K M00002 - M66656	From April 20, 2000 through July 19, 2002

Note: The asterisk symbol "\*" can be any letter or number.

**OWNER NOTIFICATION**

Mazda will notify U.S. owners by first class mail beginning the week of June 18, 2012.

**PARTS INFORMATION**

<b>Description</b>	<b>Part Number</b>	<b>Quantity</b>	<b>Notes</b>
ABS Connector Repair Kit	ZZCA-67-SH0	1	Kit Components: <ul style="list-style-type: none"> <li>• Jumper wire assembly – 1 pc</li> <li>• Brake master cylinder reservoir cap</li> <li>• Black adhesive dots (stickers) -2 pcs</li> <li>• Fused ABS relay – 1 pc</li> <li>• Electrical wire (for splicing)</li> <li>• 3M Adhesive promoter 4298</li> <li>• Tie Strap – 1 pc</li> </ul>
Campaign Label	9999-95-065A-06	1=50 labels	Obtain in MStore (no charge)

**PARTS PRE-SHIPMENT**

An initial order of ABS Connector Repair Kits (P/N ZZCA-67-SH0) based on a percentage of dealer sales, should arrive at your dealership no later than June 20, 2012.

**PARTS ORDERING – WEB PAGE ORDER INSTRUCTIONS**

Mazda has developed a new web-based application for automated ordering of Recall 6712A repair kits. Mazda will send a separate notice to all dealers with instructions for using this web application.

Contact Mazda's Dealer Assistance Group at (877) 727-6626, Option 2 with any questions regarding this ordering process.

**WARRANTY CLAIM PROCESSING INFORMATION**

<b>Installation of ABS Connector Repair Kit</b>	
Warranty Type	<b>R</b>
Symptom Code	99
Damage Code	99
Process Number	<b>J1203A</b>
Part Number Main Cause	ZZCA-67-SH0
Quantity	1
Labor Operation Number	YY740XRX
Labor Hours	0.5 hrs

**RENTAL CAR INFORMATION**

Rental car reimbursement is not authorized for this recall. Affected vehicles are not within the time limitations under the Rental Car Reimbursement Program, Section 12.0.

**VERIFY THE VEHICLE NEEDS THE RECALL**

1. Verify the vehicle is within the following ranges:

<b>Model</b>	<b>VIN Range</b>	<b>Build Date Range</b>
Certain 2001-2002 MY Tributes equipped with ABS	4F2 *U****1K M00212 - M67335 and 4F2 *U****2K M00002 - M66656	From April 20, 2000 through July 19, 2002

If the vehicle is within the above range, go to step 2.

If the vehicle is not within the above range, return it to the customer.

**ATTACHMENT I –PARTS AND SERVICE INFORMATION**  
**Safety Recall 6712A**

2. Perform a Warranty Vehicle Inquiry using your eMDCS System and inspect vehicle for an Authorized Campaign Label RECALL 6712A and 4507C attached to the vehicle's hood or bulkhead.

**eMDCS System - Vehicle Status Inquiry Results**

<b>If eMDCS displays:</b>	<b>Campaign Labels</b>	<b>Action to perform:</b>
Recall 4507C OPEN	Present	Contact the Warranty Hotline at (877) 727-6626, option 3, to update vehicle history
	Not present	Refer to Recall 4507C 2001-2004 Tribute Anti-Lock Brake System, and then continue with Recall 6712A repair instructions
Recall 6712A OPEN	Present	Contact the Warranty Hotline at (877) 727-6626, option 3, to update vehicle history
	Not present	Proceed to Recall 6712A Repair Procedure
Recall 6712A and Recall 4507C CLOSED	Present	Return vehicle to inventory or customer.
	Not present	Complete a label and apply to vehicle's hood or bulkhead.
Recall 6712A and 4507C are not displayed	Does not apply	Recall does not apply to this vehicle. Return vehicle to inventory or customer.

**NOTE:** Verify the recall number, as the vehicle may have multiple labels.

**REPAIR PROCEDURE**

Please refer to Attachment II.

**2001-2002 TRIBUTE - ABS RELAY INSTALLATION AND MASTER CYLINDER RESERVOIR CAP REPLACEMENT [RECALL 6712A]**

**A. VEHICLE INSPECTION PROCEDURE**

1. Verify that the vehicle is within one of the following ranges:

Model	VIN Range	Build Date Range
Certain 2001 - 2002 Tribute vehicles equipped with ABS	VIN Range: 4F2*U**** 1K M00212 - M67335 VIN Range: 4F2*U**** 2K M00002 - M66656	From April 20, 2000 through July 19, 2002

- If the vehicle is within the above range, proceed to Step 2.
- If the vehicle is not within the above range, refer to Voluntary Safety Recall 4507C 2001-2004 Tribute Anti-Lock Brake System.
- If the vehicle is not within the above or Recall 4507C range, return the vehicle to the customer or inventory.

2. Perform a Warranty Vehicle Inquiry using your eMDCS System and inspect vehicle for both Campaign Labels **Recall 6712A** and **Recall 4507C** attached to the vehicle’s hood or bulkhead. Refer to eMDCS System - Warranty Vehicle Inquiry Results table below.

**NOTE:** Be sure to verify Recall number as the vehicle may have multiple Recall labels.

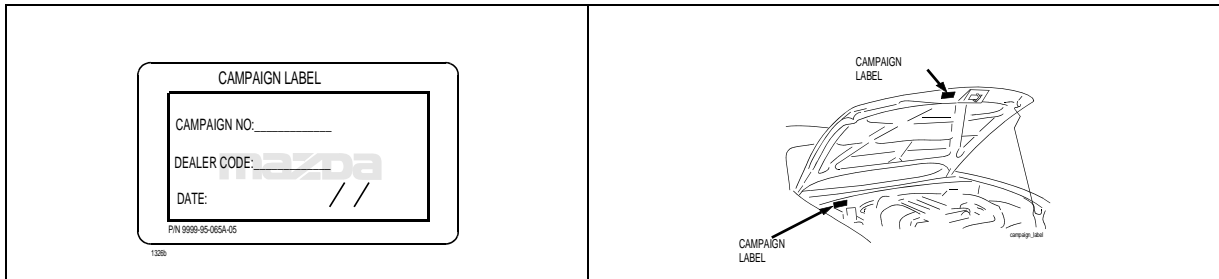

**eMDCS System - Warranty Vehicle Inquiry Results:**

If eMDCS displays:	Campaign Labels are:	Action to perform:
Recall 4507C OPEN	Present	Contact the Warranty Hotline at (877) 727-6626, option 3, to update vehicle history.
	Not present	Refer to Recall 4507C 2001-2004 Tribute Anti-Lock Brake System, and then continue with Recall 6712A.
Recall 6712A OPEN	Present	Contact the Warranty Hotline at (877) 727-6626, option 3, to update vehicle history.
	Not present	Proceed to “B. OVERVIEW” on the next page.
Recall 6712A and 4507C CLOSED	Present	Return vehicle to inventory or customer.
	Not present	Proceed to “D. CAMPAIGN LABEL INSTALLATION”.
Recall 6712A and 4507C are not displayed	Does not apply	Recall does not apply to this vehicle. Return vehicle to inventory or customer.

**NOTE:** If both 4507C and 6712A repairs were performed, submit warranty claims for BOTH recalls, to ensure the recalls are closed for the vehicle.

**B. OVERVIEW**

Some of the affected vehicles may have a master cylinder reservoir cap that could allow brake fluid to leak and potentially reach the ABS module connector. If the module connector is not sealed properly, brake fluid may enter the module connector, creating a potential for an electrical short. An electrical short might cause an ABS malfunction that would illuminate the ABS warning light, and in some cases, the module may overheat resulting in burning odor, smoke, and/or fire. This condition could occur either when the vehicle ignition switch is in the off position or while the vehicle is being operated.

**Dealers are to:**

- ensure Safety Recall 4507C 2001-2004 Tribute Anti-Lock Brake System is completed.
- install a revised brake master cylinder reservoir cap.
- disable the original ABS circuits which were powered at all times.
  - Remove and discard original fuses (reference "A" below).
  - Cut wires that lead to the fuses (reference "B" below).
  - Splice the two red wires together (reference "C" below).
- install a new fused ABS relay to provide "Key-On" power only (reference "D" below).

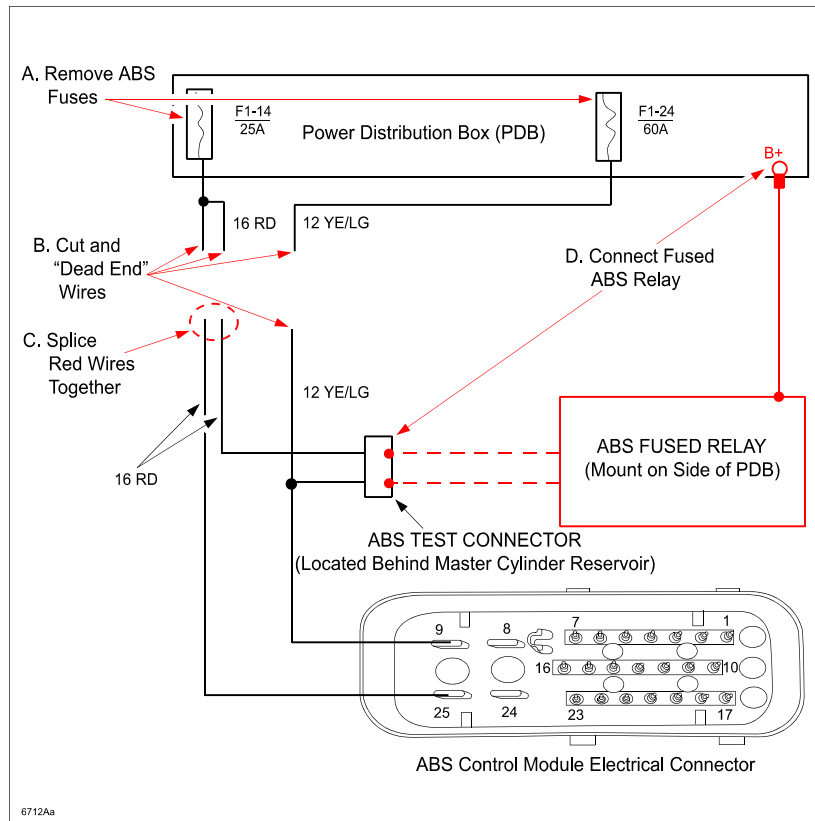

## C. REPAIR PROCEDURE

### Install Revised Brake Master Cylinder Reservoir Cap

1. Remove and discard the brake master cylinder reservoir cap.
2. Install the revised brake master cylinder reservoir cap (A). See Figure 1.

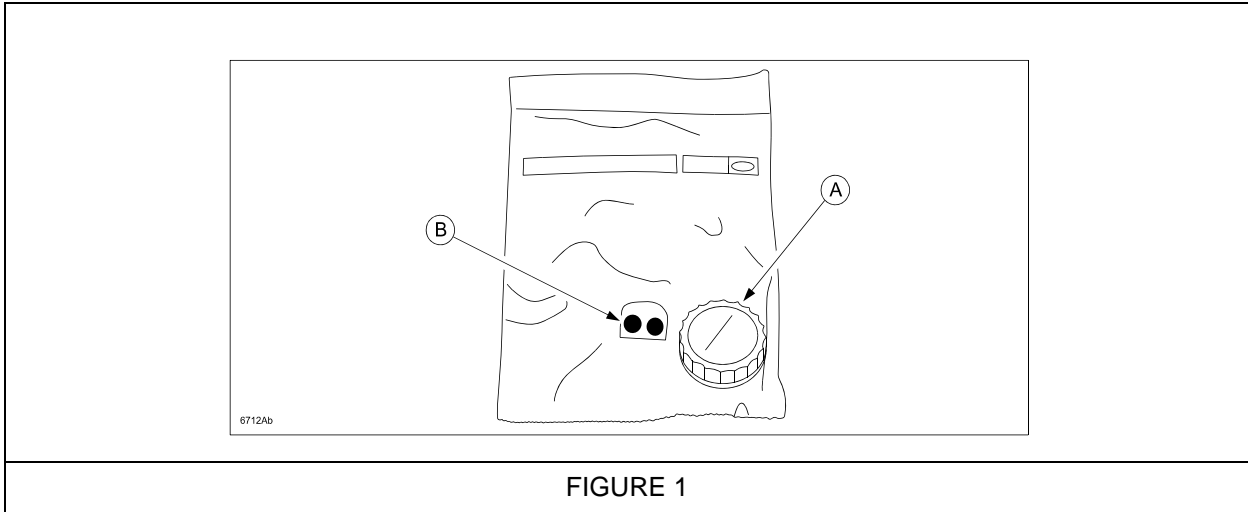

FIGURE 1

**NOTE:** The revised brake master cylinder reservoir cap package also contains two (2) black adhesive dots (B) that will be used in the next step.



**Remove the Original ABS Fuses**

1. Remove the Power Distribution Box (PDB) cover (A). Clean the PDB cover inside label. Apply the two black adhesive dots to the label over fuse location F1.14 and F1.24 (B). See Figure 2.

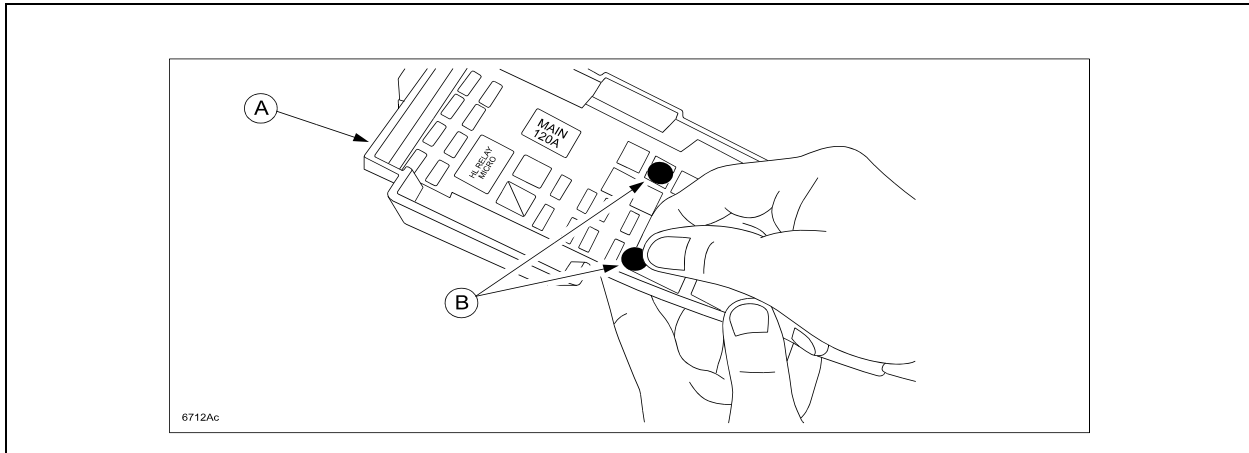

FIGURE 2

2. Ensure fuses F1.14 and F1.24 were removed. If not, remove and discard the 25A fuse from cavity F1.14 (A) and the 60A fuse in cavity F1.24 (B). See Figure 3.

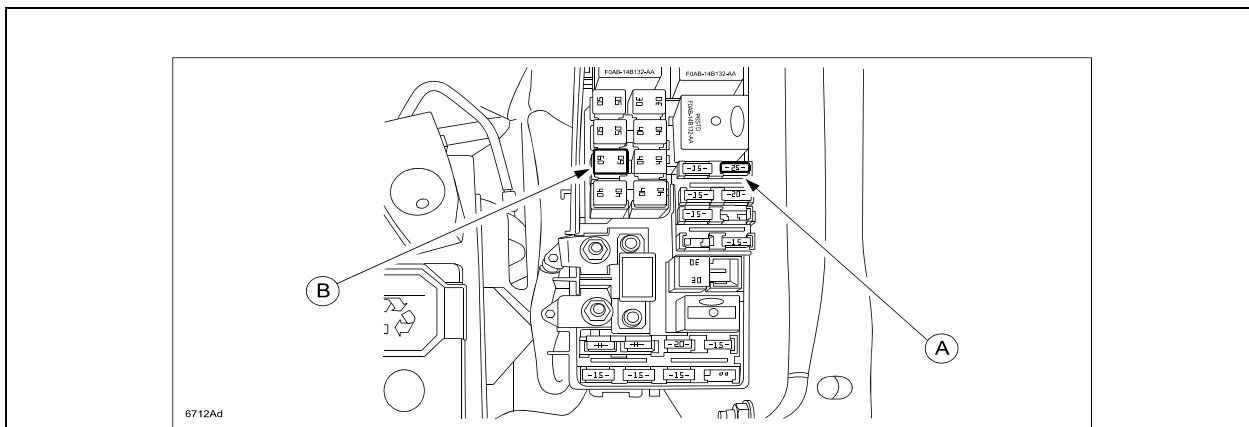
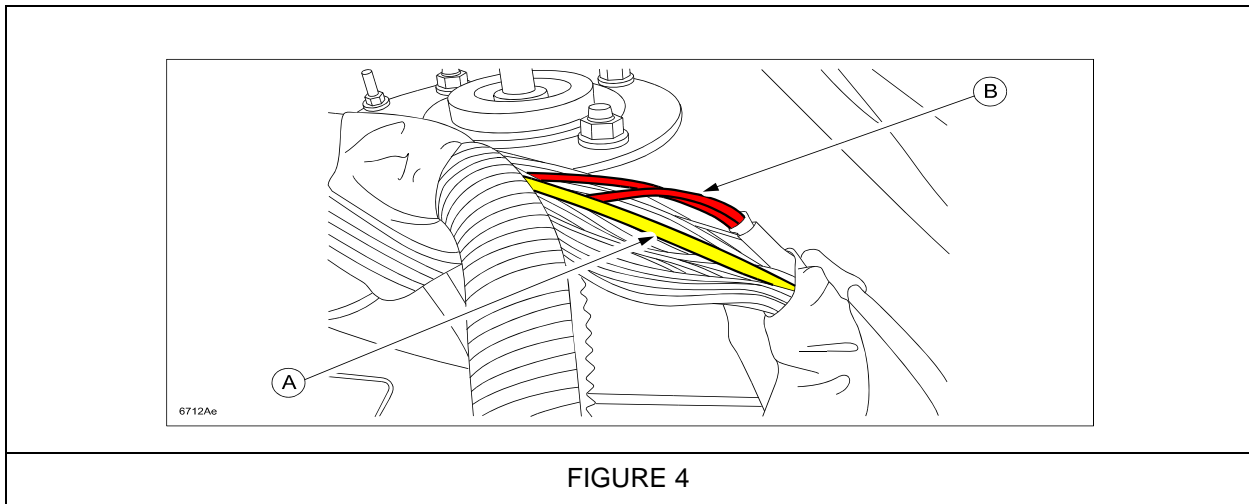

FIGURE 3

### Disable Original ABS Circuits

**NOTE:** In the absence of the 25A and 60A ABS fuses, the ABS fused relay will supply power to the ABS module and is only powered in the "Key-On" position. The circuit would be restored to "powered at all times" if an individual reinstalled the fuses. To prevent this, the original ABS wires that lead to the PDB must be cut and "dead ended".

1. Record radio presets.
2. Disconnect the negative battery cable. For additional information refer to MS3 online or Workshop Manual (section 01-17 BATTERY DISCONNECT).
3. Open the wire harness loom between the PDB and the tie down strap and locate the 12 gauge Y/LG wire (A). See Figure 4.



4. Locate the two 16 gauge R wires (B) that run next to each other and are factory spliced to a single Red wire near the PDB. See Figure 4.

**NOTE:** Ignore the Red wire that is not factory spliced.

5. Cut the 12 gauge Y/LG wire (A) and the two 16 gauge R wires (B).

- Using a non-insulated butt connector, splice the two 16 gauge R wires (A) together that lead to the ABS module. See Figure 5.

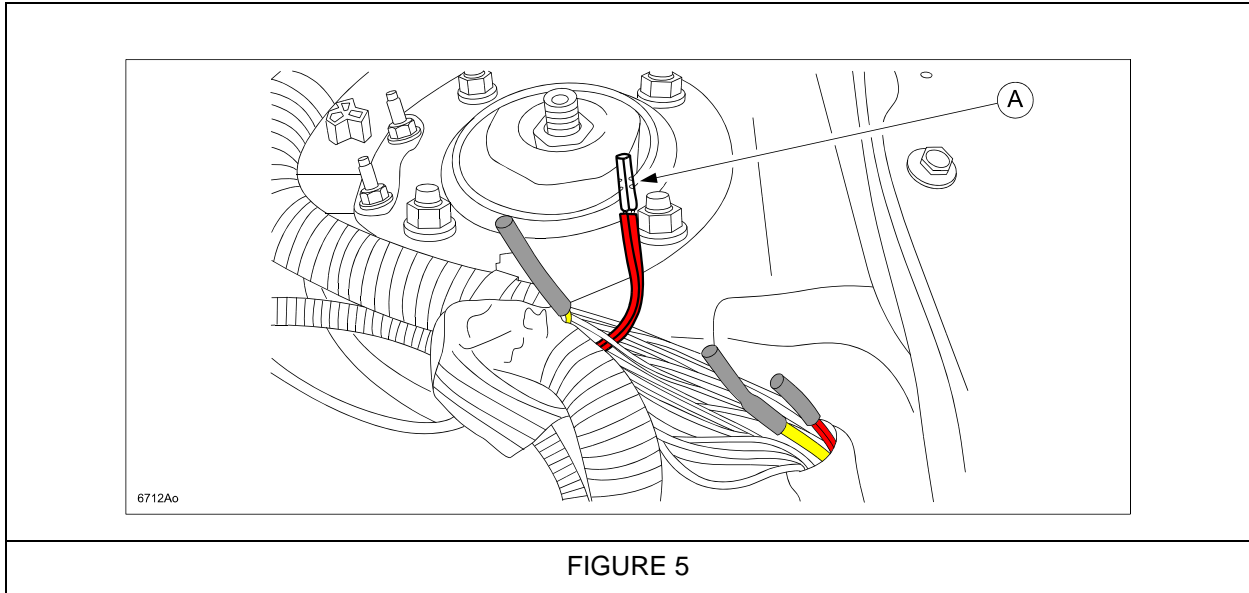

- Apply heat shrink tubing to spliced wires and "dead end" all remaining cut wires by applying heat shrink tubing over the cut end. See Figure 6.

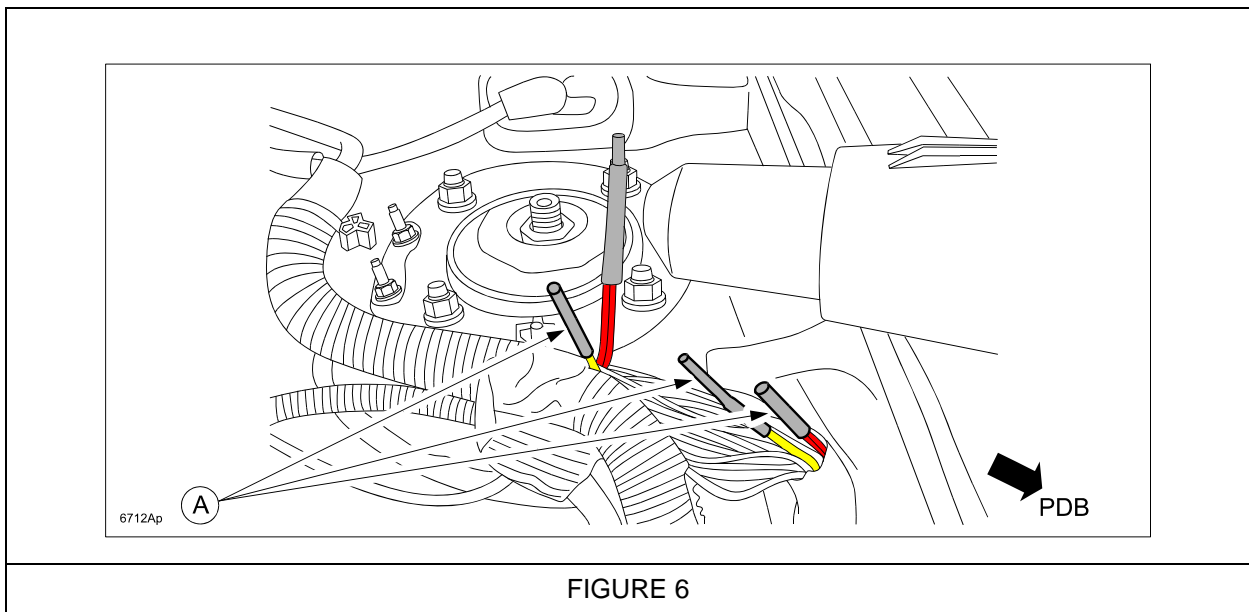

- Secure the wires in the loom and wrap the loom with electrical tape.

**Install ABS Fused Relay**

1. Spray brake cleaner on a clean shop towel and wipe the side of the PDB (A) to remove all traces of oil and dirt. See Figure 7.

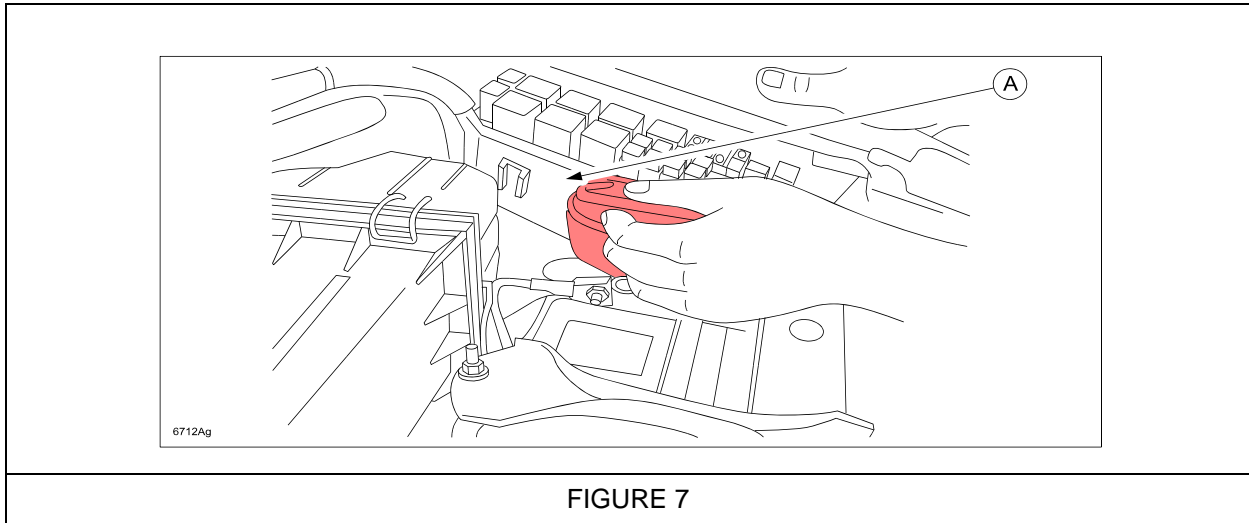

FIGURE 7

2. Wipe the side of the PDB again with a clean dry shop towel.
3. Apply the supplied adhesive promoter (A) to the cleaned area. See Figure 8

**IMPORTANT!:**

- Adhesive promoter is required in order to make a strong bond between the ABS fused relay and PDB.
- The adhesive promoter requires 2 minutes of drying time.

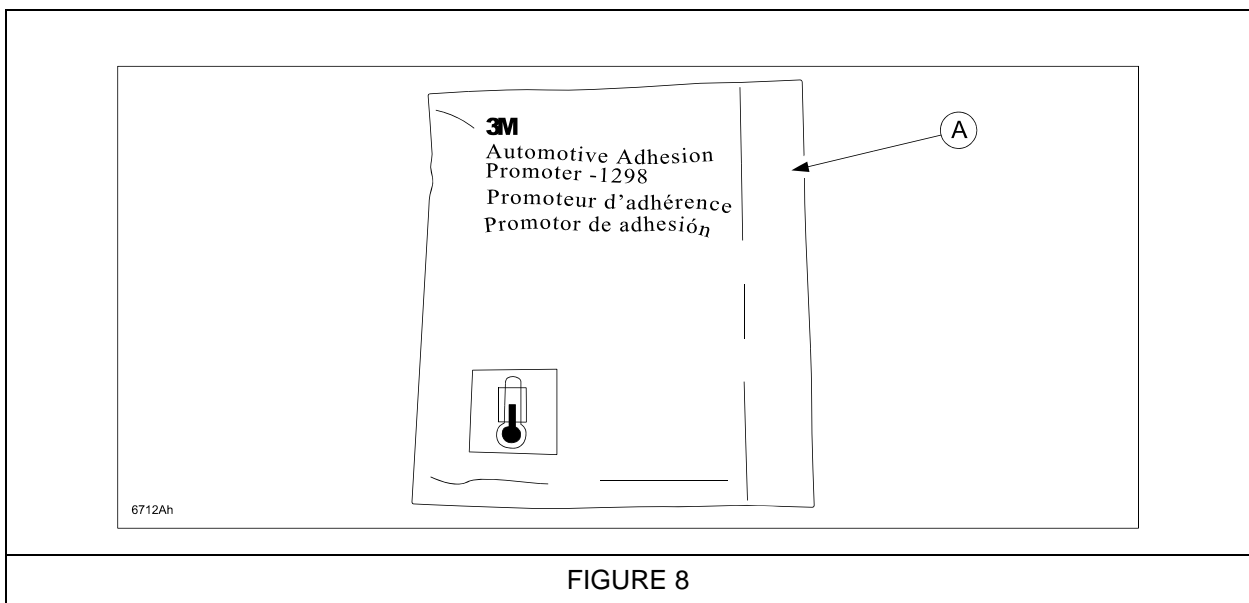

FIGURE 8

4. While the adhesive promoter is drying:
- Position the ABS relay housing (A) next to the PDB. (Do not attach relay to PDB at this time.)
  - Remove the B+ terminal nut (B). See Figure 9
  - Connect the red ABS relay wire eyelet to the B+ terminal inside the PDB. See Figure 9
  - Torque the B+ terminal nut to 10.5 Nm (7.7 lb-ft).

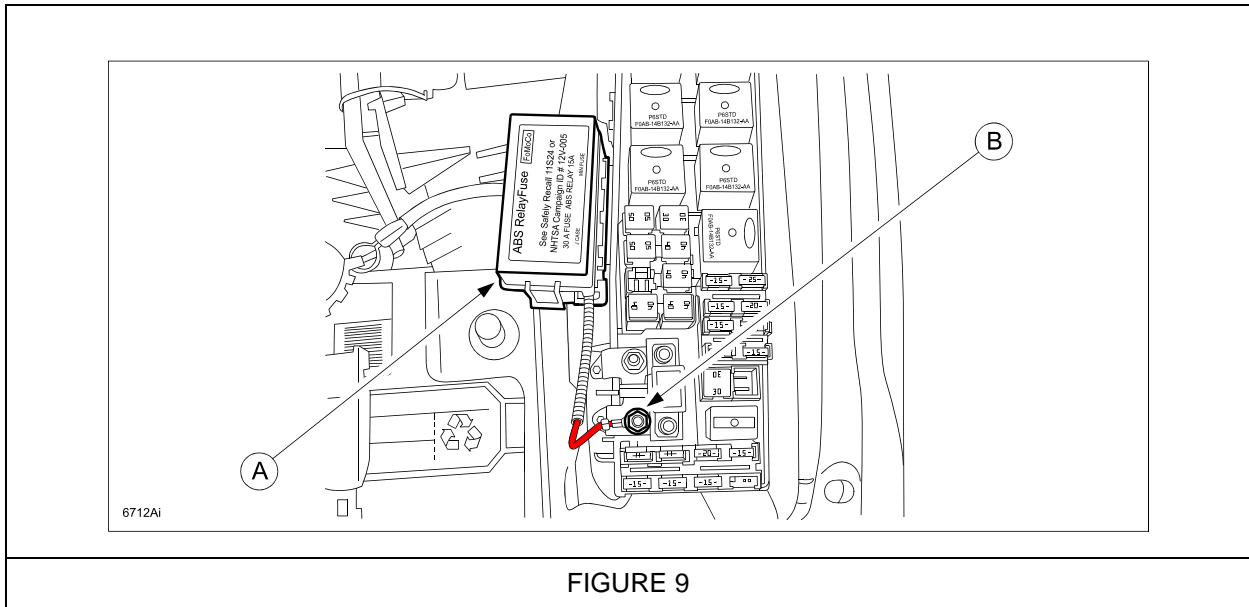

FIGURE 9

5. Locate the ABS test connector (A) mounted behind the master cylinder reservoir (B). Remove and discard the test connector plug and connect the ABS relay connector (C). See Figure 10.

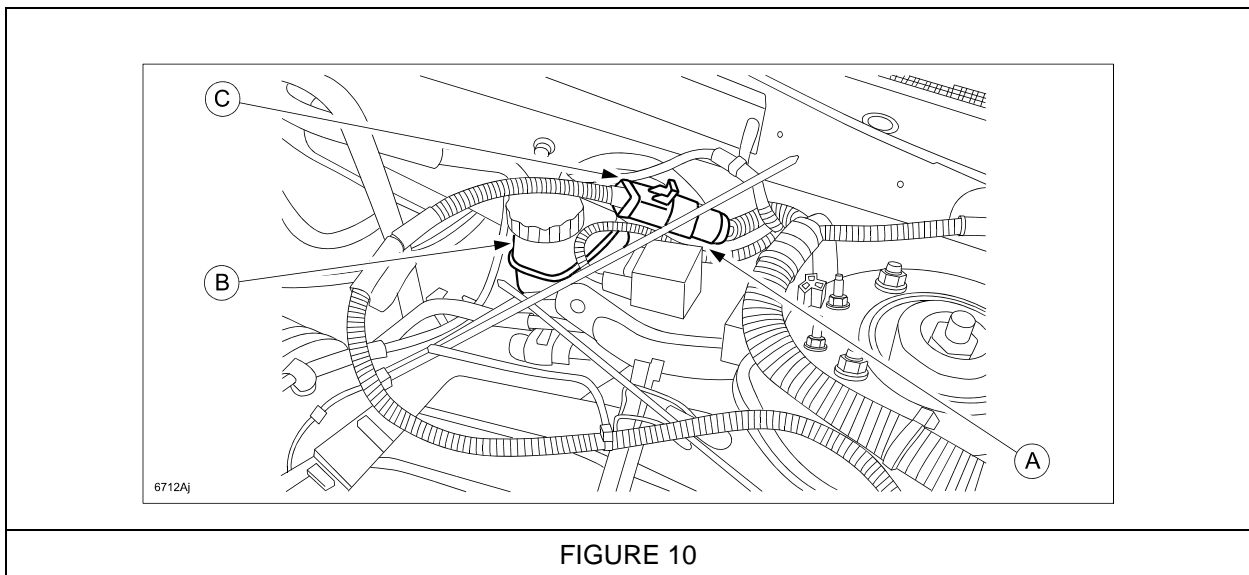

FIGURE 10

- Remove the protective film from the adhesive tape located on the side of the relay housing. Align the top edge of the adhesive tape to the upper edge of the PDB housing (C). Push the relay housing (A) firmly against the area with the dried adhesive promoter of the PDB (B). See Figure 11.

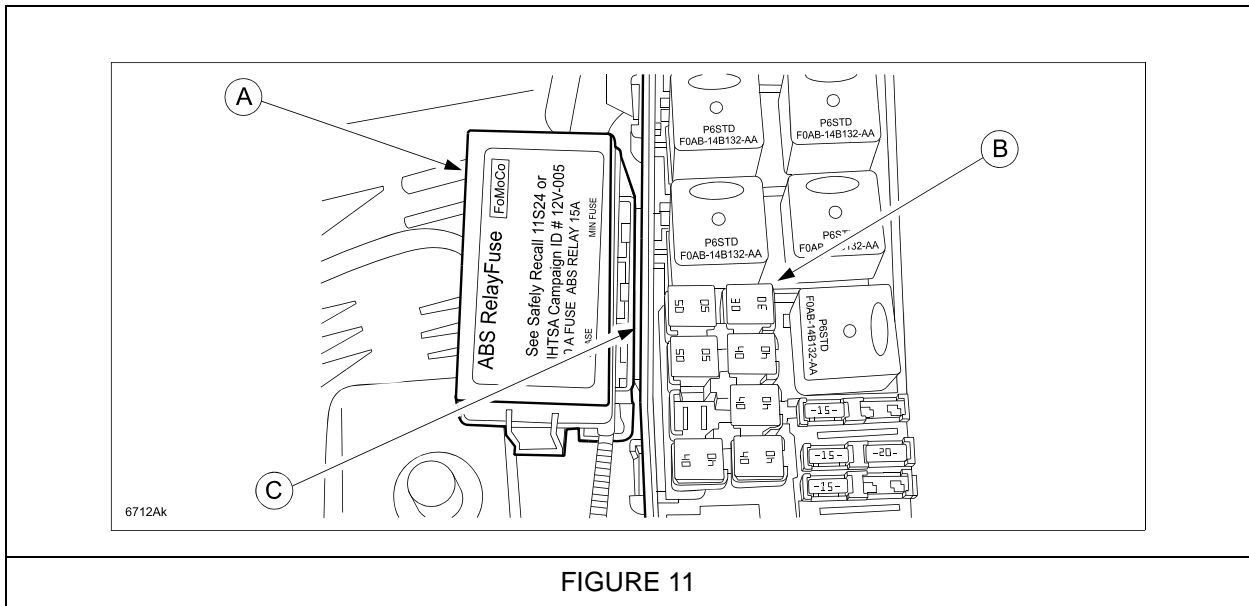

FIGURE 11

- Route the ABS relay harness along the PDB wire harness and secure it with the three attached tie straps. See Figure 12.

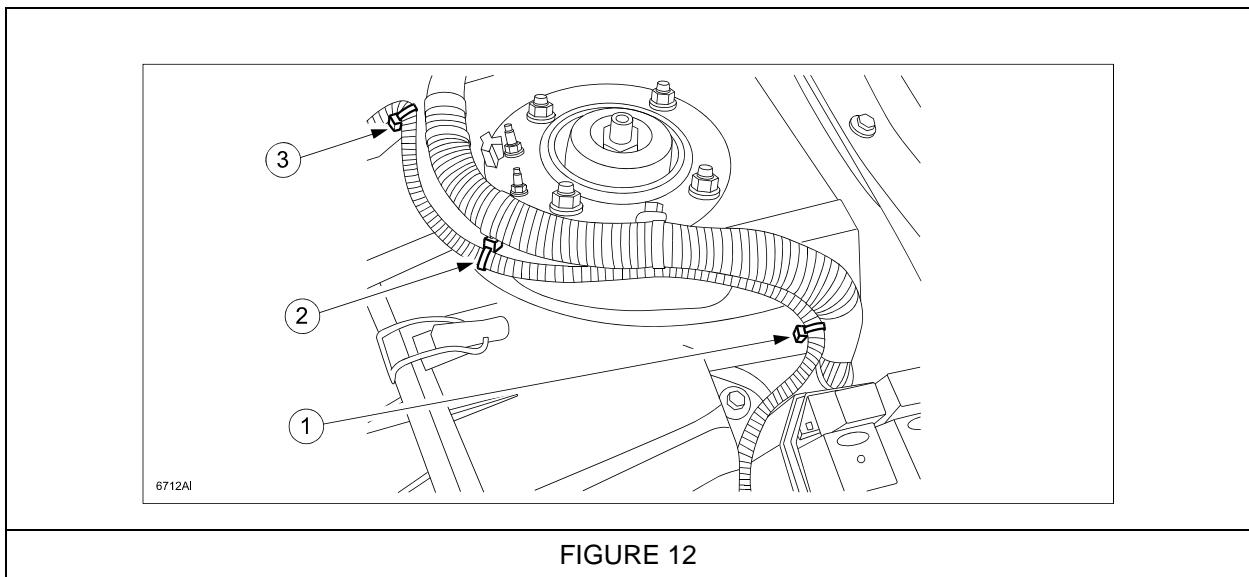
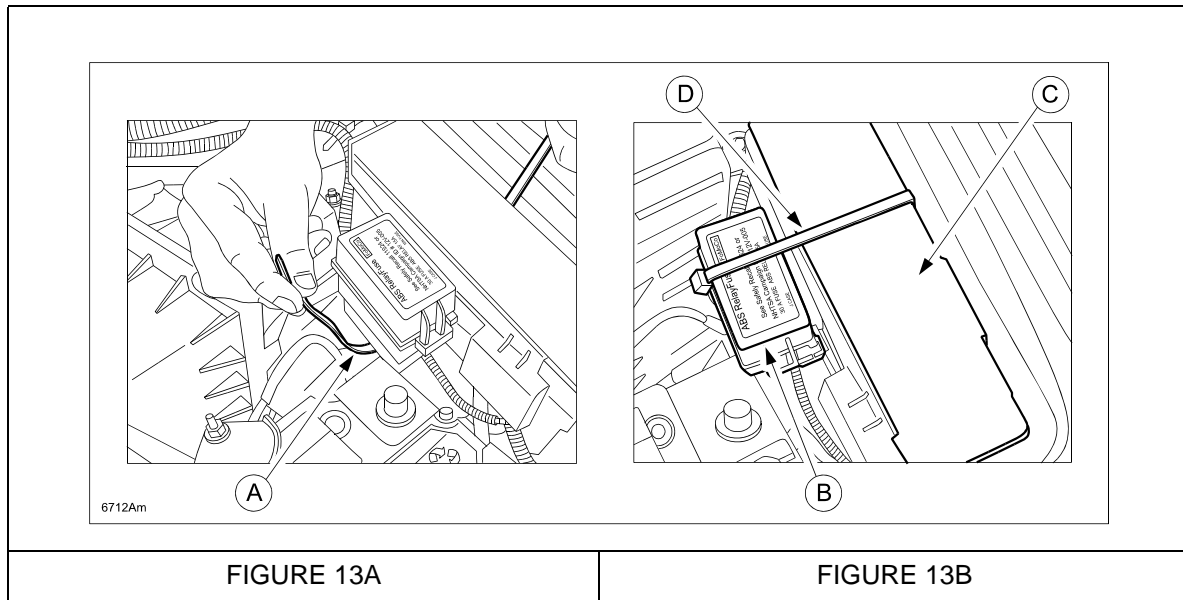

FIGURE 12

8. Reinstall the PDB cover. Bend the male end of the supplied tie strap to ease the installation. Push the tie strap under and around the PDB box (A). See Figure 13A. Secure the ABS relay housing (B) to the PDB (C) by tightening the tie strap (D) around the PDB and the relay housing. See Figure 13B.



9. Connect the negative battery cable. For additional information refer to MS3 online or Workshop Manual (section 01-17 BATTERY DISCONNECT).
10. Reset the clock and radio presets.

**D. CAMPAIGN LABEL INSTALLATION**

1. Fill out a blue “Campaign Label” (9999-95-065A-06) with Campaign No: “6712A”, your dealer code, today’s date.

**CAMPAIGN LABEL**

CAMPAIGN NO: \_\_\_\_\_

DEALER CODE: \_\_\_\_\_

DATE:            // /

P/N 9999-95-065A-06

1326b

2. Affix it to the hood or bulkhead as shown:

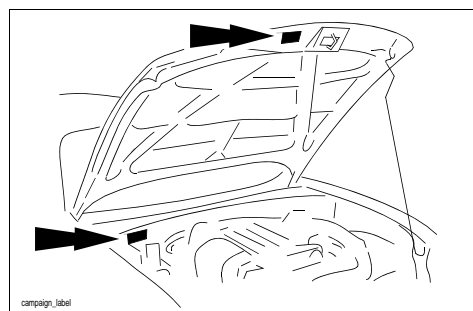

3. Return the vehicle to customer.