	GROUP Campaign	MODEL 2007/08MY Rondo (UN), 2006/08 Optima (MG)
	NUMBER 094	DATE February 2012
<b>SAFETY RECALL CAMPAIGN</b>		
SUBJECT: RONDO & OPTIMA CLOCK SPRING ASSEMBLY REPLACEMENT (SC094)		

This bulletin provides information relating to the replacement of the clock spring assembly in Rondo vehicles produced from September 13, 2006 to March 21, 2008 and Optima vehicles produced from September 29, 2005 to January 29, 2008. There is a possibility that the clock spring contact assembly may become worn over time. If the clock spring contact assembly becomes damaged, it can cause high electrical resistance, which could prevent deployment of the driver's air bag in certain frontal collisions. If this condition occurs, the "AIR BAG" warning lamp will illuminate.

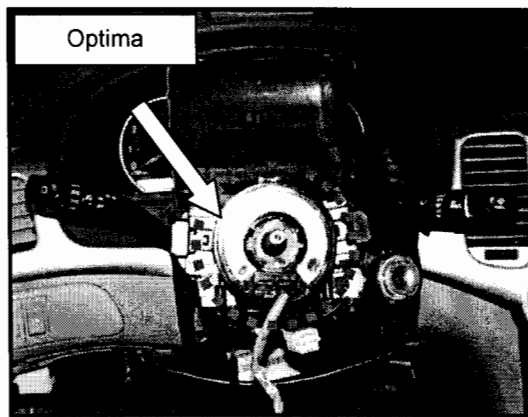
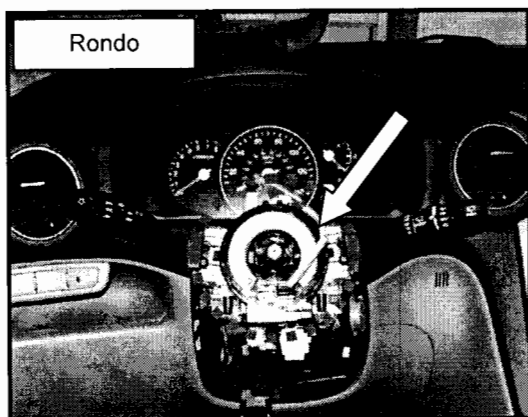

Rondo & Optima Clock Spring Assembly

**★ NOTICE**

“Under applicable law, you may not sell or otherwise deliver any affected 2006-2008MY Kia Optima vehicles or 2007-2008MY Kia Rondo vehicles until it has been repaired pursuant to the procedures set forth in this bulletin.”

For all vehicles potentially subject to this campaign, WebDCS must be checked to confirm that SC094 has not been previously completed, using: WebDCS > Warranty Coverage > Warranty Coverage Inquiry > Check Open Campaign Status.

File Under: <Campaign>

- Circulate To:     General Manager     Service Manager     Parts Manager
- Service Advisor(s)     Technician(s)     Body Shop Manager     Fleet Repair

**\* NOTICE**

To assure complete customer satisfaction, always remember to refer to WebDCS Warranty Coverage (validation) Inquiry Screen (Service>Warranty Coverage>Warranty Coverage Inquiry) for a list of any additional campaigns that may need to be performed on the vehicle before returning it to the customer.

**Rondo / Optima Service Procedure:**

1. Drive vehicle into the shop and make sure the front wheels are pointing straight ahead and the steering wheel is straight and level before performing the service procedure.

**\* NOTICE**

Front wheels and steering wheel must be straight to ensure proper installation of the clock spring assembly.

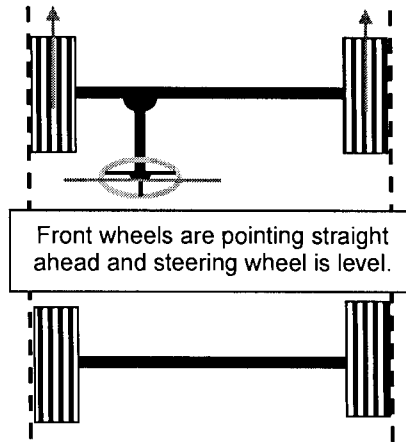

2. Record customer's radio presets, and then disconnect the negative battery cable and wait for at least three minutes before beginning procedure.

Remove the two (2) airbag module mounting bolts (A). **Use a Snap-on FTXL40E or equivalent tool.**

**Airbag Module Mounting Bolts  
Tightening Torque:  
5.8~7.2 lb-ft (7.9~9.8 Nm)**



Rondo

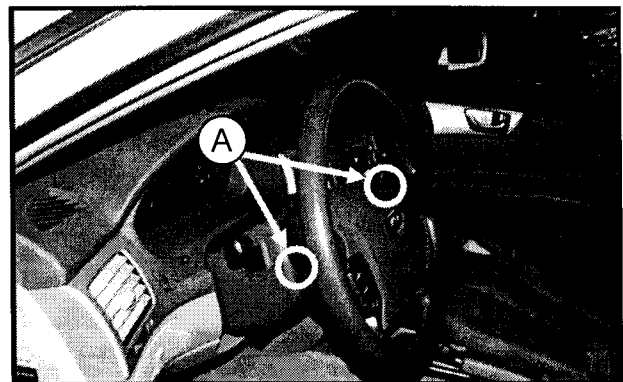

Optima

**SUBJECT: RONDO & OPTIMA CLOCK SPRING ASSEMBLY REPLACEMENT (SC094)**

3. Disconnect the horn connector (B).

Release the connector locking pin, and then disconnect the driver airbag module connector(s) (C).

**\* NOTICE**

When reinstalling the driver air bag module, be sure to securely connect the driver airbag module connector(s) (C). If not, the airbag warning indicator light may stay on.

The removed airbag module assembly should be kept with the pad cover facing upward in a clean and dry location.

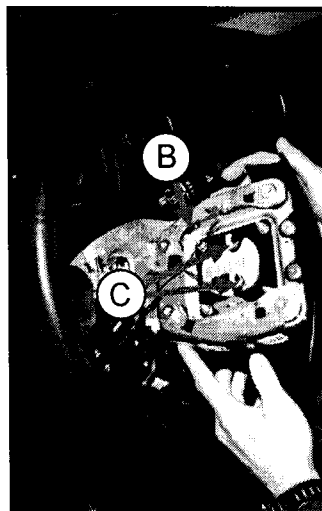

Rondo

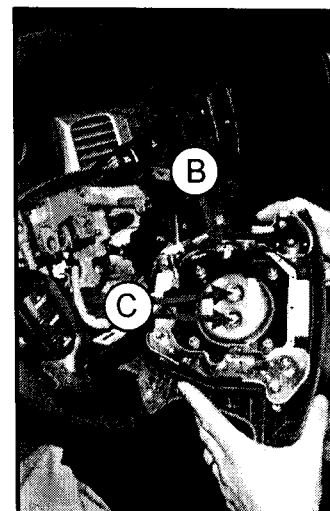

Optima

4. Disconnect the front clock spring connector (D), and then remove the steering wheel mounting nut and spring washer. Paint an alignment mark on steering wheel and shaft before removal.

Remove the steering wheel by using a steering wheel puller.

**Steering Wheel Mounting Nut  
Tightening Torque:  
29~36 lb-ft (40~50 Nm)**

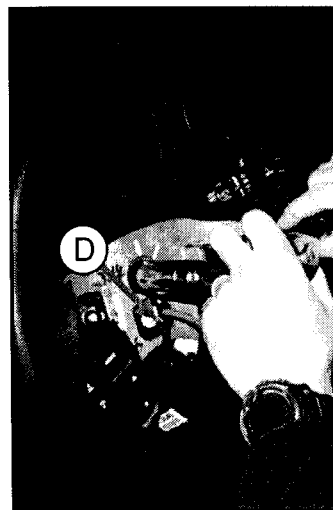

Rondo



Optima

**SUBJECT: RONDO & OPTIMA CLOCK SPRING ASSEMBLY REPLACEMENT (SC094)**

- 5. Remove the steering column upper and lower shrouds (E) by loosening the three (3) mounting screws.

**See below for detailed procedure to remove the Optima upper/lower shrouds.**

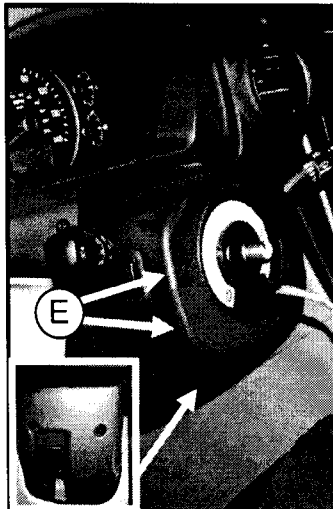

Rondo

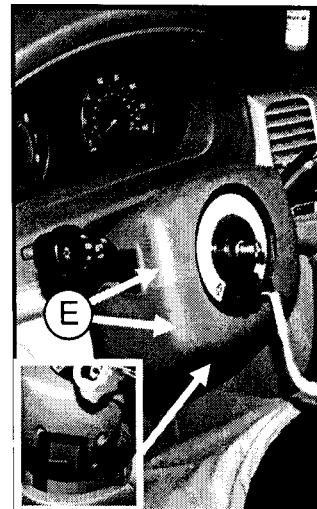

Optima

When removing the steering column upper and lower shrouds on the Optima, start by pressing inward on the lower left-hand side of the shroud as indicated in the photo, and pull downward, then pull the right-hand side down. Flip the top shroud upward out of the way.

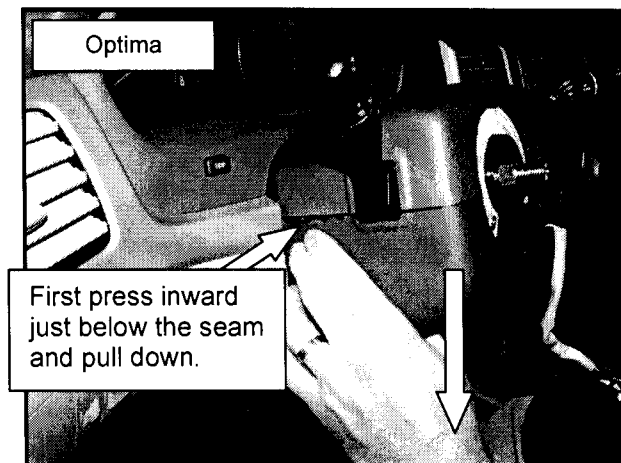

**SUBJECT: RONDO & OPTIMA CLOCK SPRING ASSEMBLY REPLACEMENT (SC094)**

6. Disconnect the clock spring connectors (F), and then remove the clock spring assembly by unlocking the three (3) clock spring mounting hooks.

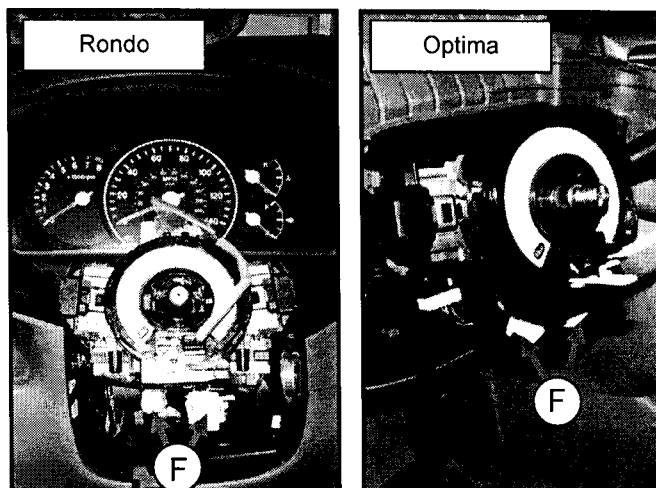
**\* NOTICE**

Do not remove white shipping tab from the new/replacement part until steering wheel has been re-installed.

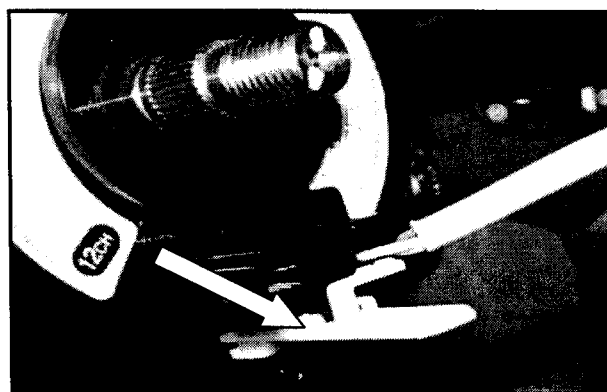

7. If no steering angle sensor is installed on the removed clock spring, install the new clock spring assembly (G) onto steering column by following step 9.

If steering angle sensor is installed on the removed clock spring, reuse the steering angle sensor by following the next step (8).

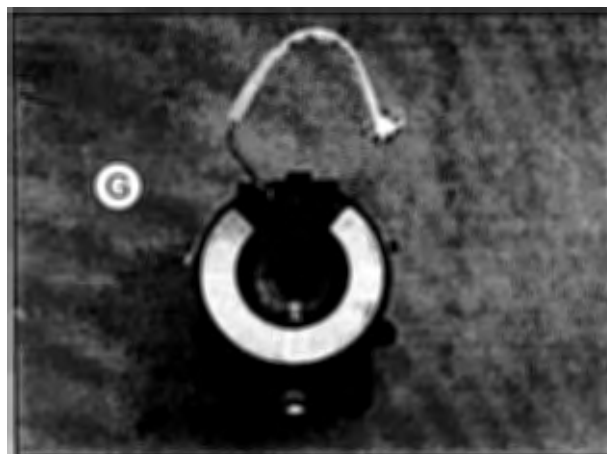
**\* NOTICE**

Only vehicles with ESC (Electronic Stability Control) are equipped with the steering angle sensor.

**SUBJECT: RONDO & OPTIMA CLOCK SPRING ASSEMBLY REPLACEMENT (SC094)**

8. Remove the steering angle sensor (H) from the removed clock spring assembly by releasing the tabs.

Install the steering angle sensor to the new clock spring assembly, seating the bottom tabs first and aligning the tabs to the proper slots.



9. Install the new clock spring assembly onto the steering column and connect the connectors under the clock spring.

**\* NOTICE**

**If the shipping tab is missing, then verify the standard position per the note on the clock spring part.**

Reinstall all removed parts in reverse order of removal. Make sure the steering wheel is straight & level after re-installation. Once the steering wheel has been installed, remove the shipping tab.

***Steering Wheel Mounting Nut  
Tightening Torque:  
29~36 lb-ft (40~50 Nm)***

Check for Diagnostic Trouble Codes using the GDS and erase any DTCs that are present.

Confirm proper functionality of steering wheel controls and switches. Reset customer's audio presets.

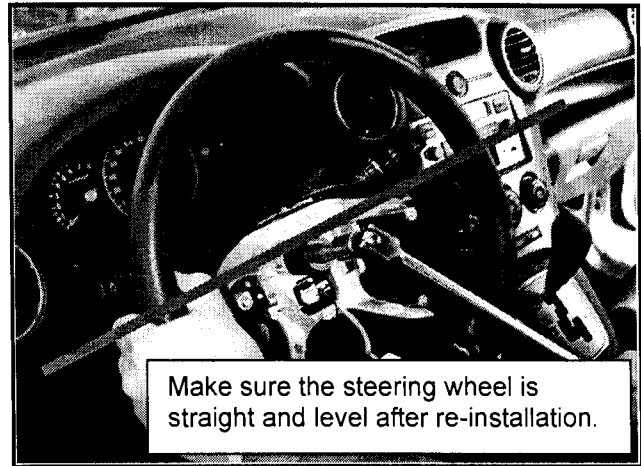

**SUBJECT: RONDO & OPTIMA CLOCK SPRING ASSEMBLY REPLACEMENT (SC094)**

## AFFECTED VEHICLE PRODUCTION RANGE:

Model	Production Date Range
Rondo (UN)	September 13, 2006 to March 21, 2008
Optima (MG)	September 29, 2005 to January 29, 2008

## REQUIRED PART:

Model	Part Name	Part Number	Figure
Rondo (UN)	Clock Spring Assembly	93490 1D500QQK	
Optima (MG)		93490 2G500QQK	

## WARRANTY CLAIM INFORMATION:

Claim Type	Causal P/N	Qty.	N Code	C Code	Repair Description	Labor Op Code	Op Time	Replacement P/N	Qty.
R	93490 1D500	0	N69	C15	(SC094) Rondo (UN) Clock Spring Assembly Replacement	111127R1	0.5 M/H	93490 1D500QQK	1
	93490 2G500				(SC094) Optima (MG) Clock Spring Assembly Replacement	111127R0	0.5 M/H	93490 2G500QQK	1

**\* NOTICE**

To assure complete customer satisfaction, always remember to refer to WebDCS Warranty Coverage (validation) Inquiry Screen (Service>Warranty Coverage>Warranty Coverage Inquiry) for a list of any additional campaigns that may need to be performed on the vehicle before returning it to the customer.