

December 2012

SAFETY DEFECT / NONCOMPLIANCE NOTICE

PREVOST SAFETY RECALL CAMPAIGN SR12-47 "Automatic Fire Suppression System (AFSS) Extinguisher Cylinder Relocation"

Dear customer,

Prevost Car US Inc. has identified you as the registered owner of the following vehicles involved in safety recall SR12-47 :

This notice is sent to you in accordance with the requirements of the National Traffic and Motor Vehicle Safety Act and 49 CFR Part 573.

Prevost Car US Inc. has decided that a defect which relates to motor vehicle safety exists in certain 2011 – 2012 X3-45 coaches (see table below).

Model	VIN
X3-45 coach Model Year : 2011-2012	 <p>Vehicles equipped with AFSS - <i>extinguisher cylinder in engine compartment only.</i></p> <p>2PCG33499<u>B</u>C72<u>9965</u>, 2PCG33491<u>B</u>C72<u>9992</u> From 2PCG33499<u>B</u>C72<u>5002</u> up to 2PCG33490<u>B</u>C73<u>5086</u> incl. And From 2PCG33490<u>C</u>C73<u>5087</u> up to 2PCG33491<u>C</u>C73<u>5132</u> incl</p>
<p>This Safety Recall does not necessarily apply to all the above-mentioned vehicles, some vehicles may have been modified before delivery. The owners of the vehicles affected by this recall will be advised by a letter indicating the Vehicle Identification Number (VIN) of each vehicle concerned.</p>	

DEFECT DESCRIPTION

On the vehicles involved in this recall, there is a possibility that the AFSS fire extinguisher cylinder’s nitrogen discharge pressure is lost.

FAILURE CONSEQUENCE

In case of fire, AFSS system would not work as planned.

CORRECTIVE ACTIONS

Prevost Car US Inc. has voluntarily decided all suspected vehicles shall have their extinguisher cylinder relocated in the third luggage compartment, street side, free of charge. You must refer to safety recall SR12-47 for the complete procedure.

REPORTING REQUIREMENT

In order to verify and document the corrective action taken on your vehicle(s) pursuant to the requirements of the Federal Motor Vehicle Safety Regulations, we are enclosing a Safety Recall Certification sheet. When the vehicle(s) is (are) repaired, this (these) sheet(s) must be completed and returned to:

*Prevost
Warranty Department
850, chemin Olivier
Saint-Nicolas QC
G7A 2N1 Canada*

If you are a Lessor of vehicles subject to this notice, federal regulation requires that you forward a copy of this notice to the lessee within ten days.

If you no longer own the vehicles(s) listed on the first page, please help us update our records by completing the following section and returning it at the address above or at *prevost.onlinewarranty@volvo.com* with 'Change of Ownership' as Subject.

Vehicle Identification Number (VIN) : _____

New owner name and address : _____

Phone and fax# : _____

LABOR & PARTS REIMBURSEMENT:

Prevost Car US (Inc) will reimburse the parts and labor as described in SR12-47.

Federal laws require that you be informed of your right to notify the *Department of Transportation* if you are unable to have the defect remedied without charge. The address for this purpose is:

National Highway Traffic Safety Administration
1200 New Jersey Avenue SE
Washington, DC 20590
USA
Auto Safety Hotline: 1-888-327-4236
Teletypewriter (TTY): 1-800-424-9153
<http://www.safercar.gov>

If any assistance is required, please contact Prevost Car US (Inc) service department.

We regret any inconvenience this may cause to your operation, but hope you will appreciate our sincere efforts to demonstrate Prevost's commitment to provide our customers with the best possible product.

Truly yours,

A handwritten signature in black ink, appearing to read 'D Gagnon', with a stylized flourish at the end.

Dominique Gagnon
Technical Publications Supervisor



PREVOST

SAFETY RECALL

SR12-47

DATE : DECEMBER 2012	SECTION : 23-ACCESSORIES
SUBJECT : AUTOMATIC FIRE SUPPRESSION SYSTEM (AFSS) EXTINGUISHER CYLINDER RELOCATION	

APPLICATION

Model	VIN	
X3-45 coach Model Year : 2011-2012	Vehicles equipped with AFSS - <i>extinguisher cylinder in engine compartment only.</i> 2PCG33499 <u>BC729965</u> , 2PCG33491 <u>BC729992</u> From 2PCG33499 <u>BC725002</u> up to 2PCG33490 <u>BC735086</u> incl. And From 2PCG33490 <u>CC735087</u> up to 2PCG33491 <u>CC735132</u> incl.	
This Safety Recall does not necessarily apply to all the above-mentioned vehicles, some vehicles may have been modified before delivery. The owners of the vehicles affected by this recall will be advised by a letter indicating the Vehicle Identification Number (VIN) of each vehicle concerned.		

DESCRIPTION

On the vehicles involved in this recall, there is a possibility that the AFSS fire extinguisher cylinder's nitrogen discharge pressure is lost. In case of fire, AFSS system would not work as planned.

Extinguisher cylinder must be relocated in the third baggage compartment street side.





Please read the complete bulletin before performing any work and refer to the drawings provided in the kit and at the end of this bulletin.

IMPORTANT NOTE

Because the fuel tank must be drained, make sure fuel tank is near empty before performing this bulletin.

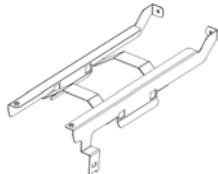
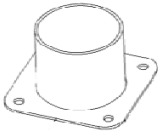
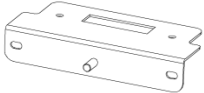
MATERIAL

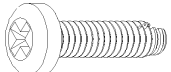
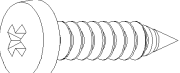
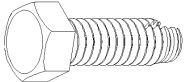
Order Kit #406564, composed of the following parts:

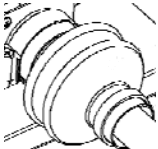
Part No.	Image	Description	Drawing reference	Qty
374643		Slit hose – 7/8" x 8" lg	6	2
374667		Slit hose - 8" lg	9	1
374668		Slit hose - 21 1/2" lg	11	1
406516		Extinguisher Cylinder support	201	1
406518		Bulkhead flange	5	2
406562		Extinguisher Cylinder structural support road side	401	1
406563		Extinguisher Cylinder structural support curb side	400	1
406517P		Hose (290 in. lg)	1	1
500623		Screw, thread cutting, 10-24 x 3/4	315	1
500957		Tap screw BDG PH N500 #10x3/4	16	9
502848		Screw, thread cutting, 1/4-20 x 3/4	402	4
504013		Tie mount	2	6
504016		Cable tie	3	20
504022		Hose clamp 3/4"-1 3/4"	8	1
504068		Rubber grommet .500x.750x.062x.312x1.062"	-	2
504384		Cuff- end Bellows	7	1
509491		Cable tie, heavy duty	200	2

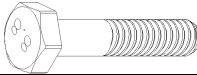
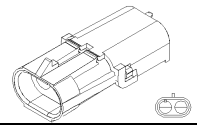
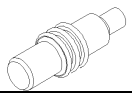
5001744		Cap screw M6x1.0 x 16 GR8.8	202	4
5001833		Spring washer SS	203	8
561566		Weather pack pin housing, 2C	-	1
561783		Weather Pack Seal plug	-	2
068542		Patch cable	-	1
D400451		Installation drawing	-	1
D400463		Extinguisher cylinder installation drawing (in service)	-	1

Other material needed *not included in this kit*

680532		Sikaflex 221 cartridge	10	1
--------	--	------------------------	----	---

NOTE
Material can be obtained through regular channels.

PROCEDURE

 **DANGER**

Park vehicle safely, apply parking brake, stop engine and set battery master switch(es) to the OFF position prior to working on the vehicle.

 **WARNING**

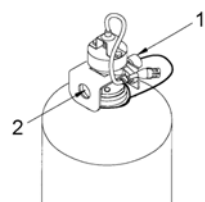

1. The anti-recoil cap should be installed on the extinguisher valve outlet port at all times except when the extinguisher is connected to the distribution piping.
2. Prior to installing the extinguisher in its new location, the pressure gauge should be inspected to ensure that the needle is situated in the green zone. If it is not in the green zone, the cylinder should be replaced.

 **WARNING**

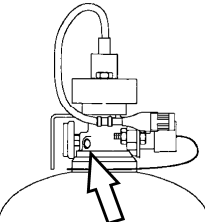

Inspect the fusible pressure relief plug.

If it is flush, the cylinder is good.

If it is protruding, replace the cylinder and return the defective cylinder to Prevost.



FLUSH



PROTUDING

Procedure requires removing the AFSS extinguisher cylinder from the engine compartment and relocating it in the third baggage compartment street side. Some drilling is required for proper routing of hose and cables.

NOTE

AFSS hose routing should be performed from front to rear of vehicle.

The hose end at the engine compartment is fitted with a straight fitting which allows easy fishing and routing, as opposed to an elbow at the other end.

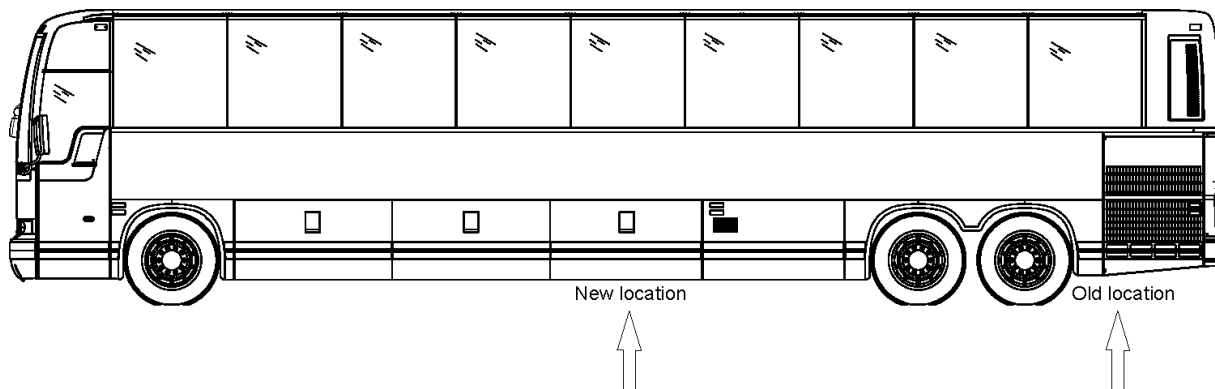

1. To access AFSS extinguisher cylinder, lift hinged rear fender, remove aft wheel and aft wheel arch liner.

Disconnect and discard hose linking cylinder to nozzle distribution piping.

Disconnect electrical connector.

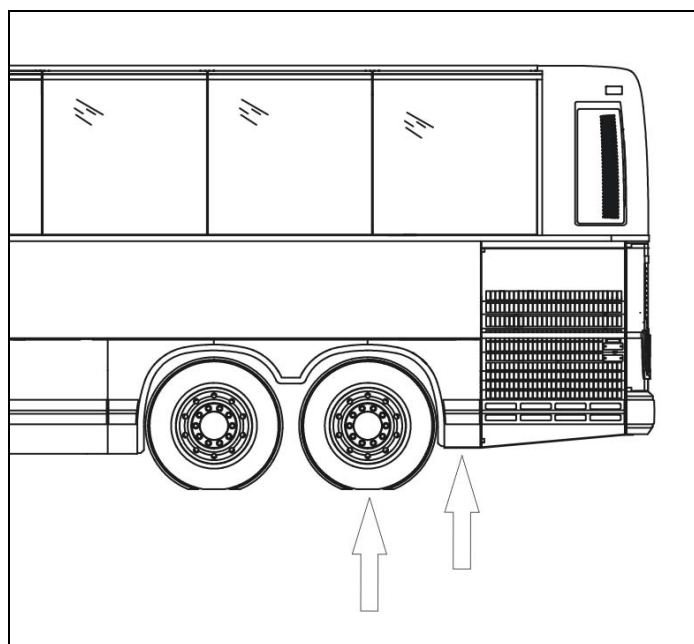

2. Disassemble cylinder from bracket.
Install anti-recoil cap.

If bracket does not support any other element or is no longer required, discard.

Depending on vehicle, existing electrical connector will either be used to connect a patch cable or will be protected with cap and plugs.

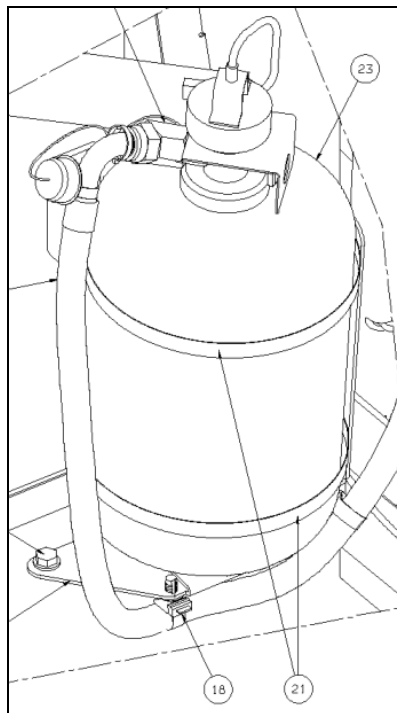

3. Drilling through partitions is required at arrow locations below. Refer to drawing D400451P1 for hose routing.

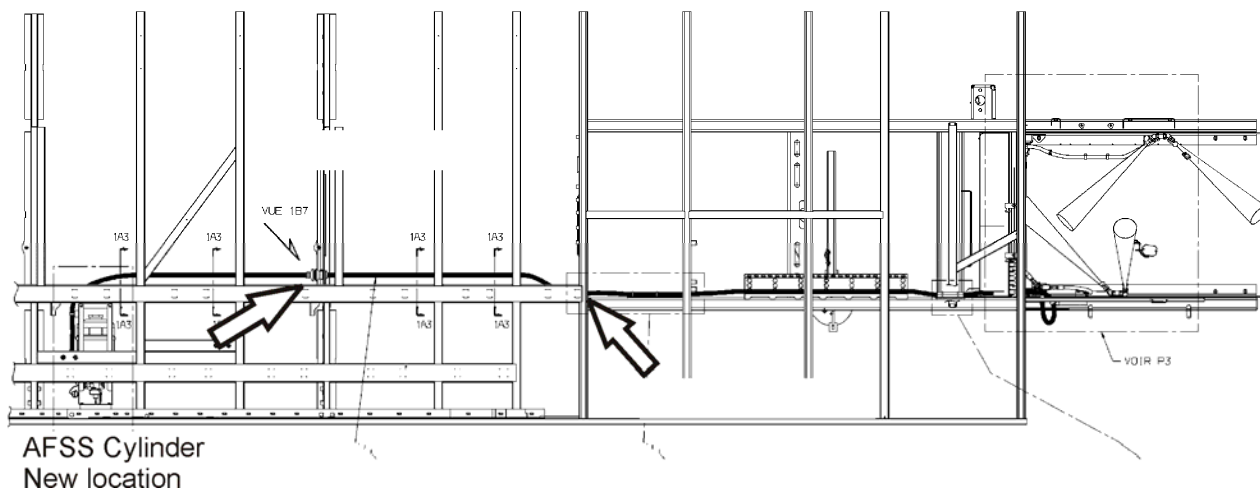

4. Drain the fuel tank into a suitable container (this operation may take hours depending on the quantity of fuel present).

To drain the fuel tank, it is recommended to siphon fuel through the connection panel on top of fuel tank or the filler tube.

We do not recommend removing the plug at the bottom of the tank. Doing this may increase future risks of fuel seepage.

5. Disconnect fuel supply and return lines, electrical harness and vent tubes, etc. from the fuel tank connection panel.
6. Place six jack stands under the fuel tank support at arrow locations.
7. Dismount tank support from vehicle.
8. Lift the vehicle.

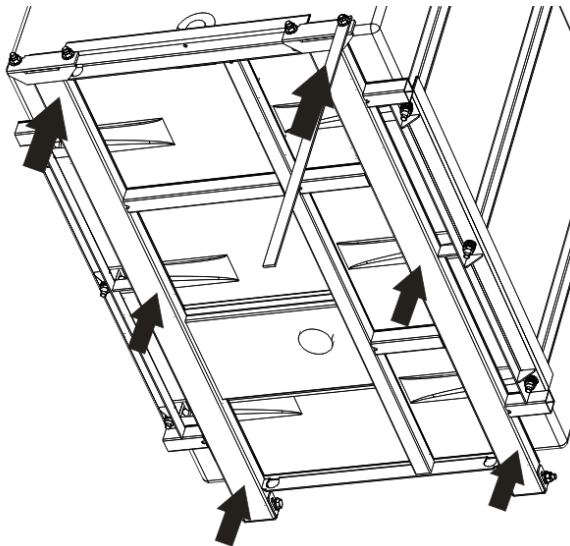

9. Inside the third baggage compartment, on the aft wall, center road side, position bulkhead flange #406518 as follows:

5 inches from RH top beam

3 inches from ceiling.

Drill using bulkhead flange as a template.

Drill 1 3/4 in. hole in the center and 1/8 inch for the 4 flange holes..

Install with #500957 tap screws.

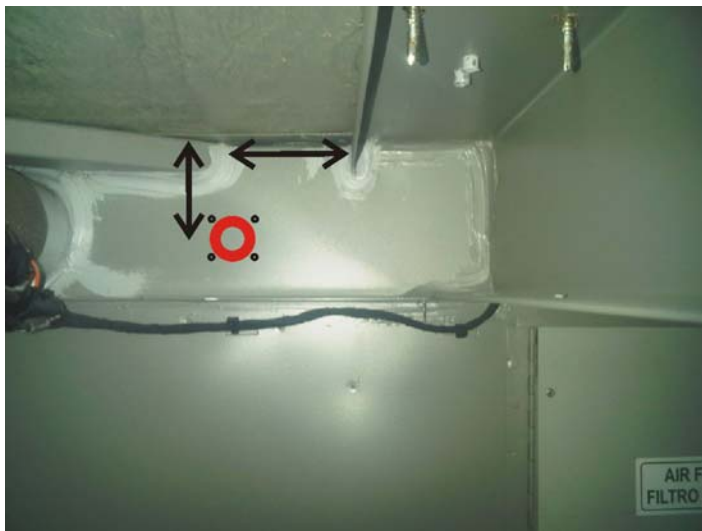

10. Install Extinguisher Cylinder structural support road side and curb side #406562 & #406563. Refer to drawing D400463 for positioning.

NOTE

There are copper tubes above this area. Take care not to drill through the complete thickness of the floor.



11. Connect hose to extinguisher.
12. Attach hose using tie mount #504013, thread cutting screw #500957 and cable tie #504016.

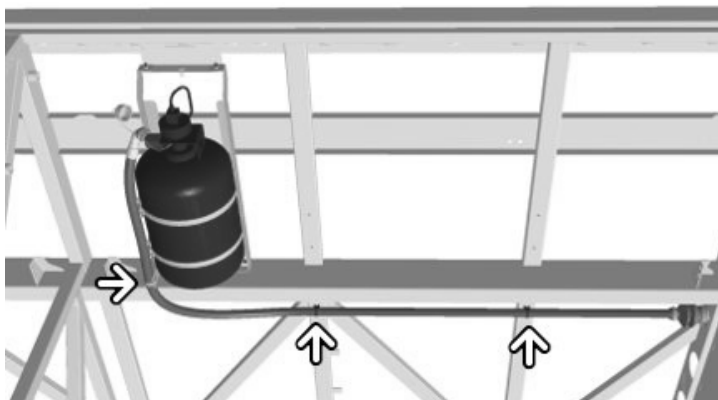

13. Routing in the fuel tank area.
Attach hose using tie mount #504013, #500957 thread cutting screw and cable tie #504016

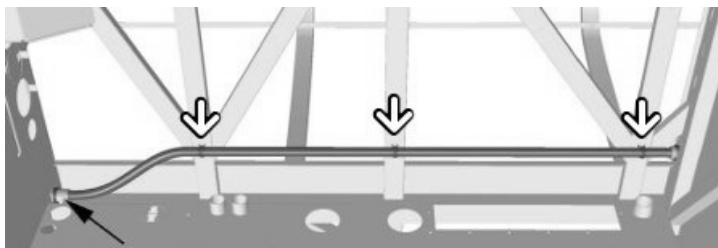

14. On the rear wall of the fuel tank area, drill using #406518 bulkhead flange as a template.
Drill 1 3/4 in. hole in the center and use 1/8 inch drill bit for small plate holes.
Install with #500957 tap screws.
Refer to view 1A4 on drawing D400451P1 for sealing and hose protection measures



15. Routing in the rear axle well.

Proper access requires removing an air tank

Protect with slit hose #374668 and attach using cable tie #504016.

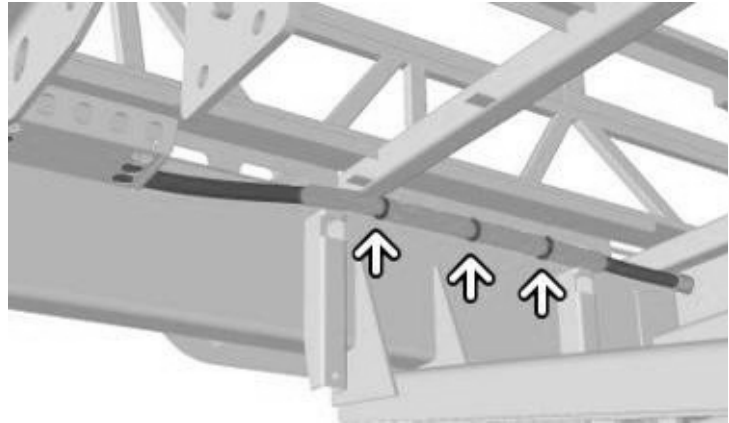

16. In the cable and hose tray, use a fishing technique to pull hose up to engine compartment

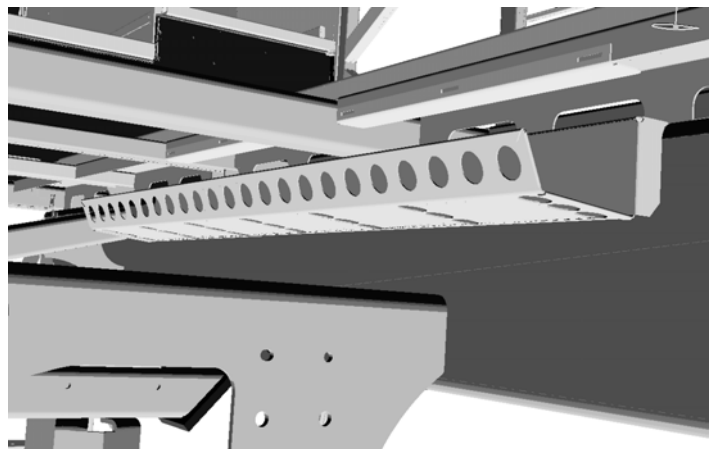

17. Routing from rear axle well up to engine bay follows layout in drawing D400451.

Protect with slit hose #374667 and attach using cable tie #504016.

Attach hose using:

- tie mount #504013,
- thread cutting screw #500623
- cable tie #504016.

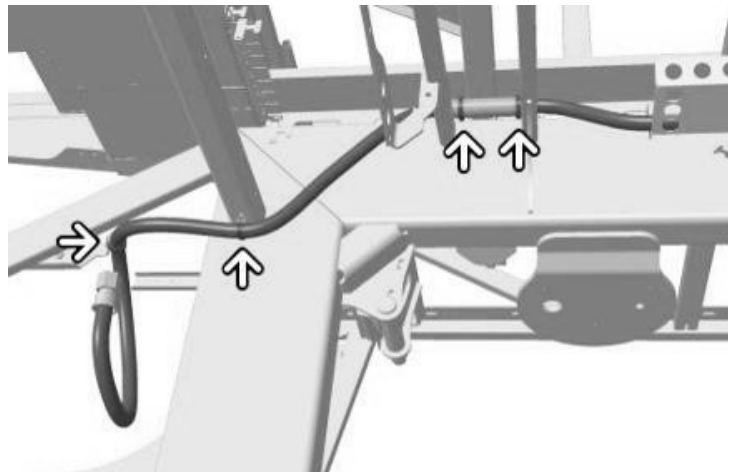

18. In engine compartment, use cable ties to secure hose as required.



19. Connect hose to extinguisher nozzle distribution in the engine bay as specified on drawing D400451P3&P4.

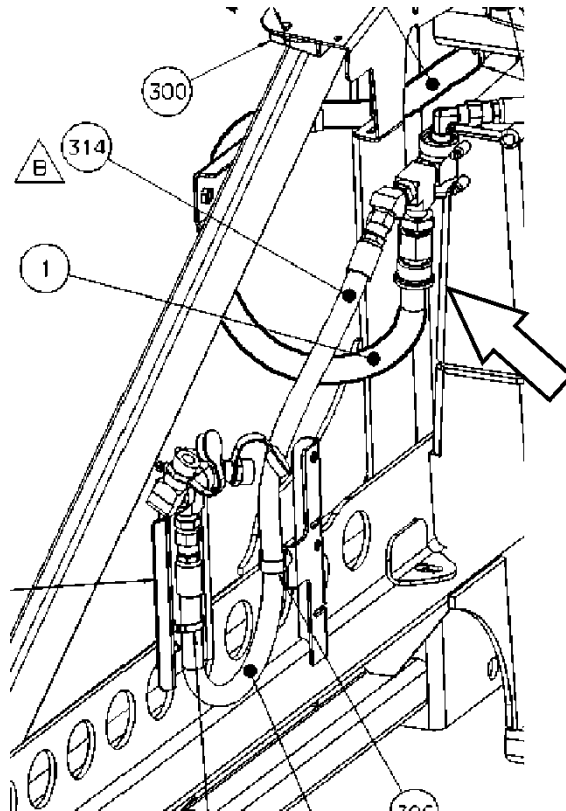

1. Returning to third baggage compartment. Refer to view 1B7 on drawing D400451P1 for hose protection and baggage compartment sealing.

Apply a liberal amount of #680532 Sikaflex over screws and around flange.

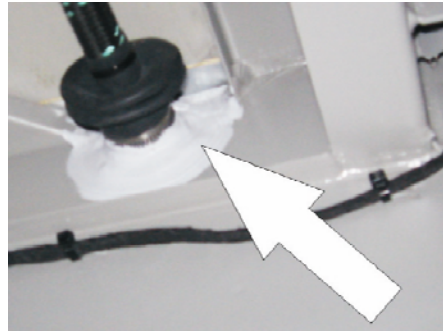
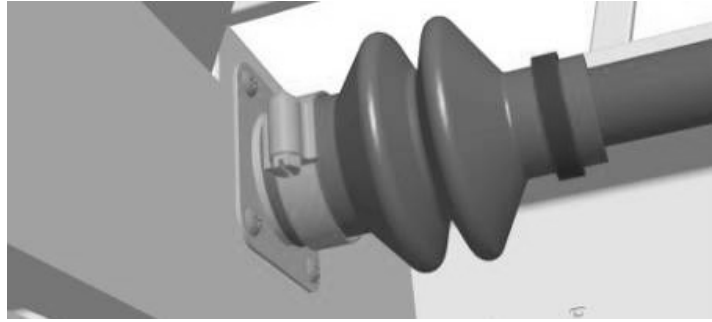

Electrical connection

2. Depending on vehicles in the 3rd baggage compartment, you may find a wiring provision labeled "L282A" for connection of the AFSS cylinder. It will be tied in with the baggage compartment harness



3. To conform to Kidde Standards, the 3/8" ring terminal, part of "L282A" wiring provision must be sealed with solder and heat shrink tube.

Remove blue plastic tube. Apply a sufficient amount of solder to seal closed the crimped connection.

The barrel portion of the ring terminal should be covered with adhesive lined heat shrink seal 2 times the length of the barrel.

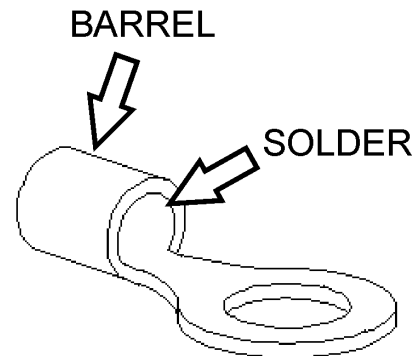

4. Plug connector to the cylinder.
5. Connect ring terminal to ground stud provided on the road side cylinder bracket
6. Returning to the engine compartment, install 561566 pin housing and 561783 seal plugs on the original connector of the AFSS cylinder to protect from moisture and dust.



20. If no provision is available, route #068542 patch cable from the original cylinder location in the engine compartment up to the third baggage compartment. Routing of the patch cable follows usual harness routing in vehicle as shown in view below.

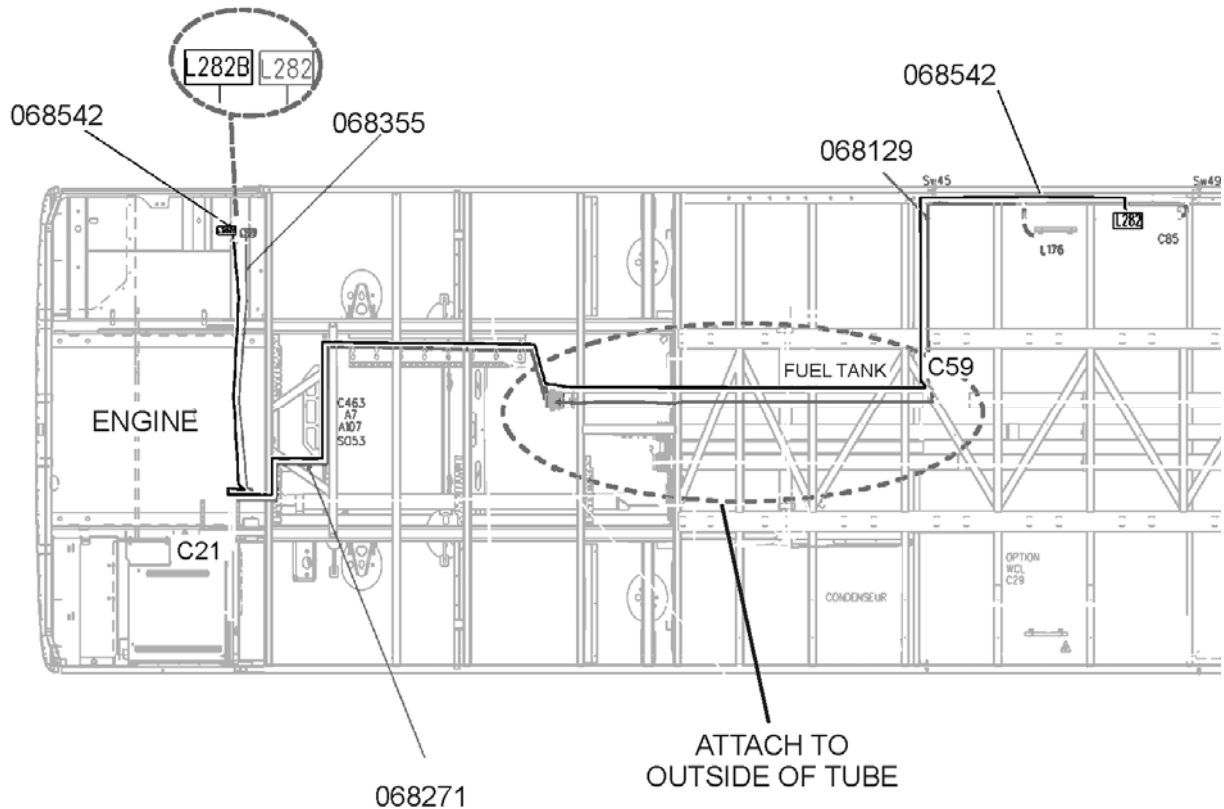

21. Connect #068542 patch cable to original extinguisher cylinder cable (#068355) at original location in the engine compartment.
22. Route back towards rear junction box following cable #068355.
23. Locate connector **C21** on rear junction box and cable #068271. Continue routing of patch cable following cable #068271 over the rear axle up to white ABS tubes.
24. Attach cable to the exterior of the tube over fuel tank and up to third baggage compartment. Drill both partitions as required and add rubber grommets #504068 to protect cable.
25. In the third baggage compartment, locate connector **C59** and follow cable #068129 up to relocated cylinder location. Connect to the AFSS cylinder and connect to ground stud provided on the road side cylinder bracket.

26. Re-install Fuel tank.



REFERENCE DRAWINGS

For detailed consultation; please refer to the paper copies provided in kit 406564.

D400451P1

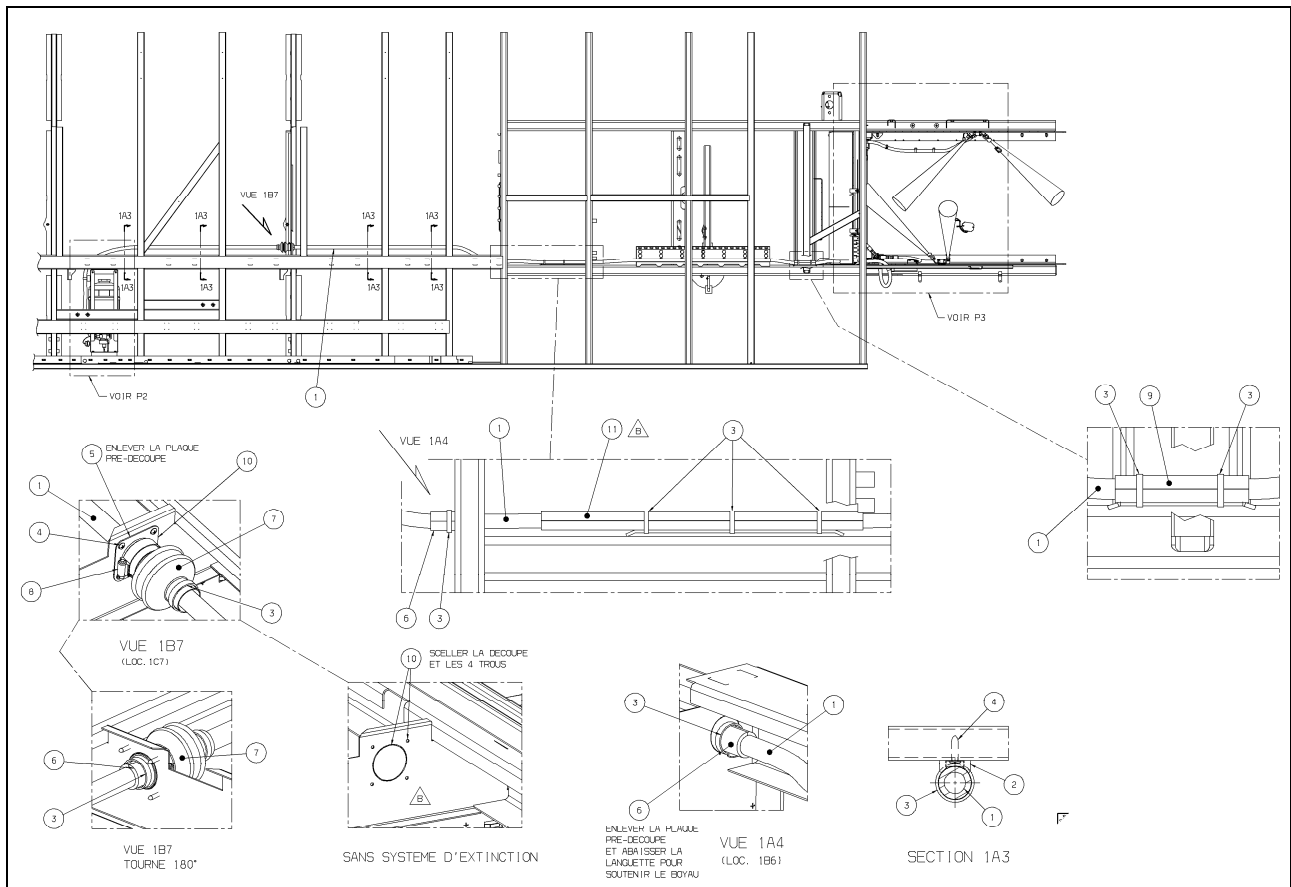

D400451P3

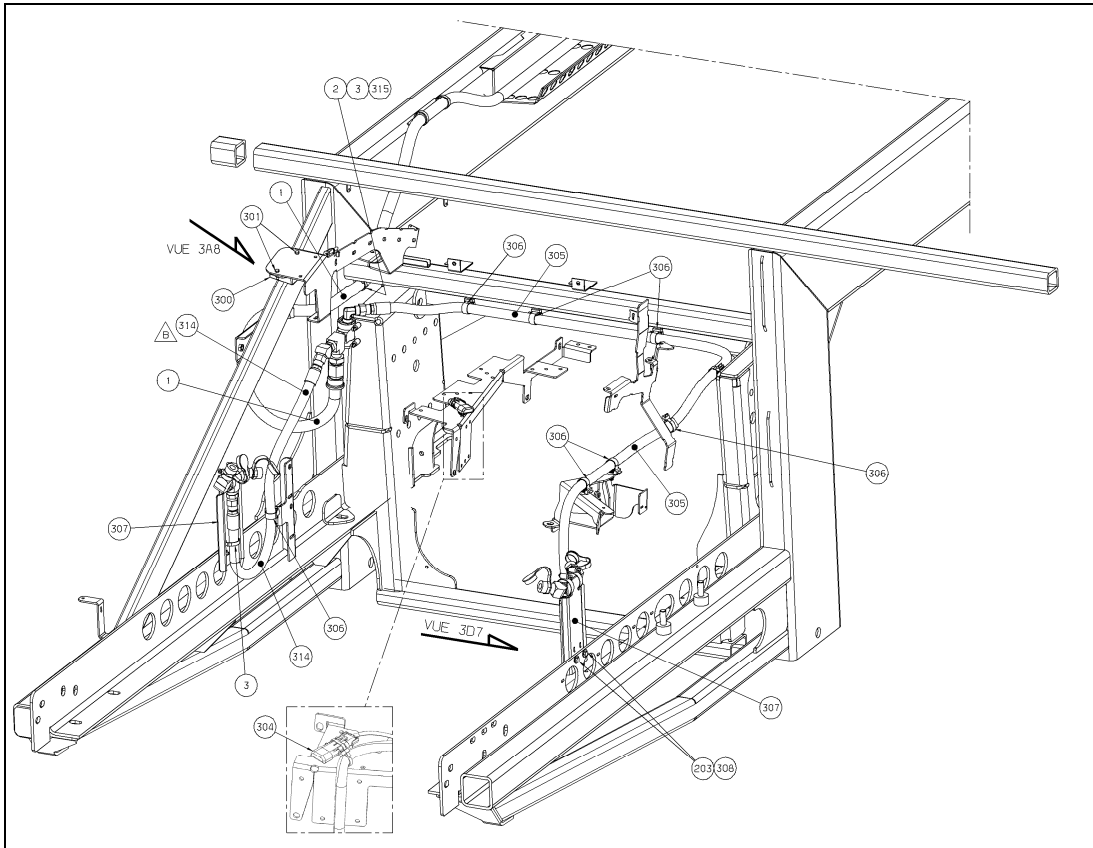

D400451P4

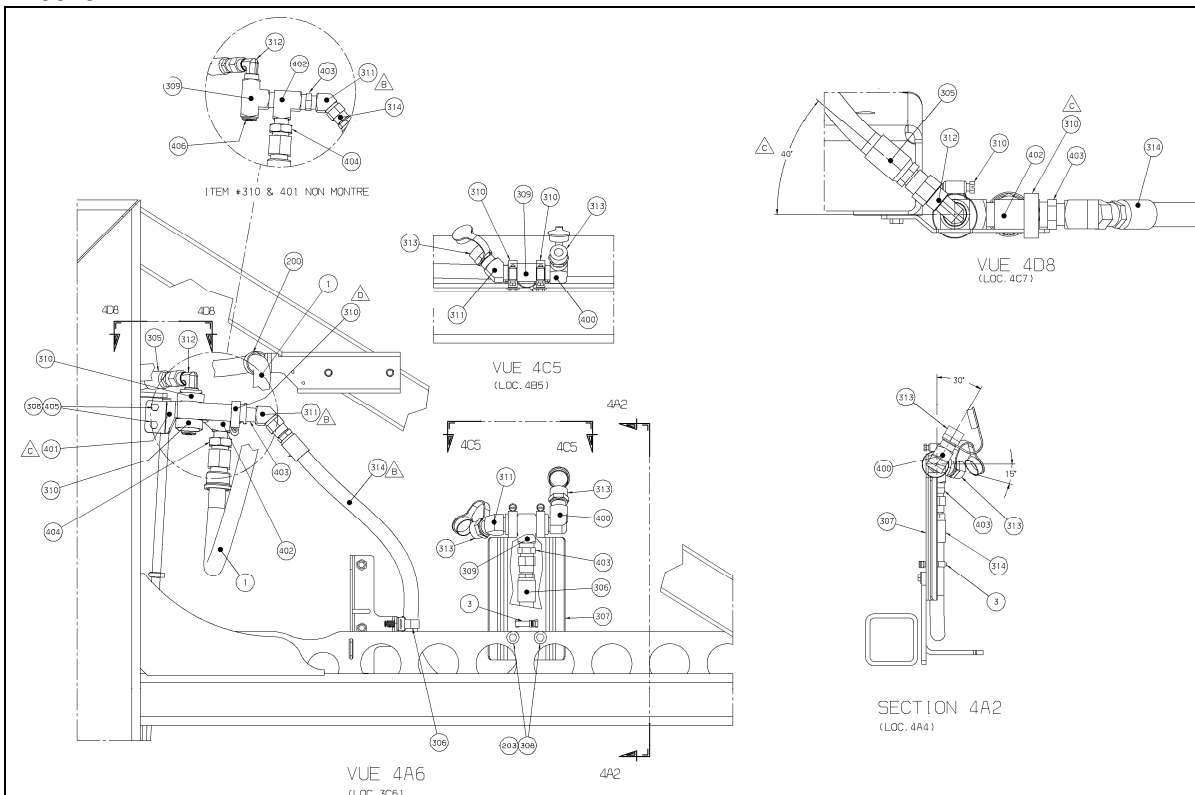

D400463

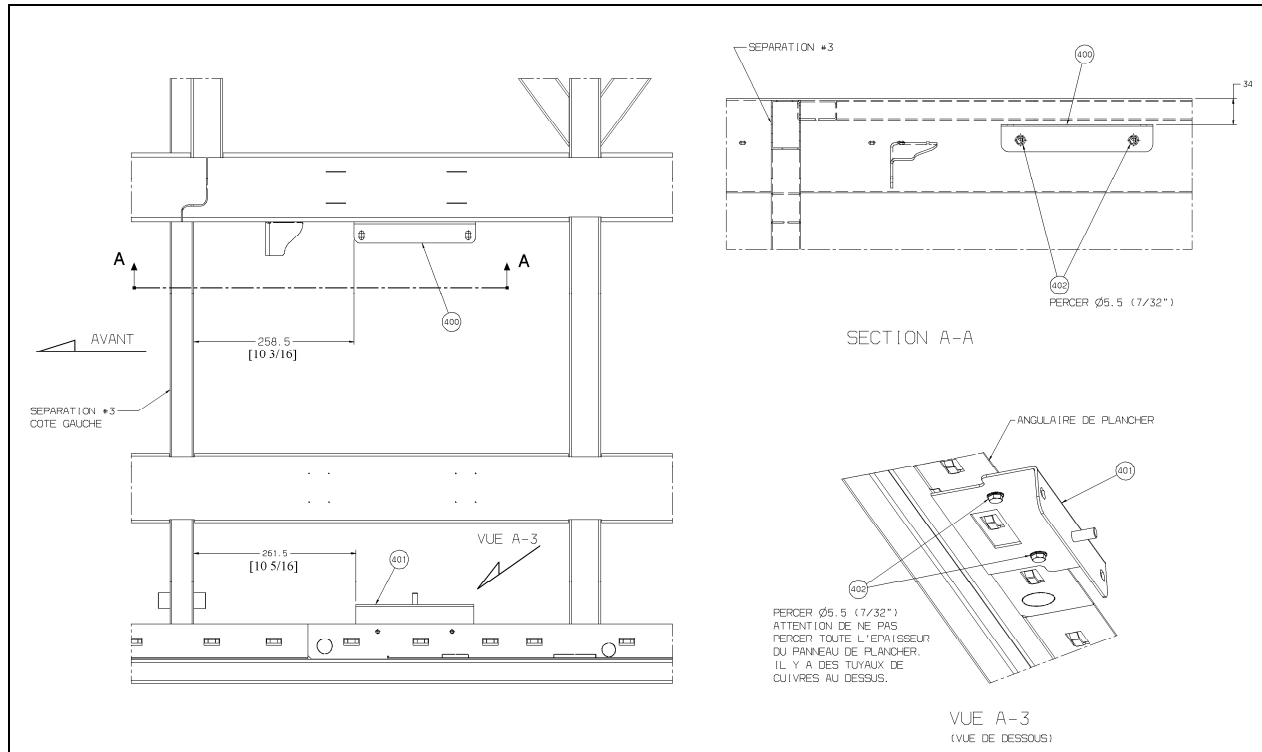

PARTS DISPOSITION

- Return to Prevost with A.F.A. for full reimbursement.
- Discard according to applicable environmental regulations (Municipal/State[Prov.]/ Federal)

WARRANTY

This modification is covered by Prevost's normal warranty. We will reimburse you the parts and ten hours (10.0h) of labor upon receipt of a completed A.F.A. form on which you must specify as per "Safety Recall 12-47". **You also have to fill the "Safety Recall Certification Sheet" provided with this bulletin and return it with your A.F.A. form to be reimbursed.**

OTHER

VBC Bulletin	N/A
Fail Code	23.08
Defect Code	09
System Condition	R
Causal Part	901125

Access all our Service Bulletins on
<http://prevostparts.volvo.com/technicalpublicatios/en/pub.asp>
Or scan the QR-Code with your smart phone.





PREVOST

**Safety Recall
Certification Sheet
(Ref: SR12-47)**

ENREGISTRÉ - REGISTERED
ISO 9001 & ISO 14001



SERIAL NUMBER: _____

PERFORMED BY		OWNER/OPERATOR	
We hereby certify that Safety Recall Instructions with regard to Safety Recall #12-47 have been performed.			
Name: _____		Name: _____	
Addr: _____		Addr: _____	
Phone: _____		Phone: _____	
Fax: _____		Fax: _____	
Signature :	_____	Signature :	_____
Date:	_____	Date:	_____

If the information mentioned above is incorrect or you are not the owner of this vehicle anymore, please fill this section and return to sender.

NEW OWNER: _____

BUSINESS: _____

ADDRESS (including County): _____

TELEPHONE: _____ **FAX:** _____

Please return this completed document with your A.F.A. form