

January 2013

SAFETY DEFECT / NONCOMPLIANCE NOTICE

PREVOST SAFETY RECALL CAMPAIGN SR12-69 "Wheelchair Lift Cylinders and Maintenance Safety Pins"

Dear customer,

Prevost Car US Inc. has identified you as the registered owner of the following vehicles involved in safety recall SR12-69 :

This notice is sent to you in accordance with the requirements of the National Traffic and Motor Vehicle Safety Act and 49 CFR Part 573.

Prevost Car US Inc. has decided that a defect which relates to motor vehicle safety exists in certain 2009 to 2013 Volvo 9700 coaches (see table below).

VIN	
2009 up to 2013 9700 equipped with Wheelchair Lift	From 3CET2M621 <u>95133518</u> up to 3CET2S225 <u>D5157596</u> incl.

DEFECT DESCRIPTION

The vehicles involved in this recall may have missing maintenance safety pins on the sides of their wheelchair lift. There is also a possibility that the wheelchair lift cylinders may not be of proper length. If this is the case, the maintenance safety pins may not be properly used.

FAILURE CONSEQUENCE

Risk of injuries during wheelchair lift unit maintenance or repair, as pins' role is to block in place the wheelchair lift unit.

CORRECTIVE ACTIONS

Prevost Car US Inc. has voluntarily decided that for all vehicles involved, shall have their wheelchair lift inspected and corrected free of charge. You must refer to safety recall SR12-69 for the complete procedure.

REPORTING REQUIREMENT

In order to verify and document the corrective action taken on your vehicle(s) pursuant to the requirements of the Federal Motor Vehicle Safety Regulations, we are enclosing a Safety Recall Certification sheet. When the vehicle(s) is (are) repaired, this (these) sheet(s) must be completed and returned to:

*Prevost
Warranty Department
850, chemin Olivier
Saint-Nicolas QC
G7A 2N1 Canada*

If you are a Lessor of vehicles subject to this notice, federal regulation requires that you forward a copy of this notice to the lessee within ten days.

If you no longer own the vehicles(s) listed on the first page, please help us update our records by completing the following section and returning it at the address above or at prevost.onlinewarranty@volvo.com with 'Change of Ownership' as Subject.

Vehicle Identification Number (VIN) :

New owner name and address :

Phone and fax# :

LABOR & PARTS REIMBURSEMENT:

Prevost Car US (Inc) will reimburse the parts and labor as described in SR12-69.

Federal laws require that you be informed of your right to notify the *Department of Transportation* if you are unable to have the defect remedied without charge. The address for this purpose is:

National Highway Traffic Safety Administration
1200 New Jersey Avenue SE
Washington, DC 20590
USA
Auto Safety Hotline: 1-888-327-4236
Teletypewriter (TTY): 1-800-424-9153
<http://www.safercar.gov>

If any assistance is required, please contact Prevost Car US (Inc) service department.

We regret any inconvenience this may cause to your operation, but hope you will appreciate our sincere efforts to demonstrate Prevost's commitment to provide our customers with the best possible product.

Truly yours,



Dominique Gagnon
Technical Publications Supervisor

Date	Expiration	Group	No.	Page
12.2012	n/a		01	1(6)

**WHEELCHAIR LIFT: SERIAL NUMBER AND MAINTENANCE
SAFETY PIN INSPECTION
9700 (B13R)**

MODEL YEAR(S) AND VEHICLE SERIAL NUMBERS (VIN) INVOLVED

VIN	
2009 up to 2013 9700 equipped with Wheelchair Lift	From 3CET2M621 <u>95133518</u> up to 3CET2S225 <u>D5157596</u> incl.

DESCRIPTION

On the vehicles affected by this bulletin, the wheelchair lift unit has to be inspected at the next service occasion as the maintenance safety pins may be missing and/or the wheelchair lift cylinders may not be the proper length, preventing the use of maintenance safety pins.

MATERIAL

NOTE: the material in the list below might not be needed. Please proceed to your vehicle inspection first.

Part No	Part description	Quantity per vehicle
864977	Pin, Quick Release, 1/4 dia x 3" Lg	2
864978	Chain, Bead Lanyard	2
865021	P-Clamp, 3/16"	2
865022	Screw, PHP,10-32x3/8, stainless steel	2
N8892943	Screw, PHP,10-32x0.313, stainless steel	2
---	Label (unique per vehicle serial number)	3

Date	Expiration	Group	No.	Page
12.2012	n/a		01	2(6)

PROCEDURE



DANGER

Park vehicle safely, apply parking brake, stop engine. In the battery box, set the battery cut-off switch to the OFF position prior to working on the vehicle.

Part I: Inspection of Wheelchair Lift Decals and Cylinders

- 1) Locate the wheelchair lift decals.

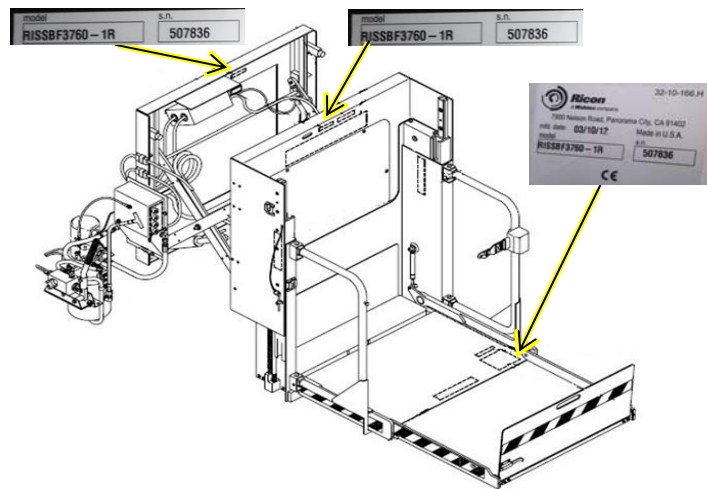

- 2) Serial number on the decals should end with '60-1R'.

If not, please replace them.

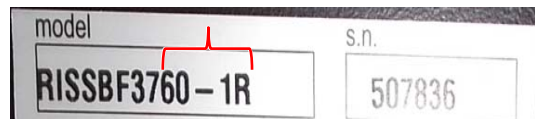

- 3) Check that both cylinders are marked with '29.5' **Note:** this marking could be on the "back side" of the cylinder, in which case an inspection mirror might be necessary.

If not, please contact your nearest Prevost Service Center or Service Manager to organize replacement of cylinders



Date	Expiration	Group	No.	Page
12.2012	n/a		01	3(6)

Part II: Inspection of the Maintenance Safety Pins and Chains

- 4) Open the Wheelchair lift door;
- 5) Make sure there are maintenance safety pins on each side of the wheelchair lift unit.



- 6) If maintenance safety pin or chain is missing, please install it.

At left side fix at the top with a screw 19718 and at the bottom with 3/8" long screw 865023 and 3/16" p-clamp 865021.

On the right side, fix together with the cable of the control pendant with a screw 19718 and the existing clamp, and at the bottom with 5/16" long screw N8892943 and 3/16" p-clamp 865021.



Date	Expiration	Group	No.	Page
12.2012	n/a		01	4(6)

- 7) Check the maintenance safety pin can be inserted easily.

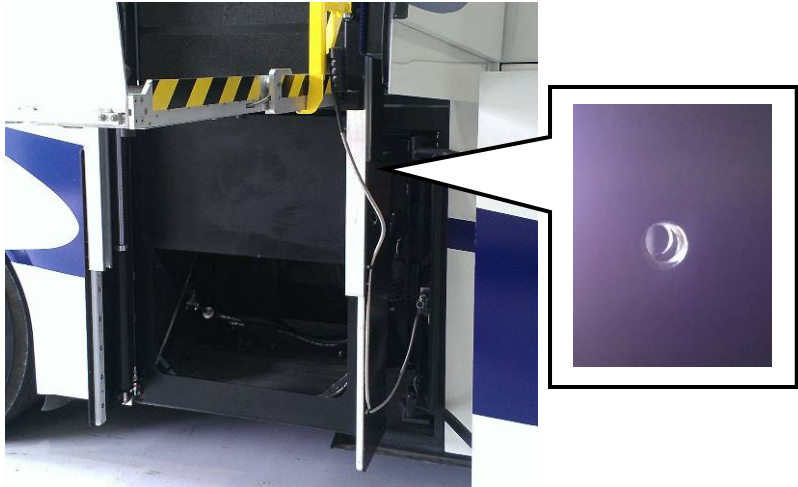

Part III: If holes are missing or do not align.

- 1) Lift the Platform frame up to get 43 +/- 0.3 inches between Platform frame and Intermediate frame.

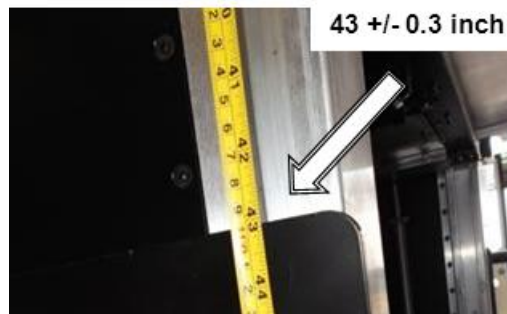
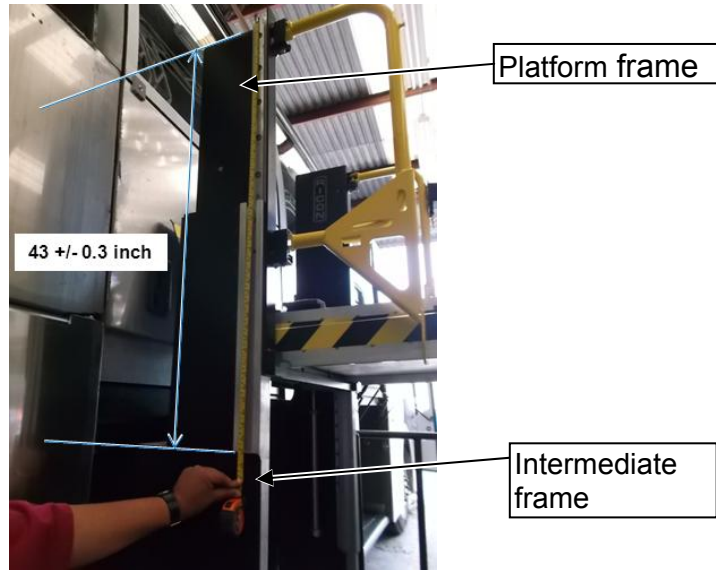

- 2) Check that holes of Intermediate frame and aluminum track of platform frame are aligned, if not, on the aluminum track make a hole of 5/16 in using the intermediate frame hole as guide.

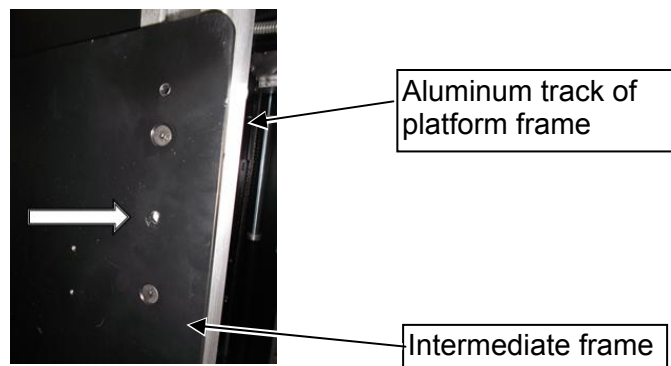

- 3) Check that new hole is free

Date	Expiration	Group	No.	Page
12.2012	n/a		01	6(6)

of burrs.

Note! New hole always will be on the top of old one.



- 4) Check that maintenance safety pin goes through the new hole easily.

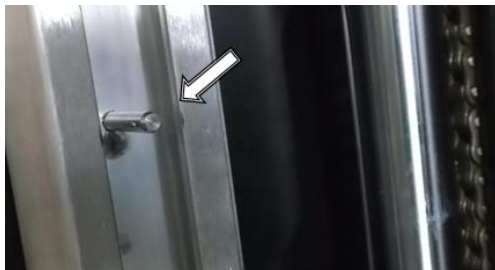

- 5) Repeat steps one through 4 for the remaining side.

WARRANTY

This modification is covered by Prevost's normal warranty. We will reimburse you the parts and one hour (1h) of labor for Inspection, 1.5 hours if rail drilling is required and an additional 6 hours for replacement of cylinders, if needed, upon receipt of a completed A.F.A. form on which you must specify as per "Safety Recall 12-69".

TELL US WHAT YOU THINK!

We are interested in hearing your comments or suggestions regarding this bulletin. Please e-mail them to: TechnicalPublications@volvo.com

OTHER

VBC Campaign	C6100
Fail Code	25-00
Defect Code	09
System Condition	R
Causal Part	864979

Prevost engages in a continuous program of testing and evaluating to provide the best possible product. Volvo Bus, however, is not committed to, or liable for updating existing products.



PREVOST

**Safety Recall
Certification Sheet
(Ref: SR12-69)**

ENREGISTRÉ - REGISTERED
ISO 9001 & ISO 14001



SERIAL NUMBER: _____

PERFORMED BY		OWNER/OPERATOR	
We hereby certify that Safety Recall Instructions with regard to Safety Recall #12-69 have been performed.			
Name: _____		Name: _____	
Addr: _____		Addr: _____	
Phone: _____		Phone: _____	
Fax: _____		Fax: _____	
Signature :	_____	Signature :	_____
Date:	_____	Date:	_____

If the information mentioned above is incorrect or you are not the owner of this vehicle anymore, please fill this section and return to sender.

NEW OWNER: _____

BUSINESS: _____

ADDRESS (including County): _____

TELEPHONE: _____ **FAX:** _____

Please return this completed document with your A.F.A. form