



BLUE BIRD

R12VH

August 23, 2012

Dear Blue Bird Owner:

This notice is sent to you in accordance with the requirements of the National Traffic and Motor Vehicle Safety Act. Blue Bird Corporation has decided that certain 2013 model year All American, Vision model school and non-school buses manufactured from April 30, 2012 through June 23, 2012 fail to conform to the requirements of Federal Motor Vehicle Safety Standard No. 209 "Seat Belt Assemblies", S4.4 "Requirements for Performance".

On the subject buses, the driver's seat belt may have been inadvertently installed with buckles and latch plates (tongues) that are mismatched. The tongue on one style buckle may mate up to another style buckle receiver but the tongue may not be properly engaged in the buckle. Should this condition occur, the seat occupant may not be properly restrained and could be injured in a vehicle crash or sudden stop. Blue Bird is conducting a recall to correct this noncompliance.

Your Blue Bird bus(es) affected by this recall are identified by **body serial number(s)** on the enclosed reply sheets. If you no longer own the subject bus(es), please complete the appropriate section of the **yellow** reply sheet and return to Blue Bird in the enclosed pink postage prepaid envelope.

You may contact your Blue Bird dealer to arrange to have this recall performed. Or, if you prefer, you may perform this recall yourself or have a qualified repair facility convenient to you perform this recall. A qualified technician should perform this recall.

To receive parts, if required, to correct this condition, you must return the "R12VH Inspection and Parts Order Form" to Blue Bird in the pink, self addressed, postage prepaid envelope. Be sure to provide a valid shipping address as UPS does not deliver to P.O. Boxes.

Labor time to inspect for correct buckle and tongue combination is 0.1hrs per bus.

Labor time to install the correct tongue, if required, on driver's seat belts with the tongue side attached to the seat is 0.2hrs per bus.

Labor time to install the correct tongue, if required, on driver's seat belts with the tongue side attached to the floor is 0.4hrs per bus.

BLUE BIRD BODY COMPANY

P.O. Box 937 – 402 Blue Bird Blvd – Fort Valley, Georgia – (478) 825-2021



BLUE BIRD

Page 2

R12VH

When recall R12VH has been completed, reimbursement for labor may be obtained by completing the enclosed **pink** request for reimbursement sheet provided and returning it along with the **“R12VH Inspection and Parts Order Form”** to Blue Bird in the enclosed **pink** postage prepaid envelope.

If the modifications directed by this notification were performed on your bus prior to the receipt of this recall notification, complete and sign the recall reply sheet and attach a copy of the work order/invoice. Mail the documents in the **pink** self-addressed postage paid envelope included with the recall notification to Blue Bird for warranty consideration. Reimbursements will be made in accordance with the requirements of the National Highway Transportation Safety Act, Title 49 Code of Federal Regulations, Parts 573 and 577.

Federal law requires that any vehicle lessor receiving this recall notice must forward a copy of this notice to the lessee within ten days.

If Blue Bird Body Company should fail to or is unable to remedy this condition without charge to you, you may contact:

**ADMINISTRATOR
NATIONAL HIGHWAY TRAFFIC SAFETY ADMINISTRATION
1200 NEW JERSEY AVENUE, SE
WASHINGTON, D.C. 20590**

Or, you may call The National Highway Traffic Safety Administration toll free at:

1-888-327-4236 TTY 1-800-424-9153 Or, go to: [HTTP://WWW.SAFERCAR.GOV](http://WWW.SAFERCAR.GOV)

Questions regarding this recall campaign should be directed to me at (478) 822-2242.

Thank you,

Bill Coleman
Corporate Recall Administrator



Driver's Seat Belt Buckle Mismatch

RECALL

Models Affected: Certain 2013 Model Year "Vision" and "All-American"

ISSUE

The driver's seat belt tongue and buckle may be mismatched which could cause non-compliance with FVMSS 209 "Seat Belt Assemblies" S4.4 "Requirements for Assembly Performance".

CORRECTIVE ACTION

Inspect for proper match of seat belt tongue and buckle. If incorrect, change buckle to match the seat belt tongue.

PROCEDURE

WARNING: Always follow all Federal, State, Local and Shop safety standards and use proper safety equipment when performing these procedures.

INSPECTION PROCEDURE

1. Compare the driver's seat belt tongue and buckle to the photos below.

Notice the wide tongue and notched buckle release

Notice the narrow tongue and notched buckle release

CORRECT

INCORRECT

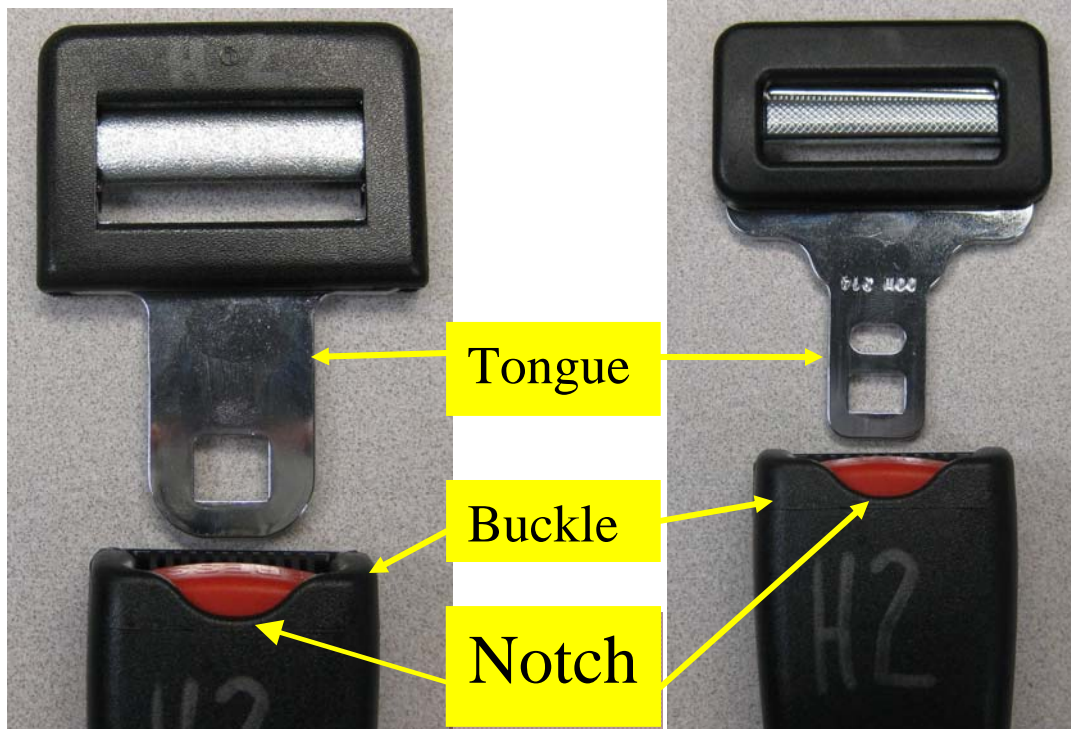

R 1 2 V H
R E C A L L C A M P A I G N



Driver's Seat Belt Buckle Mismatch

RECALL

Notice the narrow tongue and flat release.

Notice the wide tongue and flat release.

CORRECT

INCORRECT

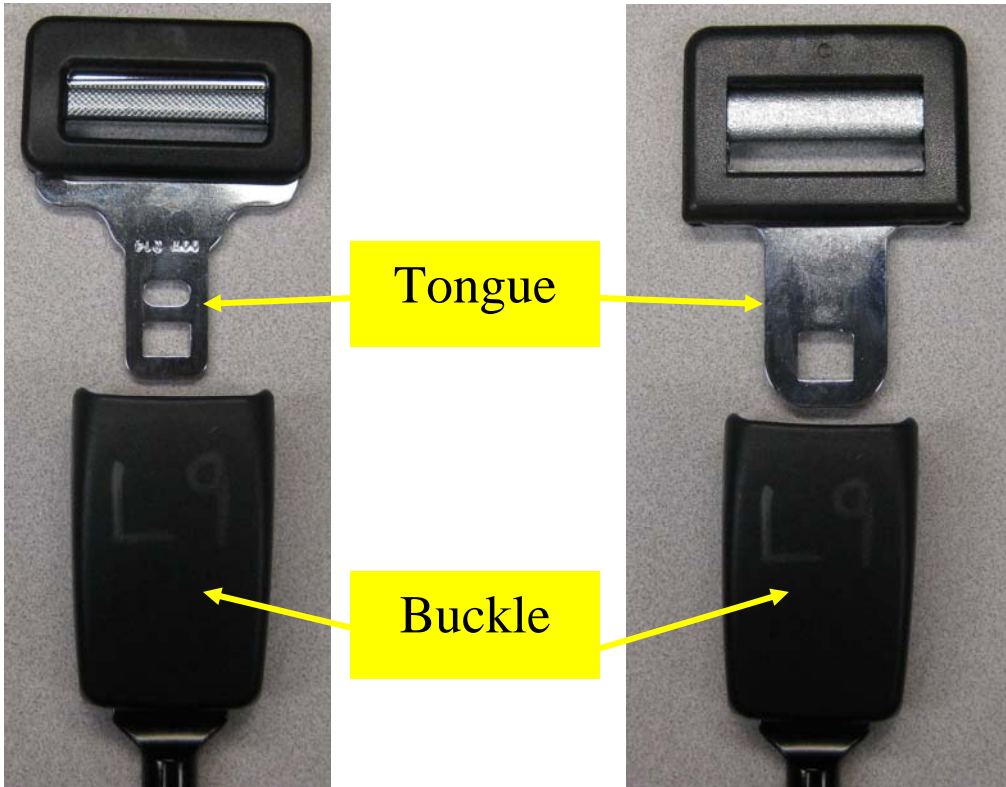

2. If the buckles are correct. Complete the Inspection Form on Page 5 and return to Blue Bird. No further action is required.

Modification Procedure

There are two modification procedures, only one will be applicable to each bus.

If the buckle end of the driver's seat belt is bolted to the driver's seat frame, refer to "Modification Instructions A".

If the buckle end of the driver's seat belt is bolted directly to the floor, refer to "Modification Instructions B".

If replacement buckle ends are required, complete the attached "R12VH Inspection and Parts Order Form" and return to Blue Bird. When ordering parts enter the body number and which type tongue and buckle ends are found on your bus. The correct buckle end will be shipped to you via UPS.



Driver's Seat Belt Buckle Mismatch

RECALL

Modification Instructions A

1. Park the bus on a level surface, apply parking brakes, remove ignition key.
2. Locate driver's seat belt buckle on right side of driver's seat. Remove and retain the 7/16" bolt securing the buckle to the seat frame. Discard the lock nut and buckle.
3. Install new buckle with new lock nut and torque to 37-41 ft- lbs. Verify belt tongue locks securely into buckle and matches per previous photos.

Reference installation drawing below as viewed from the rear of the driver's seat.

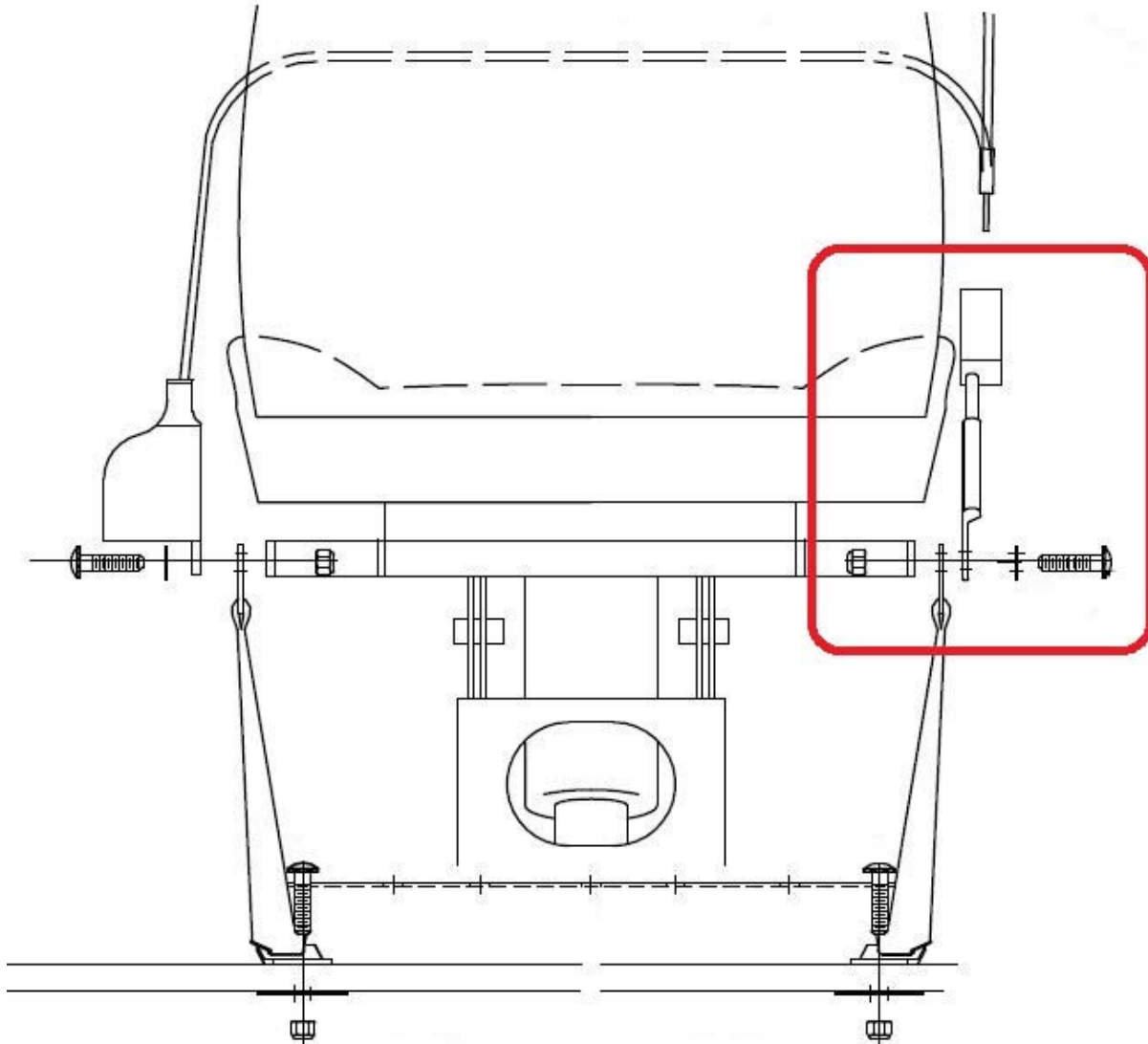

R I 2 V H

R E C A L L C A M P A I G N



Driver's Seat Belt Buckle Mismatch

RECALL

Modification Instructions B

1. Park the bus on a level surface, apply parking brakes, remove ignition key, and chock wheels.
2. Locate driver's seat belt buckle on right side of driver's seat. Remove and retain the 7/16" bolt securing the buckle to the floor of the bus. Discard the lock nut and buckle.
3. Install new buckle with new lock nut and torque to 37-41 ft-lbs. Verify the buckle is routed through the cable stay, belt tongue locks securely into buckle and matches per previous photos.

Reference installation drawing below as viewed from the rear of the driver's seat.

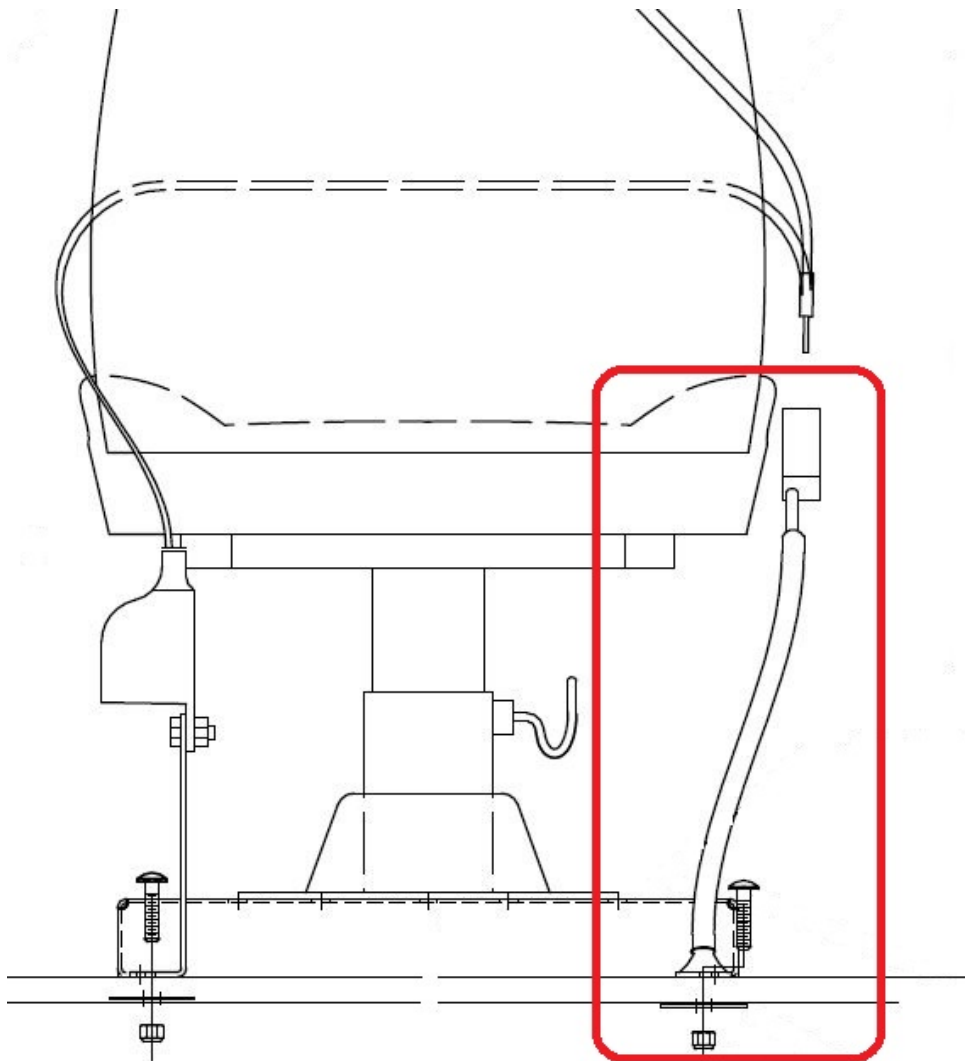

R I 2 V H

R E C A L L C A M P A I G N



Driver's Seat Belt
Buckle Mismatch

RECALL

R12VH Inspection and Parts Order Form

Enter the Blue Bird body number and check type of tongue and buckle found on your bus.

| Body Number | Type Tongue | | Type Buckle | |
|-------------|-------------|--------|-------------|------|
| | Wide | Narrow | Notched | Flat |
| | | | | |
| | | | | |
| | | | | |
| | | | | |
| | | | | |
| | | | | |
| | | | | |
| | | | | |
| | | | | |
| | | | | |

Ship replacement buckle(s), if needed, to:

Name of School or Company

Shipping Address (No P.O. Boxes)

City, State, Zip

Telephone Number

Your Name

R
I
2
V
H

R
E
C
A
L
L
C
A
M
P
A
I
G
N