



Michael A. Berardi
Director
Service Engineering Operations
Ford Customer Service Division

Ford Motor Company
P. O. Box 1904
Dearborn, Michigan 48121

July 16, 2012

TO: All U.S. Ford and Lincoln Dealers

SUBJECT: **DEMONSTRATION / DELIVERY HOLD - Safety Recall 12S34**
Certain 2013 Model Year Escape Vehicles
Console Trim Panel Clearance to Pedals

REF : DEMONSTRATION / DELIVERY HOLD Advance Notice - Safety Recall 12S34
Dated July 5, 2012

AFFECTED VEHICLES

Certain 2013 model year Escape vehicles built at the Louisville Assembly Plant from March 8, 2012 through June 7, 2012. Affected vehicles are identified in OASIS. In addition, for a list of vehicles assigned to your dealership, visit <https://web.fsavinlists.dealerconnection.com>.

REASON FOR THIS SAFETY RECALL

In some of the affected vehicles, a spacer pad under the carpet may have been mispositioned during installation, reducing the clearance between the floor console trim panel and the brake pedal. In certain vehicles, reduced clearance in this area may result in the operator's foot contacting the side of the brake pedal while transferring the foot from the accelerator pedal to the brake pedal, potentially increasing stopping distance and increasing the risk of a crash.

SERVICE ACTION

Before demonstrating or delivering any of the vehicles involved in this recall, dealers are to remove the carpet spacer and install a new LH floor console side trim panel containing a revised surface contour. Note that both operations are required to complete this service action. This service must be performed on all affected vehicles at no charge to the vehicle owner.

OWNER NOTIFICATION MAILING SCHEDULE

Owner Letters are expected to be mailed the week of July 23, 2012. Dealers should repair any affected vehicles that arrive at their dealerships, whether or not the customer has received a letter.

PLEASE NOTE:

Federal law requires dealers to complete this recall service before a new vehicle is delivered to the buyer or lessee. Violation of this requirement by a dealer could result in a civil penalty of up to \$6,000 per vehicle. Correct all vehicles in your new vehicle inventory before delivery.

ATTACHMENTS

- Attachment I: Administrative Information
- Attachment II: Labor Allowances and Parts Ordering Information
- Attachment III: Technical Information
- Owner Notification Letter (when available)

QUESTIONS & ASSISTANCE

Special Service Support Center (Dealer Assistance Only) 1-800-325-5621
Special Service Support Center (Parts Ordering) 1-800-207-2444

Sincerely,



Michael A. Berardi

DEMONSTRATION / DELIVERY HOLD - Safety Recall 12S34

Certain 2013 Model Year Escape Vehicles
Console Trim Panel Clearance to Pedals

OASIS ACTIVATED?

Yes, OASIS was activated on July 5, 2012.

FSA VIN LIST ACTIVATED?

Yes, FSA VIN list is available through <https://web.fsavinlists.dealerconnection.com>. Owner names and addresses will be available by July 30, 2012.

NOTE: Your FSA VIN list may contain owner names and addresses obtained from motor vehicle registration records. The use of such motor vehicle registration data for any purpose other than in connection with this recall is a violation of law in several states, provinces, and countries. Accordingly, you must limit the use of this listing to the follow-up necessary to complete this recall.

STOCK VEHICLES

Correct all affected units in your new vehicle inventory before delivery.

SOLD VEHICLES

- Owners of affected vehicles will be directed to dealers for repairs.
- Immediately contact any of your affected customers whose vehicles are not on your VIN list but are identified in OASIS. Give the customer a copy of the Owner Notification Letter (when available) and schedule a service date.
- Correct other affected vehicles identified in OASIS which are brought to your dealership.

TITLE BRANDED / SALVAGED VEHICLES

Affected title branded and salvaged vehicles are eligible for this recall.

RELATED DAMAGE

If a related damage condition exists that you believe to be caused by the covered condition, call the Special Service Support Center to request approval **prior** to the repair of any related damage. Requests for approval after completion of the repair will not be granted. Ford Motor Company reserves the right to deny coverage for related damage in cases where the vehicle owner has not had this recall performed on a timely basis.

ADDITIONAL LABOR TIME

- If a condition exists that requires additional labor to complete the repair, call the Special Service Support Center to request approval **prior** to performing any additional labor. Requests for approval after completion of the repair will not be granted.
- If you encounter aftermarket equipment or modifications to the vehicle which might prevent the repair of the covered condition, call the Special Service Support Center.

DEMONSTRATION / DELIVERY HOLD - Safety Recall 12S34

Certain 2013 Model Year Escape Vehicles
Console Trim Panel Clearance to Pedals

OWNER REFUNDS

Refunds are not authorized for this program.

RENTAL VEHICLES

The use of rental vehicles is not authorized for this program.

CLAIMS PREPARATION AND SUBMISSION

- Enter claims using Direct Warranty Entry (DWE).
- Refer to ACESII manual for claims preparation and submission information.
- Related damage must be claimed on a repair line that is separate from the repair line on which the FSA is claimed. Related damage requires prior approval from the Special Service Support Center.
- "MT" labor should be submitted on a separate repair line with the related damage flag checked. "MT" labor requires prior approval from the Special Service Support Center.

DEMONSTRATION / DELIVERY HOLD - Safety Recall 12S34

Certain 2013 Model Year Escape Vehicles
Console Trim Panel Clearance to Pedals

LABOR ALLOWANCES

Description	Labor Operation	Labor Time
Replace LH Floor Console Side Trim Panel	12S34B	0.4 Hour(s)

PARTS REQUIREMENTS / ORDERING INFORMATION

To ensure an equitable distribution of service parts, there will be a one-time seed stock to dealers covering 100% of their stock vehicle inventory the week of July 16, 2012.

To manage part availability, dealers must contact the Special Service Support Center Parts Order Line at 1-800-207-2444 to order additional parts.

When calling to place an order, please be prepared to provide dealer P&A code and VIN.

Dealers will be notified via a DOES II communication if circumstances warrant a change in part supply strategy and when open ordering resumes.

Part Number	Description	Quantity
CJ5Z-7804619-AC	LH Floor Console Side Trim Panel (Tan)	1
CJ5Z-7804619-AD	LH Floor Console Side Trim Panel (Black)	1

The DOR/COR number for this recall is 50476.

Questions regarding parts should be directed to the Special Service Support Center Parts Order Line (1-800-207-2444) or E-mailed to: Ford@Renkim.com.

DEALER PRICE

For latest prices, refer to DOES II.

EXCESS STOCK RETURN

Excess stock returned for credit must have been purchased from Ford Customer Service Division in accordance with Policy Procedure Bulletin 4000.

CERTAIN 2013 MODEL YEAR ESCAPE VEHICLES — CONSOLE TRIM PANEL CLEARANCE TO PEDALS

OVERVIEW

A spacer pad under the carpet may have been mispositioned during installation, reducing the clearance between the floor console trim panel and the brake pedal. Dealers are to remove the carpet spacer and install a new LH floor console side trim panel containing a revised surface contour. Note that both operations are required to complete this service action.

SERVICE PROCEDURE

1. Remove the lower instrument panel (IP) trim panel. For additional information, refer to Workshop Manual (WSM), Section 501-12. See Figure 1.

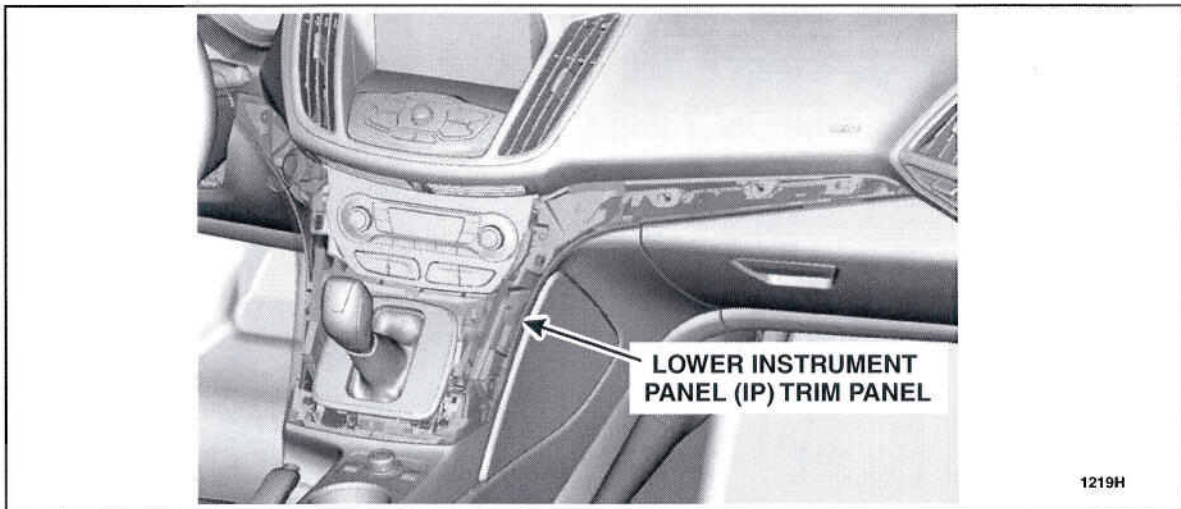

FIGURE 1

2. Open the floor console stowage bin door.



3. Remove the floor console latch trim panel. See Figure 2.

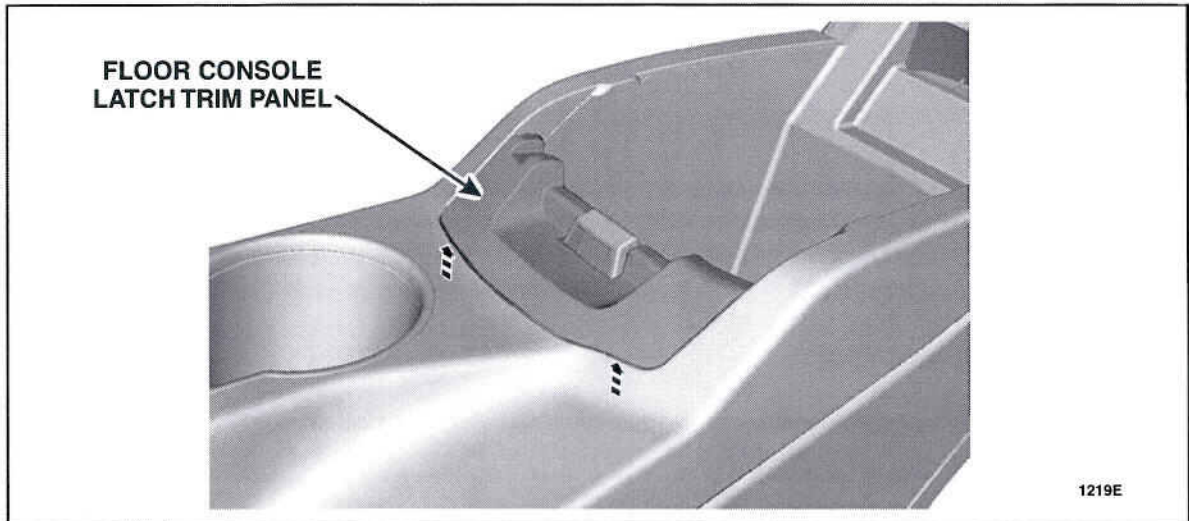

FIGURE 2

4. Position the parking brake handle upward and use a suitable trim tool to remove the parking brake handle trim. See Figure 3.

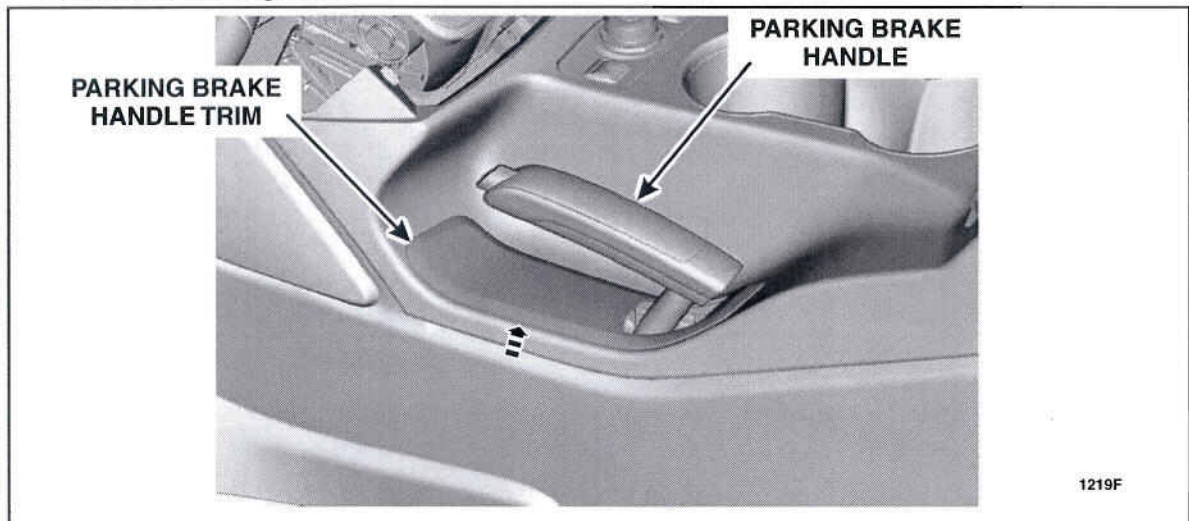

FIGURE 3



5. Position the floor console upper trim panel aside. See Figure 4.
- a. Remove the screw.
 - b. Detach the clips and position aside.

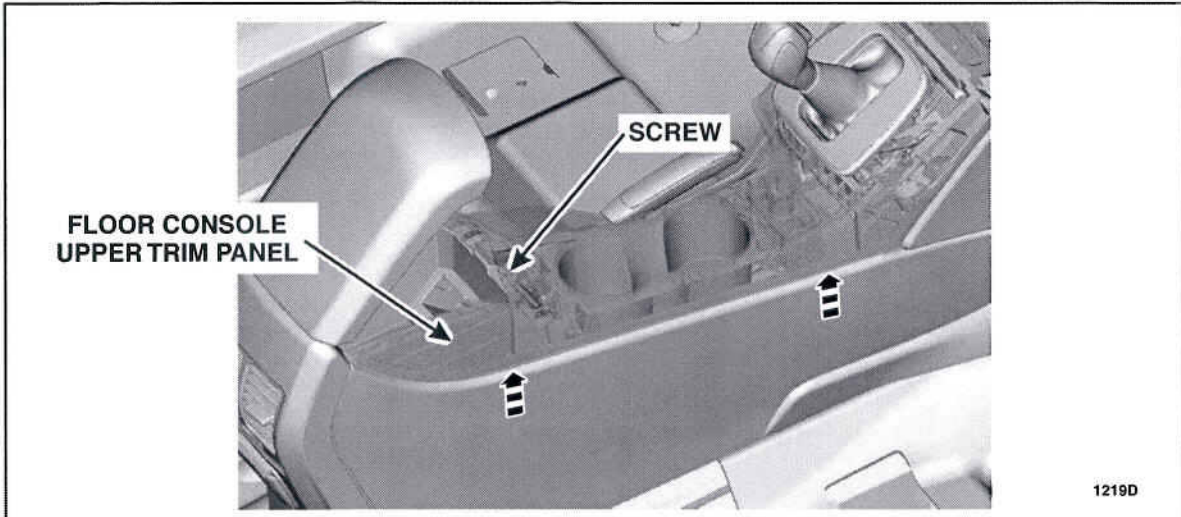

FIGURE 4

6. Remove the scrivet cover and remove the scrivet from the LH floor console side trim panel. See Figure 5.

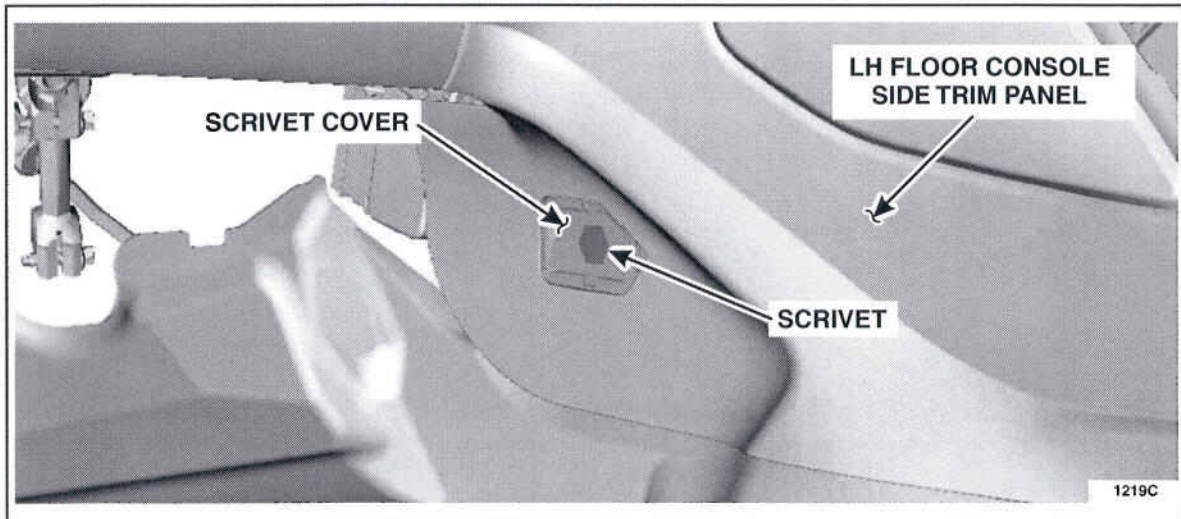

FIGURE 5



7. Remove and discard the LH floor console side trim panel. See Figure 6.
- a. Remove the screw.
 - b. Detach the clips and remove.

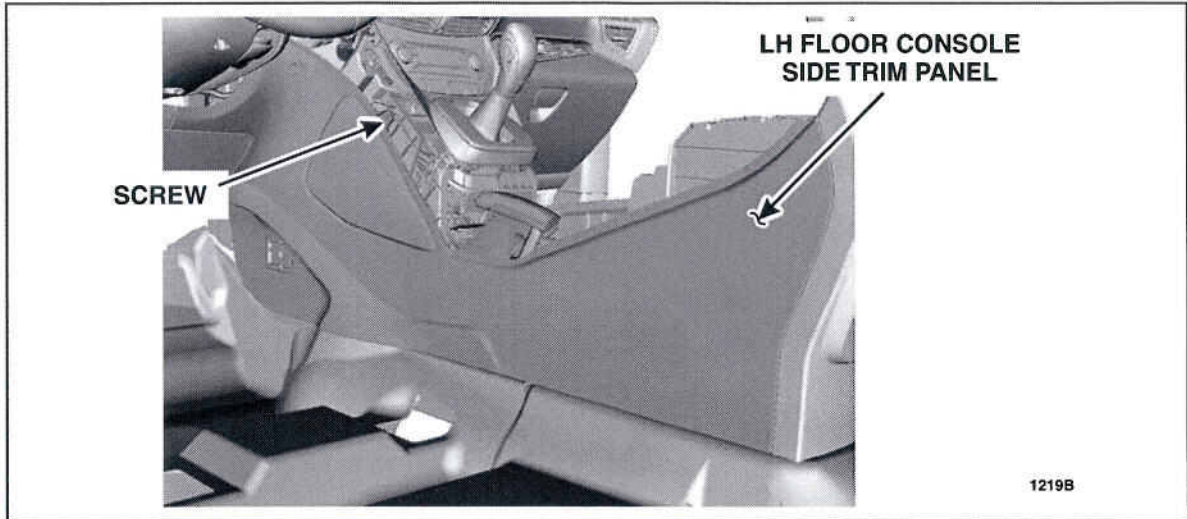

FIGURE 6

8. Position aside the carpet at the instrument panel brace. Remove and discard the 107x152 mm (4x6 in) carpet spacer section. See Figure 7.

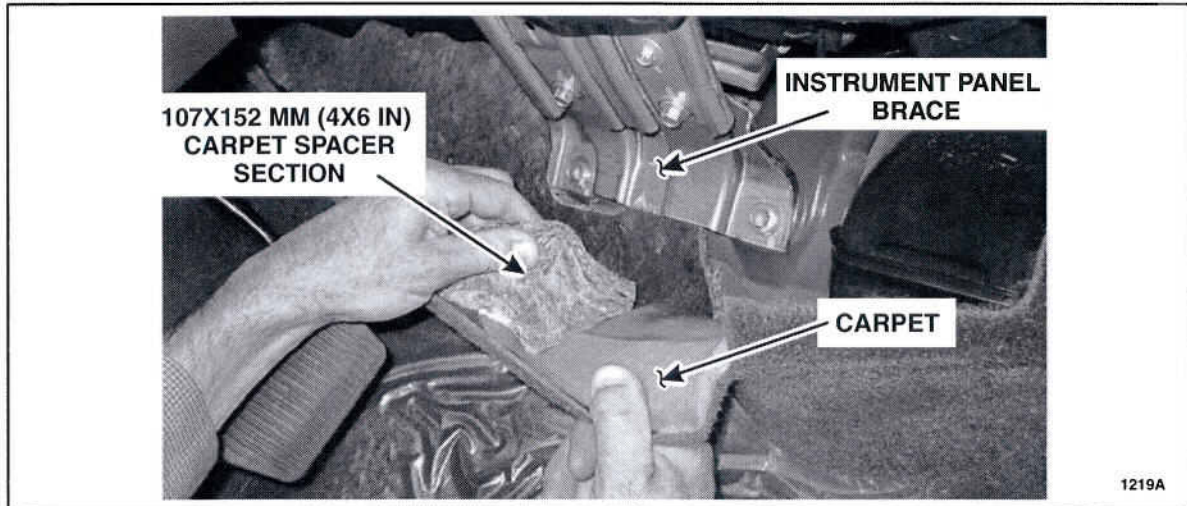

FIGURE 7



9. Install a *new* LH floor console side trim panel containing a revised surface contour. See Figure 6.
 - a. Install and attach the clips.
 - b. Install the screw.
10. Install the push pin and install the push pin cover. See Figure 5.
11. Position the floor console upper trim panel back. See Figure 4.
 - a. Position back and attach the clips.
 - b. Install the screw.
12. Install the parking brake handle trim and position the parking brake handle downward. See Figure 3.
13. Install the floor console latch trim panel. See Figure 2.
14. Close the floor console stowage bin door.
15. Install the lower IP trim panel. For additional information, refer to WSM, Section 501-12. See Figure 1.

