



Volvo Cars of North America, LLC

1 Volvo Drive
P.O. Box 914
Rockleigh, NJ 07647
Phone: 201-768-7300
www.volvocars.us

Product Safety & Compliance

******* IMPORTANT VEHICLE RECALL NOTICE *******

DATE: March 08, 2012

TO: All U.S. and Canadian Volvo Retailers

RE: Volvo Recall 250
Certain Model Year 2012 S60, XC60, S80 and XC70 Vehicles

The sale or lease of defective or non-compliant motor vehicles or equipment is prohibited by law. Vehicles in retailer inventory must be remedied prior to sale. Repair information is attached to this communication.

Volvo Cars of North America, LLC (Volvo) has decided to conduct a voluntary safety recall on certain model year 2012 S60, XC60, S80 and XC70 vehicles.

Volvo has identified that the wiring harness under the driver and or passenger front seat may not have been properly secured to the seat frame during vehicle assembly. The wiring harness under the front seat on affected vehicles may get caught on the audio or back up camera amplifier when the front seat is adjusted. If this condition occurs, the wiring harness connector may detach and the Supplemental Restraint System (SRS) may not function as intended. The SRS warning lamp in the instrument panel will illuminate and the message "SRS service required urgent" will be displayed in the Driver Information Module (DIM).

The following components may be affected:

- Seat belt buckle, if the signal is absent the front airbag(s) will deploy as if the person in the seat is unbelted.
- Side Impact Protection System (SIPS), if signal is absent the side impact air bag will not deploy.
- Occupant Weight Sensor (OWS) (only on front passenger seat), if signal is absent the SRS system will not deploy the passenger front airbag due to that it cannot determine if a small person/child seat is present or not in the passenger seat.
- Seat Track Position Sensor (STPS), if signal is absent the SRS system cannot determine the position of the seat and the front air bag will deploy with full power.
- Pelvis Lap Protection (PLP), if signal is absent the lap belt pretensioner will not deploy.

The corrective action will be to inspect the seat wiring under both front seats, and **if necessary** secure the wiring per TJ 26012.

OWNER NOTIFICATION

Owner notification is scheduled to begin in March.

RETAILER RESPONSIBILITIES

Retailers must perform this recall campaign on eligible vehicles regardless of miles/kilometers or vehicle age. All work performed under this recall is free of charge to the owner.

In the event that a customer does not have a notification letter, the owner is not to be refused the work. Your regional representative will follow up to ensure that this recall campaign is proceeding smoothly.

A complete description of the recall campaign requirements and claim submission procedures is below. It is the retailer's responsibility to review the details provided in the materials listed below with all involved personnel.

- Service Manager Bulletin
- Technical Journal
- Parts Bulletin

Your cooperation in completing this important recall is greatly appreciated.

Drive Safely,



Adam Kopstein
Manager, Product Safety and Compliance
201-768-7300 ext# 7908
akopstei@volvocars.com

<h1 style="margin: 0;">VOLVO</h1> <h2 style="margin: 0;">Service Manager Bulletin</h2>				TITLE:		GROUP:	NO:
				Recall 250: Front Seat Wiring Inspection		85	250
				Model Year 2012 S60, XC60, S80, XC70		ISSUING DEPARTMENT:	
						Warranty	
				REFERENCE BULLETINS:		DATE:	
				TJ 26012, PB 85-250		YEAR	MONTH
Service Person- nel: read and initial.	SERVICE MANAGER	SERVICE WRITER	WARRANTY ADMINISTRATOR	2012		03	08
				Page 1 of 3			

This Information Supersedes the Inspection Prior to Delivery Notice Released to VRC² on 02/27/12

- A. **RECALL 250 DESCRIPTION**
- B. **VEHICLES INVOLVED**
- C. **PARTS INFORMATION/PARTS RETURN**
- D. **OWNER NOTIFICATION**
- E. **VEHICLES IN RETAILER INVENTORY**
- F. **RETAILER RESPONSIBILITY**
- G. **TECHNICIAN COMPETENCY REQUIREMENT**
- H. **CAMPAIGN REIMBURSEMENT PROCEDURES**

A. RECALL 250 DESCRIPTION

Volvo Cars of North America, LLC (Volvo) has decided to conduct a voluntary safety recall on certain model year 2012 S60, XC60, S80 and XC70 vehicles.

Volvo has identified that the wiring harness under the driver and or passenger front seat may not have been properly secured to the seat frame during vehicle assembly. The wiring harness under the front seat on affected vehicles may get caught on the audio or back up camera amplifier when the front seat is adjusted. If this condition occurs, the wiring harness connector may detach and the Supplemental Restraint System (SRS) may not function as intended. The SRS warning lamp in the instrument panel will illuminate and the message "SRS service required urgent" will be displayed in the Driver Information Module (DIM).

The following components may be affected:

- Seat belt buckle, if the signal is absent the front airbag(s) will deploy as if the person in the seat is unbelted.
- Side Impact Protection System (SIPS), if signal is absent the side impact air bag will not deploy.
- Occupant Weight Sensor (OWS) (only on front passenger seat), if signal is absent the SRS system will not deploy the passenger front airbag due to that it cannot determine if a small person/child seat is present or not in the passenger seat.

"Fixed Right — First Time"



- Seat Track Position Sensor (STPS), if signal is absent the SRS system cannot determine the position of the seat and the front air bag will deploy with full power.
- Pelvis Lap Protection (PLP), if signal is absent the lap belt pretensioner will not deploy.

The corrective action will be to inspect the seat wiring under both front seats, and **if necessary** secure the wiring per TJ 26012.

B. VEHICLES INVOLVED

NOTE: RETAILERS MUST CONFIRM VEHICLE ELIGIBILITY PRIOR TO BEGINNING THIS RECALL REPAIR.

Vehicle eligibility must be confirmed:

- Inquire in VRC² - Vehicle Warranty where the message "RECALL 250 - Inspect Front Seat Wiring (R89297) SMB 85-250" will appear for eligible vehicles.

All vehicles should be checked for any other incomplete recalls or service campaigns or service upgrades. All open Recall, Service Campaign or Service Action repairs should be completed.

RETAILER VEHICLE CAMPAIGN LIST

The "Unperformed Recall Report" will be posted on VRC² in the Reports Menu under the Service Tab. This report lists all affected vehicles that are on record as retailed/serviced or currently in stock at your facility with incomplete recalls and service campaigns, and is updated monthly.

C. PARTS INFORMATION / PARTS RETURN

Please refer to Parts Bulletin 85-250.

PARTS RETURN

Parts are not required to be returned for repairs done in accordance with this recall.

D. OWNER NOTIFICATION

Owner notification is scheduled to begin in March.

E. VEHICLES IN RETAILER INVENTORY

All vehicles in retailer inventory and qualifying for this recall must be repaired prior to a customer taking possession of the vehicle.

F. RETAILER RESPONSIBILITY

Retailers are to perform this recall on eligible vehicles regardless of mileage/kilometers or vehicle age. The repairs included in Recall 250 are free of charge to the owner. If a customer presents a recall or service campaign letter for a vehicle that is not found via the VRC² inquiry function, please verify that the letter applies to the customer's vehicle and call the Warranty Assistance Desk at 1-800-807-7712 for instructions. If the Warranty Assistance Desk verifies that the vehicle qualifies for the Recall or Service Campaign, please perform the repair and place the recall or service campaign letter in the customer's file. Under no circumstances should a customer be denied the required service without a confirmation from VCNA/VCCC.

G. TECHNICIAN COMPETENCY REQUIREMENT

The technician competency requirement for this campaign repair is: Level 1 Quality Tech.

H. CAMPAIGN REIMBURSEMENT PROCEDURES (LONG FORM APPLICATION)

Labor reimbursement allowance is effective at time of release and may change in the future.

Claim Type: R89297
Cause Code: 02
CSC Code: XW
Main OP: 85978
Failed Part: 983750

INSPECTION ONLY

<u>Operation Number</u>	<u>Repair Description</u>	<u>Qty</u>	<u>Labor Time</u>
85978	Inspect Wiring for BOTH Front Seats	1	0.2 Hrs

ADD OP# 85992 ONLY IF SECURING WIRING FOR FRONT SEAT IS NECESSARY

<u>Operation Number</u>	<u>Repair Description</u>	<u>Qty</u>	<u>Labor Time</u>
85992*	Secure Wiring Under 1 Front Seat	1	0.4 Hrs

* Use this operation number Quantity of 2 if both front seats require securing of wiring.

Title Recall 250: Front Seat Wiring Inspection
Ref No US26012.1.1 en-US
Issuer -
Partner 3 US 7510 Volvo Cars North America
Func Group 8521
Func Desc front seat, complete

Status Released
Status Date 2012-03-08
Issue Date 2012-03-06
Reference VIDA

Attachment

File Name	File Size
Repair.pdf	1.7360 MB

Vehicle Type

Type	Eng	Eng Desc	Sales	Body	Gear	Steer	Model Year	Plant	Chassis range	Struc Week Range
124							2012-2012		0151101-0155385	0-0
134							2012-2012		0076075-0103860	0-0
136							2012-2012		0118101-0127175	0-0
156							2012-2012		0237068-0271560	0-0

CSC Customer Symptom Codes

Code	Description
XW	Service action/Recall/Service action/Recall

DTC Diagnostic Trouble Codes

Text

CSC = Customer Symptom Code

DTC = Diagnostic Trouble Code

Note! If using a printed copy of this Technical Journal, first check for the latest online version.

DESCRIPTION:

Volvo has identified that the wiring harness under the driver and or passenger front seat may not have been properly secured to the seat frame during vehicle assembly. The wiring harness under the front seat on affected vehicles may get caught on the audio or back up camera amplifier when the front seat is adjusted. If this condition occurs, the wiring harness connector may detach and the Supplemental Restraint System (SRS) may not function as intended. The SRS warning lamp in the instrument panel will illuminate and the message "SRS service required urgent" will be displayed in the Driver Information Module (DIM).

The following components may be affected:

- Seat belt buckle, if the signal is absent the front airbag(s) will deploy as if the person in the seat is unbelted.
- Side Impact Protection System (SIPS), if signal is absent the side impact air bag will not deploy.
- Occupant Weight Sensor (OWS) (only on front passenger seat), if signal is absent the SRS system will not deploy the passenger front airbag due to that it cannot determine if a small person/child seat is present or not in the passenger seat.
- Seat Track Position Sensor (STPS), if signal is absent the SRS system cannot determine the position of the seat and the front air bag will deploy with full power.
- Pelvis Lap Protection (PLP), if signal is absent the lap belt pretensioner will not deploy.

PRODUCT MODIFICATION:

The corrective action will be to inspect the seat wiring under both front seats, and **only if necessary** secure the wiring per the instructions attached to this document.

SERVICE:

Check the cable harness position according to attached instruction.
If the cable harness is out of position adjust the cables according to attached instruction

To view TJ attachment continue to next page:

Volvo Car Customer Service	
	TJ Instruction
	No 26012
	Date March 2012 Issue 01
Title	Recall 250 Front Seat Wiring Inspection

Materials	Quantity	Part No.
Cable tie	6.0	983750

1.

Note! Some variation in the illustrations may occur, but the essential information is always correct



Title

Front seat harness

All specified vehicles must be inspected prior to retail sale.

Only if the inspection identifies an issue, please remedy per the repair instructions.

Inspection (facing rearward)

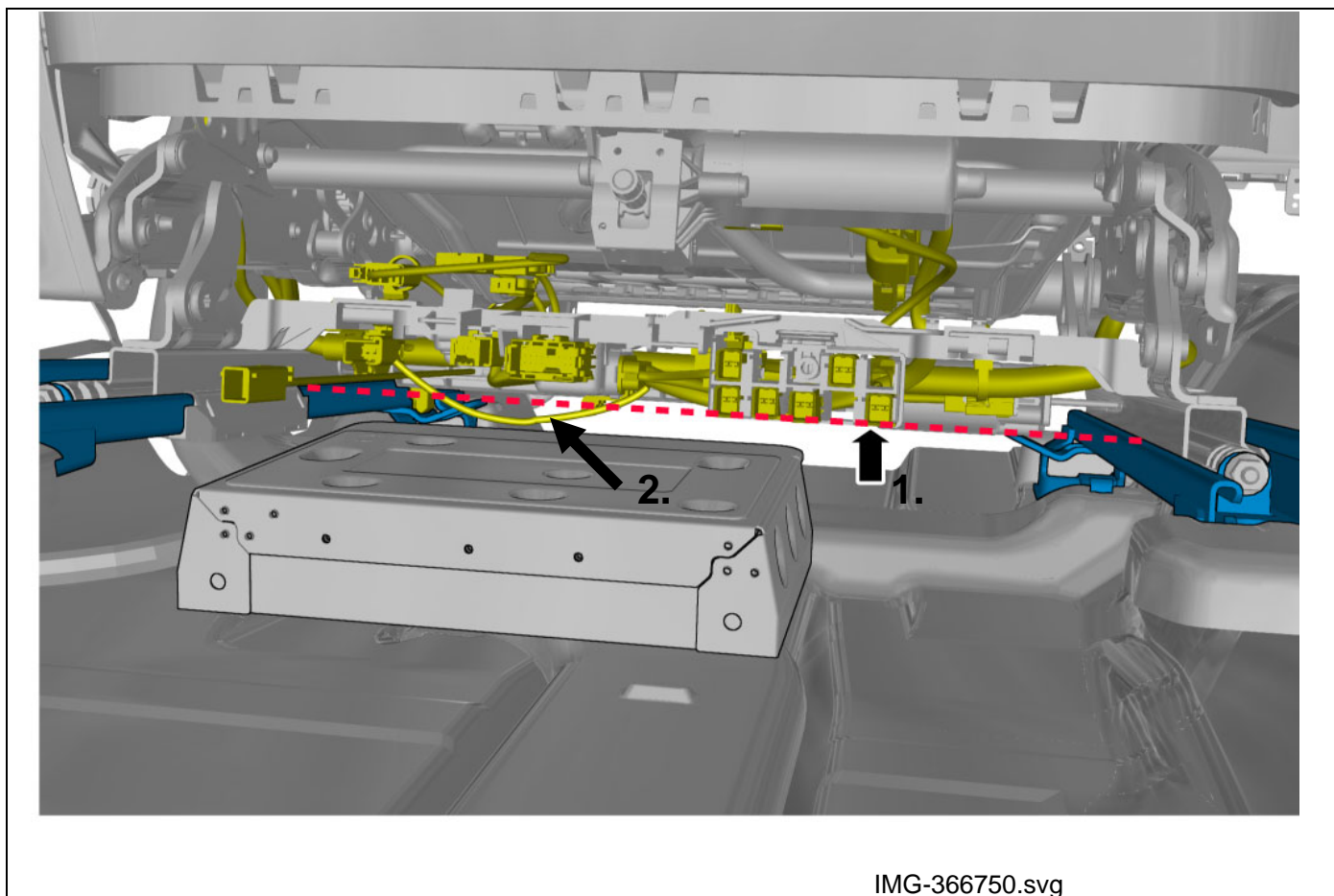

No wiring harness is to hang down below the dotted line (Arrow 1) with the exception of the wiring harness for the seat heater (Black Tube). The seat heater harness may hang down on some vehicles (Arrow 2), however the distance between the seat heater harness and the amplifier must be 5 mm (1/4") or more.

Note: Only the seat wiring harness is shown in the above illustration. The additional wiring harnesses from the vehicles main harness are not shown.

Repair Instructions

Remove front seat, refer to:
Removal, replacement and installation
8 - Body and interior
85 - Interior
852 - front seat, drivers seat, seat bench
type

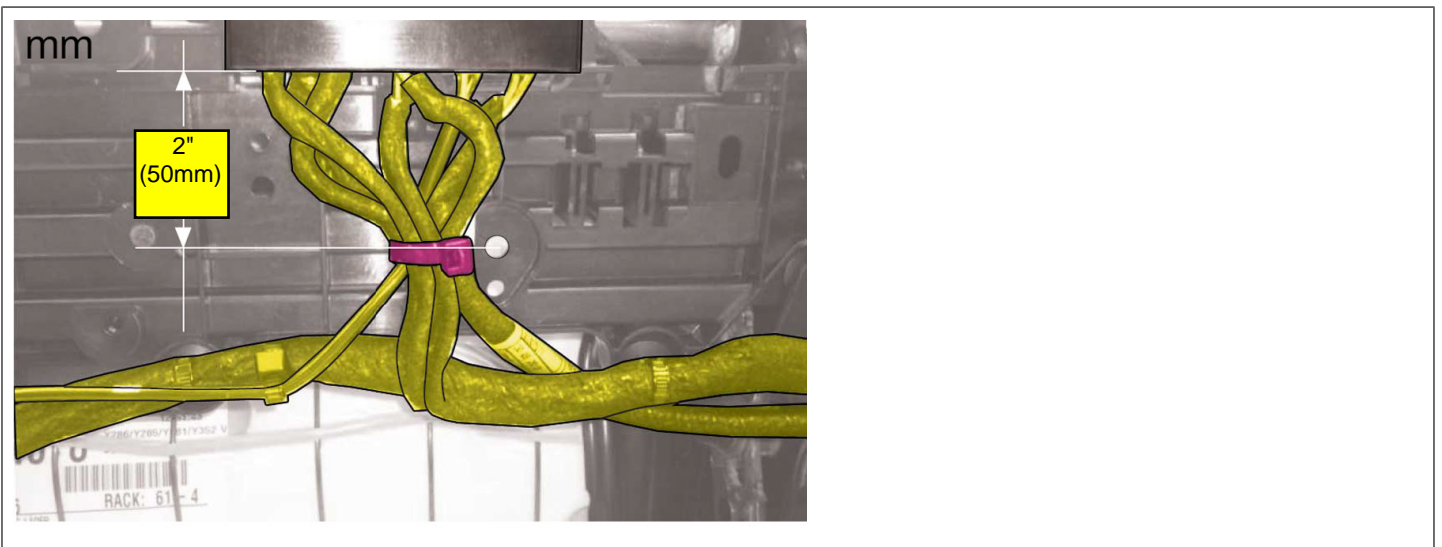
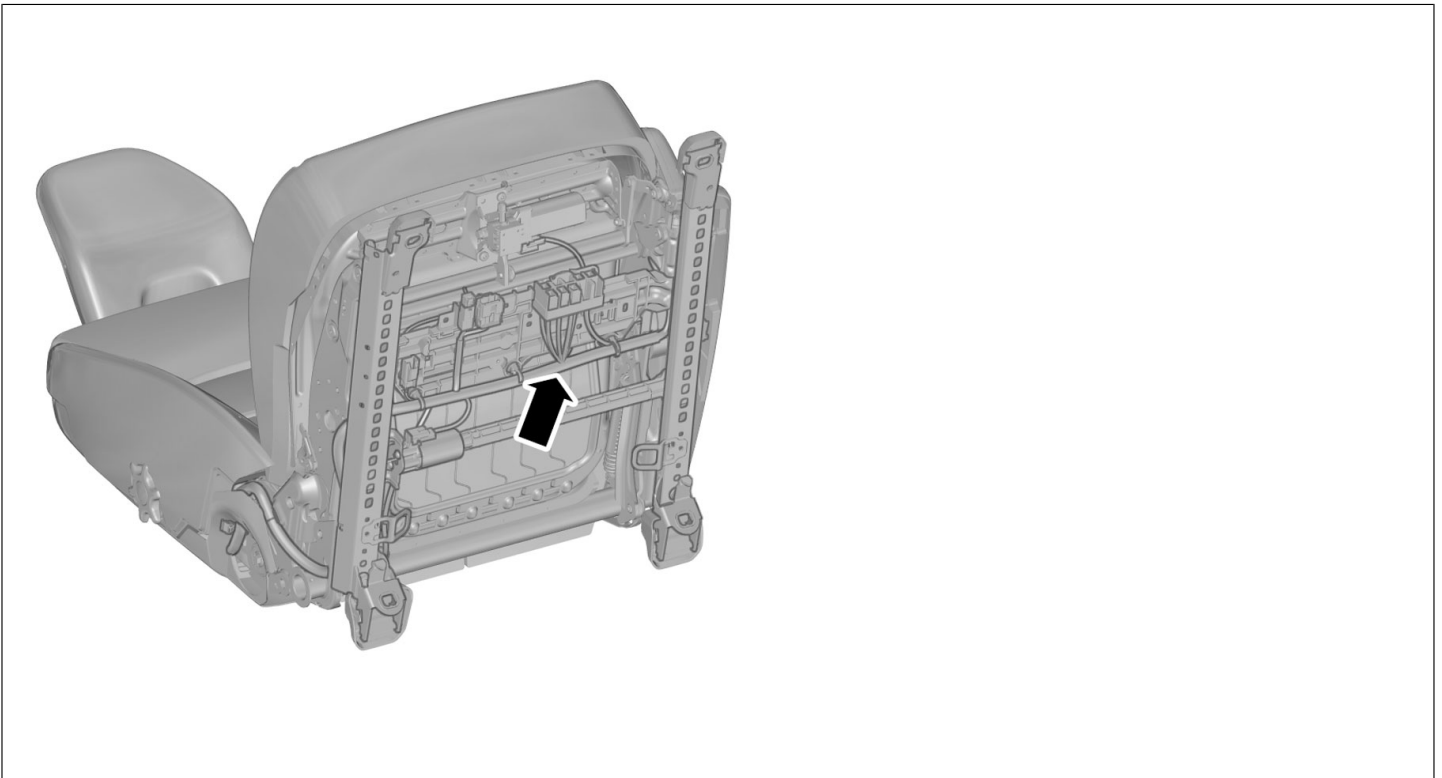

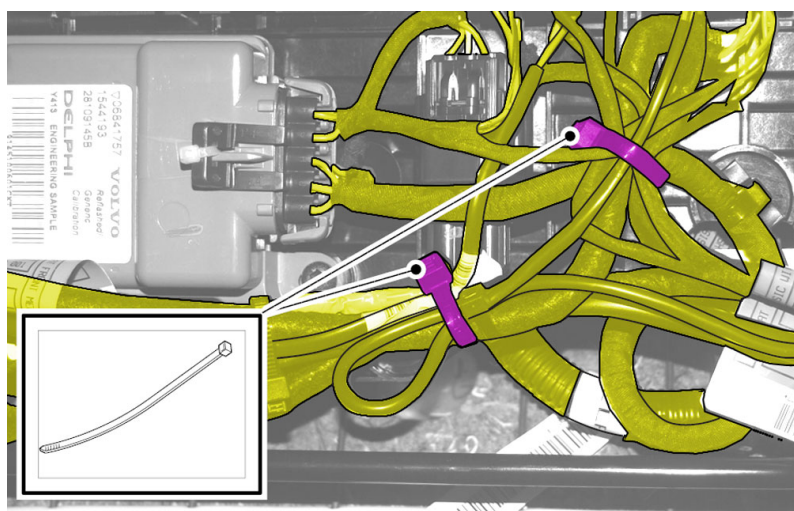

Note! Vehicles with Occupant Weight Sensor (OWS)

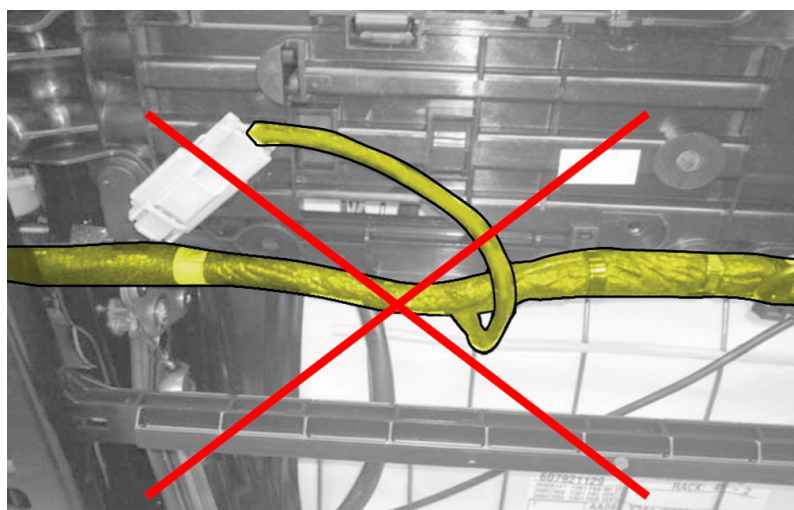

Note! Vehicles with Seat Ventilation

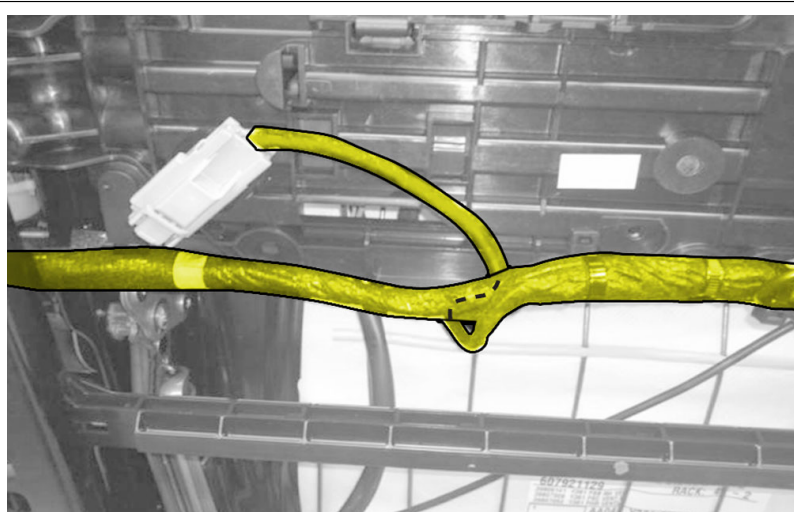

Note! Vehicles with Seat Ventilation

Vehicles with power seats

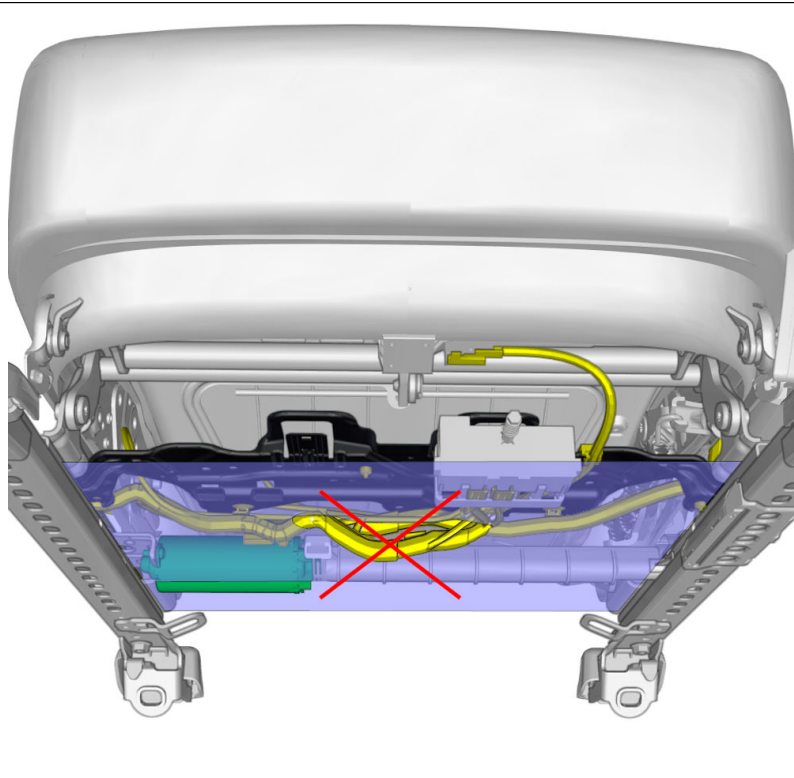

Caution! Make sure that the wiring harness does not catch.

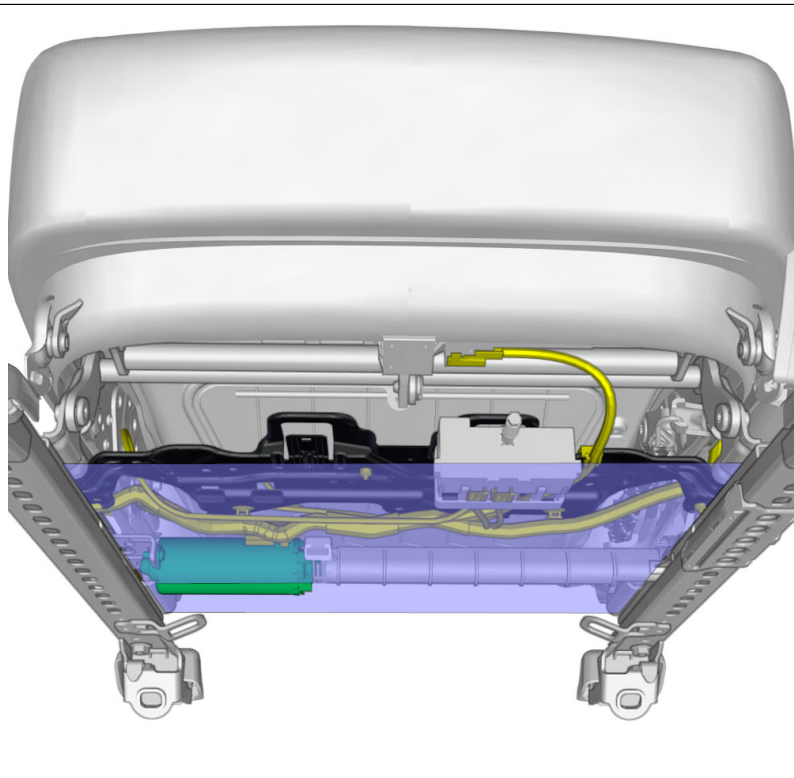

Note! Extra cable length must be secured using cable ties.

Vehicles without power seats

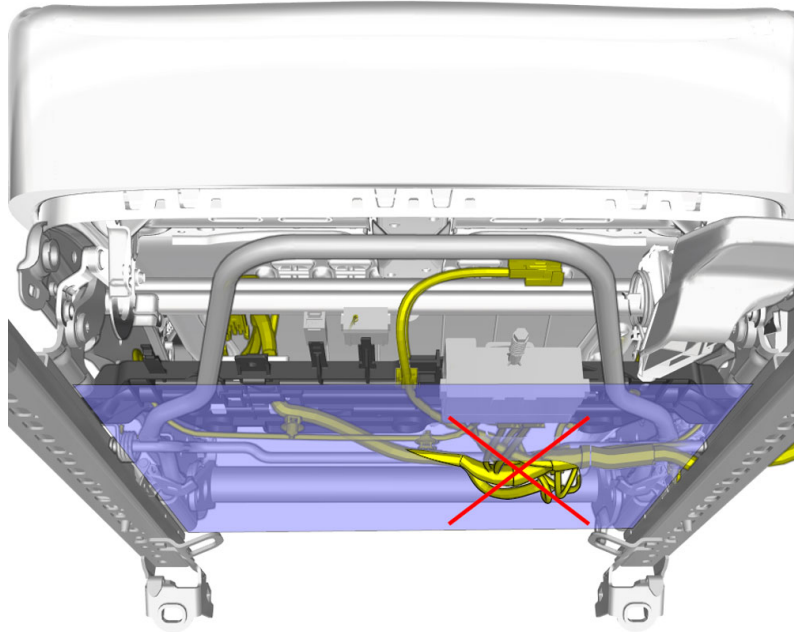

Caution! Make sure that the wiring harness does not catch.

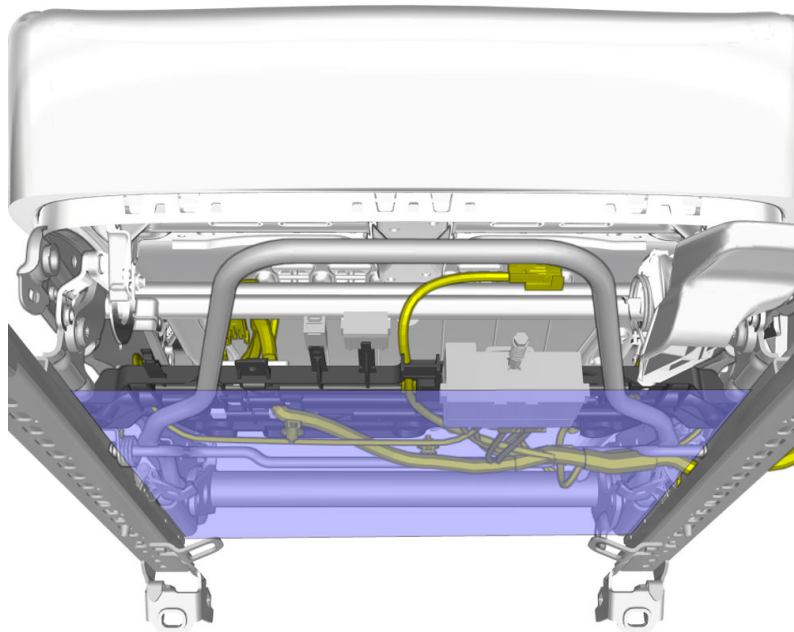

Note! Extra cable length must be secured using cable ties.

Check

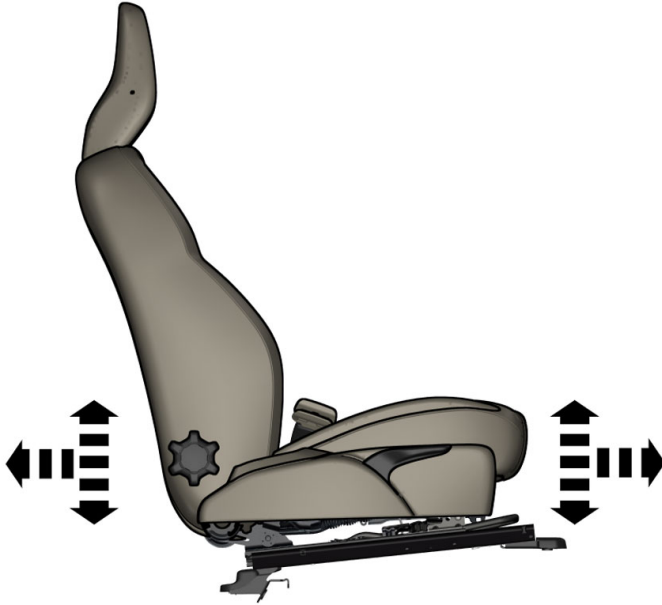

Caution! Make sure to reach all end positions.

Caution! Make sure that the wiring harness is not stretched.

Install the front seat, refer to:

Removal, replacement and installation

8 - Body and interior

85 - Interior

852 - front seat, drivers seat, seat bench type



Parts Bulletin

SUBJECT Recall 250: Front Seat Wiring Inspection Model Year 2012 S60, XC60, S80, XC70				GROUP 85		NO 250	
				MARKET United States, Canada		PAGE 1 of 1	
COPY TO / CIRCULATIONS (PLEASE INITIAL)							
GENERAL MGR	PARTS MGR	SERVICE MGR	SALES MGR	DATE	YEAR	MONTH	DAY
					2012	03	08

Reference Bulletins: TJ 26012
SMB 85-250

Volvo Cars of North America, LLC (Volvo) has decided to conduct a voluntary safety recall on certain model year 2012 S60, XC60, S80 and XC70 vehicles.

Volvo has identified that the wiring harness under the driver and or passenger front seat may not have been properly secured to the seat frame during vehicle assembly. The wiring harness under the front seat on affected vehicles may get caught on the audio or back up camera amplifier when the front seat is adjusted. If this condition occurs, the wiring harness connector may detach and the Supplemental Restraint System (SRS) may not function as intended. The SRS warning lamp in the instrument panel will illuminate and the message "SRS service required urgent" will be displayed in the Driver Information Module (DIM).

The following part numbers apply:

Part Number	Description	Qty
983750	Cable tie	*

* Part# 983750 Wire Ties are required only if the seat inspection reveals a need to secure the seat wiring. A maximum of 6 wire ties (3 per seat) is needed. **Most vehicles should only require an inspection.**

"Fixed Right — First Time"



Printed in USA on recycled paper containing a minimum of 50% wastepaper and 10% post-consumer waste.

© 2012 VOLVO CARS OF NORTH AMERICA, LLC