



Volvo Cars of North America, LLC

1 Volvo Drive
P.O. Box 914
Rockleigh, NJ 07647
Phone: 201-768-7300
www.volvocars.us

Product Safety & Compliance

February 27, 2012

IMMEDIATE VEHICLE INSPECTION / UPGRADE PRIOR TO SALE REQUIRED

TO: All U.S. and Canadian Volvo Retailers

RE: Seat Wiring Inspection Required Prior to Vehicle Delivery

Volvo Cars of North America, LLC (Volvo) on behalf of Volvo Car Corporation has decided that an inspection of the driver and front passenger seat wiring harness is required prior to vehicle delivery. This inspection is required on certain model year 2012 S60, S80, XC60, and XC70 vehicles identified in the attached eligible vehicle list.

UNSOLD VEHICLE LIST

All vehicles must be inspected prior to retail sale according to the attached method. If the inspection identifies an incorrectly routed seat wire harness, please remedy per the attached repair instructions.

Vehicles transferred or swapped to/from the original allocated retailer will need to be checked against the vehicle eligibility list attached.

Vehicles that have been delivered to customers prior to this notification will be addressed when additional information is available.

Claim submission instructions will be released once all the eligible vehicles are correctly marked in DCS Vehicle inquiry next week. Please hold all claims for reimbursement until this information is available.

If you have any questions about this or any other Field Service Action please contact me or any member of the Product Safety and Compliance office.

Regards,

A handwritten signature in blue ink, appearing to read "A. Kopstein".

Adam Kopstein
Manager, Product Safety & Compliance Office



Title

Front seat harness

All specified vehicles must be inspected prior to retail sale.
Only if the inspection identifies an issue, please remedy per the repair instructions.

Inspection (facing rearward)

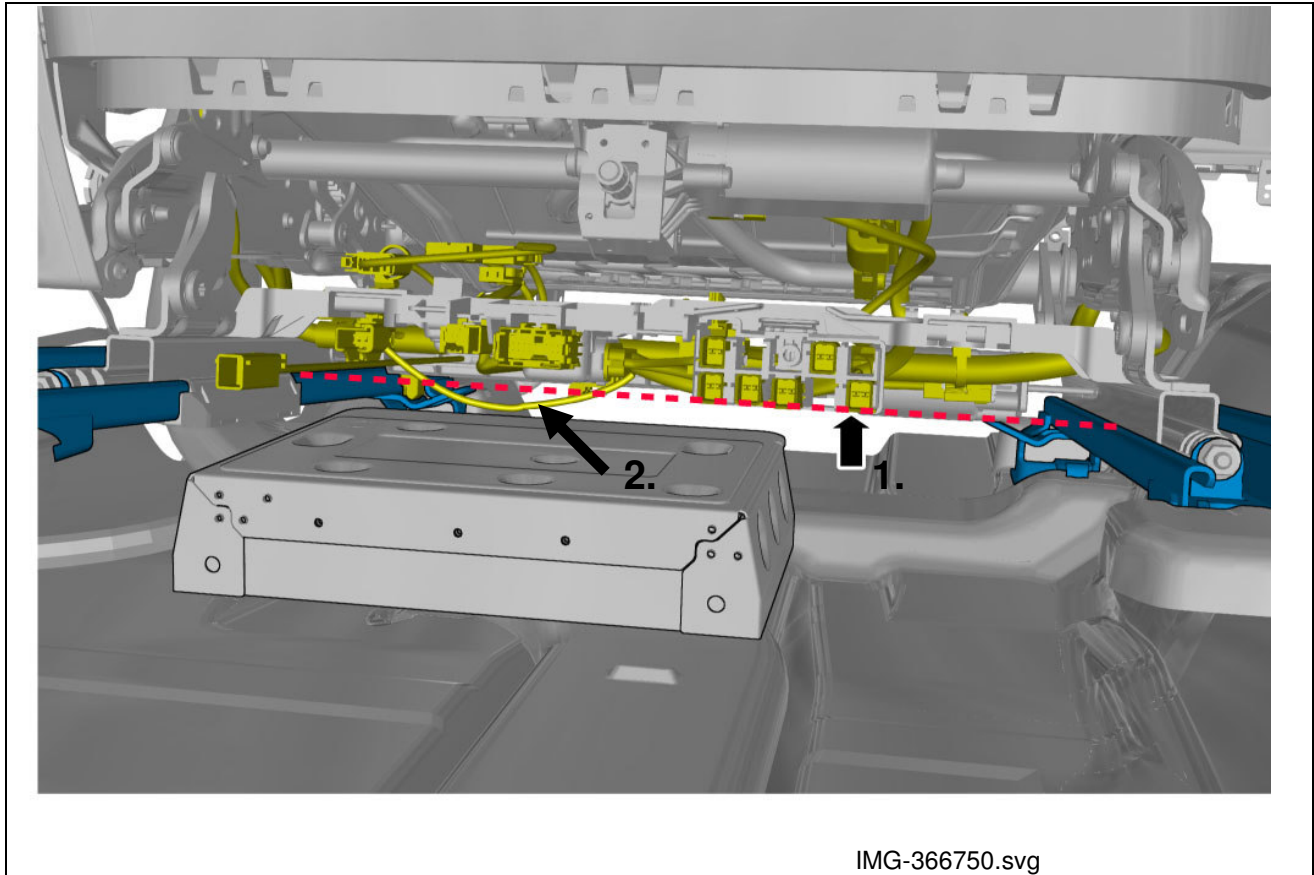

IMG-366750.svg

No wiring harness is to hang down below the dotted line (Arrow 1) with the exception of the wiring harness for the seat heater (Black Tube). The seat heater harness may hang down on some vehicles (Arrow 2), however the distance between the seat heater harness and the amplifier must be 5 mm (1/4") or more.

Note: Only the seat wiring harness is shown in the above illustration. The additional wiring harnesses from the vehicles main harness are not shown.

Volvo Car Customer Service		
	TJ Instruction	
	No 25330	
		Date February 2012 Issue 01
Title	Loose connectors in front seat cable harness	

Materials	Quantity	Part No.
Cable tie	6.0	983750

1.

Note! Some variation in the illustrations may occur, but the essential information is always correct

Adjustment

Remove front seat, refer to:
Removal, replacement and installation
8 - Body and interior
85 - Interior
852 - front seat, drivers seat, seat bench
type

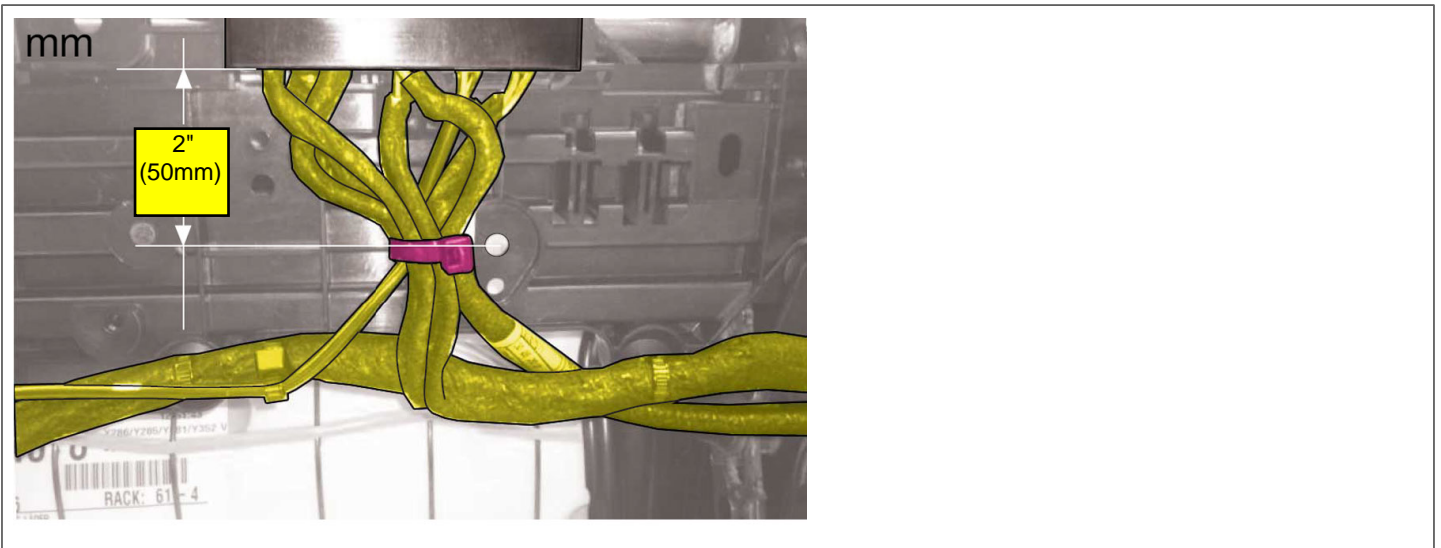
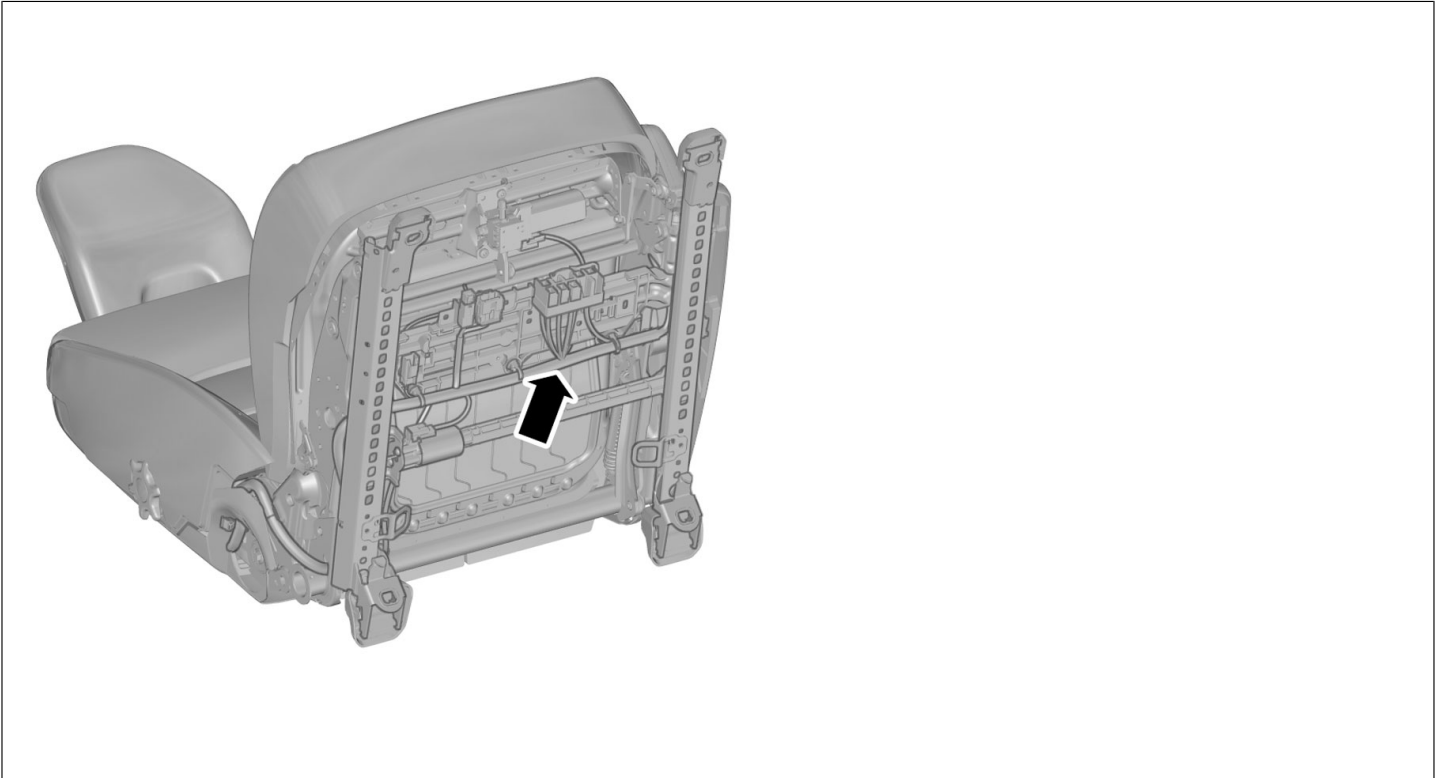

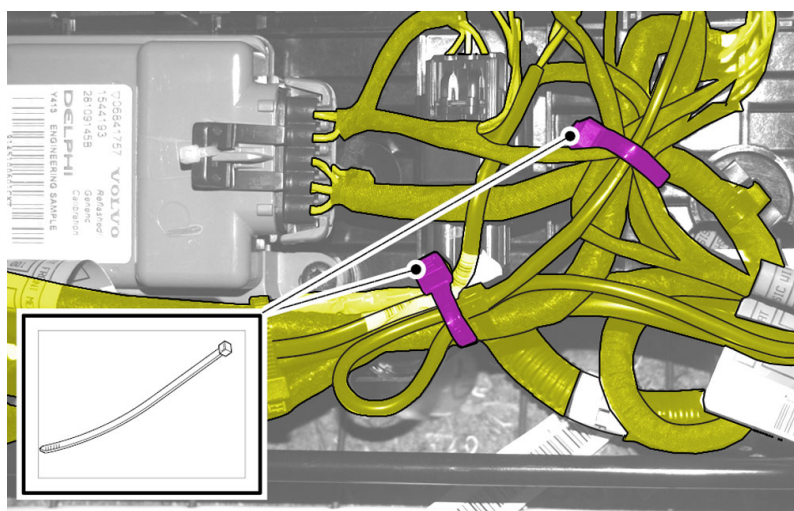

Note! Vehicles with Occupant Weight Sensor (OWS)

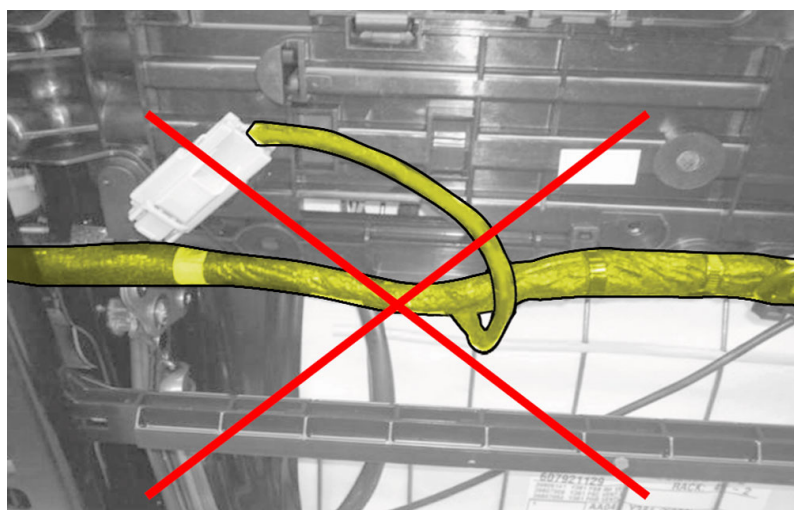

Note! Vehicles with Seat Ventilation

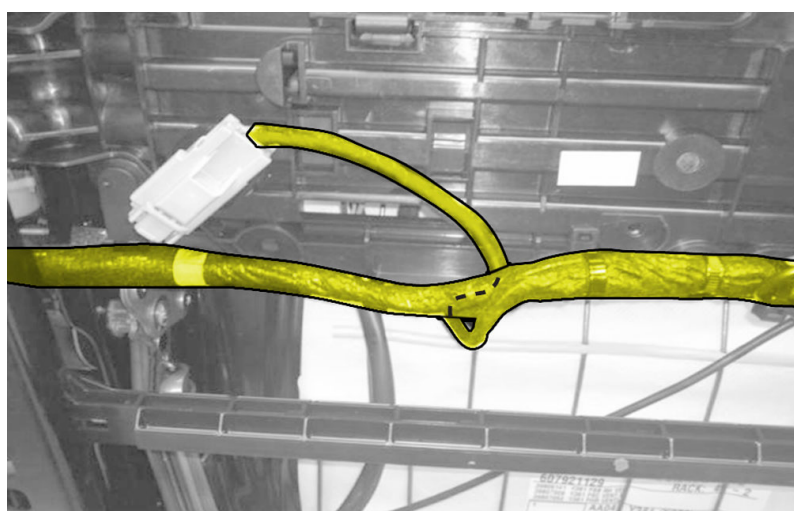

Note! Vehicles with Seat Ventilation

Vehicles with power seats

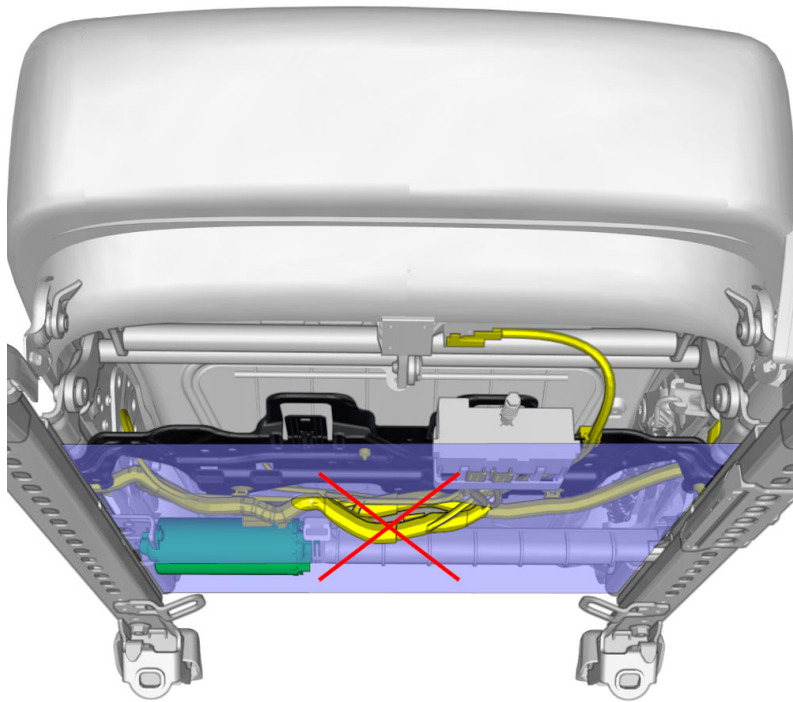

Caution! Make sure that the wiring harness does not catch.

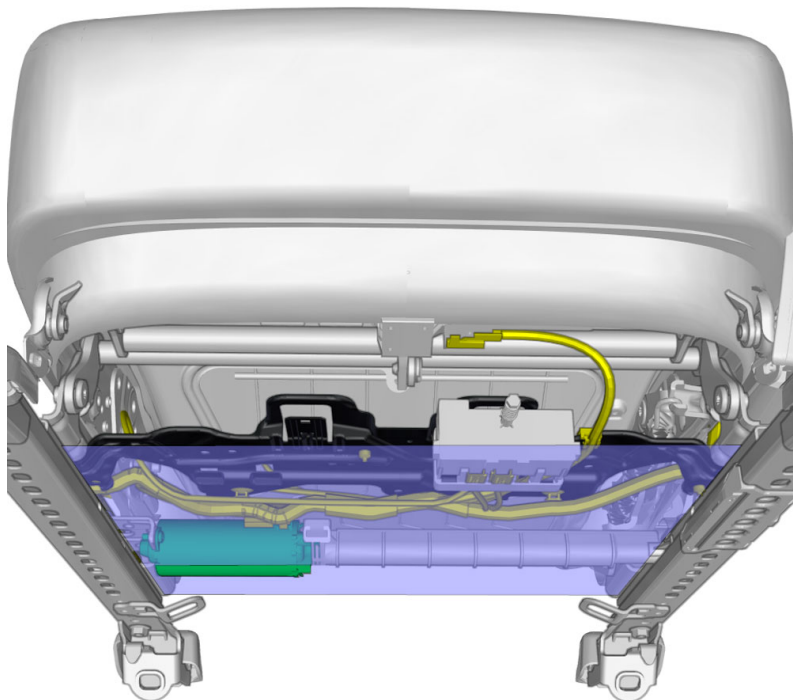

Note! Extra cable length must be secured using cable ties.

Vehicles without power seats

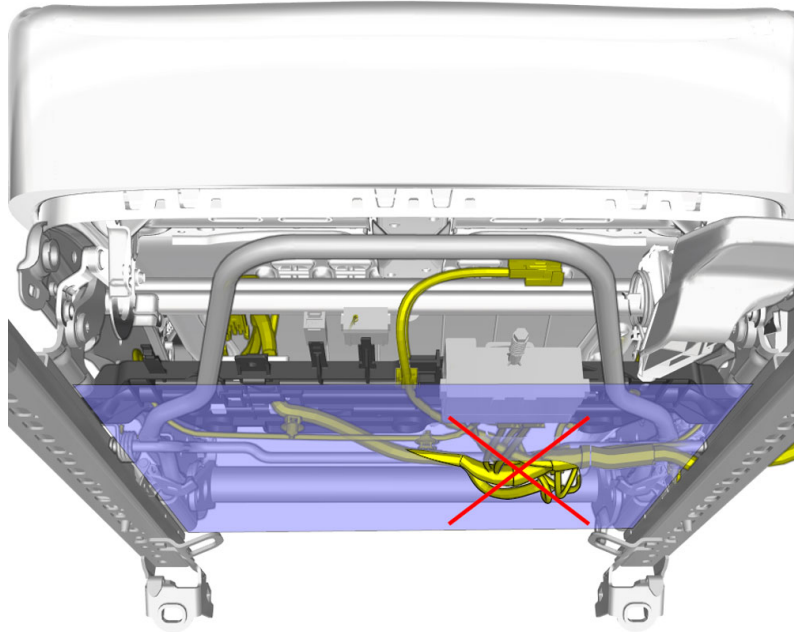

Caution! Make sure that the wiring harness does not catch.

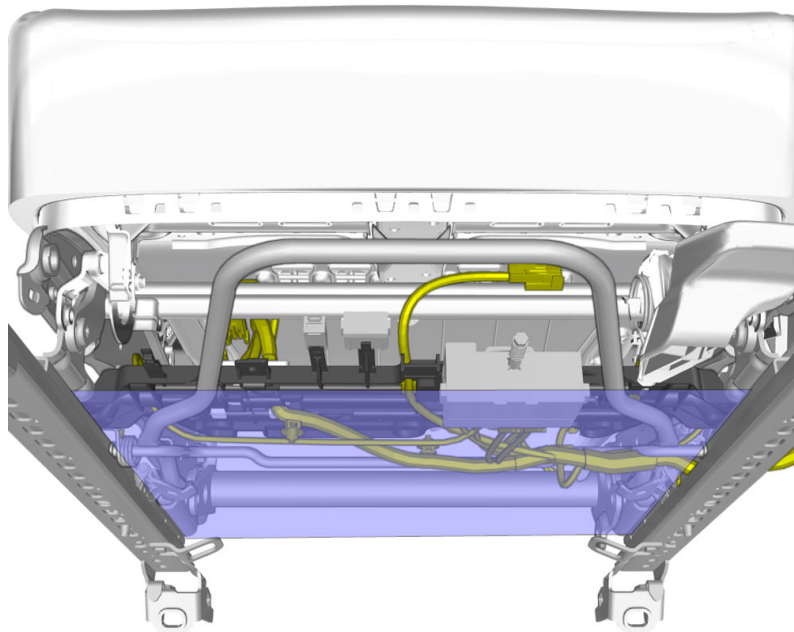

Note! Extra cable length must be secured using cable ties.

Check

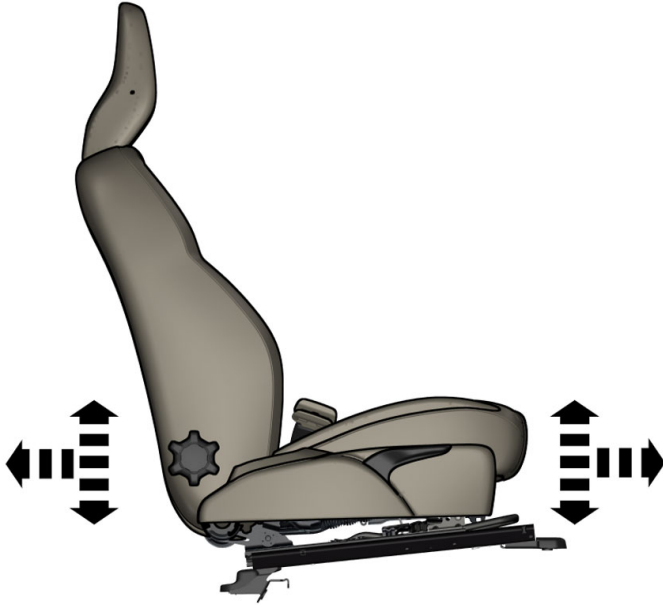

Caution! Make sure to reach all end positions.

Caution! Make sure that the wiring harness is not stretched.

Install the front seat, refer to:

Removal, replacement and installation

8 - Body and interior

85 - Interior

852 - front seat, drivers seat, seat bench type