

IMPORTANT INFORMATION

Please inform and provide a copy of this document to every person in your dealership with campaign-related responsibilities, including Service, Parts and Accounting personnel. By law, dealers must correct, prior to delivery for sale or lease, any vehicle that fails to comply with an applicable Federal Motor Vehicle Safety Standard or that contains a defect relating to motor vehicle safety. If you have questions regarding this or any other campaign, please contact Warranty



Audi

Safety Recall

Subject: Model Year 2012 Audi A6
Sideguard® Head Curtain Airbag

Code: 69I5

UNITED STATES ONLY

December 8, 2011

Problem Description

Due to a production problem in the stitching process of the Sideguard® head curtain airbag cushion on one production day, the seam of the airbag may not be stitched properly. Because of this, the head curtain airbag may not deploy in a crash, increasing the risk of injury to vehicle occupants. Audi is not aware of any case with an injury or death caused by this issue.

Corrective Action

Dealers will replace the left and/or right Sideguard® head curtain airbag.

VIN Ranges & Production Dates

NOTE:

- *ElsaWeb is the only valid campaign inquiry/verification source. Check ElsaWeb on the day the campaign work will be performed to verify vehicle eligibility for the repair in order to receive claim payment consideration. Campaign status must show "open".*
- *If this repair appears to have already been performed on the vehicle but the code still shows open in ElsaWeb, contact Warranty before proceeding further. Another dealer may have recently performed this repair but not yet entered a claim for it in the system.*
- *ElsaWeb may also show additional open action(s); if so, inform your customer - this work can be done while the vehicle is in for this campaign.*
- *Contact Warranty if you have any questions.*

2012 Audi A6

WAU__FC_CN003355 - WAU__FC_CN004425

Production dates: April 8, 2011 – May 26, 2011

NOTE: The VIN range is a general range of vehicles that may be included in the Campaign. Not every vehicle within the VIN range may be included since it may depend on the production date, transmission or engine build date. Always verify ElsaWeb for campaign eligibility on a vehicle.

Allocation Report of Affected Vehicles

- Late last week, Audi contacted all dealers with affected inventory via telephone to confirm that the affected vehicle(s) are at the dealership, and to place Warranty Red Orders for the required replacement parts. A confirmation email for the parts order was sent to the Parts Manager at each affected dealership. Please contact your Parts Manager to find out if the replacement parts have arrived at your dealership.

- On December 8, 2011, the affected inventory vehicles will appear on dealer AIM reports with the recall code **69I5**. Dealers should check their AIM report to see if they have any in-stock vehicles affected by this recall and **mandatory stop sale**.
- Please keep any affected vehicle in a secure area where it cannot be made available for sale, lease, trade or demo use until the recall repair has been performed.

Parts Information and Allocation

- While at this time parts are only being allocated to dealers with inventory units affected by this recall, Audi is working diligently to procure parts for the affected customer vehicles. We expect these additional parts to become available in January 2012.
- In the interim, if any customer indicates that they are concerned about driving their vehicle before the campaign repair has been made, dealers are asked to arrange alternate transportation (i.e.: loaner vehicles) for the customer, and give priority to the vehicle repair once parts become available. Contact Warranty to verify vehicle eligibility for this recall.

Owner Notification Mailing

Depending on parts availability, customer notification is anticipated to take place in January 2012.

Mandatory Stop-Sale

There is a mandatory stop-sale order on inventory vehicles affected by this recall.

- If you have an affected vehicle, **DO NOT** sell, lease, or dealer trade it until the repair has been completed. If you are using an affected vehicle as a demo, discontinue doing so immediately until this recall repair has been completed.
- Please keep any affected vehicle in a secure area where it cannot be made available for sale, lease or trade until the repair has been completed.

Important Reminder on Vehicles Affected by Safety and Compliance Recalls

By law, dealers must correct, prior to delivery for sale or lease, any vehicle that fails to comply with an applicable Federal Motor Vehicle Safety Standard or that contains a defect relating to motor vehicle safety.

Claim Entry Procedure

Immediately upon completion of the repair work, enter the Applicable Criteria ID and Repair Operation from the following chart. **The Applicable Criteria ID is shown in ElsaWeb.** Claims will only be paid for vehicles that show this campaign open in ElsaWeb on the day of the repair. To help ensure prompt and proper payment, attach the screen print to the repair order.

Saga Claim Entry Procedure

Check ElsaWeb to determine whether the “69I5” campaign is open.

Service No.: 69I5

Damage Code: 0099

Parts Manufacturer

Removed part: Use vendor code **002.**

Sold vehicle = 7 10

Unsold vehicle = 7 90

Accounting Instructions

Criteria I.D LS

Remove and Install Headliner

Repair operation: 7084 19 99 220 T.U.

Replace left Sideguard® head curtain airbag

Repair operation: 6966 19 99 30 T.U.

<u>Quantity</u>	<u>Part Number</u>	<u>Part Description</u>
1	4G5 880 741C	Left Sideguard® head curtain airbag
1	N 911 202 02	Bolt (M5x20)
4	8Z0 867 276	Clamp

OR

Criteria I.D. RS

Remove and Install Headliner

Repair operation: 7084 19 99 220 T.U.

Replace right Sideguard® head curtain airbag

Repair operation: 6966 20 99 30 T.U.

<u>Quantity</u>	<u>Part Number</u>	<u>Part Description</u>
1	4G5 880 742C	Right Sideguard® head curtain airbag
1	N 911 202 02	Bolt (M5x20)
4	8Z0 867 276	Clamp

OR

Criteria I.Ds LS and RS

Remove and Install Headliner

Repair operation: 7084 19 99 220 T.U.Replace left Sideguard[®] head curtain airbag**Repair operation:** 6966 19 99 30 T.U.Replace right Sideguard[®] head curtain airbag**Repair operation:** 6966 20 99 30 T.U.

<u>Quantity</u>	<u>Part Number</u>	<u>Part Description</u>
1	4G5 880 741C	Left Sideguard [®] head curtain airbag
1	4G5 880 742C	Right Sideguard [®] head curtain airbag
4	8Z0 867 276	Clamp
2	N 911 202 02	Bolt (M5x20)

There is NO reimbursement for Vehicle Wash or Loaner

If customer refused repairs

Fax the Repair Order to the warranty team at (248) 754-6533. Provide the VIN, applicable Service Number, Customer information, Dealer number and date.

If there are questions regarding the work procedure, contact Warranty

Required Parts:

<u>Quantity</u>	<u>Part Number</u>	<u>Part Description</u>
1	4G5 880 741C	Left Sideguard [®] head curtain airbag (if applicable)
1	4G5 880 742C	Right Sideguard [®] head curtain airbag (if applicable)
4	8Z0 867 276	Clamp
Up to 2	N 911 202 02	Bolt (M5x20)

Required Tools:



- T40207 – Hook



- T10039 – Release lever (or equivalent)

The information in this document is intended for use only by skilled technicians who have the proper tools, equipment and training to correctly and safely maintain your vehicle. These procedures are not intended to be attempted by "do-it-yourselfers," and you should not assume this document applies to your vehicle, or that your vehicle has the condition described. To determine whether this information applies, contact an authorized Audi dealer. ©2011 Audi of America LLC. All Rights Reserved.

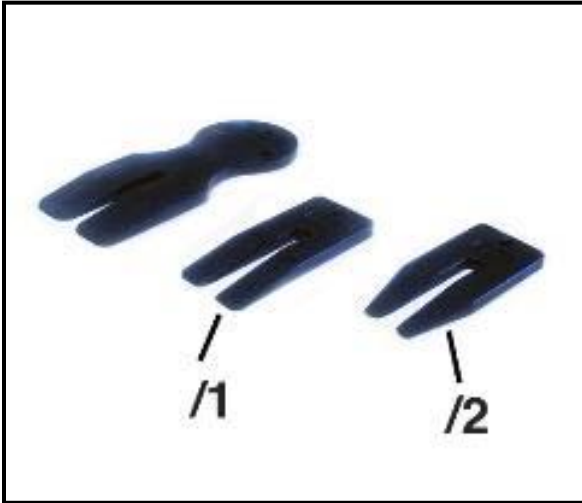

- T10383 – Wedges (or equivalent)



- 80-200 – Pry lever (or equivalent)



- 3409 – Trim removal wedge (or equivalent)

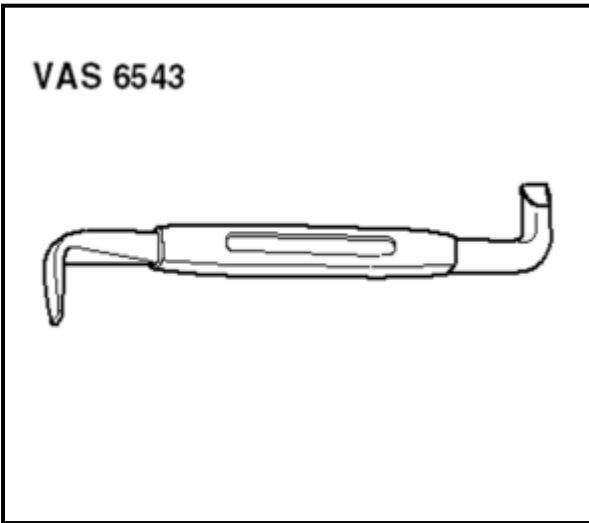



- VAS 6543 – Long Reach Special Wrench for Slotted Bolts (or equivalent)

Work Procedure:

 **Caution:** Handle head curtain airbag modules with great care when removing and installing them to prevent causing any damage. Never rotate, coil, knot, throw, slide, push, hand, squeeze, press, pinch or clamp head curtain airbag module.

Applicable Criteria ID (s)	Campaign/Action Status
03	Open

EXAMPLE

Section A – Ensure Campaign Eligibility

- Enter the VIN in ElsaWeb and proceed to the “Campaign/Action” screen

 **Tip:** On the date of repair, print this screen and keep a copy with the repair order

- ⇐ Ensure that the Status is “Open” <arrow 2>
- ⇐ Note the Applicable Criteria ID(s) <arrow 1> for use in determining the correct work to be done and corresponding parts associated

The information in this document is intended for use only by skilled technicians who have the proper tools, equipment and training to correctly and safely maintain your vehicle. These procedures are not intended to be attempted by “do-it-yourselfers,” and you should not assume this document applies to your vehicle, or that your vehicle has the condition described. To determine whether this information applies, contact an authorized Audi dealer. ©2011 Audi of America LLC. All Rights Reserved.

Section B – Disconnect Battery



Caution: Accident risk. When working on pyrotechnic components (such as airbags and belt tensioners), the battery must be disconnected with the ignition switched ON



Note: Damage to electrical/electronic components or erroneous DTC's may result if the battery is disconnected with ignition off

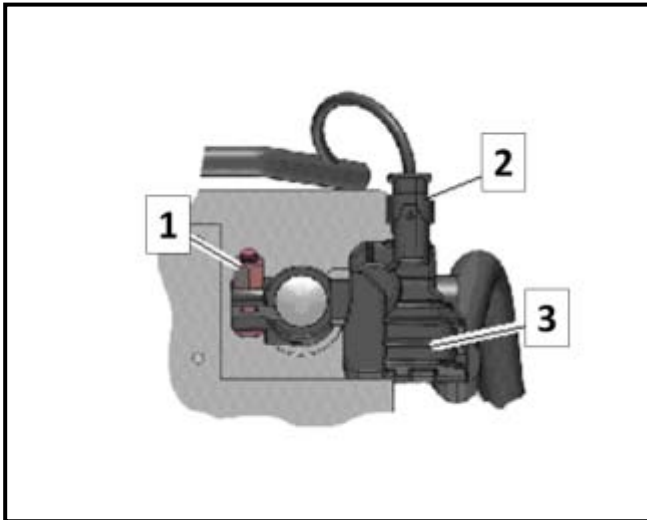

- If equipped, open the sunroof
 - Ensure ignition remains switched ON
 - Tilt front seats backward 45°
 - Close all doors and windows other than sunroof
 - Open trunk
 - Lift luggage compartment floor covering by the handle and fold it forward
 - Remove spare wheel
 - Remove luggage compartment tool kit
 - Open the cover over the battery negative terminal
- ⇐ Loosen the nut <1> several turns and remove the ground wire terminal clamp from the battery terminal

Section C – Trim removal



Note: In cold conditions, allow trim to warm to room temperature prior to working with trim as damage may result if trim is removed when too cold.

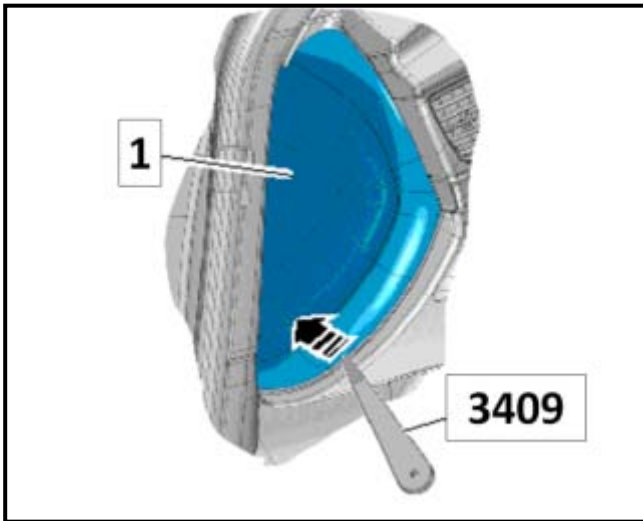

⇐ Pry the instrument panel side cover <1> off using the trim removal wedge 3409 (or equivalent) <arrow> and remove it

- Repeat on opposite side of vehicle

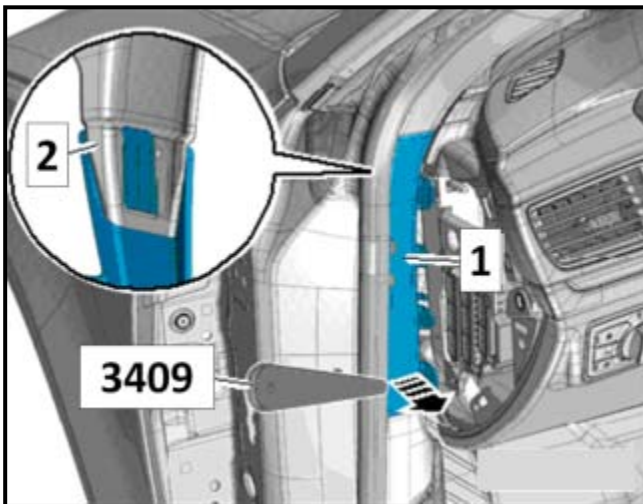

⇐ Unclip the lower gap cover <1> from the A-pillar using trim removal wedge 3409 <arrow> and remove it from the A-pillar trim <2> downward

- Repeat on opposite side of vehicle

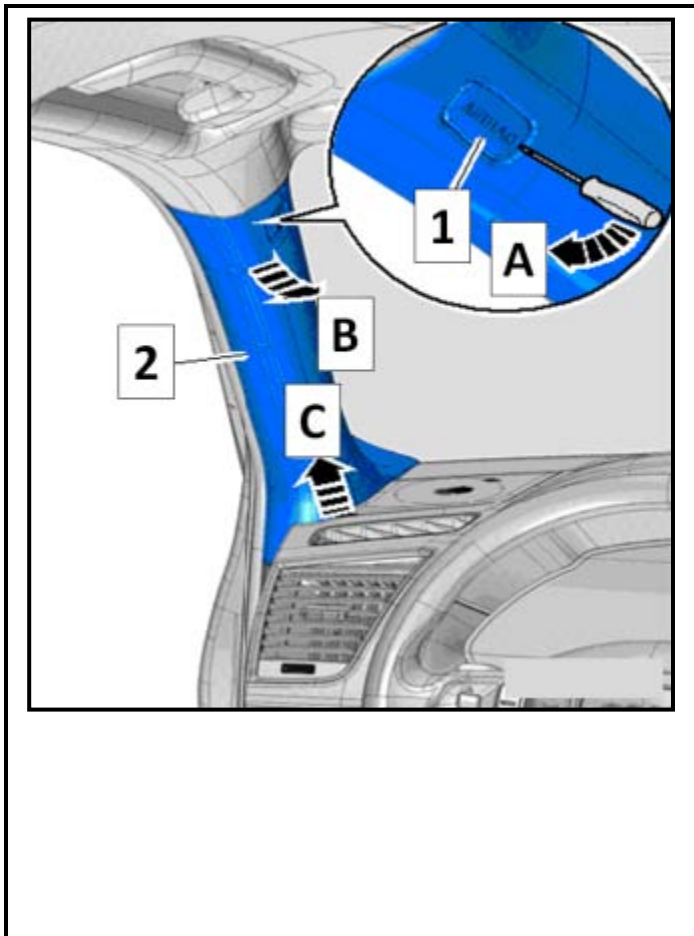

⇐ Pry out the expanding cap <1> with the “AIRBAG” symbol about 4mm with a screwdriver <arrow A>

⚠ Note: Two clamps in the A-pillar trim contain hooks (barbs) and can only be detached up to their first catch. These clamps will not come out with the trim.

⇐ Carefully unclip the upper A-pillar trim <2> up to the first catch of the clamps beginning at the top using a pry lever 80-200 (or equivalent) <arrow B>

⇐ Pull the trim upward <arrow C> to disengage the trim from the clamps

ℹ Tip: The trim will slide off of the clamps as you pull trim upward

- Pull the upper A-pillar trim out of the instrument panel and remove it
- Repeat on opposite side of vehicle



- Remove and discard clamps <circles>

⚠ Note: These clamps <circles> MUST NOT be reused



Tip: Front Belt Anchor does NOT need to be removed

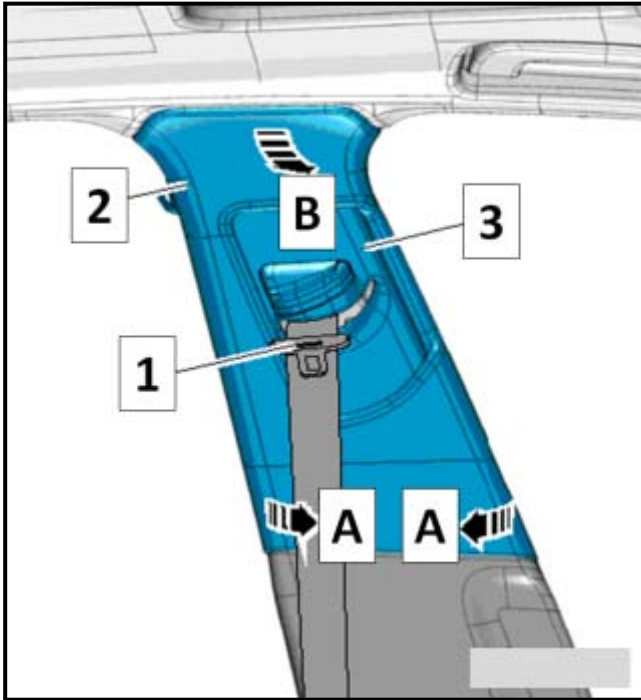

- ⇐ Move seat belt height adjuster <3> to its lowest position
- ⇐ Position the trim removal wedge 3409 (or equivalent) at the bottom edge of the upper B-pillar trim <2> and unclip the trim <in direction of arrows A> by sliding trim downward slightly to disengage it from the B-pillar
- Vehicle with a vent: disconnect the electrical connector on rear of B-pillar trim
- Lower the upper B-pillar trim and set trim to the side with seat belt still attached
- Repeat on opposite side of vehicle



- ⇐ On rear seats, press the release button <arrow 1> using a small screwdriver, then press the release button <arrow 2>
- At the same time lift the head restraint out of the seat
- Repeat for all rear head restraints

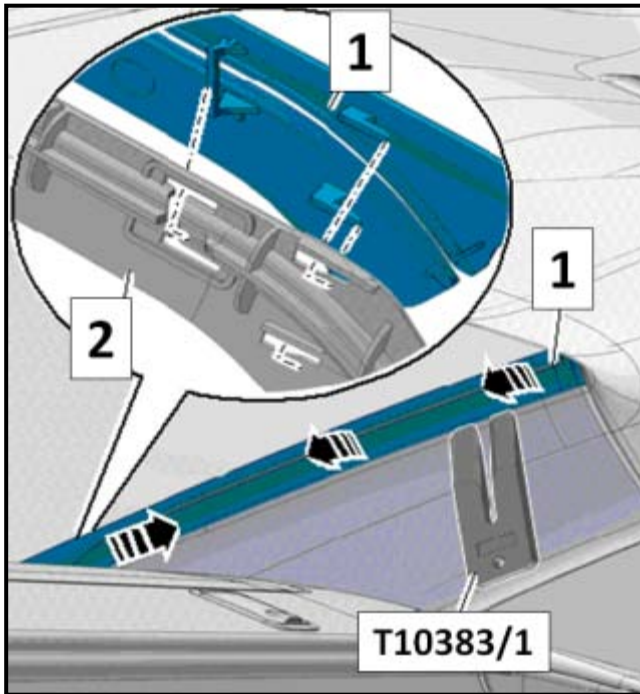

- ⇐ If equipped with rear window shade: starting at the top, use the wedge T10383/1 (or equivalent) to unclip the trim panel <1> for the rear window shade guide strip <arrows>
- ⇐ Pull the lower part of the trim upward and out of the rear window shade guide strip <2>; then remove it from the inside
- Repeat on opposite side

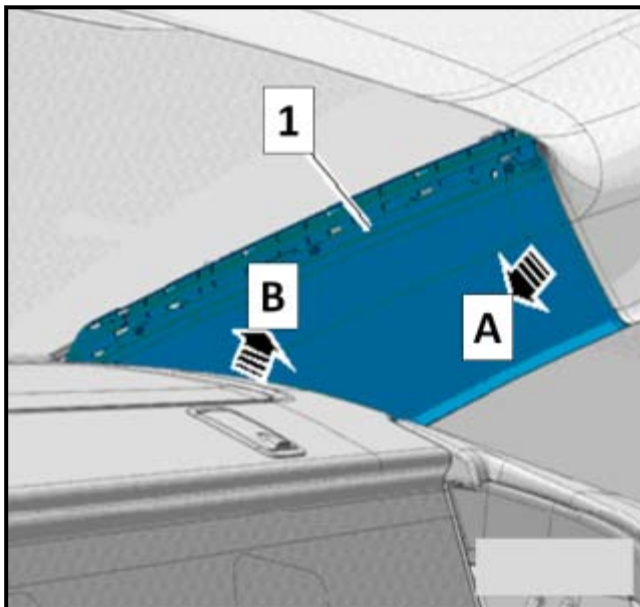

- ⇐ Unclip the rear D-pillar trim <1> using the T10383/1 trim removal wedge (or equivalent) <arrow A>
- ⇐ Pull the rear D-pillar trim upward from the rear shelf <arrow B> and remove
- Repeat on opposite side



⚠ Note: The C-pillar trim shown left <arrow> does NOT need to be removed as headliner can be lifted over the trim

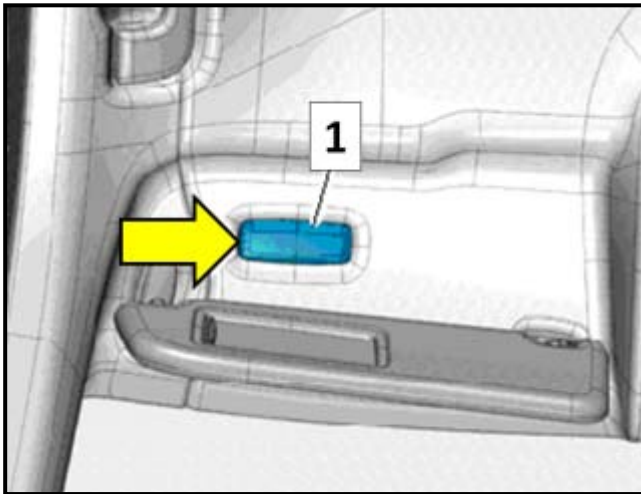

⇐ Pry out the vanity mirror illumination <1> at the cut-out <arrow > using a flat-blade screwdriver

- Disconnect the connector
- Repeat on opposite side

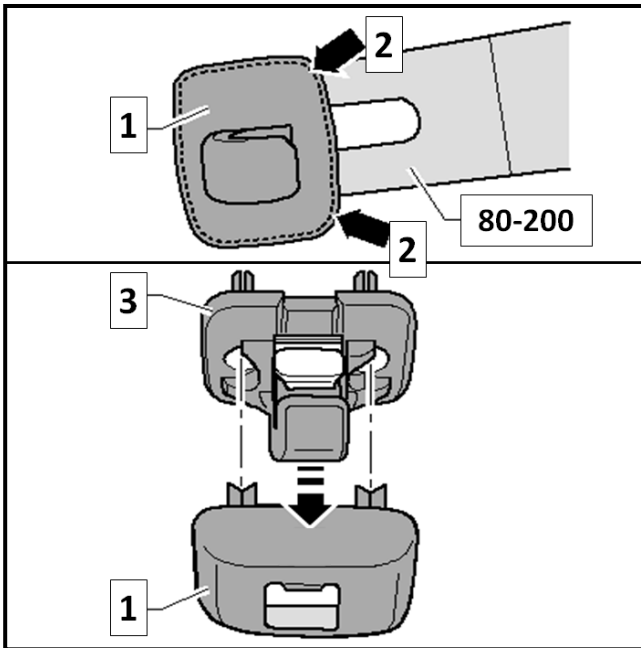

⇐ Unclip the sun visor center bracket cover <1> by sliding the pry lever 80-200 (or equivalent) only approximately 1mm under the cap <arrows 2>

ⓘ Tip: If pry lever 80-200 is shoved too far underneath, it will become lodged under the center bearing for the sun visor. At that point, it is not possible to pry off the cover

- ⇐ Remove the sun visor center mount <3>
- Repeat on opposite side

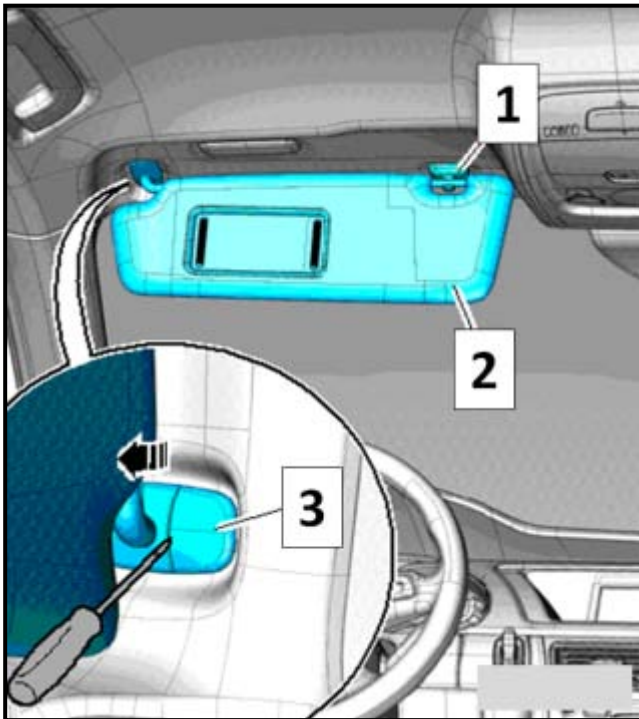

- ⇐ Unclip the expanding cap <3> using a screwdriver
- ⇐ Remove the sun visor mount downward <arrow> out of the opening in the body
- Disconnect the electrical connector and remove the sun visor
- Repeat on opposite side

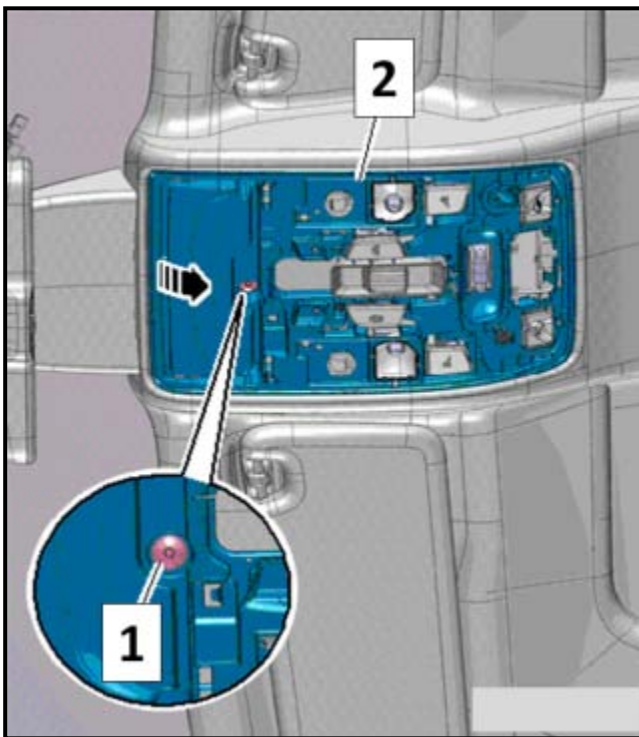

- If equipped, open the eyeglass compartment
- ⇐ Remove bolt <1>
- ⇐ Move the interior lamp/reading lamp <2> forward and down <arrow> and disengage it
- Disconnect electrical connectors

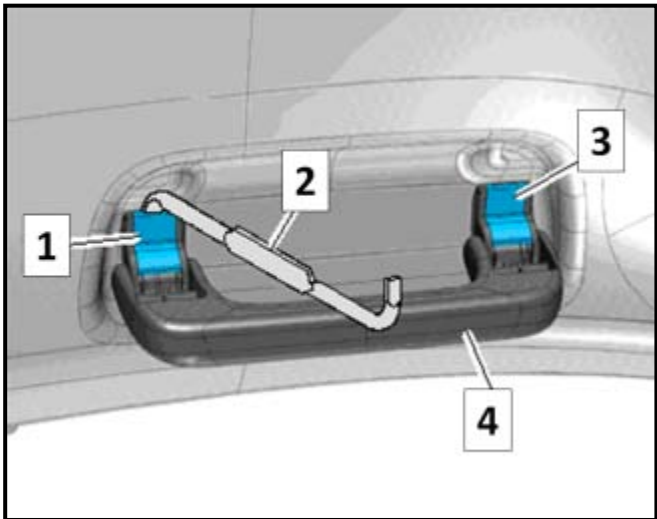

! Note: Unclip the expanding caps <1> and <3> only up to their first initial lock position. DO NOT pull them all the way out as this will damage the grab handle

- ⇐ Unclip expanding caps <1> and <3> slightly to their first locking position using VAS 6543 (or equivalent offset screwdriver) <2>
- ⇐ Remove the roof grab handle <4> from the body opening
- Repeat on remaining grab handles

Section D – Headliner Lowering

Vehicles equipped with sunroof:

- Ensure sunroof is open all the way

i Tip: Clean the release lever T10039 (or equivalent) to prevent getting dirt on the headliner

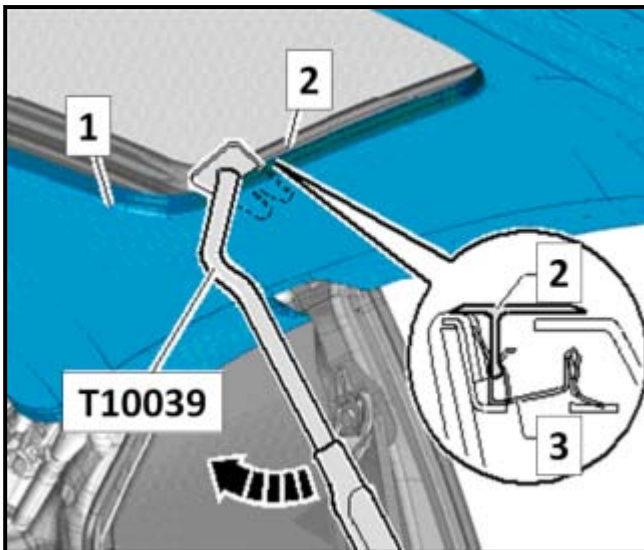

i Tip: If not using the T10039, it may necessary to cover the tool used with electrical tape to prevent scratching sunroof frame and/or damaging the headliner

- ⇐ Slide the release lever T10039 (or equivalent) between the cover frame <2> for the sunroof opening and the headliner <1> until it touches one of the clips <3>
- ⇐ Open the clips, one after the other, using the release lever T10039 (or equivalent) as illustrated <arrow>



 Tip: Picture on left shows location of 16 headliner clips <arrows> around sunroof frame

All vehicles:

 Note: Be very careful when working with and lowering the headliner as the headliner bends very easily

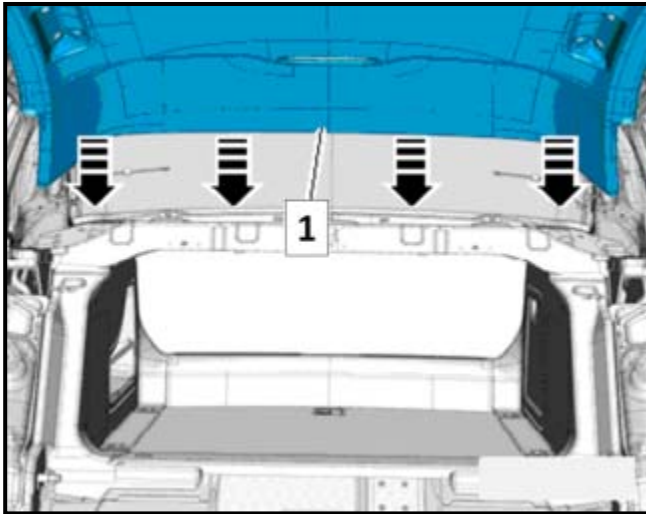

- ⇐ Separate the rear section of the headliner <1> from the body using the release lever 80-200 (or equivalent) <arrows>
- Open the tabs with a screwdriver and unclip the rear section of the headliner from the body at the centering pin



- ⇐ Lift the headliner carefully over the remaining C-pillar trim <arrow>



! Note: Two technicians are needed to disconnect the last connections on the headliner. Be very careful when lowering the headliner as it bends easily

⇐ Carefully lower the headliner <as shown>, bracing and supporting where necessary to prevent damage

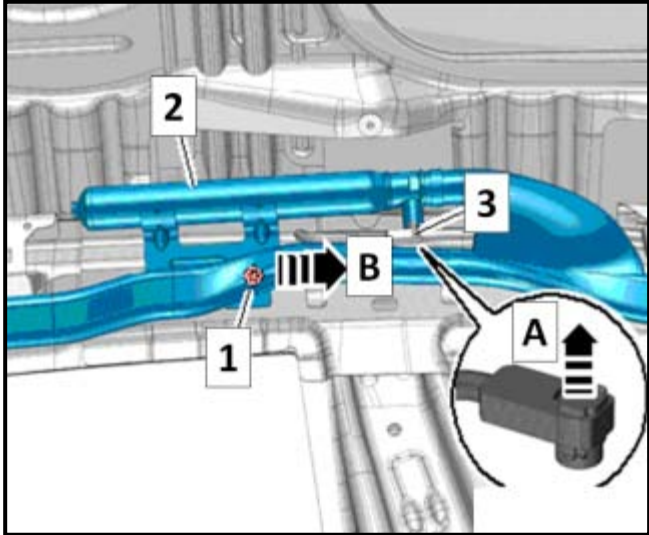

Section E – Head Curtain Airbag with Igniter N251/N252 Replacing

- Perform the following work procedure on Left Side (LS) and/or Right Side (RS) depending on Applicable Criteria ID found in the Campaigns/Actions tab in ElsaWeb (see Section A)

⇐ Release the connector lock <arrow A> using a small screwdriver and disconnect the connector <3>

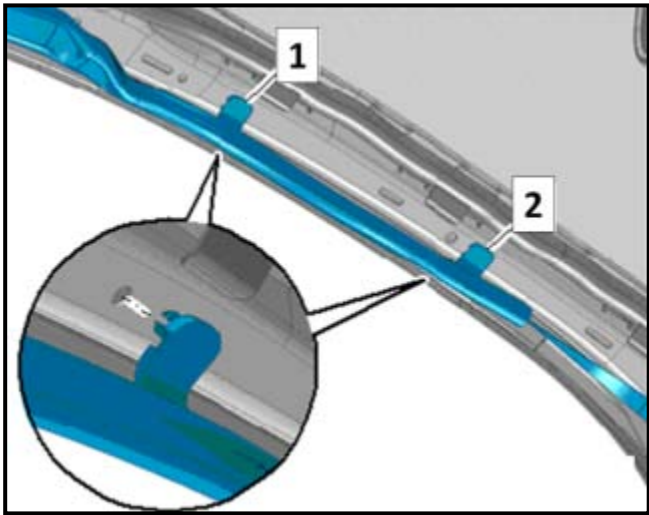

⇐ Remove the clips <1> and <2> from the A-pillar

The information in this document is intended for use only by skilled technicians who have the proper tools, equipment and training to correctly and safely maintain your vehicle. These procedures are not intended to be attempted by "do-it-yourselfers," and you should not assume this document applies to your vehicle, or that your vehicle has the condition described. To determine whether this information applies, contact an authorized Audi dealer. ©2011 Audi of America LLC. All Rights Reserved.

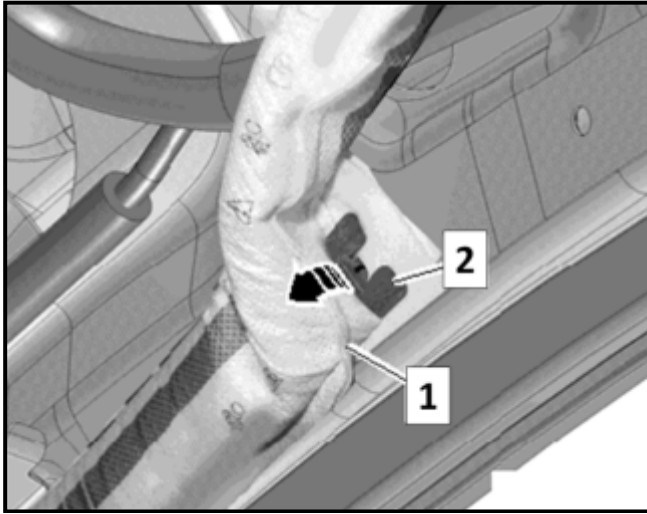

⇐ Carefully disengage the head curtain airbag <1> from each of the clips <2> <arrow>

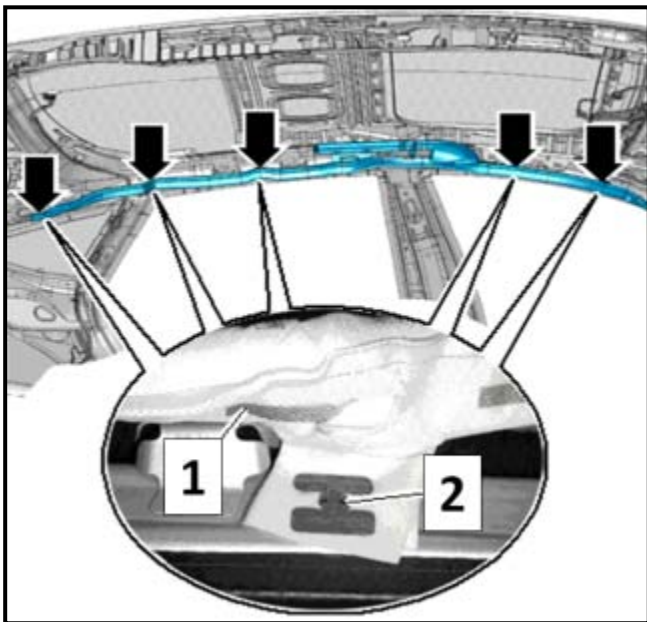

⇐ Remove the clips <arrows> from the head curtain airbag <1> with pliers

⚠ Note: The clips <2> will become damaged during the removal



 Tip: Pry off clips using side cutters. DO NOT cut the clips off as the pieces will remain in the roof member and cause rattling/noise issues

 Warning: Before handling pyrotechnical components (for example, disconnecting the connector), the person handling them must “discharge static electricity”. For example, by briefly touching the door striker pin

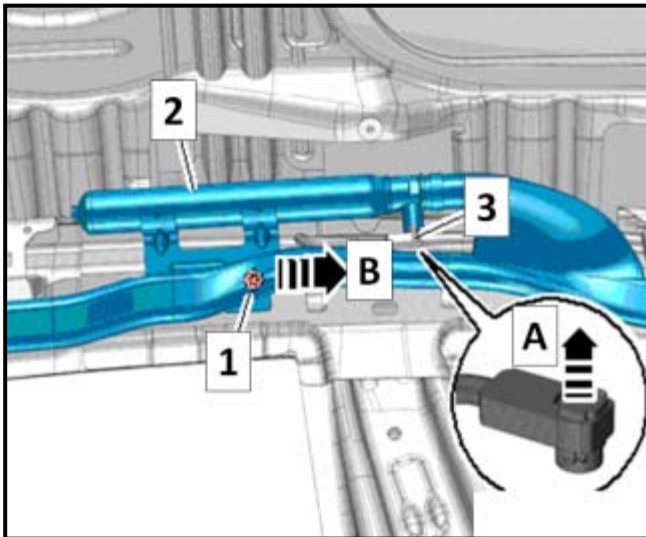

- ⇐ Remove and discard the bolt <1> from the gas generator
- ⇐ Push the head curtain airbag <2> forward <arrow B> and remove it from the mount

The information in this document is intended for use only by skilled technicians who have the proper tools, equipment and training to correctly and safely maintain your vehicle. These procedures are not intended to be attempted by “do-it-yourselfers,” and you should not assume this document applies to your vehicle, or that your vehicle has the condition described. To determine whether this information applies, contact an authorized Audi dealer. ©2011 Audi of America LLC. All Rights Reserved.

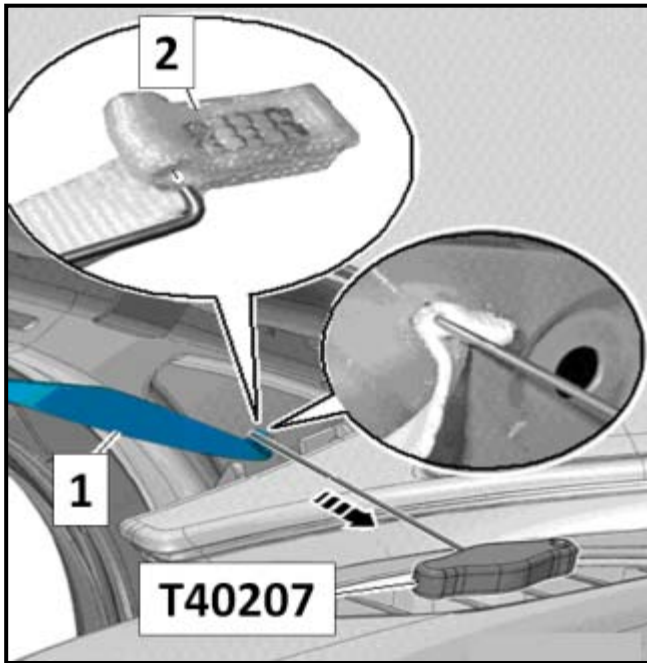

i Tip: The removal of the limiting strap is best done with airbag removed so that as much slack as possible is available on the strap

- ⇐ Remove the head curtain airbag limiting strap <1> from the A-pillar
- ⇐ Carefully position the hook T40207 (or equivalent) and then guide it into the opening in the body
- ⇐ Attach the hook T40207 to the loop <2> on the head curtain airbag limiting strap and carefully pull it straight out <arrow>
- Set airbag safely to the side

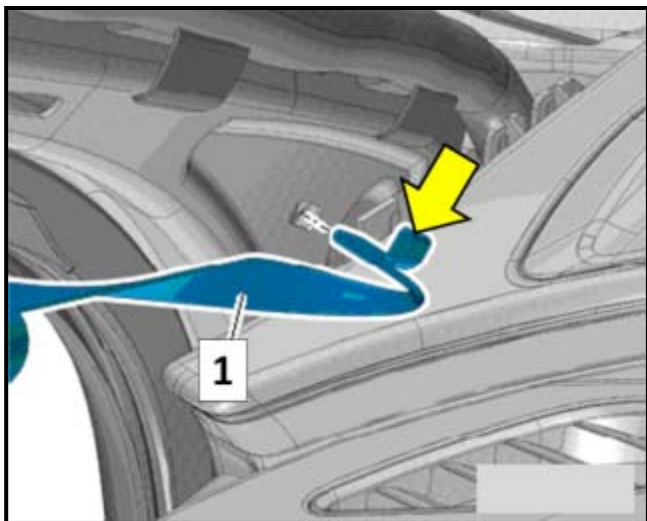

- ⇐ Obtain new head airbag(s) based on Applicable Criteria ID requirements as follows:
 - Criteria LS = Driver side – 4G5 880 741C
 - Criteria RS = Passenger side – 4G5 880 742C

i Tip: The installation of the limiting strap is best done before new airbag is installed so that as much slack as possible is available on the strap

- ⇐ Attach the head curtain airbag limiting strap <1> to the A-pillar with the loop <arrow> facing upward

! Note: The loop <arrow> must face upward

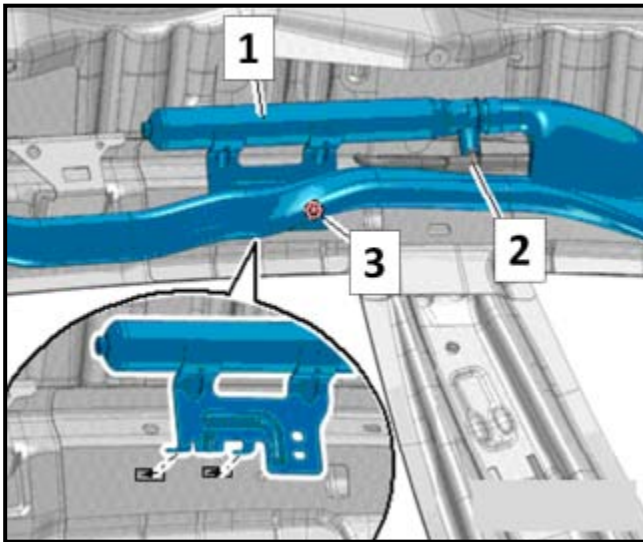

⇐ Attach the gas generator <1> to the body <arrows>

⇐ Install new screw part number (N 911 202 02) and tighten the bolt <3> to 5Nm

⇐ Connect the connector <2> to the head curtain airbag igniter

- Press in the connector lock

 Tip: Pressing in the connector lock slides the connector into the head curtain airbag igniter as far as its stop position and simultaneously locks it in place

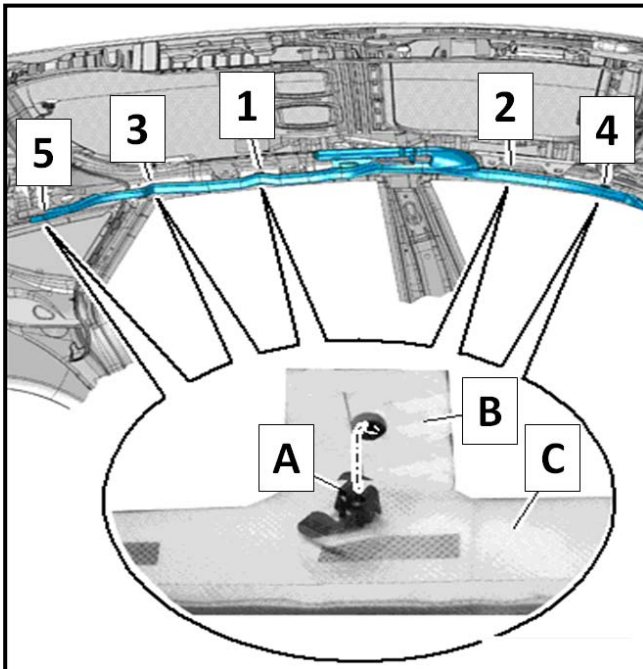

⇐ Insert the clip <A> carefully into the head curtain airbag <C>, then attach tab to the clip <A>

⇐ Install the clips for the head curtain airbag in sequence <1,2,3,4,5> and ensure that each clip engages audibly into the body

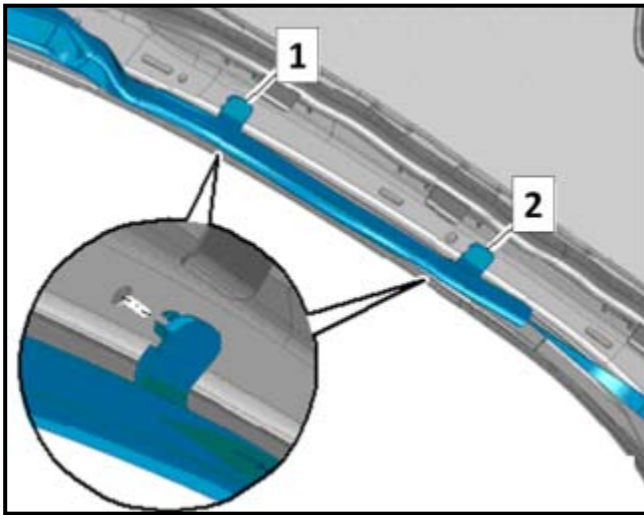

⇐ Install the clips <1> and <2> in the A-pillar and ensure that the “black line” is visible the entire length



 **Warning:** It is necessary that the “black line” <circle> be visible the entire length. By making sure it is visible the entire length will ensure that the head curtain airbag is NOT twisted

 **Note:** Repeat this Section of the work procedure for other side as necessary based on Applicable Criteria ID(s) found in ElsaWeb under the Campaigns/Actions tab.

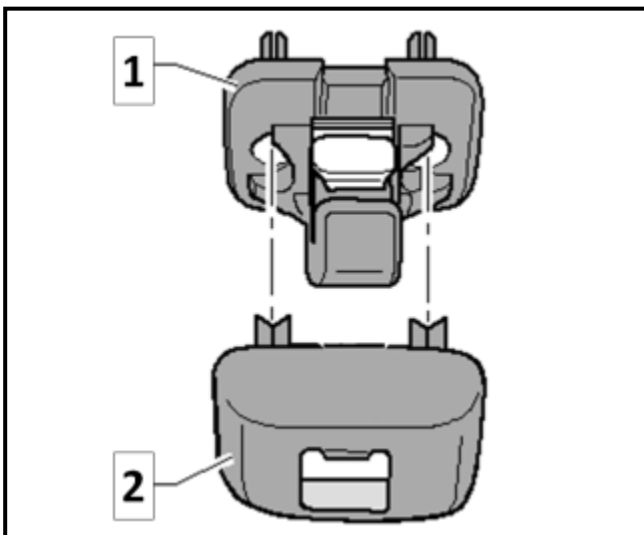

Section F – Headliner Reinstallation

 **Tip:** For convenience, it is o.k. to jump ahead to Section G to reconnect the battery and check for DTC's. If doing so however, perform Section B to disconnect the battery before continuing with work procedure Section F.

⇐ Align headliner, press in retaining clip at the back of the headliner until it engages audibly in the mounting point of the body

⇐ Reinstall both center supports for the sun visors <1> and cover <2> to hold headliner in place



⇐ Lift the headliner over the C-pillar trim <arrow>

- Repeat on opposite side



 Tip: Picture on left shows location of 16 headliner clips <arrows> around sunroof frame

⇐ Reattach clips <arrows> to sunroof frame until they snap into place



- Reinstall the roof grab handle into the body opening and clip the expanding caps <arrow 1> and <arrow 2> properly back into position

- Repeat on remaining grab handles

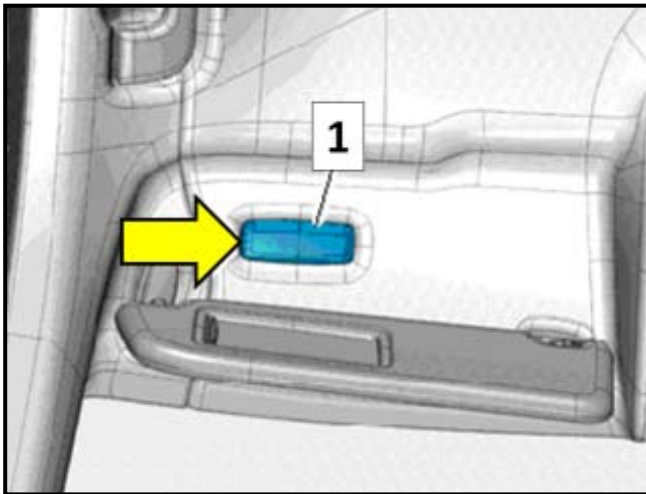

⇐ Reconnect electrical connector for the vanity mirror illumination <1> and clip properly into position

- Repeat on opposite side

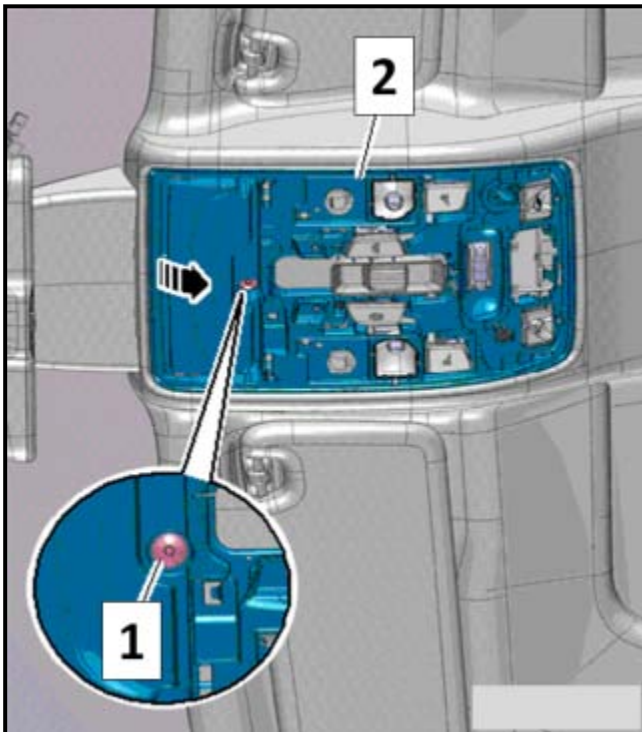

⇐ Place the interior lamp/reading lamp <2> into position and reconnect electrical connectors

⇐ Reinstall bolt <1> and torque to 2Nm

- If equipped, close the eyeglass compartment

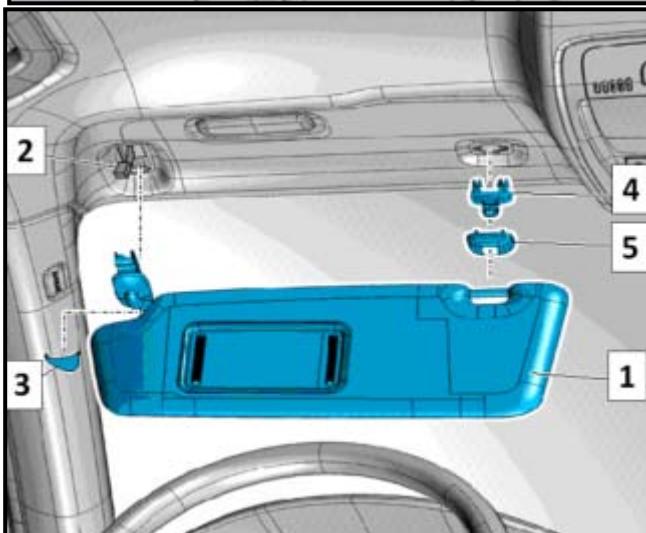

⇐ Reconnect the electrical connector <2> for the sun visor <1>

⇐ Reinstall the sun visor <1> into the mount

⇐ Reinstall the expanding cap <3>

- Repeat on opposite side

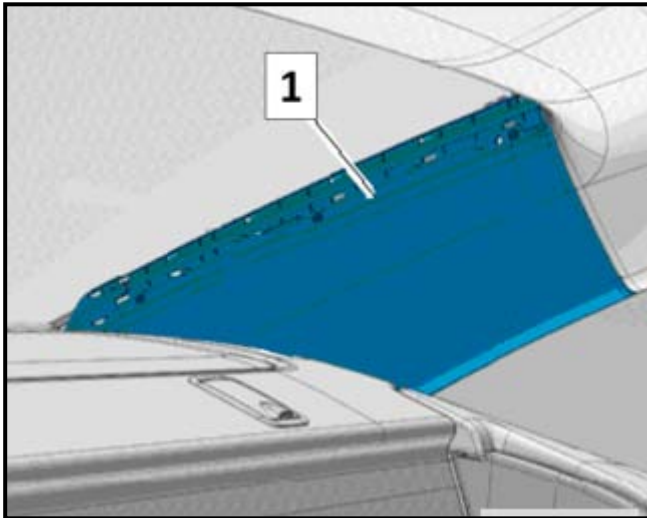

⇐ Reinstall the D-pillar trim <1> and ensure clips engage properly in place

- Repeat on opposite side

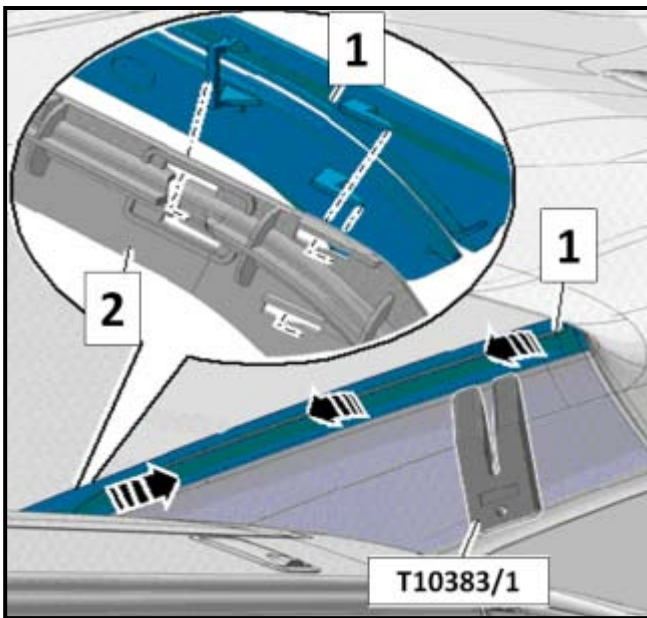

⇐ If equipped with rear window shade: reinstall the trim panel <1> for the rear window shade guide strip and ensure clips properly engage

- Repeat on opposite side
- Reinstall the rear headrests

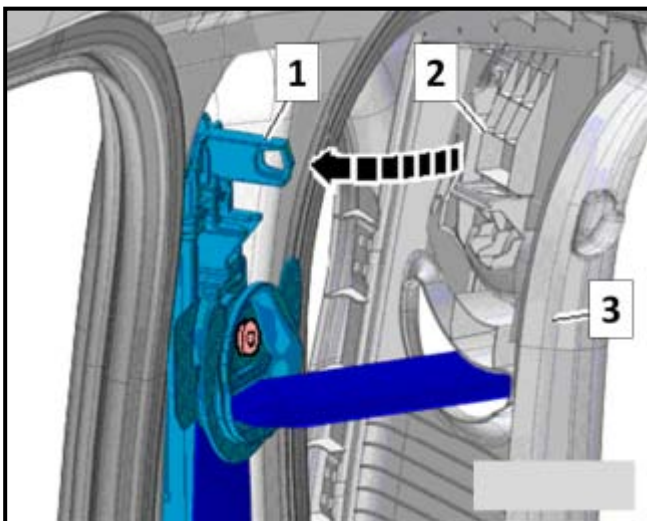

⚠ Note: Ensure that the seat belt height adjuster is in the lowest position

⇐ Insert the B-pillar trim <3> upward into the mount on the roof

⇐ Reengage the mount <2> for the sliding piece of the B-pillar upper trim onto the retaining pin <1> on the seat belt height adjuster <arrow>

- Repeat on opposite side

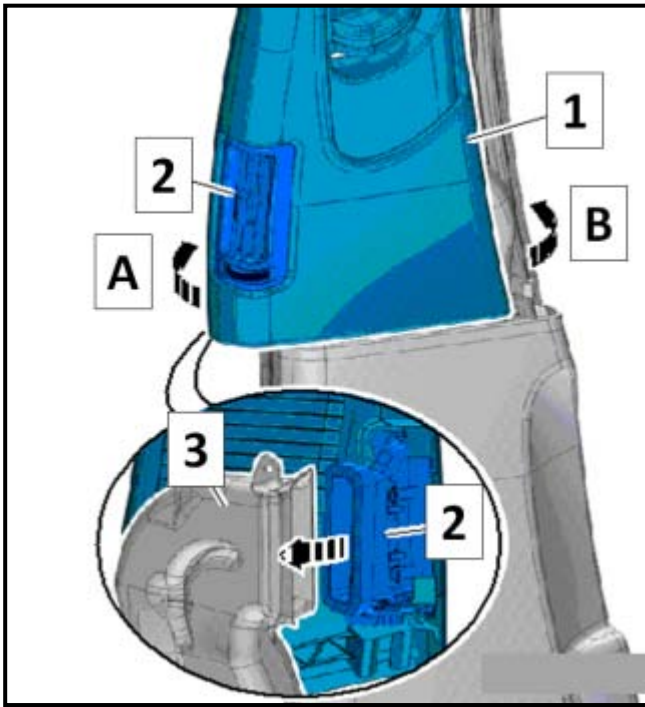

Versions with a vent:

- ⇐ Reposition the B-pillar rear trim <1> on the B-pillar so that the vent <2> locks into the air duct <3> <arrow>
- ⇐ Lock the B-pillar rear trim in the B-pillar <arrow A>
- ⇐ Reinstall the B-pillar front trim in the B-pillar <arrow B>
- Stretch the door seal lips over the trim
- Repeat on opposite side

All vehicles:



Warning: When A-pillar trim is being reinstalled it is necessary to remove the old clips from the body and use two new clips <arrows> part number (8Z0 867 276) and mount them in the trim prior to installing the trim onto the body. Doing so ensures that trim does not become loose in the event of head airbag deployment and injure the occupant(s).



- ⇐ Insert two new clamps <arrows> part number (8Z0 867 276) into each A-pillar trim piece

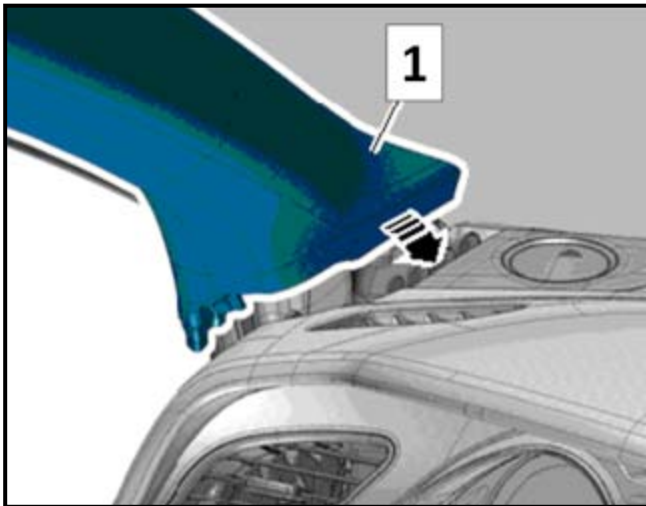

⇐ Reinsert the upper A-pillar trim <1> in the mount of the instrument panel <arrow>

- Clip the upper A-pillar trim in so that all three clips are seated properly and firmly into position
- Stretch the door seal lip over the trim
- Repeat on opposite side



⇐ Reinsert the expanding cap <arrow> with the "AIRBAG" symbol

- Repeat on opposite side



⇐ Reinstall both of the A-pillar gap covers <arrow> into the A-pillar and then stretch the door seal lip over them

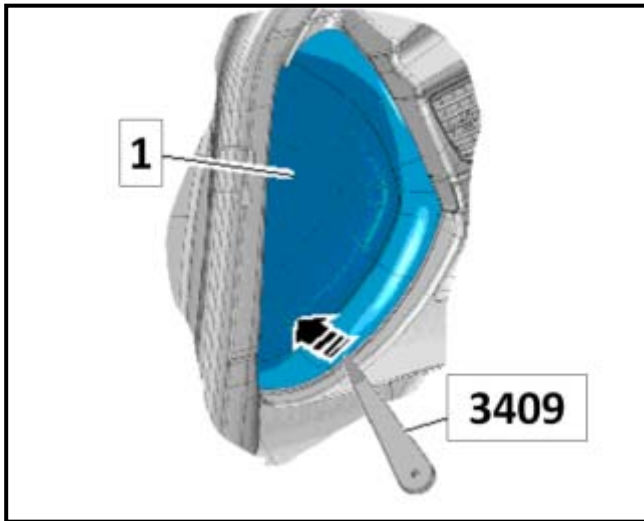

⇐ Reinstall both instrument panel side covers <1>

Section G – Reconnecting Battery



Caution: Accident risk.

Ensure no persons are in vehicle when reconnecting the battery. When working on pyrotechnic components (such as airbags and belt tensioners), the battery must be reconnected with the ignition switched ON

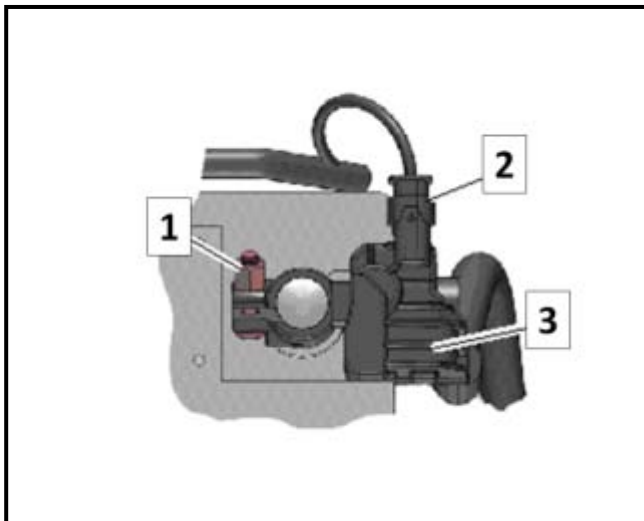

- Close all doors (windows other than sunroof should already be closed)
- Ensure that no one is inside of vehicle
- ⇐ Reconnect the ground terminal to the battery negative pole “-“ by hand and tighten the nut <1> to 5Nm
- Reinstall luggage compartment tool kit
- Reinstall spare wheel
- Close trunk
- Activate the one-touch up/one-touch down power window regulators
- Check all DTC memories and erase the “undervoltage” DTC if necessary using the Vehicle Diagnostic Tester



Tip: After connecting the power supply, the ABS warning lamp may only go out after the vehicle has been driven a few yards

WORK IS COMPLETE

Parts Return/Disposal

Properly destroy and dispose of removed parts in accordance with all state/local/provincial requirements, unless otherwise indicated and/or requested through SAGA