



6555 Katella Avenue • Cypress • California • 90630-5101 • (714) 761-7300 • Fax (714) 229-7944

December 06, 2011

Via Federal Express and E-mail (electronic and US mail)
Chief Administrator
National Highway Traffic Safety Administration
Associate Administrator for Safety Assurance (NVS-215)
1200 New Jersey Avenue SE, W46-421
Washington, DC 20590

Regarding: 11V-533

Dear Sir/Madam:

First, we thank the Agency for their review and approval of our proposed owner's notification. Enclosed please find hard copies of the Technical Bulletin issued to our dealers as well as the approved owner's letter. All Yamaha motorcycle and scooter dealers will receive a copy of this Technical Bulletin. To facilitate repairs, dealer's invoiced affected products under this recall receive an additional bulletin with a print-out of the affected VIN's for the units they have received. The mailing of both the dealer bulletin and owner's notification letter was completed approximately 11/24/11, so your assumption is correct as to the timing of our quarterly reports.

The determination date for this campaign was October 21, 2011. The starting production period for the affected vehicles (XVS95) was October, 2008, ending August, 2011 and (XVS1300) was August, 2006, ending March, 2007. As this campaign is international in scope we could only provide in our initial report an estimate of affected vehicles in the U.S. We are now obviously in a position to provide the accurate range. The Technical Bulletin provides the final VIN ranges by model with a total of 28,006 vehicles in the U.S. For TREAD purposes obviously it goes without saying similar campaigns are being conducted in other jurisdictions.

In the event I can provide further information or answer any questions, please do not hesitate to contact me. My direct telephone number is 714-761-7842. The fax number is 714-229-7944. My email is brad_franks@yamaha-motor.com.

Sincerely,

A handwritten signature in black ink, appearing to read "Brad Franklin", written over a horizontal line.

Brad Franklin
Manager, Government Relations

BRF/lf

cc: By Fed Ex and E-mail
Defects & Recall Information Analysis Division
Mrs. Kelly Schuler (via email)
Mr. Robert Young (via email)

Technical BULLETIN

©2011 YAMAHA MOTOR CORPORATION, U.S.A.

SAFETY RECALL

This modification has top priority. This bulletin must be performed immediately to ensure customer safety.

NOTE: Bulletins that announce a recall will have an "R" at the end of the bulletin number.

2009~2012 XVS95/CT and 2007 XVS13/CT MODELS FACTORY MODIFICATION CAMPAIGN – Fuel Hose Leakage

i

INTRODUCTION

Yamaha Motor Corporation, U.S.A. has decided that a defect which relates to motor vehicle safety exists in all 2009~2011 and certain 2012 XVS95 ("V Star 950") and XVS95CT ("V Star 950 Tourer") model motorcycles as well as all 2007 XVS13 ("V Star 1300") and XVS13CT ("V Star 1300 Tourer") model motorcycles. In affected units, there may not be a proper seal between the fuel pipes for the fuel injectors and the fuel hose that connects them due to an improperly molded fuel hose. Over time, pressurized fuel can begin leaking at the hose connection points, which could result in a fire hazard.

To correct this problem, Yamaha is initiating a Factory Modification Campaign. Affected units must have installed both a new fuel hose made with different material to improve hose rigidity and sealing performance during usage and new fuel pipes designed for improved sealing performance.

Yamaha is notifying all registered owners of affected motorcycles by mail. A copy of this letter is included in this bulletin. The customer should take the letter along with the affected motorcycle to an authorized Yamaha dealer for the modification.

A computer report listing all affected motorcycles invoiced to your dealership is included with this bulletin. Use the list to help ensure all motorcycles are modified. All sold motorcycles that have been registered with Yamaha will show the customer's name and address. Your dealership must notify the owner of any affected motorcycle that was actually sold but is listed as "unsold" in the report.

You must modify all affected motorcycles in your inventory as well as all customer-owned motorcycles brought to you for this service. Any affected motorcycle that you purchase from Yamaha in the future may also require modification. If you purchase a motorcycle from another dealer or Yamaha, check to see if the procedures in this bulletin have already been performed before you sell the motorcycle.

Motorcycles that are affected should not be operated until they are modified. It is a violation of Yamaha policy for your dealership to deliver any affected motorcycles to customers until the procedures in this bulletin are performed.

When the modification on each motorcycle is performed, follow the Warranty Information section of this bulletin to receive reimbursement. Be sure to use the Factory Modification Campaign procedures in Chapter 7 of the **Warranty and Y.E.S. Handbook** (LIT-11760-00-08).

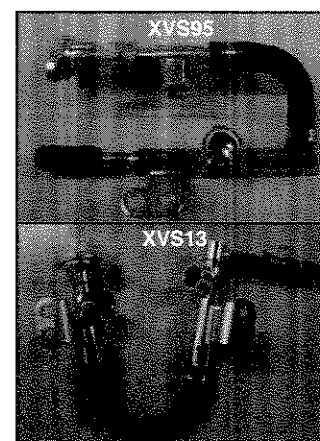



DEALER ACTION SUMMARY

Unsold

Units: Install the appropriate new fuel pipe and gasket kits on all affected units during setup before adding fuel to the fuel tank. On 2012 model XVS95 units, check for a white paint mark on the right side of the seat bracket bolt head (remove seat to check) before beginning the modification procedure; this mark indicates that the modification has already been performed (see Identification Procedure for more information).

Sold

Units: Install the appropriate new fuel pipe and gasket kits on all affected units whether or not there is leaking fuel. Check first to be sure the modification has not already been performed (see the Identification Procedure section in this bulletin).

Parts: Yes, order the appropriate new fuel pipe and gasket kits for each affected unit.

Warranty: Factory Modification Campaign. See the Warranty Information section of this bulletin. This modification applies to all affected units regardless of ownership or warranty status.

Notify

Customers: Yes. You must immediately contact any customer whose motorcycle shows as unregistered on the enclosed report. Yamaha has sent letters to customers whose motorcycles were registered with state departments of motor vehicles as of 10/31/11, as well as any motorcycles registered for warranty after 10/31/11 up to and including 11/20/11.



AFFECTED RANGE

All 2009~2011 XVS95/CT

VN01E-0000018~0011965

VN01Y-0000033~0001255

2012 XVS95/CT

VN01E 0011966~0014220

VN01Y-0001256~0001486

All 2007 XVS13/CT

VP24E-0000025~0005584

VP24Y-0000009~0000963

VP25E-0000007~0005467

VP25Y-0000007~0000671



SERVICE PROCEDURES

XVS95/CT Service Procedure

IMPORTANT: On 2012 model XVS95 units, check for a white paint mark on the right side of the seat bracket bolt head (remove seat to check) before beginning the modification procedure; this mark indicates that the modification has already been performed (see Identification Procedure for more information).

Refer to the Service Manual (LIT-11616-22-60) for specific procedures. Perform this modification with the motorcycle on a stand and front wheel straight and secured.

⚠ WARNING

- Cover fuel hose connections with a cloth when disconnecting them. Residual pressure in the fuel lines could cause fuel to spurt out when removing the hose.
- Although the fuel has been removed from the fuel tank, be careful when removing the fuel hose, since there may be fuel remaining in it.
- Gasoline is flammable. Use a rag to absorb any fuel that leaks from the fuel pump or fuel tank during and after removal. Properly dispose of any fuel-soaked rag.
- Perform this procedure away from any sparks, flames, or other sources of ignition.

1. Remove the rider seat.
2. Disconnect the negative (-) battery terminal.
3. Remove the side cover (cylinder head) [1].
4. If the unit has been operated or had fuel added, drain the fuel from the fuel tank through the filler neck using a suitable pump.

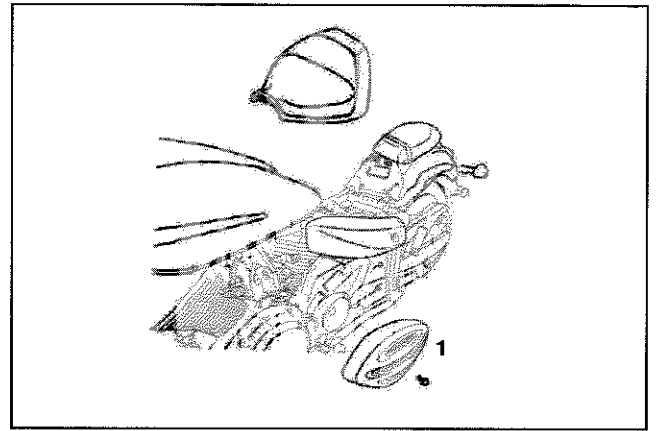

5. Remove the two fuel tank bracket bolts [2].
6. Disconnect:
 - Meter coupler 1 [3]
 - Meter coupler 2 [4]
 - Fuel pump coupler (black) [5]
 - Fuel return hose [7]

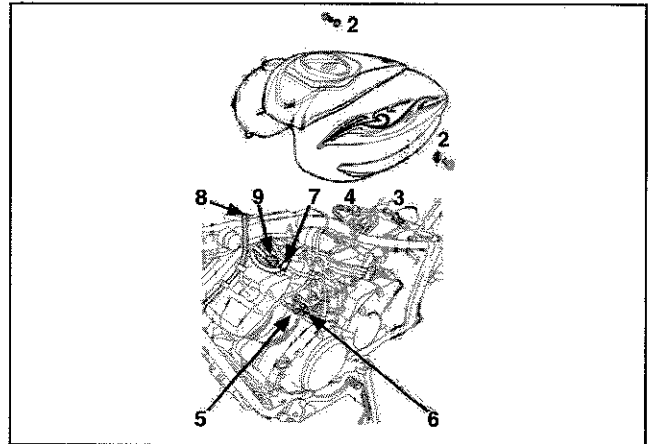

7. Disconnect the drain hose [8] from the top of the rollover valve on the left front frame downtube [A].

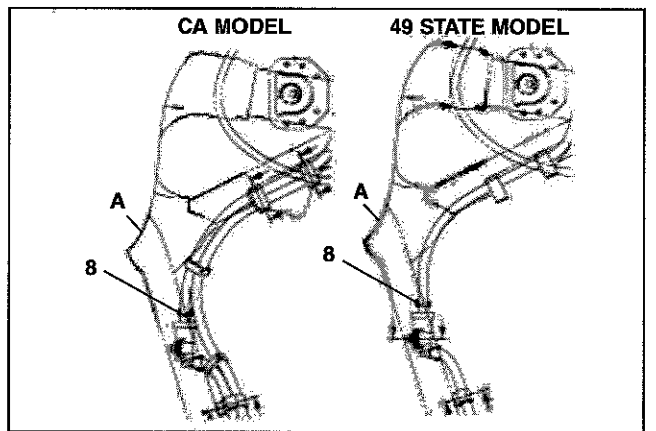

8. Disconnect the fuel hose [9] connection at the fuel rail (see illustration above).

TIP:

- Before removing the hose, place a few rags in the area under where it will be removed.
- Remove the fuel hose and connectors manually without using any tools.
- To remove the hose [9] from the fuel rail, slide the fuel hose connector cover [10] on the end of the hose in the direction of the arrow shown, press the two buttons [11] on the sides of the connector, and then disconnect the fuel hose.

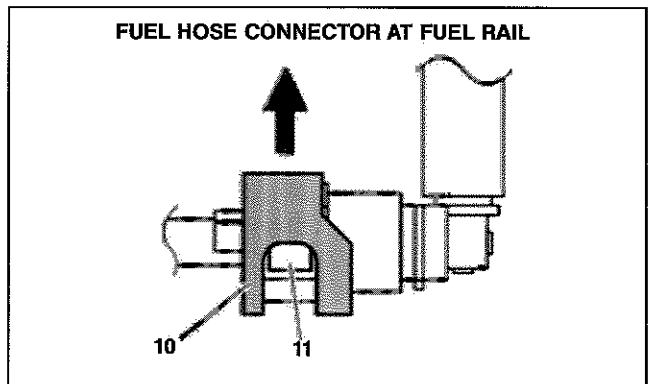

9. Remove the fuel tank assembly.

NOTICE:

Take care handling the fuel tank as the fuel pump is on the bottom.

Replacing the Pipe Inlet Assembly

IMPORTANT:

If you are unfamiliar with this model's wire, cable, and hose routing, it is highly recommended that you take photos of the routing of all harnesses, cables, and hoses before disconnecting or removing them.

10. Remove the injector lead wire couplers [12].

11. Remove the fuel pipe retainer bolts [13].

TIP:

You will not be reusing the bolts; new ones are provided in the kit. Discard these now.

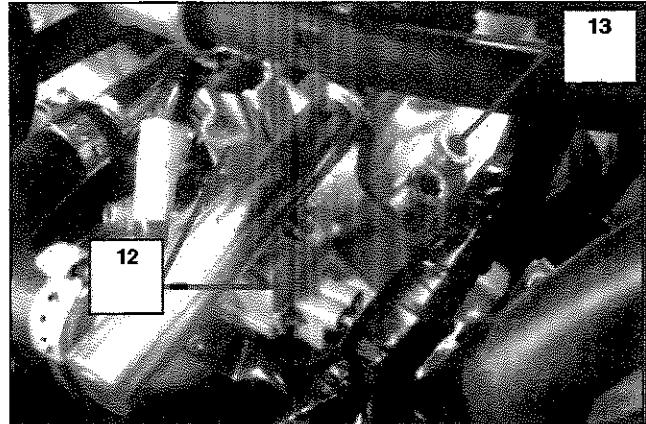

12. Remove the following:

- Pipe inlet assembly [14] from the unit
- Injectors [15] from the pipe assembly

TIP:

You will not be reusing the injector O-ring and gaskets [16]; new ones are provided in the kit. Discard these now.

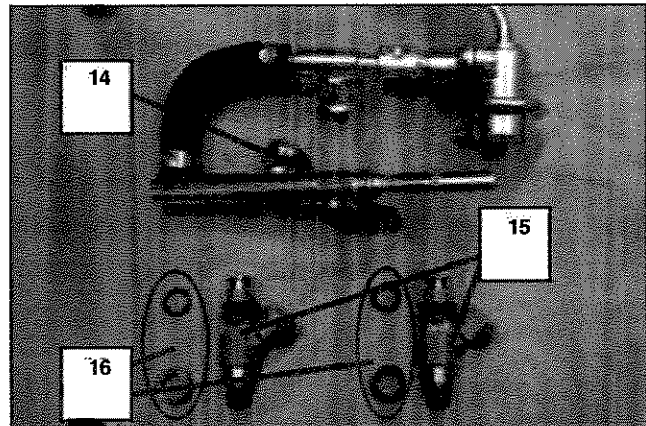

13. Remove the pressure regulator [17]. You will be reusing the pressure regulator bolts, so remove any thread locking compound found on the threads.

TIP:

You will not be reusing the pressure regulator O-ring [18]; a new one is provided in the kit. Discard it now.

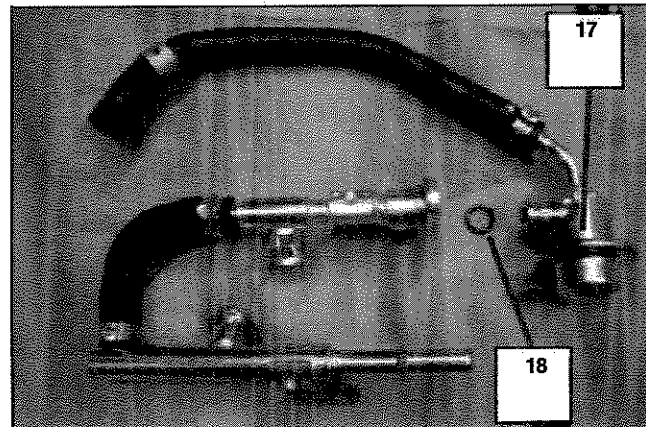

14. Replace the pipe inlet assembly [Kit Ref. 1].
15. Apply Loctite® 242™ to the threads of the original pressure regulator bolts.
16. Assemble the pressure regulator using the O-ring supplied in the kit [Kit Ref. 3].
17. Assemble the injectors using the O-rings supplied in the kit [Kit Ref. 2] and the manifold gaskets from Gasket Kit 2.
18. Apply Loctite® 242™ to the treads of the NEW bolts supplied in the kit [Kit Ref. 4].
19. Assemble the pipe inlet assembly to the intake manifold and tighten bolts [12] to specification.
Fuel pipe bolts: 10 Nm (1 m•kg, 7.2 ft•lb)
20. Install the injector lead wire couplers [13].

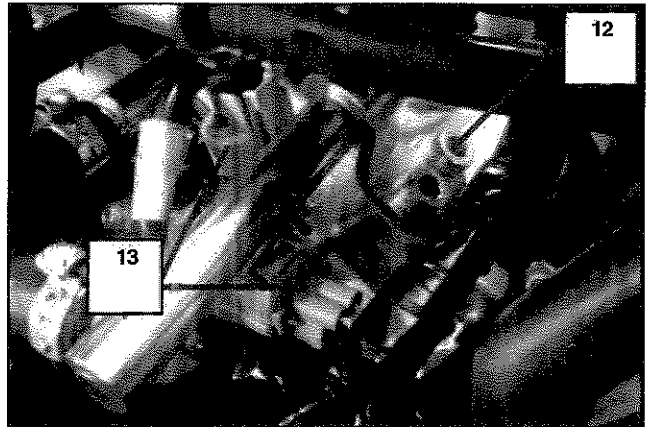
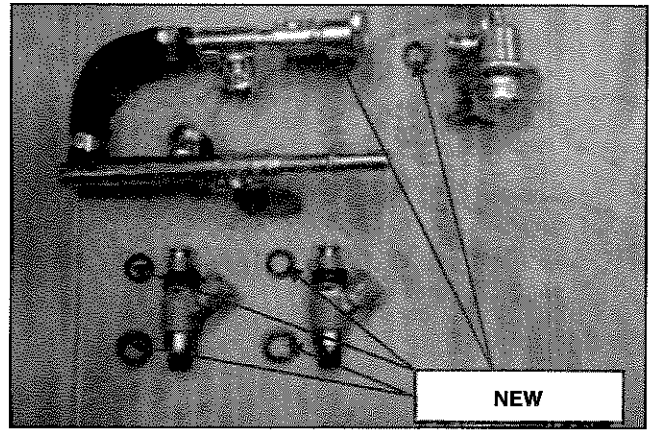

Installing the Fuel Tank

21. Position the tank on the motorcycle and install the fuel hose [9] to the fuel pump until a distinct “click” is heard. Slide the fuel hose connector cover [16] on the end of the hose in the direction of the arrow shown.

NOTICE:

When installing the fuel hose, make sure that it is securely connected, and that the fuel hose connector cover on the fuel hose is in the correct position, otherwise the fuel hose will not be properly installed.

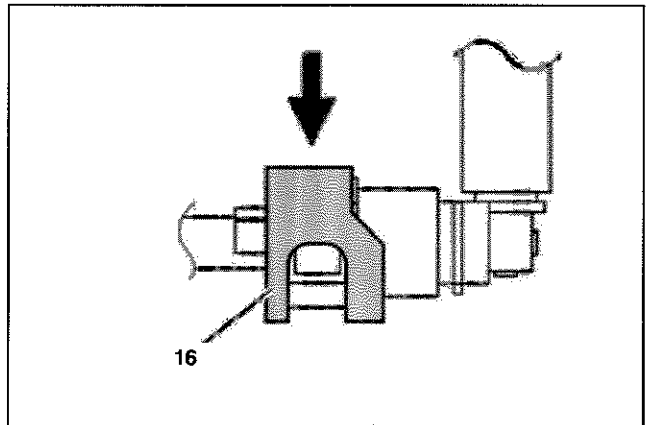

22. Reconnect:
 - Fuel tank drain hose [8] to rollover valve

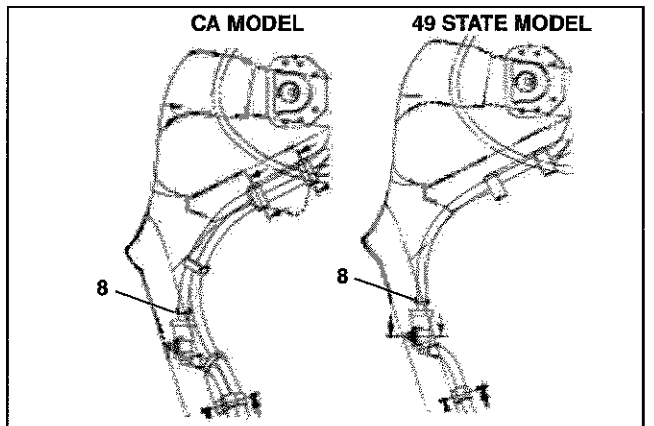

- Fuel return hose [7]
- Fuel sender coupler [6]
- Fuel pump coupler [5]
- Meter coupler 2 [4]
- Meter coupler 1 [3]

23. Install the two fuel tank bracket bolts [2] and tighten to specification.
Fuel tank bracket bolts: 23 Nm (2.3 m•kg, 17 ft•lb)
24. Return all fuel previously removed from the fuel tank.
25. Reconnect the negative (–) battery terminal.
26. Install the rider seat.
27. Install the side cover (cylinder head) and tighten the bolt to specification.
Side cover bolt: 7 Nm (0.7 m•kg, 5.1 ft•lb)
28. Return any clean fuel previously drained to the fuel tank.
29. Start the engine and check to be sure there are no fuel leaks.
30. After the modification is complete, put a punch mark next to the VIN as described in *Identification Information* below.

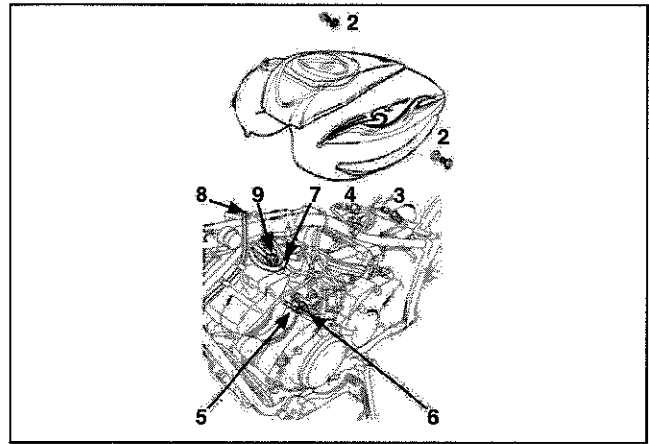

XVS13/CT Service Procedure

Refer to the Service Manual (LIT-11616-20-42) for specific procedures. Perform this modification with the motorcycle on a stand and front wheel straight and secured.

⚠ WARNING

- **Cover fuel hose connections with a cloth when disconnecting them. Residual pressure in the fuel lines could cause fuel to spurt out when removing the hose.**
- **Although the fuel has been removed from the fuel tank, be careful when removing the fuel hose, since there may be fuel remaining in it.**
- **Gasoline is flammable. Use a rag to absorb any fuel that leaks from the fuel pump or fuel tank during and after removal. Properly dispose of any fuel-soaked rag.**
- **Perform this procedure away from any sparks, flames, or other sources of ignition.**

1. Remove the rider seat.
2. Remove the lock bracket bolts [3].
3. Remove/disconnect the following:
 - Battery cover band,
 - Battery cover,
 - Tool kit,
 - Tool kit tray,
 - Negative (-) battery terminal [4].
4. If the unit has been operated or had fuel added, drain the fuel from the fuel tank through the filler neck using a suitable pump.
5. Remove/disconnect the following:

IMPORTANT:

If you are unfamiliar with this model's wire, cable, and hose routing, it is highly recommended that you take photos of the routing of all harnesses, cables, and hoses before disconnecting or removing them.

- Fuel tank bolts [5]
- Fuel sender coupler [6]
- Fuel cock hose [7]

TIP:

Before removing the hose, turn fuel petcock to the OFF position and place a few rags in the area under where it will be removed.

- Air vent hose [8]
- Fuel tank
- Left side panel [11]

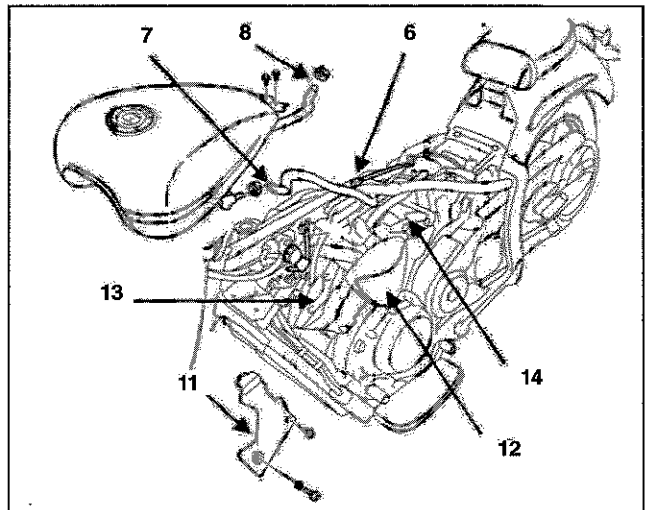
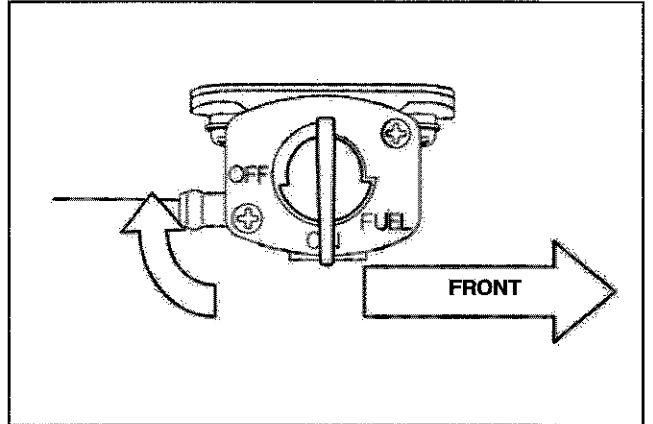
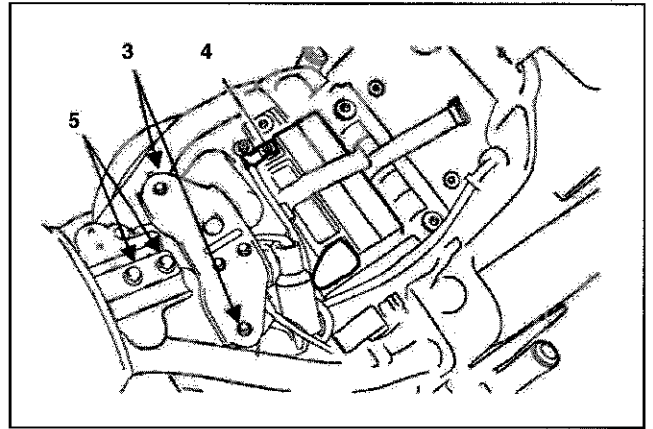

6. Remove/disconnect the following from the chassis:

- Fuel tank overflow hose [9]
- Fuel tank breather hose [10]

7. Remove/disconnect the following (refer to illustration on previous page):

- Left side cover [12]
- Front cylinder left cover [13]
- Rear cylinder right cover [14]

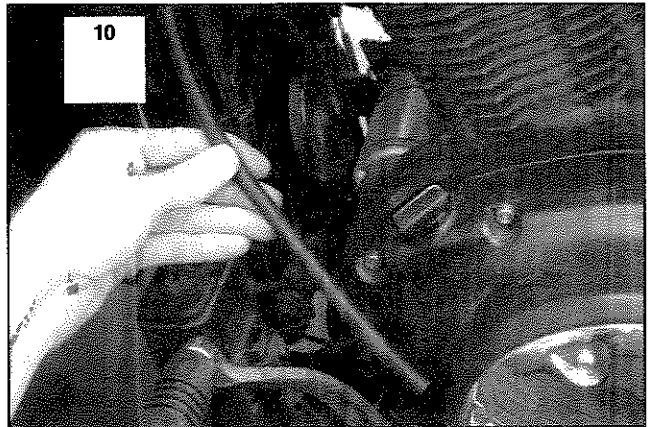

8. Remove the left side cover bracket [15].



9. Remove/disconnect the following:

- Air filter cover [16]
- Air filter element
- Crankcase breather hose [17]
- Air filter case [18]

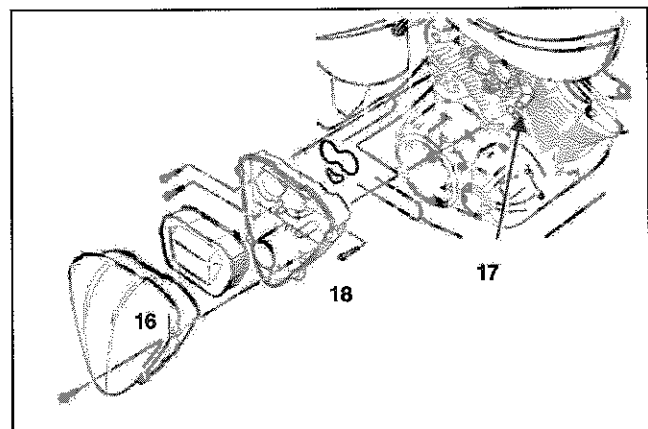

- TPS coupler [19]
- Intake air pressure sensor hoses [20]
- California models only: Remove the emission canister hose from between the two intake air pressure hoses on the throttle body.
- Throttle body [22]

TIP:

Do not remove the throttle cables from the throttle body pulley; just move the throttle body aside and out of the way.

- ISC coupler [21]

TIP:

You will not be reusing the throttle body gasket [23]; a new one is provided in the kit. Discard the original throttle body gasket now.

NOTICE:

Do not allow anything to enter the intake ports.

10. Remove rear cylinder right cover [24] and unplug the rear cylinder spark plug cap.

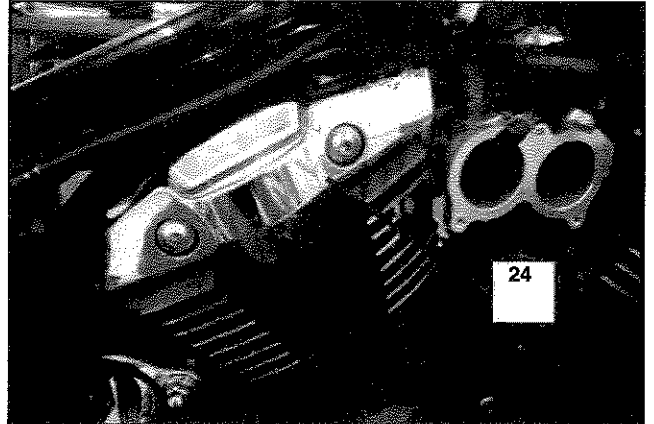
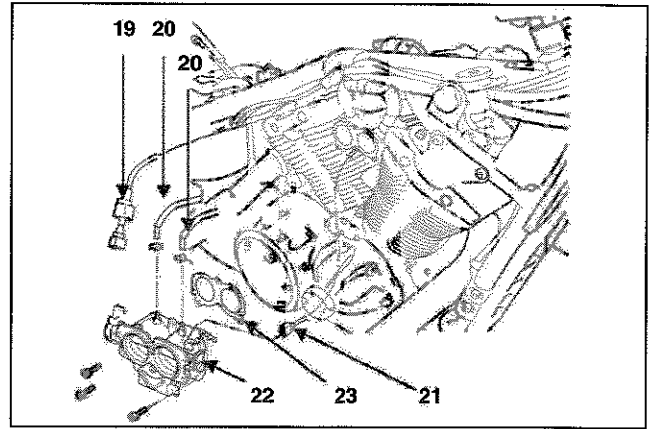

11. Remove the re-useable tie wrap [25]. Keep this tie wrap as it will be re-used.
12. Remove the resonator hose [26] from the intake manifold.
13. Disconnect the ISC/injector couplers [27].
14. Cut the black tie wraps [28], [29].

TIP:

Wraps shown in white here for clarity. New ones are provided in the kit. Discard them now.

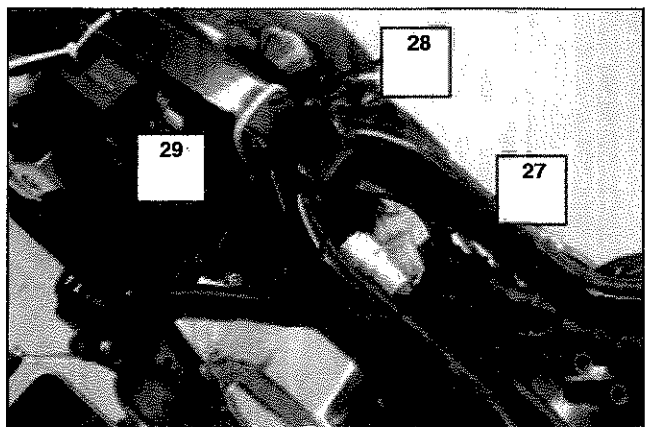
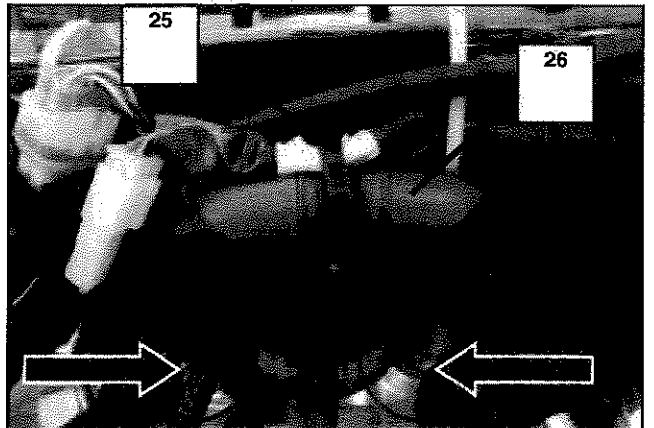

15. Pull couplers out the left side of frame.



16. Disconnect the fuel hose coupler [30].

TIP:

- Before removing the hose, place a few rags in the area under where it will be removed.
- Remove the fuel hose and connectors manually without using any tools.
- To remove the fuel hose [30] from the fuel rail, slide the fuel hose connector cover [31] on the end of the hose in the direction of the arrow shown, press the two buttons [32] on the sides of the connector, and then disconnect the fuel hose.

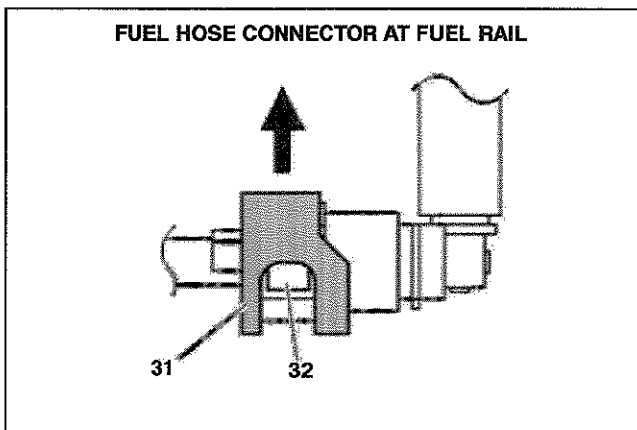

17. Disconnect and remove the crankcase breather hose [17] out to the left.



18. Disconnect the following:

- Ignition coil lead couplers [33]

TIP:

Pay attention to the relative placement of these four couplers (take photo if possible).

- Main switch lead couplers (blue and white) [34]
- Intake air pressure sensor couplers [35]
- Oil level sensor coupler [36]
- Radiator fan motor coupler [37]
- Sidestand switch coupler [38]
- Tie wrap [51]. A new one is provided in the kit. Discard now.
- Coolant temperature sensor

19. Pull the wire harness out towards the rear.

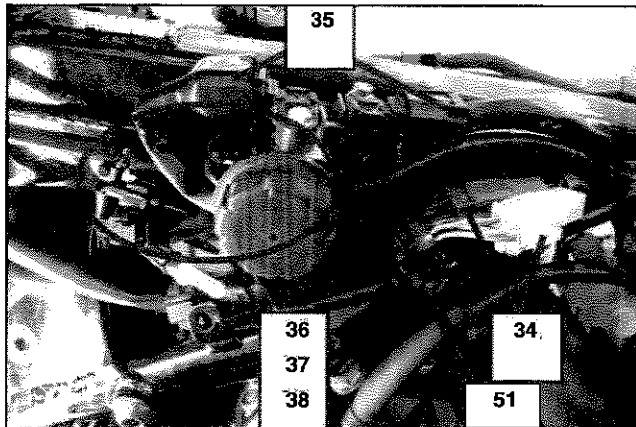
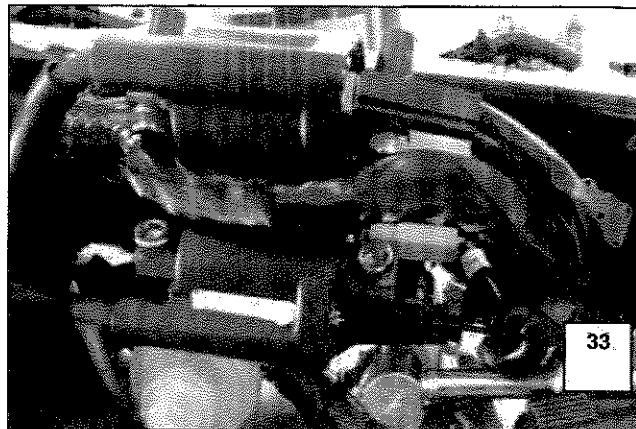

20. Remove the ignition coil bracket [39]. Leave the coils on the bracket.

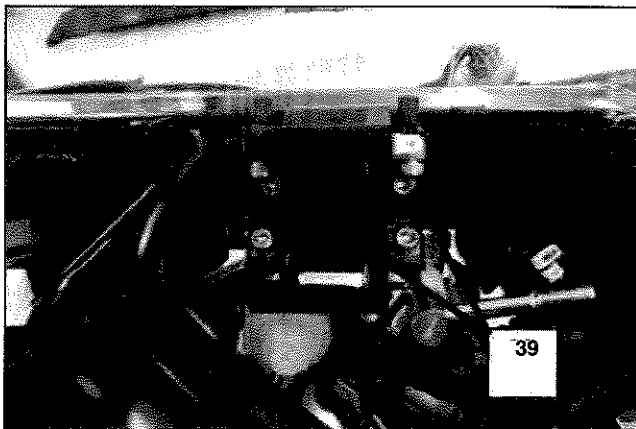

21. Loosen only the front intake manifold retainer clamp [40].

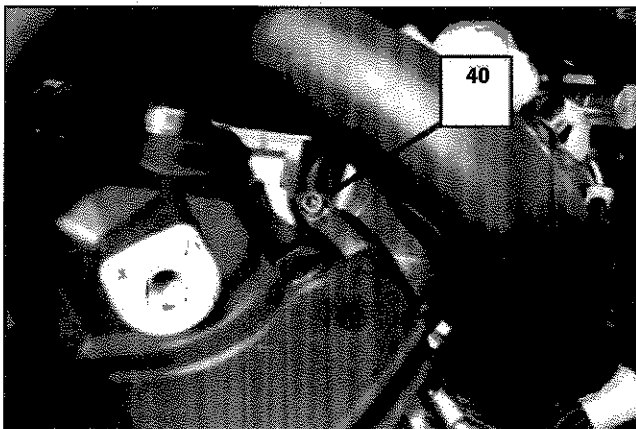

22. Remove only the rear intake manifold retainer bolts [41].
23. Pull the intake manifold [42] up and to the rear away from the front cylinder intake manifold clamp [40].
24. Remove intake manifold assembly [42].

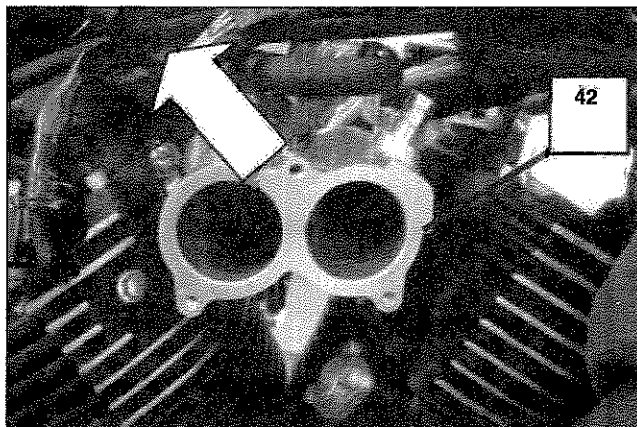
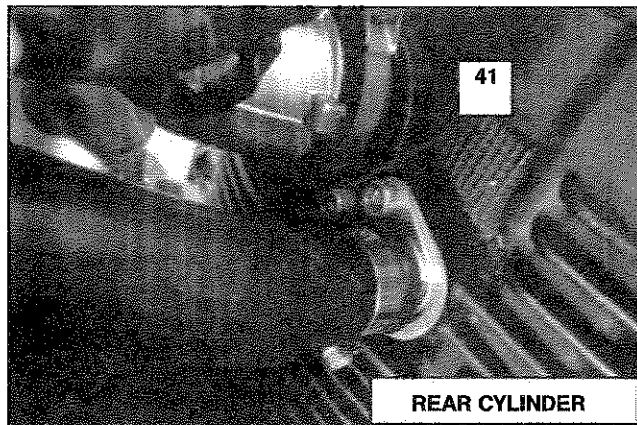

Replacing the Pipe Inlet Assembly

25. Remove the fuel pipe retainer bolts [43].

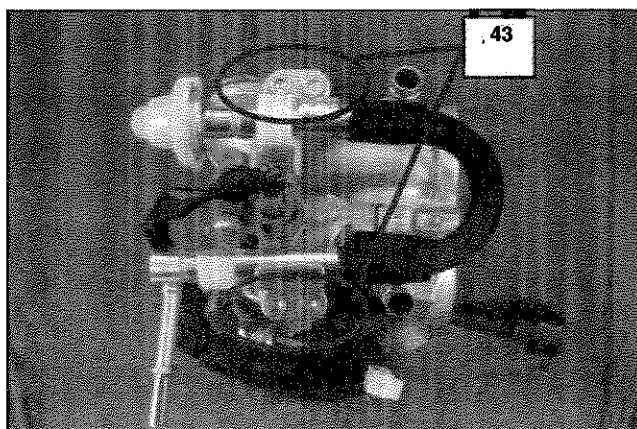

26. Cut the short black tie wrap [44] and discard. A new one is provided in the kit.
27. Disconnect the pipe inlet assembly [45].
28. Remove the injector seals [46] and discard. New ones are provided in the kit.
29. Remove the injectors [47] from the pipe inlet assembly.
30. Remove the O-ring [48] from each injector and discard. New ones are provided in the kit.

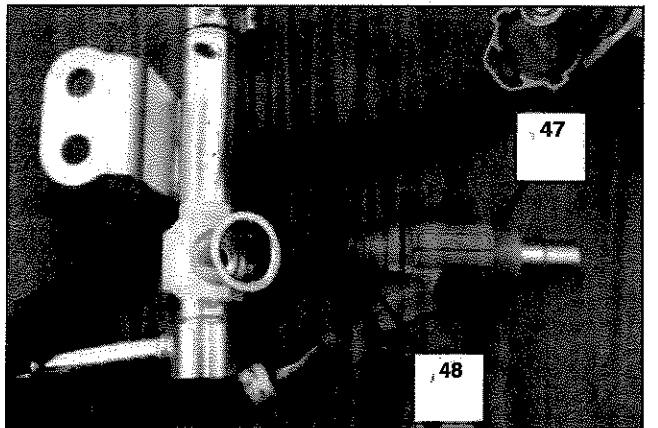
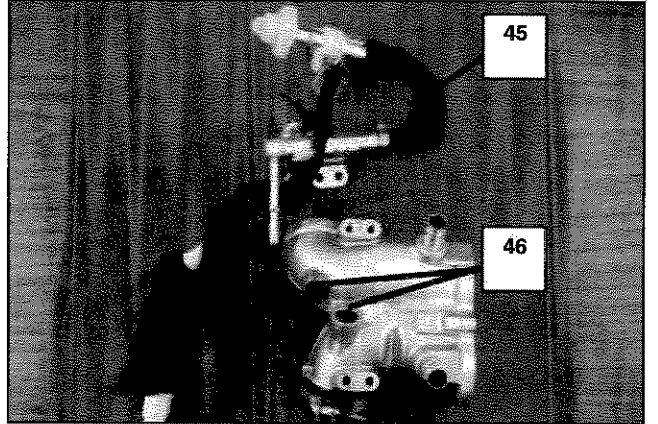
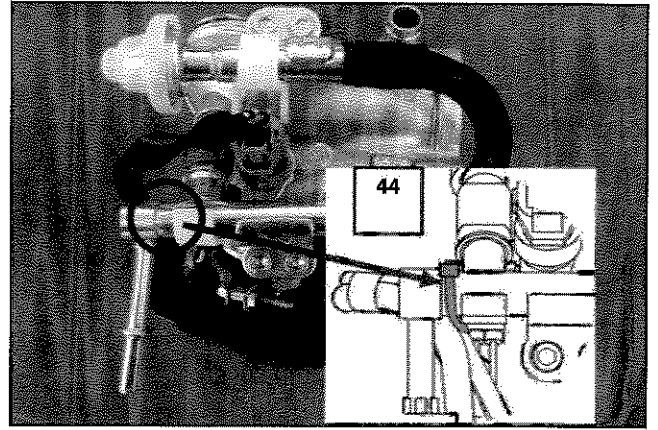

31. Remove the holders [49] from the old pipe inlet assembly and install these to the NEW pipe inlet assembly [Kit Ref. 1].

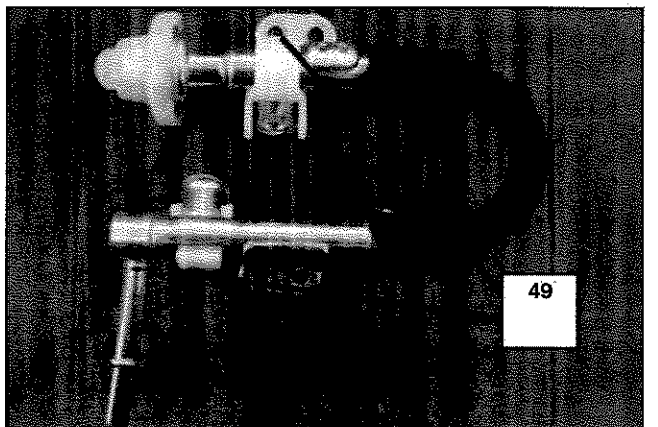

32. Install the NEW O-ring [48] onto the injectors [Kit Ref. 2].
33. Install the injectors [47] onto the pipe inlet assembly.
34. Install the injector seals [46] from Gasket Kit 2.
35. Install the pipe inlet assembly [45] onto the manifold and tighten the fuel pipe retainer bolts [43]. Fuel pipe bolts (4): 10 Nm (1 m•kg, 7.2 ft•lb)

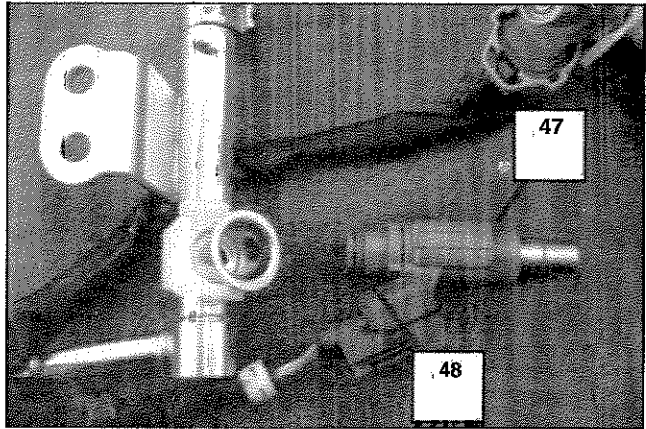

36. Apply a small amount of Yamalube motor oil to the manifold assembly mating surfaces [50] to aid installation.

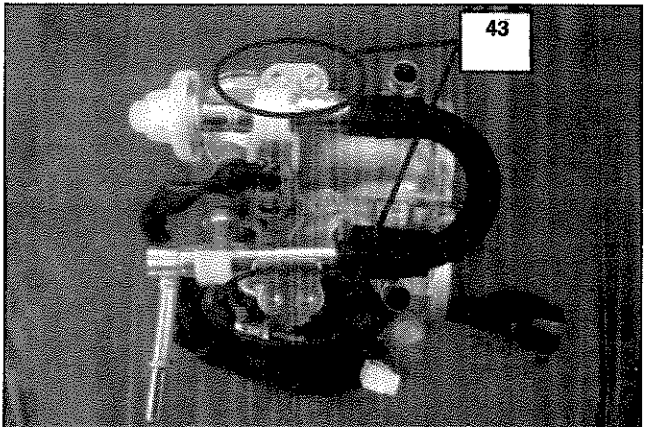
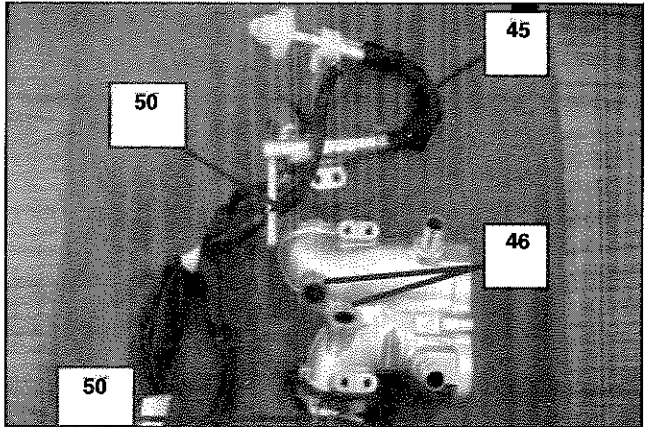

37. Install the short black tie wrap [Kit Ref. 4].

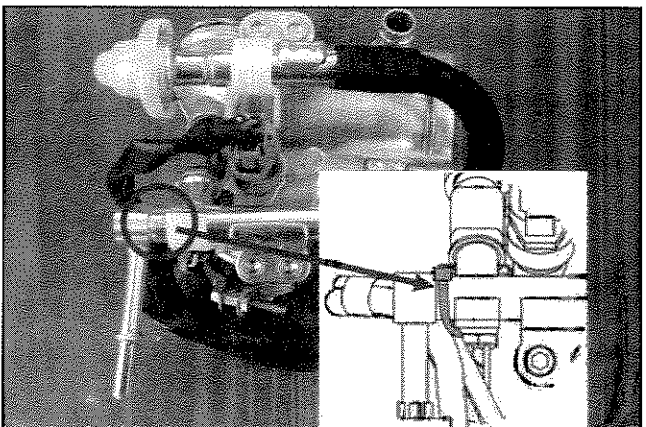

38. Install the intake manifold assembly [42].



39. Install the rear intake manifold retainer bolts [41] and tighten to specification.
Intake manifold retainer bolts (2): 10 Nm (1 m•kg, 7.2 ft•lb)

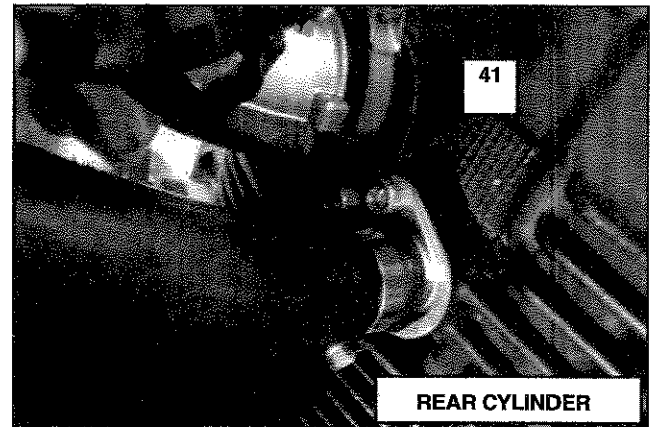

40. Tighten to specification the front intake manifold retainer clamp [40].
Intake manifold clamp screw (1): 4 Nm (0.4 m•kg, 2.9 ft•lb)

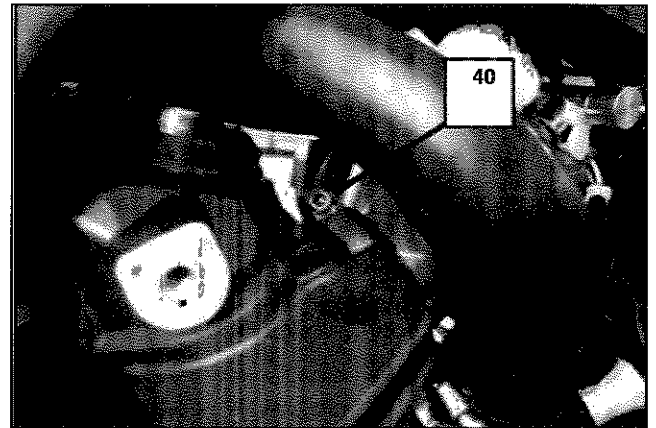

41. Route the spark plug leads. Install the ignition coil bracket [39] and tighten to specification.
Ignition coil bracket bolts (2): 10 Nm (1 m•kg, 7.2 ft•lb)

42. Pull the wire harness back towards the front.

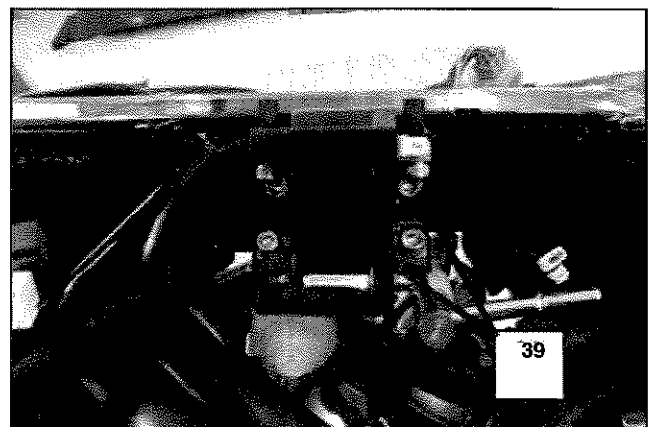

43. Reconnect the following:

- Ignition coil lead couplers [33]

TIP:

Pay attention to the relative placement of these four couplers (see step 18).

- Main switch lead couplers (blue and white) [34]
- Intake air pressure sensor couplers [35]
- Oil level sensor coupler [36]
- Radiator fan motor coupler [37]
- Sidestand switch coupler [38]
- Coolant temperature sensor

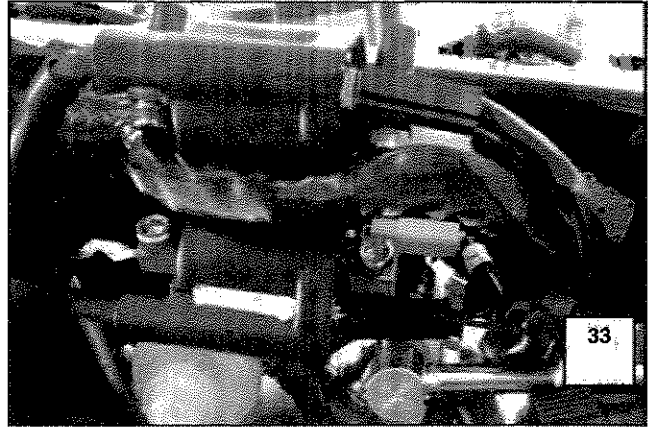

NOTICE: Ensure the fuel tank overflow hose [9] (not shown) and the fuel tank breather hose [10] (not shown) are routed in front of the forward fuel tank mount. See blue arrow.

44. Install the tie wrap [51] [Kit Ref. 5].

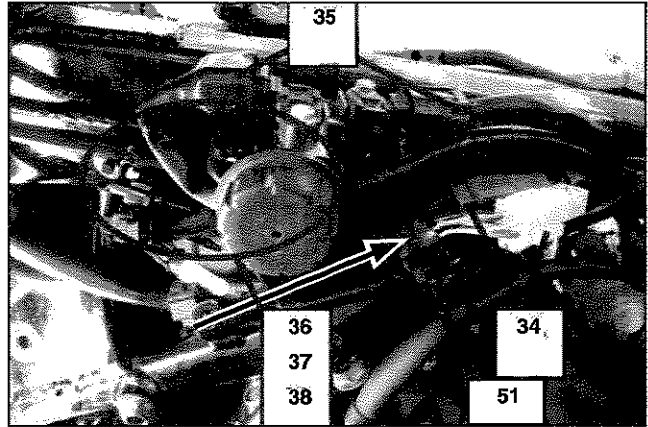

45. Install the tie wrap [29] [Kit Ref. 6]. **NOTICE: Do not clamp the coolant overflow hose.**

46. Re-route crankcase breather hose [17] under and to the front of the intake manifold.

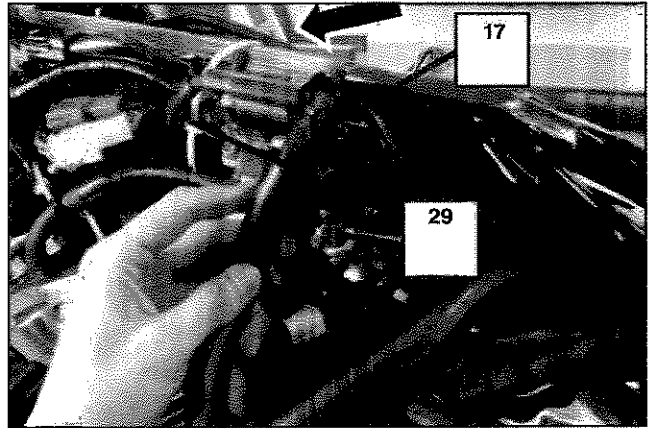

47. Connect the fuel hose coupler [30]. Install the fuel hose securely onto the fuel rail until a distinct “click” is heard. To install the fuel hose onto the fuel rail, slide the fuel hose connector cover [31] on the end of the hose in the direction of the arrow shown.

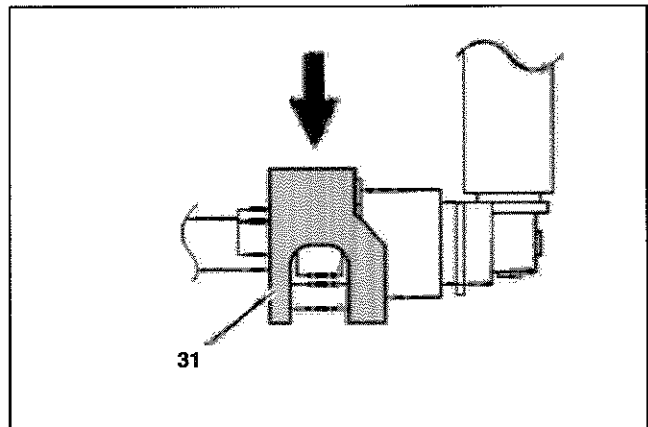

48. Route the ISC/injector couplers under and through the frame cradle.



49. Reconnect the ISC/injector couplers [27].

50. Install the tie wrap [28] [Kit Ref. 6].

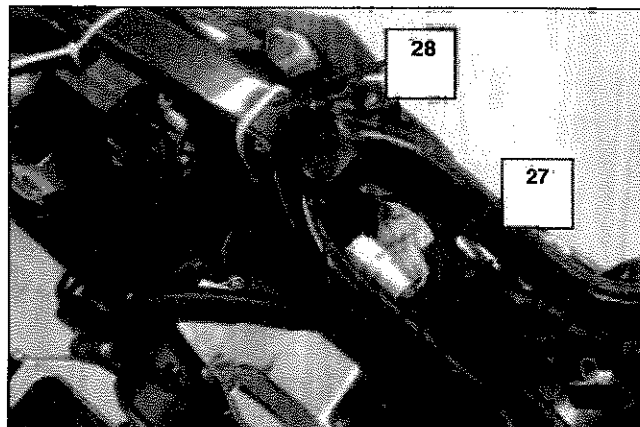

51. Install resonator hose [26] and re-useable tie wrap [25] (removed in step 11).

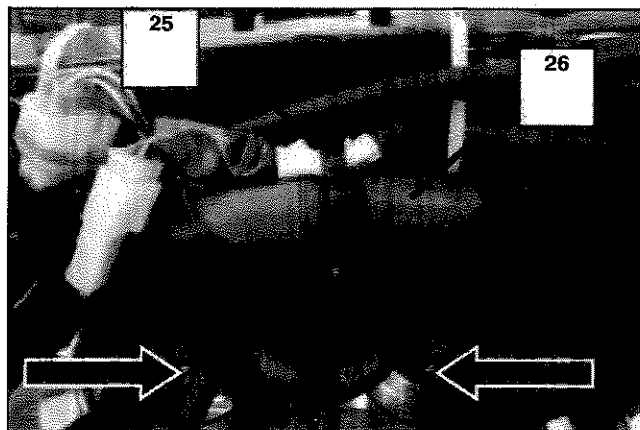

52. Install rear cylinder spark plug cap and rear cylinder right cover [24]. Tighten bolts to specification.
Cylinder cover bolts (2): 8 Nm (0.8 m•kg, 5.8 ft•lb)

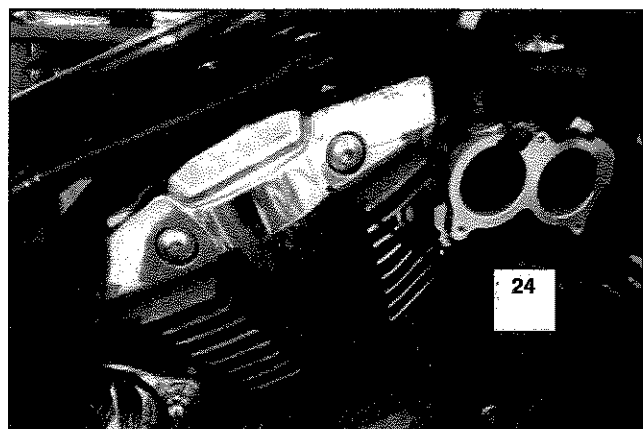

53. Install/reconnect the following:

- ISC coupler [21]
- Emission canister hose (California models)
- NEW throttle body gasket [23] [Kit Ref. 3]
- Throttle body [22]
- Throttle body bolts (3): 10 Nm (1 m•kg, 7.2 ft•lb)
- Intake air pressure sensor hoses [20]
- TPS coupler [19]
- Crankcase breather hose [17]
- Air filter case [18]
- Air filter case bolts (3): 4 Nm (0.4 m•kg, 2.9 ft•lb)
- Air filter element
- Air filter cover [16]

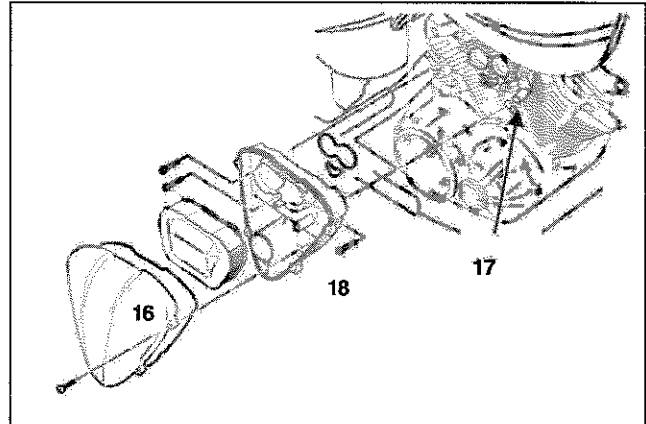
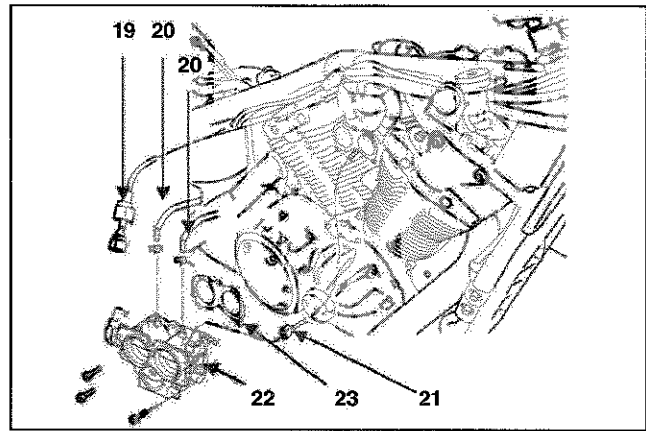

54. Install/reconnect the following:

- Left side cover bracket [15]
- Left side cover bracket bolts (2): 10 Nm (1 m•kg, 7.2 ft•lb)
- Rear cylinder left cover [14]
- Front cylinder left cover [13]
- Rear/front cylinder cover bolts (4): 8 Nm (0.8m•kg, 5.8 ft•lb)
- Left side cover [12]
- Side cover bolt: 4 Nm (0.4 m•kg, 2.9 ft•lb)
- Left side panel [11]
- Fuel tank overflow hose (see step 6)
- Fuel tank breather hose (see step 6)

NOTICE: Do not pinch the fuel tank breather hose.

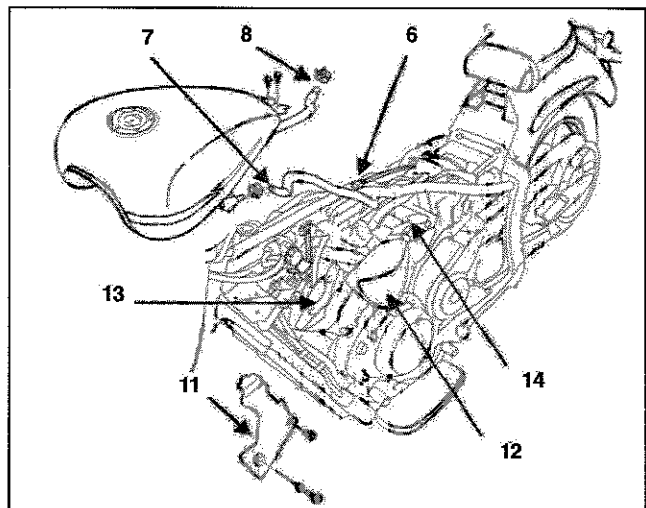

- Fuel cock hose [7]
TIP: Before installing the fuel tank, turn the fuel petcock to the ON position.
- Fuel tank
- Air vent hose [8]
- Fuel sender coupler [6]
- Fuel tank bolts [5]
Fuel tank bolts (2): 23 Nm (2.3 m•kg, 17 ft•lb)

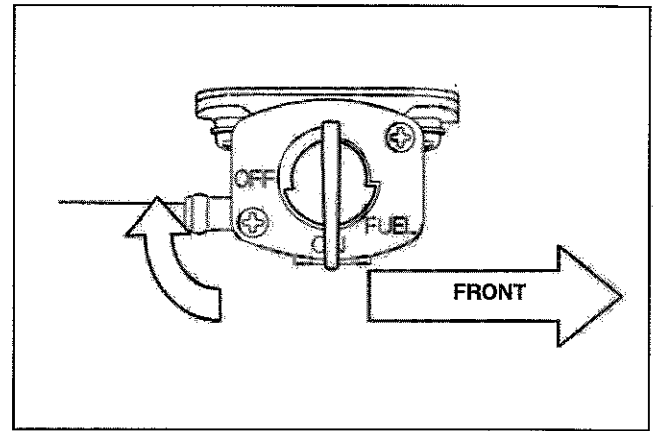

55. Return all fuel previously removed from the fuel tank.

56. Install/Reconnect the following:
- Negative (-) battery terminal [4]
 - Tool kit tray
 - Tool kit
 - Battery cover
 - Battery cover band
 - Rider seat

57. Start the engine and check to be sure there are no fuel leaks.

58. After the modification is complete, put a punch mark next to the VIN as described in Identification Information below.

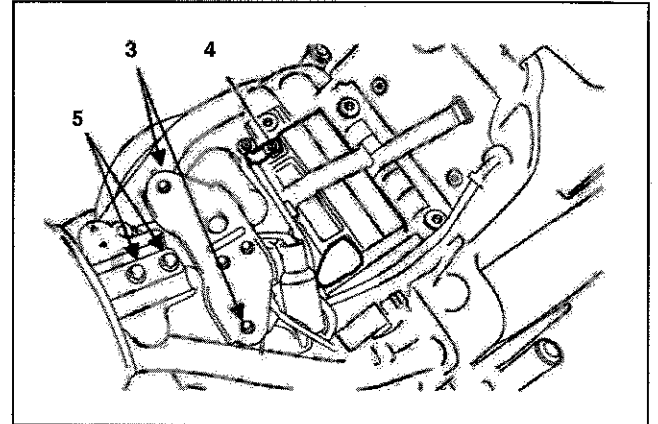



IDENTIFICATION PROCEDURE

After modifying a unit, make a punch mark next to the Vehicle Identification Number (VIN) as shown in the adjacent illustrations (1). Check for this punch mark if you encounter an unfamiliar unit. You can also check unit status on YDS or by contacting your Regional Technical Advisor.

IMPORTANT: On 2012 model XVS95 units, check for a white paint mark on the right side of the seat bracket bolt head (remove seat to check) before beginning the modification procedure; this mark indicates that the modification has already been performed.

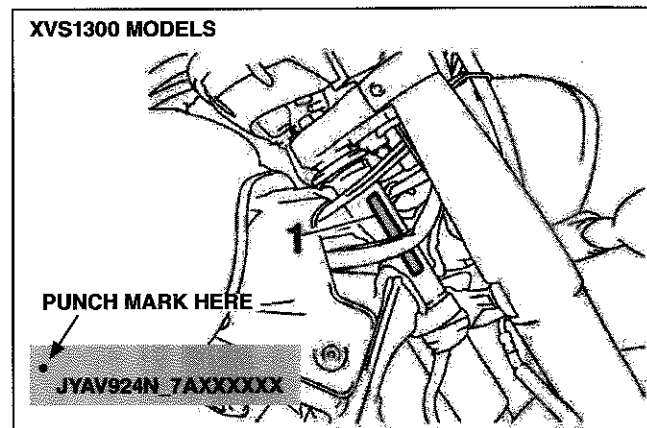
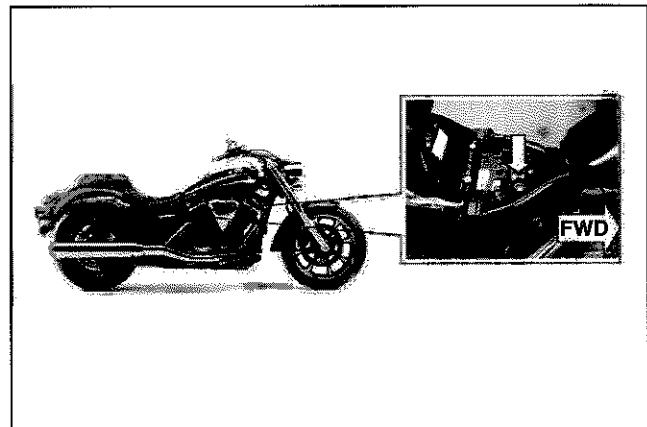
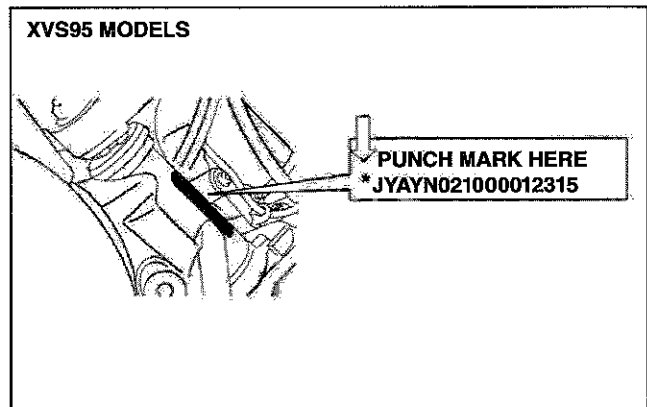

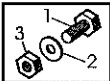

PARTS INFORMATION

For each affected unit, order a Fuel Pipe Kit and a Gasket Kit.

XVS95/CT

Part Number	Description	Qty.	Dealer Cost
90891-10215-00	XVS950 Fuel Pipe Kit	1	\$98.89
5S7-W0002-00-00	Gasket Kit 2	1	\$3.12

XVS950 Fuel Pipe Kit Contents

Reference	Description	Qty.
1	Pipe Inlet Assembly	1
2	O-Ring	2
3	O-Ring	1
4	Bolt	4

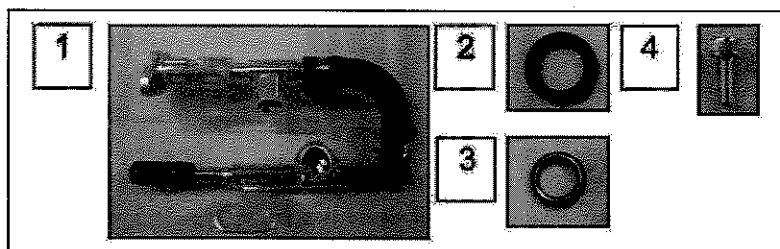

Gasket Kit 2 Contents

Description	Qty.
Gasket, Manifold (for Fuel Injectors)	2

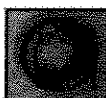

XVS13/CT

Part Number	Description	Qty.	Dealer Cost
90891-10216-00	XVS1300A/CT Fuel Pipe Kit	1	\$95.04
5S7-W0002-00-00	Gasket Kit 2	1	\$3.12

XVS1300A/CT Fuel Pipe Kit Contents

Reference	Description	Qty.
1	Pipe Inlet Assembly	1
2	O-Ring	2
3	Seal	1
4	Clip (Short Tie Wrap)	1
5	Band (Medium Tie Wrap)	1
6	Clamp (Long Tie Wrap)	2

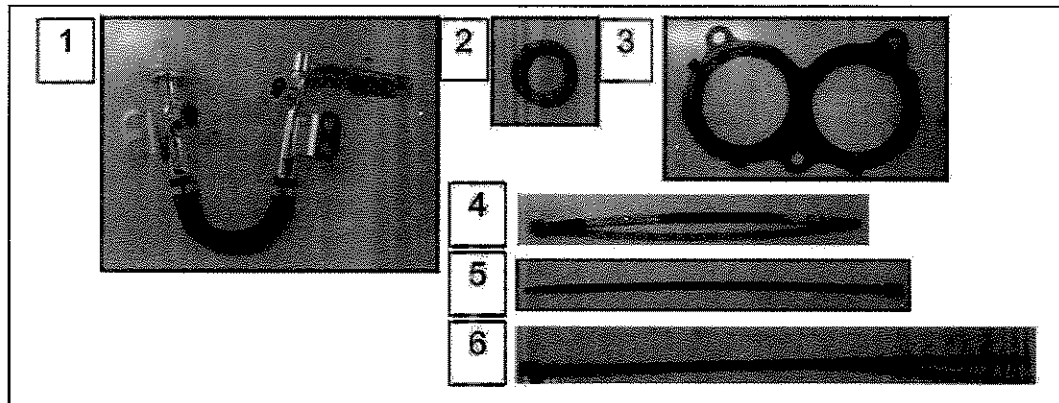

Gasket Kit 2 Contents

Description	Qty.
Gasket, Manifold (for Fuel Injectors)	2





YAMAHA MOTOR CORPORATION, U.S.A.

6555 KATELLA AVENUE, CYPRESS, CALIFORNIA 90630-5101 800-962-7926

IMPORTANT SAFETY RECALL NOTICE

November 21, 2011

Dear Yamaha Owner:

This notice is sent to you in accordance with the requirements of the National Traffic and Motor Vehicle Safety Act. Yamaha Motor Corporation, U.S.A. has decided that a defect which relates to motor vehicle safety exists in all 2009~2011 and certain 2012 XVS95 ("V Star 950") and XVS95CT ("V Star 950 Tourer") model motorcycles as well as all 2007 XVS13 ("V Star 1300") and XVS13CT ("V Star 1300 Tourer") model motorcycles. Our records show that you own the affected motorcycle shown above.

The reason for this recall:

In affected motorcycles, there may not be a proper seal between the fuel pipes for the fuel injectors and the fuel hose that connects them due to an improperly molded fuel hose. Over time, pressurized fuel can begin leaking at the hose connection points, which could result in a fire hazard.

What Yamaha and your dealer will do:

To correct this defect, your authorized Yamaha dealer will both a new fuel hose made with different material to improve hose rigidity and sealing performance during usage and new fuel pipes designed for improved sealing performance. **There will be no charge to you for this procedure.** Installing the new parts takes about 1 hour on V Star 950 models and about 1 hour and 40 minutes on V Star 1300 models, although your dealer may need to keep your motorcycle longer depending upon their schedule.

What you should do now:

Please call your Yamaha dealer to make a service appointment to have this procedure performed. At that same time, you can find out how long they expect to keep your motorcycle for this service. Remember to take this letter with you when you take in your motorcycle. **You should not ride your motorcycle until this modification is performed. Additionally, you should not park your motorcycle near sparks, open flames, or other sources of ignition until it is modified.**

If you are unable to return to the Yamaha dealer who sold you the motorcycle, this service will be performed by any authorized Yamaha Motorcycle dealer. For the name of a dealer near you, call 1-800-88-YAMAHA or visit the Yamaha web site at: www.yamaha-motor.com.

If you have had this repair performed before you received this letter, you may be entitled to receive reimbursement for the cost of obtaining a pre-notification remedy of the problem associated with this repair. For more information, contact Yamaha Customer Relations at 1-800-962-7926.

Federal regulations require that any vehicle lessor receiving this recall notice must forward a copy of this notice to the lessee within 10 days.

If you need help:

If, after contacting your dealership, you have questions or concerns which the dealership is unable to answer, please write to:

Yamaha Motor Corporation, U.S.A.
Customer Relations Department
P.O. Box 6555
Cypress CA 90630
or call 1-800-962-7926.

If, after contacting Yamaha Customer Relations, you are still not satisfied that we have done our best to remedy the situation without charge and within a reasonable time, you may submit a written complaint to the Administrator, National Highway Traffic Safety Administration, 1200 New Jersey Avenue, SE., Washington, DC 20590; or call the Auto Safety Hotline at 1-888-327-4236 (TTY: 1-800-424-9153); or go to <http://www.safercar.gov>.

If you no longer own this Yamaha:

If you have sold your motorcycle to another party, please call us toll-free at 1-800-962-7926 with the name and address of the new owner, along with the serial number shown to the right of your name and address above.

We're sorry to cause you any inconvenience, but we are sincerely concerned about your safety and continued satisfaction with our products. Thank you for giving your attention to this important matter.

Sincerely,
Customer Support Group
Yamaha Motor Corporation, U.S.A.