

Campaign No. 2011100006, November 2011

TO: ALL MERCEDES-BENZ CENTERS

SUBJECT: **Model 906, Model Year 2011**  
**Check Rear Springs, Replace if Necessary**

This Recall Campaign has been initiated because Daimler AG (DAG) has determined that on certain Sprinter vehicles, the rear springs may not meet the material standards requirements. The supplier rolled the spring eye out of tolerance on a limited number of parts in its production. In order to correct the diameter of the spring eye, the supplier pressed these springs under cold conditions. As a result, this may have caused hydrogen embrittlement within the material which could potentially lead to a crack of the spring eye over time. This could lead to an increased risk of a crash. DVUSA therefore has initiated a recall of all potentially affected vehicles described above. An authorized Freightliner or Mercedes-Benz Sprinter dealer will remedy this condition by checking an identification mark on the rear springs and replacing the rear springs if necessary.

Prior to performing this Recall Campaign:

- Please check VMI to determine if the vehicle is involved in the Campaign and if it has been previously repaired.
- Please review the entire Recall Campaign bulletin and follow the repair procedure exactly as described.

Please note that Recall and Service Campaigns **do not expire** and may also be performed on a vehicle with a vehicle status indicator.

Approximately 50 vehicles are affected.

Order No. V-RC-2011100006

This bulletin has been created and maintained in accordance with MBUSA-SLP S423QH001, Document and Data Control, and MBUSA-SLP S424HH001, Control of Quality Records.

## Procedure

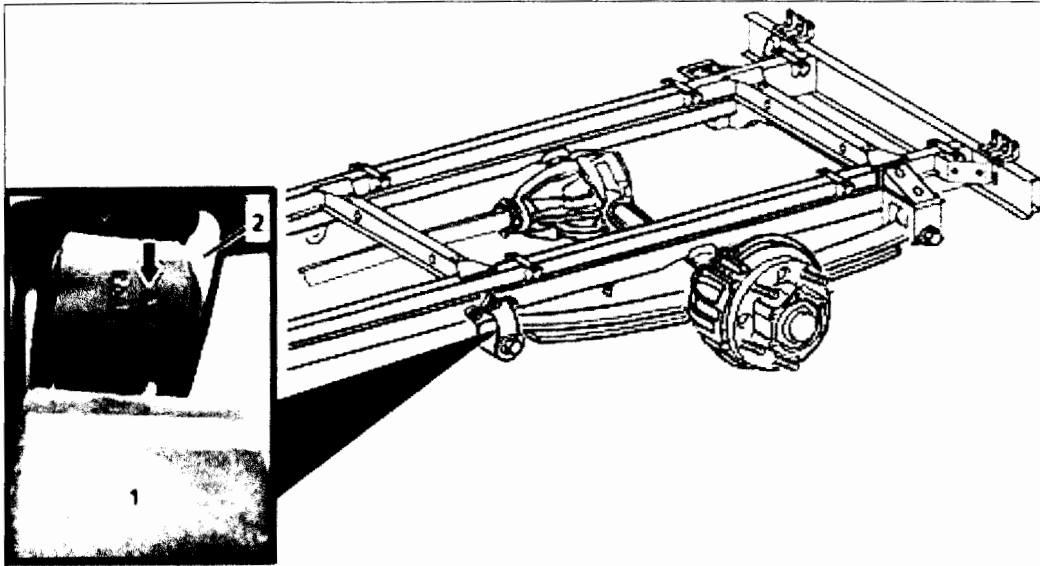

Figure 1

1. Check if batch number (arrow, Figure 1) is stamped on top of the front mounting eye (1, Figure 1) of rear axle spring using a mirror (2) then repeat inspection on opposite side:
  - If batch number stamped on **either the left or right** spring is **NOT**: SIAAA7 (on none of the springs), Procedure is complete.
  - If batch number stamped on **either the left or right** spring is: SIAAA7 (on one of the springs) proceed to step 2.
2. Replace **both** rear springs; refer to WIS; AR32.20-D-0230H.

**Note** (regarding above WIS instructions):

- For equipment referenced in step 2 please refer to MBUSA SSEP on-line equipment catalog.
- Step 10 is not claimable as part of this campaign. If replacement is necessary, check coverage prior to submitting under warranty.
- Disconnect shock absorber from lower mount to allow enough clearance to remove springs. Reinstall in reverse order, install new lock nut and torque nut to 106 Nm.

## Primary Parts Information

Qty.	Part Name	Part Number	Estimated Replacement Rate
2	Eye bolt/shackle nut	N000000 005426	80%
2	Shock absorber nut	N000000 003277	
1	Rear axle spring kit The kit includes the following parts below (do <b>not</b> order these parts separately, they are included in the above kit)	Q AP10119 05	
2	Rear Spring	A906 320 02 06	Part of kit do not order
8	U-bolt nut	A000 990 00 59	
4	Eye bolt/shackle nut	N000000 005426	

**Note:**

**You must order all Primary Parts to complete this repair.**

**Note:**

- Please be aware that only the part number(s) referenced in the Campaign Bulletin is/are approved for use to repair the vehicle. Repairs performed using any other part(s) will not have been performed in accordance with the campaign. Accordingly, warranty claims submitted with reference to an improper part number(s) will be denied.
- The following allowable labor operation should be used when submitting a warranty claim for this repair:

**Warranty Information****Repair 1**

**Operation:** Check rear axle springs (02 7630)

Damage Code	Operation Number	Labor Time (hrs.)	Model Indicator(s)
32 902 85 8	02 7630	0.3	Not Available <sup>1)</sup>

<sup>1)</sup> Use vehicle VIN when submitting warranty claim

**Repair 2**

**Operation:** Check rear axle springs (02 7630)  
Replace 2 rear axle springs (02 7632)

Damage Code	Operation Number	Labor Time (hrs.)	Model Indicator(s)
32 902 85 7	02 7630	0.3	Not Available <sup>1)</sup>
	02 7632	0.9	

<sup>1)</sup> Use vehicle VIN when submitting warranty claim

**NOTE REGARDING CUSTOMER REIMBURSEMENT**

Reimbursement to customers for repairs performed prior to this recall:

If the customer already paid to have this recall campaign condition repaired and provides adequate documentation to support their claim of a non-warranty repair of this item, they may be eligible to receive reimbursement.

Requests for reimbursement may include parts, labor, fees and taxes.

Reimbursement is limited to the amount the replacement of the right and left rear springs would have cost if completed by an authorized Mercedes-Benz dealer under this campaign. Submit a warranty claim, utilizing Damage Code 32 902 85 8 as a sublet, utilizing the sublet code of "SUB." Sublet repairs require dealer text as stated in the Warranty Policies and Procedures Manual. Repair date should be the date that the customer paid for the repair.

**Note:**

Please note the claim submitted for customer reimbursement will **not** close the campaign (if still open). If the customer is still in possession of the vehicle with an open campaign, please arrange to close the campaign in the usual manner as described in this bulletin.