



**Volvo Cars of North America, LLC**

1 Volvo Drive  
P.O. Box 914  
Rockleigh, NJ 07647  
Phone: 201-768-7300  
[www.volvocars.us](http://www.volvocars.us)

Product Safety & Compliance

**\*\*\*\*\* IMPORTANT VEHICLE RECALL NOTICE \*\*\*\*\***

DATE: June 24, 2011

TO: All U.S. and Canadian Volvo Retailers

RE: Volvo Recall 245  
Certain Model Year 2012 S60T5 Vehicles

**The sale or lease of defective or non-compliant motor vehicles or equipment is prohibited by law. Vehicles in retailer inventory must be remedied prior to sale. Repair information is attached to this communication.**

Volvo Cars of North America, LLC (Volvo) has decided to conduct a voluntary safety recall on certain model year 2012 S60T5 vehicles.

The male part of the fuel line quick connector end was produced with dimensions out of specification, leading to excessive assembly force on the female connector assembly and the possibility that the locking function may not be engaged.

If a vehicle exhibits this condition, the fuel line quick connector may detach and the engine may stall, increasing the risk of a crash. The customer may also notice a fuel smell and leakage. A fuel leak in the presence of an ignition source could result in a fire.

The corrective action will be to replace the fuel lines per TJ 24868.

This recall affects 442 vehicles in the U.S., 27 in Canada and 6 in Puerto Rico.

**OWNER NOTIFICATION**

Owner notification is scheduled to begin in June.

## **RETAILER RESPONSIBILITIES**

Retailers must perform this recall campaign on eligible vehicles regardless of miles/kilometers or vehicle age. All work performed under this recall is free of charge to the owner.

In the event that a customer does not have a notification letter, the owner is not to be refused the work. Your regional representative will follow up to ensure that this recall campaign is proceeding smoothly.

A complete description of the recall campaign requirements and claim submission procedures is below. It is the retailer's responsibility to review the details provided in the materials listed below with all involved personnel.

- Service Manager Bulletin
- Technical Journal
- Parts Bulletin

Your cooperation in completing this important recall is greatly appreciated.

Drive Safely,

A handwritten signature in blue ink, appearing to read "A. Kopstein".

Adam Kopstein  
Manager, Product Safety and Compliance  
201-768-7300 ext# 7908  
akopstei@volvocars.com

<h1 style="margin: 0;">VOLVO</h1> <h2 style="margin: 0;">Service Manager Bulletin</h2>				TITLE:		GROUP:	NO:	
				Recall 245: Replace Fuel Lines		23	245	
				Model Year 2012 S60T5		ISSUING DEPARTMENT:		
						Warranty		
				REFERENCE BULLETINS:		DATE:		
				TJ 24868, PB 23-245		YEAR	MONTH	DAY
Service Personnel: read and initial.	SERVICE MANAGER	SERVICE WRITER	WARRANTY ADMINISTRATOR			2011	06	24
						Page 1 of 2		

- A. RECALL 245 DESCRIPTION
- B. VEHICLES INVOLVED
- C. PARTS INFORMATION/PARTS RETURN
- D. OWNER NOTIFICATION
- E. VEHICLES IN RETAILER INVENTORY
- F. RETAILER RESPONSIBILITY
- G. TECHNICIAN COMPETENCY REQUIREMENT
- H. CAMPAIGN REIMBURSEMENT PROCEDURES

**A. RECALL 245 DESCRIPTION**

Volvo Cars of North America, LLC (Volvo) has decided to conduct a voluntary safety recall on certain model year 2012 S60T5 vehicles.

The male part of the fuel line quick connector end was produced with dimensions out of specification, leading to excessive assembly force on the female connector assembly and the possibility that the locking function may not be engaged.

If a vehicle exhibits this condition, the fuel line quick connector may detach and the engine may stall, increasing the risk of a crash. The customer may also notice a fuel smell and leakage. A fuel leak in the presence of an ignition source could result in a fire.

The corrective action will be to replace the fuel lines per TJ 24868.

This recall affects 442 vehicles in the U.S., 27 in Canada and 6 in Puerto Rico.

**B. VEHICLES INVOLVED**

**NOTE: RETAILERS MUST CONFIRM VEHICLE ELIGIBILITY PRIOR TO BEGINNING THIS RECALL REPAIR.**

Vehicle eligibility must be confirmed:

- Inquire in VRC<sup>2</sup> - Vehicle Warranty where the message "RECALL 245 - Replace Fuel Lines (R29218)" will appear for eligible vehicles.

"Fixed Right — First Time"



All vehicles should be checked for any other incomplete recalls or service campaigns or service upgrades. All open Recall, Service Campaign or Service Action repairs should be completed.

#### **RETAILER VEHICLE CAMPAIGN LIST**

The "Unperformed Recall Report" will be posted on VRC<sup>2</sup> in the Reports Menu under the Service Tab. This report lists all affected vehicles that are on record as retailed/serviced or currently in stock at your facility with incomplete recalls and service campaigns, and is updated monthly.

#### **C. PARTS INFORMATION / PARTS RETURN**

Please refer to Parts Bulletin 23-245.

##### **PARTS RETURN**

Parts are not required to be returned for repairs done in accordance with this recall.

#### **D. OWNER NOTIFICATION**

Owner notification is scheduled to begin in June.

#### **E. VEHICLES IN RETAILER INVENTORY**

All vehicles in retailer inventory and qualifying for this recall must be repaired prior to a customer taking possession of the vehicle.

#### **F. RETAILER RESPONSIBILITY**

Retailers are to perform this recall on eligible vehicles regardless of mileage/kilometers or vehicle age. The repairs included in Recall 245 are free of charge to the owner. If a customer presents a recall or service campaign letter for a vehicle that is not found via the VRC<sup>2</sup> inquiry function, please verify that the letter applies to the customer's vehicle and call the Warranty Assistance Desk at 1-800-807-7712 for instructions. If the Warranty Assistance Desk verifies that the vehicle qualifies for the Recall or Service Campaign, please perform the repair and place the recall or service campaign letter in the customer's file. Under no circumstances should a customer be denied the required service without a confirmation from VCNA/VCCC.

#### **G. TECHNICIAN COMPETENCY REQUIREMENT**

The technician competency requirement for this campaign repair is: Level 2 Quality Tech.

#### **H. CAMPAIGN REIMBURSEMENT PROCEDURES (LONG FORM APPLICATION)**

Labor reimbursement allowance is effective at time of release and may change in the future.

**Claim Type:** R29218  
**Cause Code:** 02  
**CSC Code:** XW  
**Main OP:** 23598

<u>Operation Number</u>	<u>Repair Description</u>	<u>Qty</u>	<u>Labor Time</u>
23598	Replace Fuel Lines	1	2.1 Hrs



# Parts Bulletin

SUBJECT <b>Recall 245: Replace Fuel Lines Model Year 2012 S60T5</b>				GROUP <b>23</b>		NO <b>245</b>	
				COPY TO / CIRCULATIONS (PLEASE INITIAL)			
GENERAL MGR	PARTS MGR	SERVICE MGR	SALES MGR	DATE	YEAR	MONTH	DAY
					<b>2011</b>	<b>06</b>	<b>24</b>

Reference Bulletins: TJ 24868  
SMB 23-245

Volvo Cars of North America, LLC (Volvo) has decided to conduct a voluntary safety recall on certain model year 2012 S60T5 vehicles.

The male part of the fuel line quick connector end was produced with dimensions out of specification, leading to excessive assembly force on the female connector assembly and the possibility that the locking function may not be engaged.

If a vehicle exhibits this condition, the fuel line quick connector may detach and the engine may stall, increasing the risk of a crash. The customer may also notice a fuel smell and leakage. A fuel leak in the presence of an ignition source could result in a fire.

The corrective action will be to replace the fuel lines per TJ 24868.

**This recall affects 442 vehicles in the U.S., 27 in Canada and 6 in Puerto Rico. Due to the low volume of cars affected, there will not be an allocation for this recall. Please only order these parts as needed.**

The following part numbers apply:

Part Number	Description	Qty
30751368	Delivery Pipe	1
31336649	Plastic Pipe	1

**"Fixed Right — First Time"**



Printed in USA on recycled paper containing a minimum of 50% wastepaper and 10% post-consumer waste.

© 2011 VOLVO CARS OF NORTH AMERICA, LLC



## TIE - Technical Journal

**Title** Recall 245: Fuel pipe end connector

**Ref No** US24868.1.2 en-GB

**Issuer** -

**Partner** 3 US 7510 Volvo Cars North America

**Func Group** 2330 **Func Desc** fuel pump and strainer

**Status** Released

**Status Date** 2011-06-24

**Issue Date** 2011-06-13

**Reference** SMB 23-245, PB 23-245

### Attachment

File Name	File Size
Attachment TJ 24868.pdf	1.0809 MB

### Vehicle Type

Type	Eng	Eng Desc	Sales	Body	Gear	Steer	Model Year	Plant	Chassis range	Struc Week Range
134	62	B5254T5					2012 -2012		0030902 -0032474	0 -0

### CSC

Code	Description
XW	Service action/Recall/Service action/Recall

### DTC

#### Text

**CSC = Customer Symptom Code**

**DTC = Diagnostic Trouble Code**

**Note! If using a printed copy of this Technical Journal, first check for the latest online version.**

#### DESCRIPTION:

Volvo Cars of North America, LLC (Volvo) has decided to conduct a voluntary safety recall on certain model year 2012 S60T5 vehicles.

The male part of the fuel line quick connector end was produced with dimensions out of specification, leading to excessive assembly force on the female connector assembly and the possibility that the locking function may not be engaged.

If a vehicle exhibits this condition, the fuel line quick connector may detach and the engine may stall, increasing the risk of a crash. The customer may also notice a fuel smell and leakage. A fuel leak in the presence of an ignition source could result in a fire.

#### SERVICE:

The corrective action is to replace the fuel lines according to the attached instructions.

## Volvo Car Customer Service

TJ Instruction

TJ No 24868

Date

June-11

Issue 0G

Title	Fuel pipe end connector
-------	-------------------------

### Materials

Description	Qty.	Part No.
Delivery pipe	1	30751368
Plastic pipe	1	31336649

### Special tools

Description	Part No.
Removal tool	999 7298

**VOLVO**

### Depressurizing

Perform depressurizing fuel system, refer to:  
Cleaning, Inspection and Adjustment  
2 - Engine with mountings and equipment  
23 - Fuel system  
234 - fuel tank, fuel lines, evaporator system

### Removal

Remove the fuel rail, refer to:  
Removal, replacement and installation  
2 - Engine with mountings and equipment  
23 - Fuel system  
237 - injector and delivery pipe

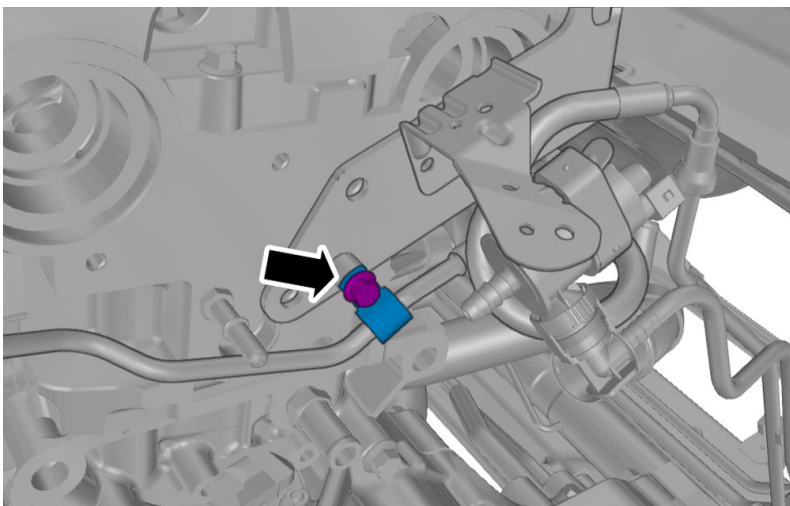
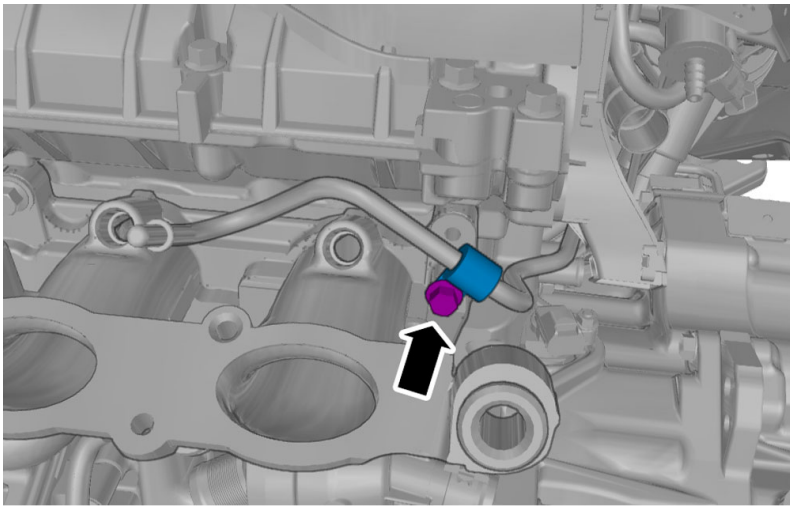



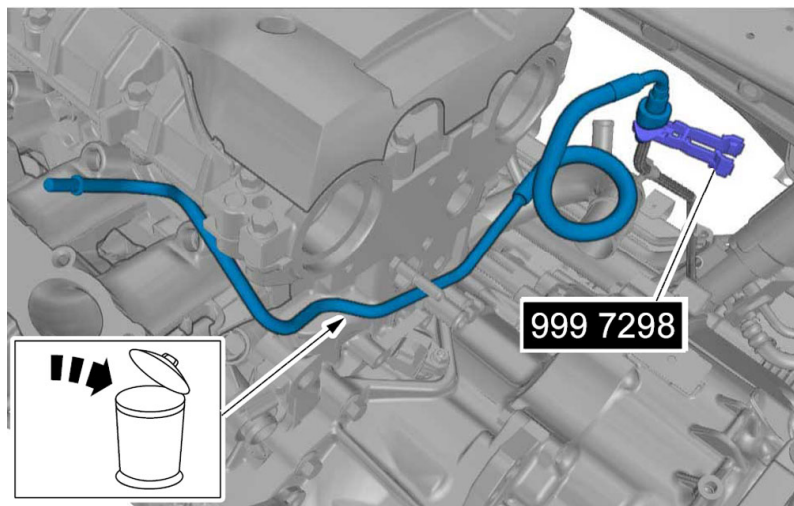

**Warning!** Be prepared to collect escaping fluid.

Special Tool: T9997298, REMOVAL TOOL

Follow instructions for lifting points body frame, refer to:

Specifications, mechanical

8 - Body and interior

81 - Body frame

810 - general

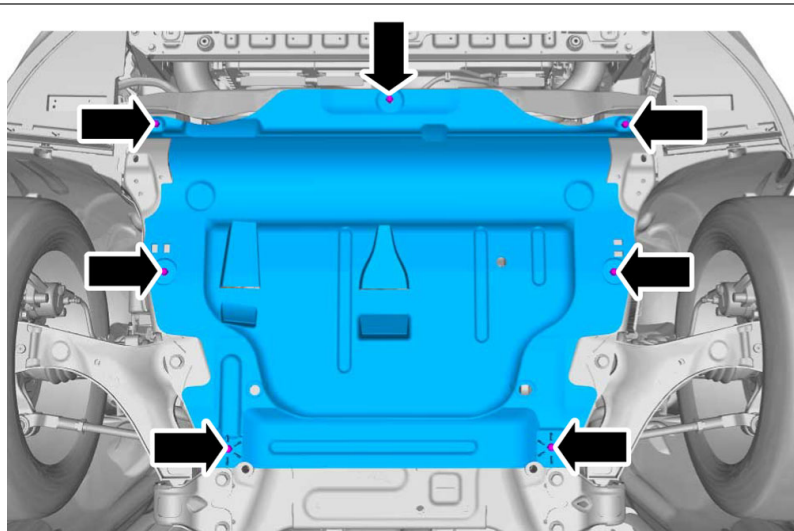

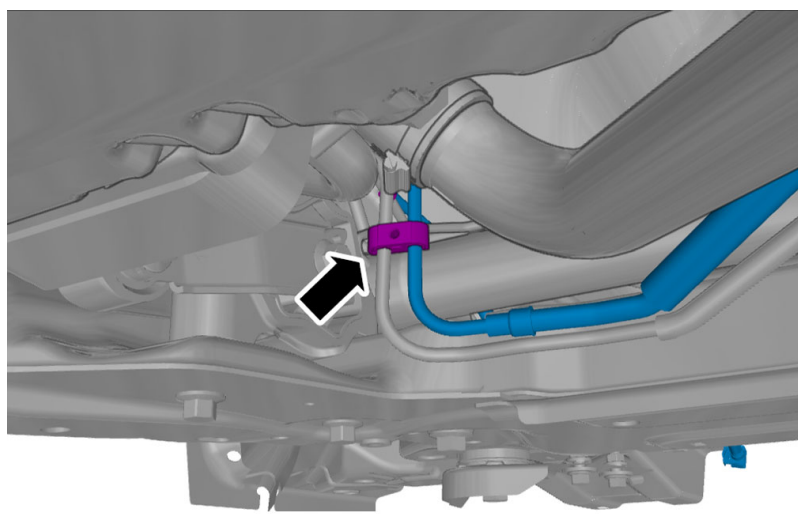
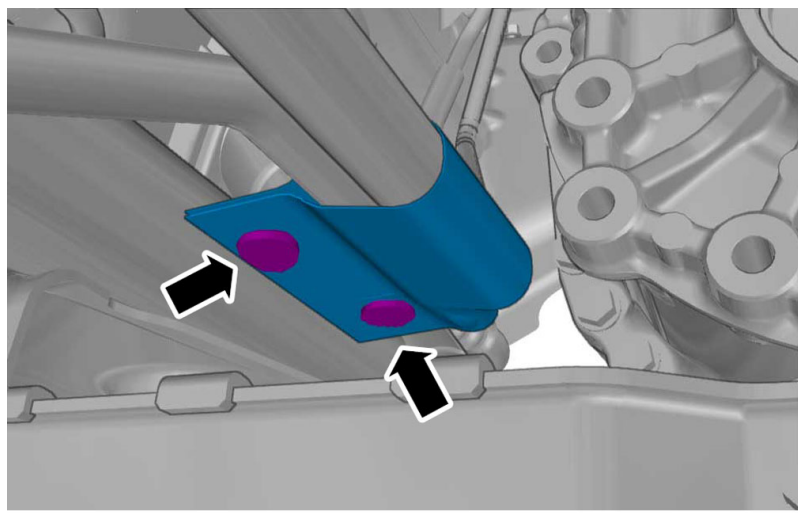
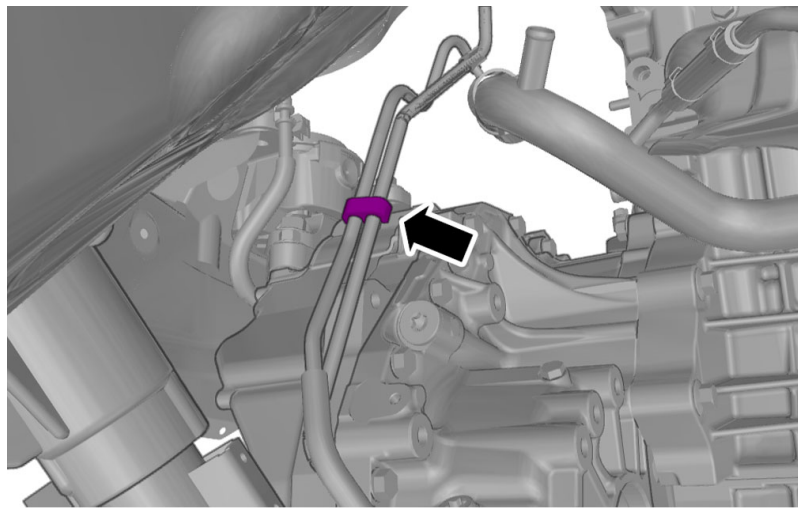

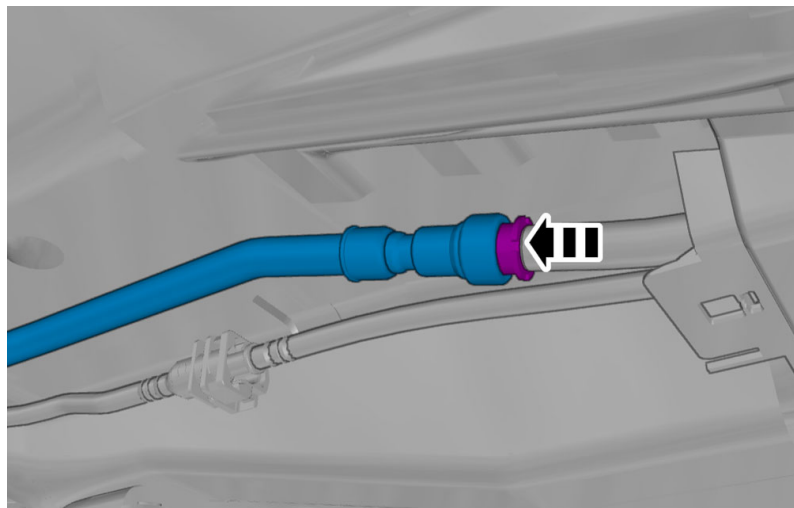
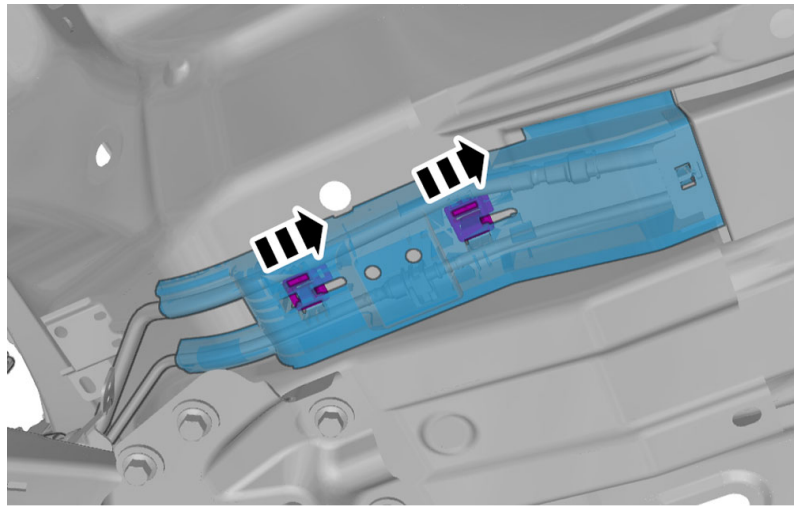

**Warning!** Be prepared to collect escaping fluid.

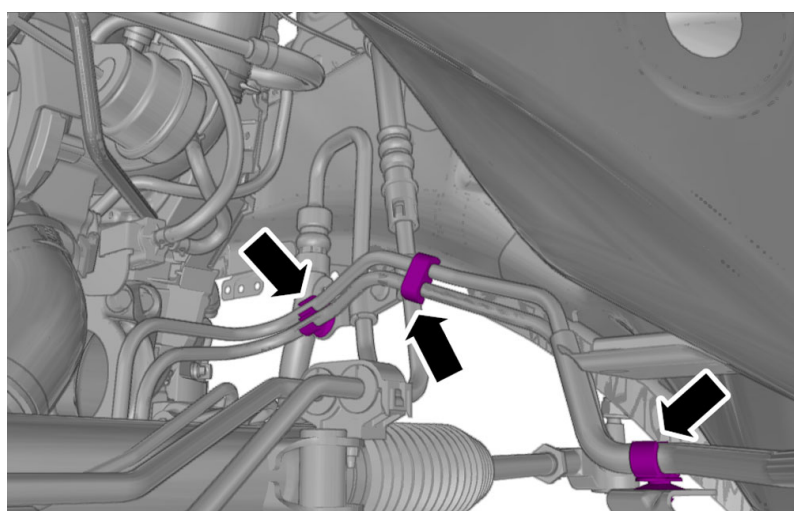

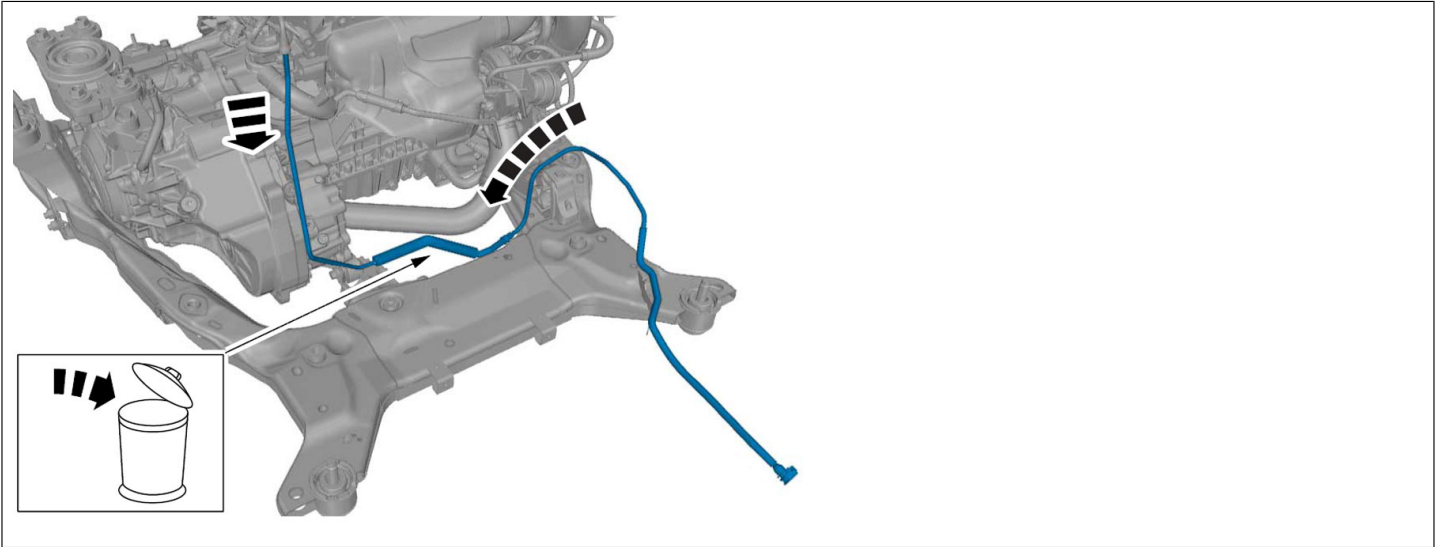

**Installation**

To install, reverse the removal procedure.



**Volvo Cars of North America, LLC**

1 Volvo Drive  
P.O. Box 914  
Rockleigh, NJ 07647  
Phone: 201-768-7300  
[www.volvocars.us](http://www.volvocars.us)

**IMPORTANT RECALL NOTICE**

June 24, 2011

Dear Volvo Owner:

This notice is sent to you in accordance with the requirements of the National Traffic and Motor Vehicle Safety Act.

Volvo Cars of North America, LLC (Volvo) has decided to conduct a voluntary safety recall on certain model year 2012 S60T5 vehicles.

***The reason for Recall 245:***

Volvo has identified that the male part of the fuel line quick connector end was produced with dimensions out of specification, leading to excessive assembly force on the female connector assembly and the possibility that the locking function may not be engaged.

If a vehicle exhibits this condition, the fuel line quick connector may detach and the engine may stall, increasing the risk of a crash. The driver may also notice a fuel smell and leakage. A fuel leak in the presence of an ignition source could result in a fire.

The corrective action will be to replace the fuel lines.

***What you need to do:***

Please contact your authorized Volvo retailer for an appointment. This procedure will be completed at no cost and can take up to 3 hours to complete; **however, due to service scheduling and parts availability, the time your Volvo retailer requires to service your vehicle may vary.**

If you had this repair performed before you received this letter, you may be eligible to receive reimbursement for the cost of obtaining a pre-notification remedy of the problem associated with this recall. For more information please refer to the Volvo Customer Care Center contact information in this letter.

***Please contact:***

If you have any questions, please contact your Volvo retailer. If your retailer is unable to answer your questions, please contact Volvo Customer Care Center at 1 Volvo Drive, P.O. Box 914, Rockleigh, NJ 07647 or phone 1-800-458-1552, Monday through Friday, 8:30 A.M. to 5:00 P.M. EST. You may also e-mail us at [customercare@volvoforlife.com](mailto:customercare@volvoforlife.com).

We have advised the National Highway Traffic Safety Administration (NHTSA) that we are conducting this recall. If you are unable to have this procedure performed without charge and within a reasonable period of time, you may contact the NHTSA Administrator at: National Highway Traffic Safety Administration, 1200 New Jersey Avenue, SE., Washington, DC 20590; or call the toll-free Vehicle Safety Hotline at 1-888-327-4236 (TTY: 1-800-424-9153); or go to <http://www.safercar.gov>.

Federal law requires that any vehicle lessor receiving this recall notice must forward a copy of this notice to the lessee within ten days. Lessor means a person or entity that is the owner, as reflected on the vehicle title, of any five or more leased vehicles.

Your safety and continued satisfaction with your Volvo and the Volvo organization are very important to us. We apologize for any inconvenience this may cause and we appreciate your cooperation in arranging to have this important service completed as quickly as possible.

Sincerely,

A handwritten signature in cursive script that reads "Mike Assainte".

Mike Assainte

Manager, Customer Support



**Volvo Cars of Canada Corp.**

175 Gordon Baker Road  
North York, ON, Canada M2H 2N7  
Telephone (416) 493-3700  
Facsimile (416) 496-0552  
[www.volvocanada.com](http://www.volvocanada.com)

June 2011

**IMPORTANT RECALL NOTICE**

Dear Volvo Owner:

This notice is sent to you in accordance with the requirements of the Motor Vehicle Safety Act.

Volvo Cars of North America, LLC (Volvo) has decided to conduct a voluntary safety recall on certain model year 2012 S60T5 vehicles.

***The reason for Recall 245:***

Volvo has identified that the male part of the fuel line quick connector end was produced with dimensions out of specification, leading to excessive assembly force on the female connector assembly and the possibility that the locking function may not be engaged.

If a vehicle exhibits this condition, the fuel line quick connector may detach and the engine may stall, increasing the risk of a crash. The driver may also notice a fuel smell and leakage. A fuel leak in the presence of an ignition source could result in a fire.

The corrective action will be to replace the fuel lines.

***What you need to do:***

Please contact your authorized Volvo retailer to schedule an appointment. This procedure will be completed at no cost and can take up to 3 hours to complete; **however, due to service scheduling and parts availability, the time your Volvo retailer requires to service your vehicle may vary.**

If you previously paid to have this corrective action performed, prior to the date on this letter, your authorized Volvo retailer will honor your receipt with a refund. Please contact your authorized Volvo retailer service department for details.

***Please contact:***

If you have any questions, please contact your authorized Volvo retailer. If your retailer is unable to answer your questions, please contact Volvo Customer Relations at 1-800-663-8255, Monday through Friday, 8:30 A.M. to 5:00 P.M. EST or by e-mail at [vlcust@volvocars.com](mailto:vlcust@volvocars.com). You may also write to us at 175 Gordon Baker Road, Toronto, Ont. M2H 2N7.

*Federal law requires that any vehicle lessor receiving this recall notice must forward a copy of this notice to the lessee within ten days. Lessor means a person or entity that is the owner, as reflected on the vehicle title, of any five or more leased vehicles.*

We have advised Transport Canada that we are conducting this recall.

Thank you for being a member of the Volvo family. We hope you will appreciate our efforts to continually provide you with updated information of importance to your safety and the quality of your Volvo vehicle.

Sincerely,

A handwritten signature in cursive script that reads "Carol Kitchen".

Carol Kitchen  
V.P. Customer Service





**La Compagnie des Automobiles  
Volvo du Canada**

175, chemin Gordon Baker  
North York (Ontario) Canada M2H 2N7  
Téléphone : 416-493-3700  
Télécopieur : 416-496-0552  
www.volvocanada.com

Juin 2011

**AVIS DE RAPPEL IMPORTANT**

Madame, Monsieur,

Cet avis vous est envoyé en conformité avec les exigences de la *Loi sur la sécurité automobile*.

Volvo Cars of North America, LLC (Volvo) a décidé de procéder à un rappel de sécurité volontaire sur certaines S60 T5 de l'année-modèle 2012.

***Raisons du rappel 245 :***

Volvo a déterminé que les dimensions de l'élément mâle du raccord rapide de canalisation à carburant ne sont pas conformes aux spécifications, ce qui peut exercer une pression excessive sur l'élément femelle du raccord et empêcher ainsi le verrouillage du raccord.

Dans un tel cas, il est possible que le raccord rapide de canalisation à carburant se détache et que le moteur cale, ce qui pourrait augmenter les risques d'accident. Le conducteur peut également remarquer une odeur de carburant ou des signes de fuite de carburant. Une fuite de carburant, en présence d'une source d'inflammation, risquerait de provoquer un incendie.

La mesure corrective sera de remplacer les canalisations à carburant.

***Ce que vous devez faire :***

Veillez communiquer avec votre concessionnaire Volvo autorisé pour prendre rendez-vous. La réparation sera effectuée gratuitement et devrait prendre jusqu'à 3 heures; **toutefois, compte tenu des rendez-vous d'entretien et de la disponibilité des pièces, votre concessionnaire Volvo peut avoir besoin de plus de temps.**

Si vous avez déjà payé pour faire effectuer cette réparation, avant la date figurant sur la présente lettre, votre concessionnaire Volvo autorisé vous remboursera sur présentation de votre reçu. Veuillez communiquer avec le service d'entretien de votre concessionnaire Volvo autorisé pour de plus amples renseignements.

***Veillez communiquer :***

Pour en savoir plus, veuillez communiquer avec votre concessionnaire Volvo autorisé. Si votre concessionnaire n'est pas en mesure de répondre à vos questions, veuillez communiquer avec le Service à la clientèle de Volvo au 1-800-663-8255 (du lundi au vendredi – de 8 h 30 à 17 h HNE) ou envoyer un courriel à [vlcust@volvocars.com](mailto:vlcust@volvocars.com). Vous pouvez également nous écrire à l'adresse suivante : 175, chemin Gordon Baker, Toronto (Ontario) M2H 2N7.

*La loi fédérale exige que tout donneur à bail de véhicule concerné par cet avis de rappel remette dans un délai de dix jours une copie de cet avis au preneur à bail. Par donneur à bail, on entend toute personne ou toute entité qui agit en tant que propriétaire, comme il est indiqué sur le titre du véhicule, de cinq véhicules ou plus faisant l'objet d'un bail.*

Nous avons informé Transports Canada que nous mettons en place ce rappel.

Nous vous remercions de faire partie de la famille Volvo. Nous espérons que vous apprécierez nos efforts continus pour vous fournir des renseignements à jour sur des éléments importants pour votre sécurité et pour la qualité de votre véhicule Volvo.

Veillez agréer, Madame, Monsieur, mes salutations distinguées.



Carol Kitchen  
Vice-présidente, Service à la clientèle