



# TECHNICAL SERVICE BULLETIN

THE NEW AMERICAN MOTORCYCLE™

## Victory Motorcycle

Bulletin Number:

V-11-01

V-11-01A

Date: 06/13/2011

Model Years:

2011

Safety Bulletin  **Safety Recall**  Service Bulletin  Service Alert Fax  Production Update Kit

Distribution:  Owner / Principal  Service Manager  Sales Manager  Parts Manager  Technicians

*This Service Bulletin is located at [www.polarisdealers.com](http://www.polarisdealers.com)*



-Confidential and Proprietary-

### SUBJECT: 2011 Cross Country Handlebar Riser Assembly Inspection / Replacement

#### PURPOSE:

Victory has determined that some Model Year 2011 Victory Cross Country handlebar riser / clamp assemblies may be defective. The defective handlebar riser / clamp assemblies do not provide sufficient clamping force and may allow the handlebars to rotate in the riser assembly, increasing the risk of an operator losing control which could result in a vehicle crash.

#### AFFECTED MODELS:

Model(s) Affected	Model Numbers	Vehicle Identification Number Range
2011 Victory Cross Country	V11DB36EA; V11DB36EB; V11DB36ER; V11DB36NA; V11DB36NAA; V11DB36NAC; V11DB36NB; V11DB36NBA; V11DB36NBC V11DB36NR; V11DB36NRA; V11DB36NRC V11DC36EN; V11DC36NN; V11DC36NNA V11DC36NNC; V11EB36EA; V11EB36EC; V11EB36EY	Vehicles built between 01/01/11 – 04/09/11 <b>Reference 'Unit Inquiry' on the dealer website to lookup affected VIN's.</b>

#### WHAT YOUR DEALERSHIP SHOULD DO:

1. Perform the INSPECTION PROCEDURE outlined in this bulletin to determine if handlebar riser / clamp assemblies are defective.
2. If the vehicle passes inspection, file a warranty claim for bulletin V-11-01 immediately following completion.
3. **If the INSPECTION PROCEDURE reveals defective handlebar riser / clamp assemblies dealers should;**
  - Replace handlebar riser / clamp assemblies following the REPLACEMENT PROCEDURE outlined in this bulletin.
  - File a warranty claim for bulletin V-11-01A immediately after completion of this bulletin.
4. Dealer must submit an ASK Polaris case via **Warranty Claim & Warranty Parts Return Question** and provide the following information;
  - Warranty Claim Number for bulletin V-11-01A.
  - The words "V-11-01A Repair Order" must be written in the **Question** field.
  - A copy of your Dealership's Customer Repair Order must be attached to the ASK Polaris case.

**NOTE: Polaris will be working with an outside company, Centro Inspection Agency, to assist with vehicle field inspection audits when necessary.**

## CUSTOMER NOTIFICATION:

A customer notification letter will be sent to all registered owners of motorcycles affected by this bulletin. An example of the U.S. letter is shown on page 8. In addition to the notification letter sent by Victory Motorcycles, dealers are required to notify owners of motorcycles sold by their dealership, and to make arrangements to perform this bulletin repair immediately.

## INSPECTION PROCEDURE:

### Tools Required for Inspection:

- (QTY.2) Soft tie straps with a minimum 50 lbs. load rating (commercially available).
- (QTY.2) Spring-scale with a 50 lbs. weight rating (commercially available).

1. Support motorcycle securely in an upright position with the front wheel clamped in a wheel vise.

2. Using a grease pen, mark the handlebar at the parting line between the riser and riser clamp (see Figure 1). The mark will be used to determine if any handlebar rotation has occurred following the inspection.

3. Securely attach tie straps around center of left and right handgrips (see Figure 2).

4. Attach the spring scales to the tie straps (see Figure 2).

5. With one person on each side of the motorcycle, slowly apply an upward (vertical lifting) force until each scale individually reads 50 lbs. (Force totaling 100 lbs. on the handlebar assembly).

**THE HANDLEBAR ASSEMBLY SHOULD NOT ROTATE WITHIN THE RISERS. IF ANY MOVEMENT IS DETECTED THE RISER / CLAMP ASSEMBLIES MUST BE REPLACED (PROCEED TO REPLACEMENT PROCEDURE).**

6. If no rotation is detected, the replacement procedure is not necessary. File a warranty claim for V-11-01 (Inspection).

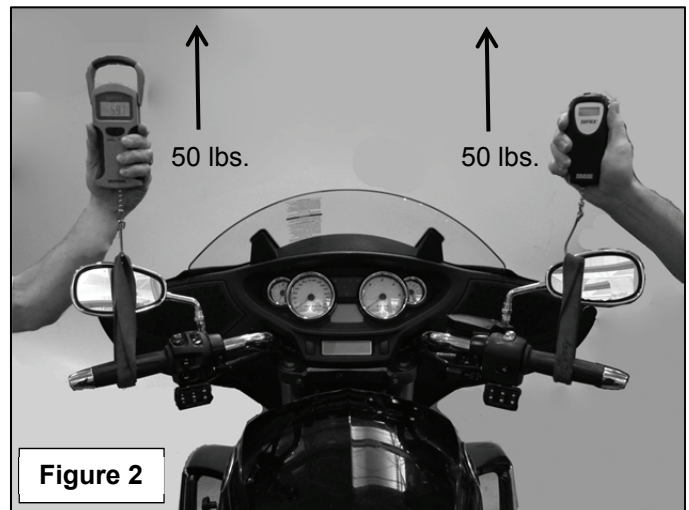
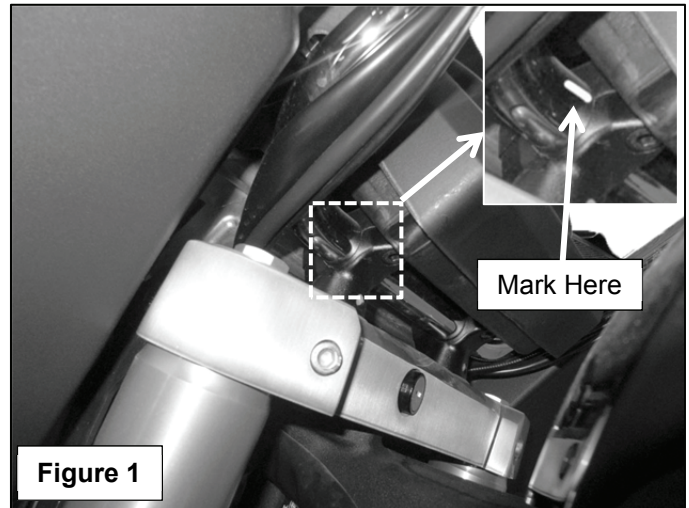

## REPLACEMENT PROCEDURE:

1. Remove head light bezel (see Figure 1).

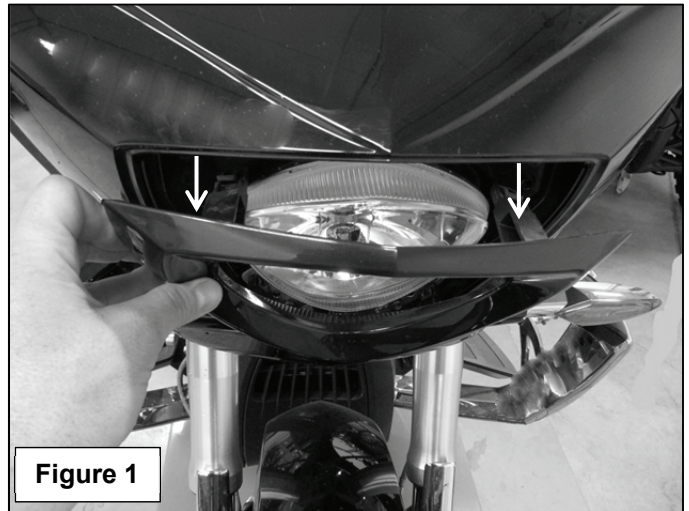

2. Remove screws (4) securing head light assembly to front fairing (see Figure 2), disconnect electrical connectors and remove head light.

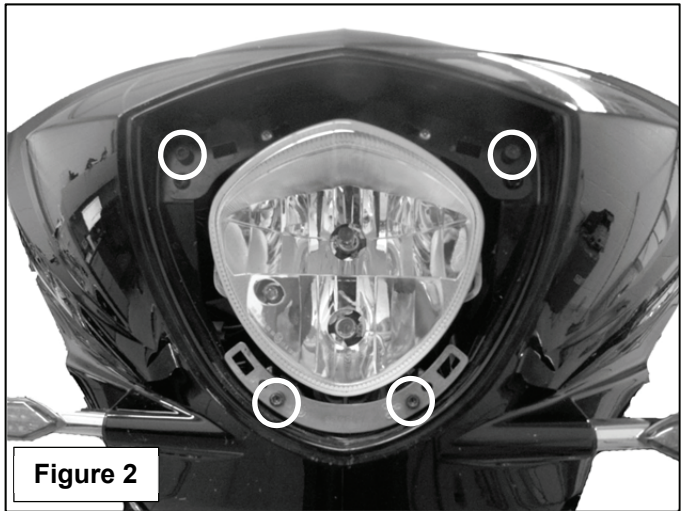

3. Using body tool (PV-49955), remove left and right speaker grills from front fairing as shown (see Figure 3).

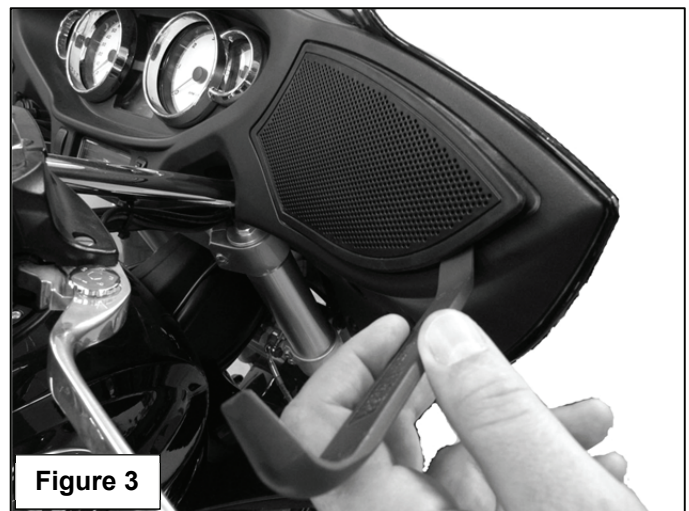

4. Remove screws (8) securing outer fairing shell to fairing subassembly (see Figure 4). Disconnect turn signal connectors and remove outer fairing shell.

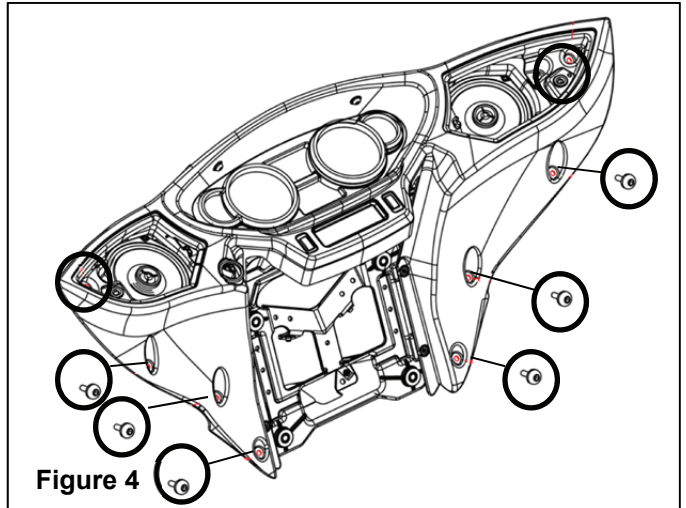

5. Remove bolts (4) securing fairing subassembly to chassis (see Figure 5).

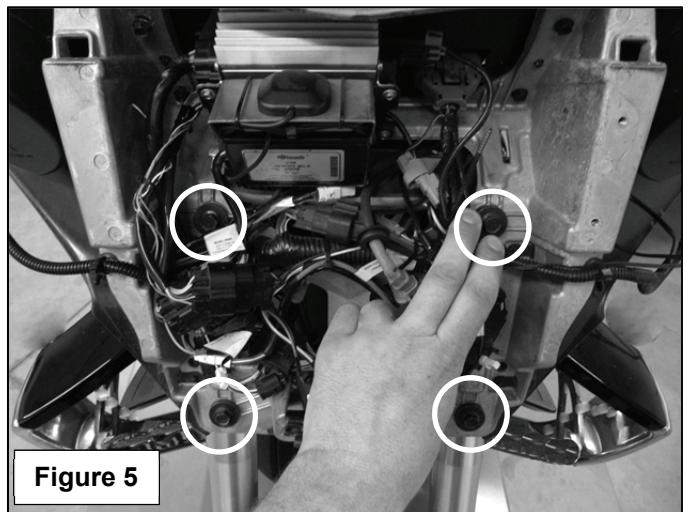

6. Lift subassembly and tilt forward to gain access to handlebar risers and clamp bolts (see Figure 6).

**CAUTION:** Wires may become stretched, kinked or broken if extreme care is not taken while maneuvering subassembly.

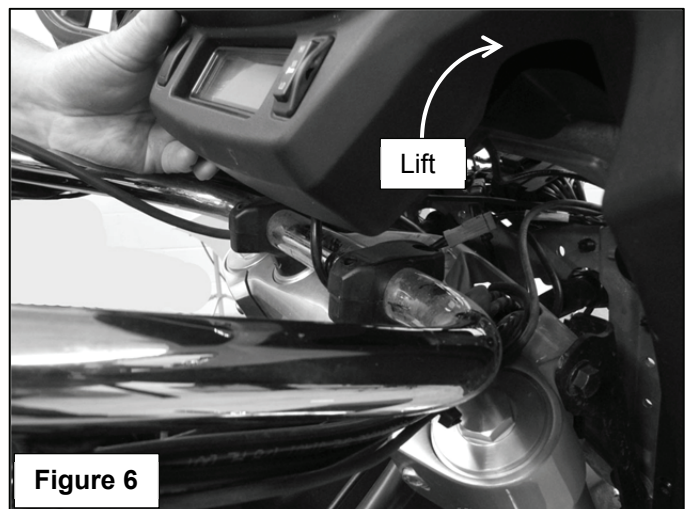

7. Place a protective cover over the fuel tank. While supporting the handlebar assembly, remove the handlebar clamp bolts (see Figure 7).

**IMPORTANT:** If the handlebar assembly is not properly supported, the handlebar may drop down onto the fuel tank when the clamp bolts are loosened. If the fuel tank is not sufficiently protected, damage may occur.

8. Lift the handlebar assembly out of risers and move forward until clear of risers (see Figure 8).

9. Loosen set screws securing riser bolts and remove bolts (1 each) securing handlebar risers to upper triple clamp (see Figure 8).

10. Remove risers.

11. Loosely install new handlebar risers. Place the handlebar assembly into risers to maintain riser alignment. Torque riser bolts to **40 ft-lbs. (54 Nm)**.

12. Tighten set screw (see Figure 8) until it stops against riser bolt then tighten an additional **90° (1/4 turn)**.

13. Loosely install new riser clamps and clamp bolts, so the handlebar can rotate freely in risers.

14. Align the index mark on the handlebar with the parting in the riser clamp (see Figure 9). Starting with the front bolts, torque riser clamp bolts to **22 ft-lbs. (30 Nm)**.

15. Reinstall fairing subassembly bolts (see Figure 5). Torque bolts to **19 ft-lbs. (26 Nm)**.

16. Lift outer fairing shell into position and reconnect turn signals (see Figure 4). Torque screws to **36 in-lbs. (4 Nm)**.

17. Reinstall speaker grills, head light assembly and head light bezel.

18. Verify the following:

- Handlebars turn freely from left to right.
- Turn signals operate properly.
- High-beam and Low-beam head lights operate correctly.
- Side mirrors are adjusted correctly.

19. File a warranty claim for V-11-01A and submit an ASK Polaris case via **Warranty Claim & Warranty Parts Return Question** and provide the following information;

- Warranty Claim Number for bulletin V-11-01A.
- The words "V-11-01A Repair Order" must be written in the **Question** field.
- A copy of your Dealership's Customer Repair Order must be attached to the ASK Polaris case.

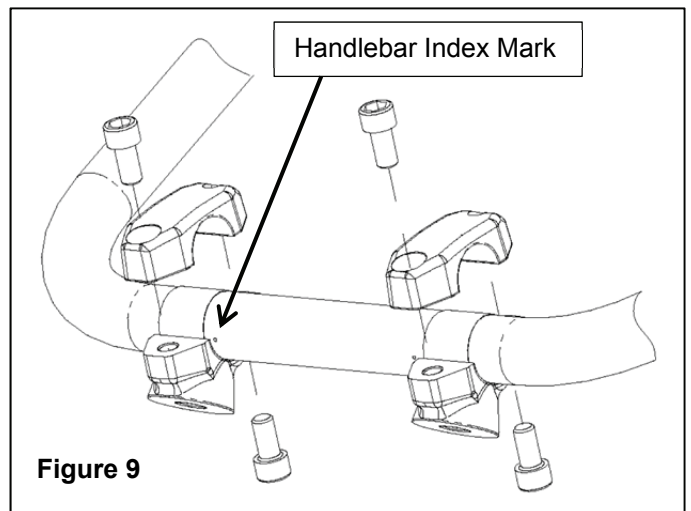
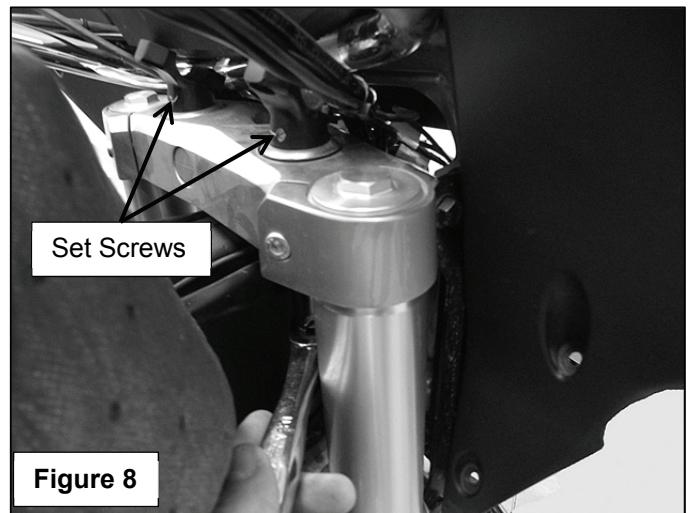
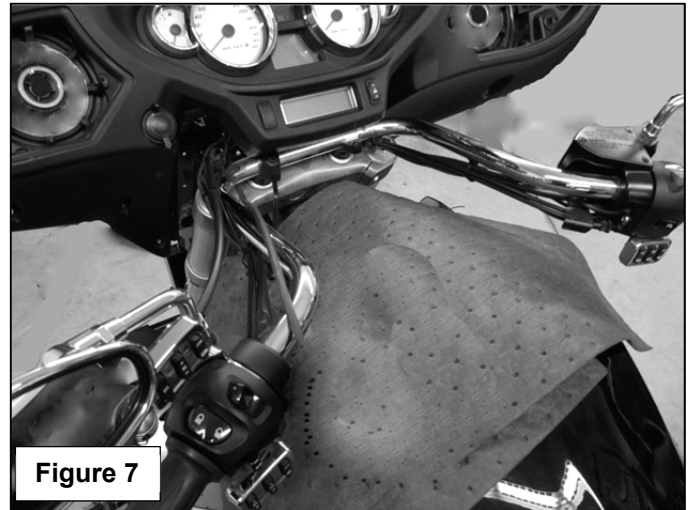

## PARTS INFORMATION:

### V-11-01 (INSPECTION)

PART NUMBER / DESCRIPTION	7170107 (QTY. 1) – Service Bulletin Completion Decal
PARTS AVAILABILITY	Available to Order
DIRECT-SHIP FROM POLARIS?	No
TO BE ORDERED BY DEALER?	Yes

### V-11-01A (INSPECTION AND REPLACEMENT)

PART NUMBER / DESCRIPTION	5136703-468 (QTY. 2) - Handlebar Riser (Black) 5136704-468 (QTY. 2) - Handlebar Clamp (Black) 7519100 (QTY. 2) – Set Screw 7519044 (QTY. 2) – Riser Bolt 7517569 (QTY. 4) – Clamp Screw 7170107 (QTY. 1) – Service Bulletin Completion Decal
PARTS AVAILABILITY	Parts available to order on the week of 6/13/2011.
DIRECT-SHIP FROM POLARIS?	No
TO BE ORDERED BY DEALER?	Yes

## WARRANTY CLAIM INFORMATION:

A single group claim may be submitted listing the complete (17 digit) Vehicle Identification Number for machines with the same model number. File claim type **SB (Service Bulletin)**. DO NOT PUT MORE THAN ONE MODEL NUMBER ON A CLAIM.

SERVICE BULLETIN #	<b>V-11-01 (Inspection)</b>
CLAIM TYPE	SB (Service Bulletin)
LABOR ALLOWANCE	.2 Hrs. (12 minutes)
CLAIM PART NUMBERS	N/A - Auto Process Bulletin

SERVICE BULLETIN #	<b>V-11-01A (Inspection and Replacement)</b>
CLAIM TYPE	SB (Service Bulletin)
LABOR ALLOWANCE	1.4 Hrs. (1 hour :24 minutes) *Time includes inspection*
CLAIM PART NUMBERS	5136703-468 (QTY. 2) - Handlebar Riser (Black) 5136704-468 (QTY. 2) - Handlebar Clamp (Black) 7519100 (QTY. 2) – Set Screw 7519044 (QTY. 2) – Riser Bolt 7517569 (QTY. 4) – Clamp Screw 7170107 (QTY. 1) – Service Bulletin Completion Decal

## SERVICE BULLETIN COMPLETION DECAL:

A Service Bulletin Completion Decal must be completed for this bulletin repair. Place the decal on the unit as shown (inside LH side cover). If you require more decals, order them through normal Polaris parts ordering channels.

Sincerely,



Bridget McLennan,  
Warranty and Service Publications Manager

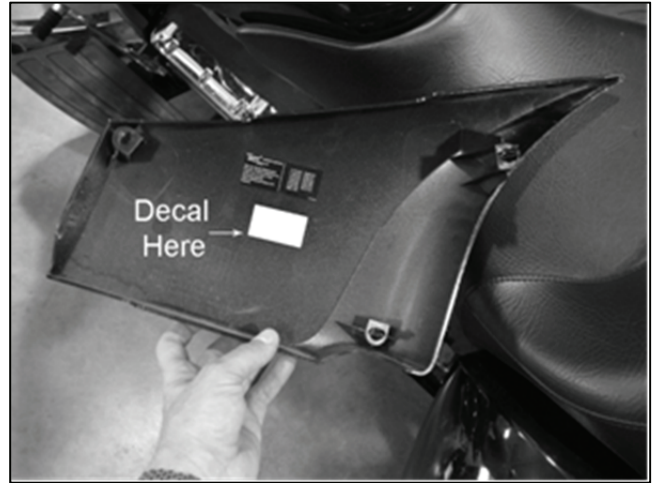

## EXAMPLE OF U.S. CONSUMER LETTER 11V-305 (2011-221 in Canada)



Victory Motorcycle Division  
of Polaris Industries Inc.  
2100 Highway 55  
Medina, MN 55430

### SAFETY RECALL NOTICE

Recall Campaign: 11V-305

**Subject: Handlebar Riser Assembly Inspection / Replacement**

**2011 Victory Cross Country™ models.**

**Reference: Safety Recall Bulletin V-11-01**

**PLEASE READ IMMEDIATELY**

Dear Victory Owner:

This notice is sent to you in accordance with the requirements of the National Traffic and Motor Vehicle Safety Act. The Victory Motorcycle Division of Polaris Industries Inc. has decided that a defect which relates to motor vehicle safety exists in some 2011 Victory Cross Country™ motorcycles. Our records indicate that you have purchased a potentially affected vehicle.

***The reason for this recall:***

Victory has determined that some Model Year 2011 Victory Cross Country handlebar riser / clamp assemblies may be defective. The defective handlebar riser / clamp assemblies do not provide sufficient clamping force and may allow handlebars to rotate in the riser assembly. This could cause the vehicle operator to lose steering control, increasing the risk of a vehicle crash.

***What Victory and your dealer will do:***

Victory has issued *Safety Recall Bulletin V-11-01* to all Victory dealers, with instructions required to test and replace defective riser / clamp assemblies that provide insufficient clamping force. Repairs will be made by any authorized Victory motorcycle dealer at no cost to you. If handlebar riser / clamp replacement is required, the actual repair should take under 2 hours to perform; however, it may take longer due to service scheduling requirements.

***What you should do:***

Please call your authorized Victory motorcycle dealer to schedule an appointment to have the bulletin repair performed. Do not attempt repairs yourself. Repairs must be done only by an authorized Victory motorcycle dealer.

***Pre-Ride Inspection:***

Prior to riding your motorcycle to the dealership to complete the handlebar repair / inspection process, inspect the handlebars for obvious looseness. Sit astride the motorcycle in a normal riding position with your hands in the normal operating position. Attempt to lift the bars up. If the handlebars show movement, contact Polaris for additional information.

***If you have questions or if you need more information:***

While your Victory dealer is in the best position to answer your questions, if you have any questions that your dealer cannot address, if you are having difficulty obtaining the recall repair outlined in this letter, or if you need assistance finding a Victory Dealer, please visit the Polaris/Victory Motorcycle web site at [www.polarisindustries.com](http://www.polarisindustries.com) or contact our Victory Consumer Service Department by calling 1-888-704-5290.

This notice was mailed to you according to our most current registration information. If you no longer own your Victory motorcycle, please contact your local Victory dealer to have the ownership information changed. The Consumer Service Department cannot change ownership information without identification. Federal law requires that any vehicle lessor receiving this recall notice must forward a copy of this notice to the lessee within 10 days.

If you have had this repair performed before you received this letter, you may be eligible to receive reimbursement for the cost of obtaining a pre-notification remedy of the problem associated with this recall. For more information regarding obtaining reimbursement please contact the Victory Consumer Service Department using the contact information above.

If you believe that the Victory Motorcycle Division of Polaris Industries Inc. has failed to remedy this defect without charge or is unable to do so within a reasonable time, you may submit a complaint to the Administrator, National Highway Traffic Safety Administration, 1200 New Jersey Avenue SE., Washington, D.C. 20590; or call the toll-free Vehicle Safety Hotline at 1-888-327-4236 (TTY: 1-800-424-9153); or on the web go to <http://www.safercar.gov>.

Please accept our apologies for any inconvenience this may cause you. Your safety and continued satisfaction with your Victory motorcycle is our primary concern. Thank you for your prompt attention to this matter.

Sincerely,

A handwritten signature in black ink that reads "Bridget McLennan".

Bridget McLennan  
Warranty and Service Publications Manager