

TECHNICAL INSTRUCTIONS
FOR
SAFETY RECALL B0G
EPS PINION SHAFT NUTS REPLACEMENT
2001 – 2003 MODEL YEAR PRIUS

UPDATED AUGUST 31, 2011

TECHNICAL INSTRUCTION UPDATE NOTICE:

- Information has been updated for stationary steering torque measurement. (SECTION VIII, STEP B, #3)
- Information has been updated for securing the pinion shaft (SECTION IX, STEP 11)
- Information has been updated for lock nut tightening. (SECTION IX, STEP 14d)
- Information has been updated for torque sensor adjustment calibration (SECTION X, STEP 5)

Previous versions of these Technical Instructions should be discarded.

I. OPERATION FLOW CHART

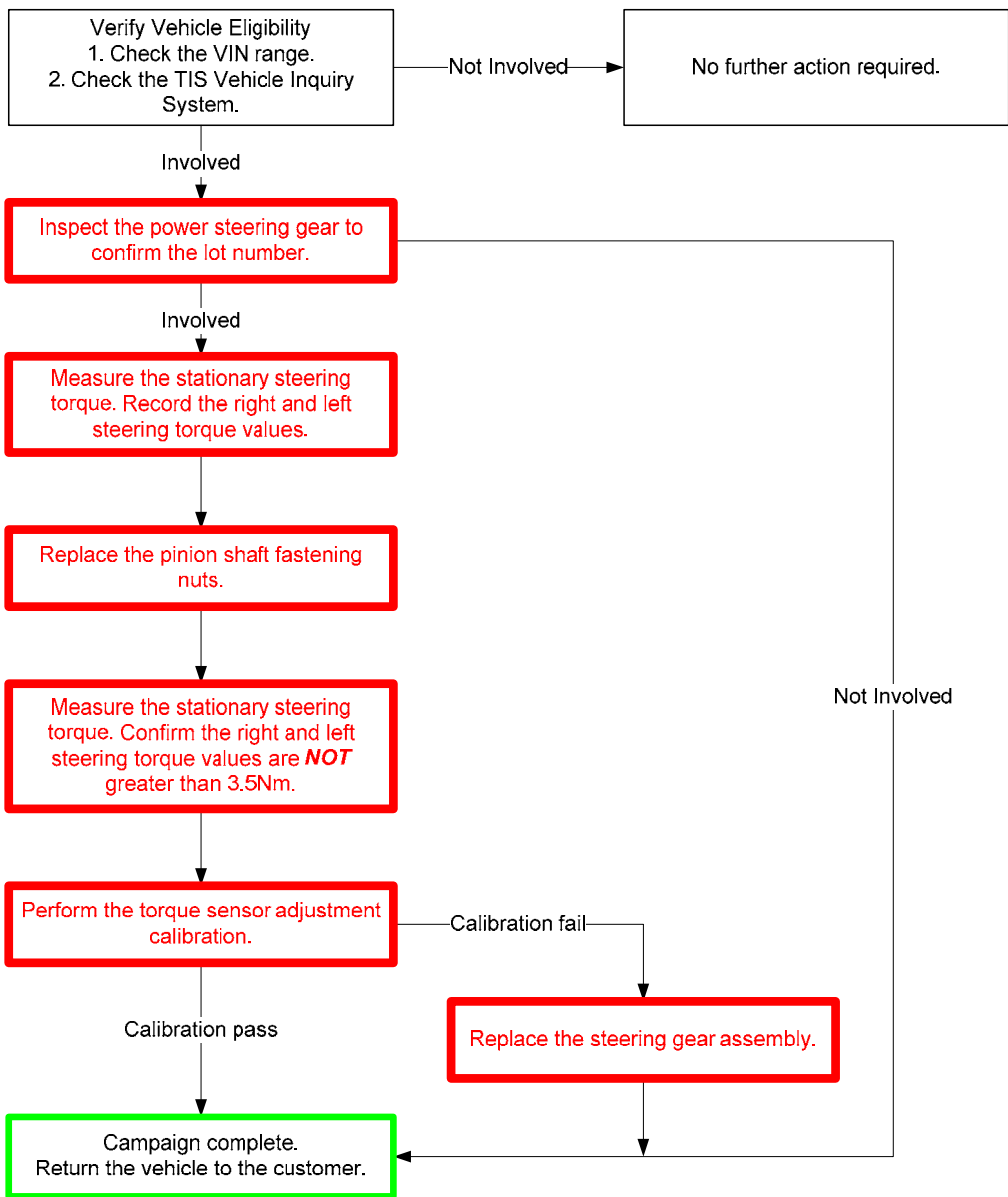

II. IDENTIFICATION OF COVERED VEHICLES

A. COVERED VIN RANGE

Model	WMI	Year	VIN Range	
			VDS	Range
Prius	JT2	2001	BK12U	0001034 - 0038684
			BK18U	0001005 - 0038005
		2002	BK12U	0038693 - 0070195
			BK18U	0038685 - 0070196
		2003	BK12U	0070201 - 0088781
			BK18U	0069295 - 0088779

NOTE:

- Check the TIS Vehicle Inquiry System to confirm the VIN is involved in this Safety Recall, and that the campaign has not already been completed prior to dealer shipment or by another dealer.
- TMS warranty will not reimburse dealers for repairs conducted on vehicles that are not covered or were completed by another dealer.

III. PREPARATION

A. PARTS

Part Number	Part Description	Quantity
04001-31147	EPS Gear Kit*	1
*The kit above includes the following parts:		
Part Number	Part Description	Quantity
90170-14033	Pinion Shaft Adjusting Nut	1
90170-14034	Pinion Shaft Lock Nut	1
95381-03020	Cotter pin	2
90119-12309	Bolt (50 mm)	2
90080-11623	Bolt (27 mm)	2
45292-47020	Main shaft lower dust seal	1
90119-14050	Bolt (66 mm)	2
90119-14092	Bolt (55 mm)	2
17451-21060	Exhaust Pipe Gasket	1









B. TOOLS, SUPPLIES & EQUIPMENT

- Standard hand tools
- Torque wrench
- Techstream
- Alignment machine
- Transmission jack (or similar)
- Toothbrush
- Brake cleaner
- Marking pen
- Toyota Genuine Adhesive 1344 or equivalent (Loctite 242, Threebond 1344)

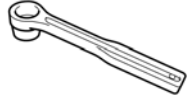
SST – These are essential special service tools that the dealership should have.

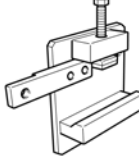
Part Number	Part Name	Quantity
00002-02955	Beam torque wrench	1
09960-20010	Ball joint puller set*	1
*The set above includes the following tools.		
Part Number	Part Name	Quantity
09961-02010	Ball joint puller assy	1
09961-02060	Spacer B (M12)	1

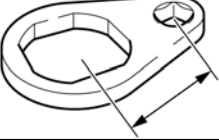
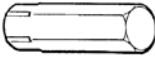
Campaign Tools – These tools will be provided to the dealership.

Part Name	Sample	Quantity	Part Name	Sample	Quantity
Crossmember hanger		2	Rack boot stopper		2
Adjusting nut holding wrench		1	Torque wrench attachment		1
Pinion shaft socket		1	Steering gear stand		1
Bearing protector		1	Rack guide lock nut wrench		1
Hexagon wrench 24mm		1	Pinion shaft cap		2

IV. BACKGROUND

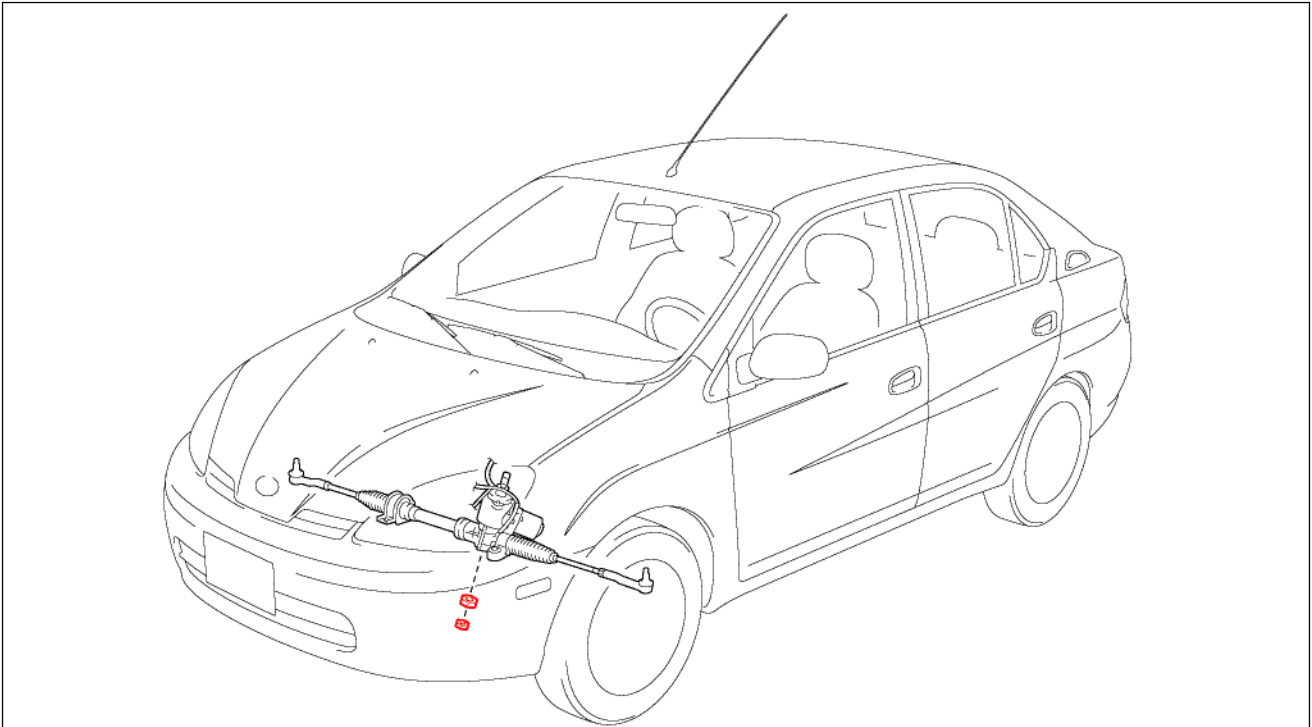

In the EPS system of the 2001 through 2003 Prius, due to the inadequate fixation of nuts that secure the pinion shaft in the steering gear box assembly, if the steering wheel is repeatedly and strongly turned to the full-lock position, there is a possibility that the nuts may become loose. If the vehicle is continuously operated in this condition, the pinion shaft may become unstable which may cause power generated by the electric motor to not be fully transmitted. This could result in significant increased steering effort when making a left turn increasing the risk of a crash.

V. WORK PROCEDURE TABLE OF CONTENTS

SAFETY PRECAUTIONS-----	SECTION VI
POWER STEERING GEAR INSPECTION-----	SECTION VII
POWER STEERING GEAR REMOVAL-----	SECTION VIII
PINION SHAFT DOUBLE NUT REPLACEMENT-----	SECTION IX
POWER STEERING GEAR INSTALLATION-----	SECTION X

VI. SAFETY PRECAUTIONS

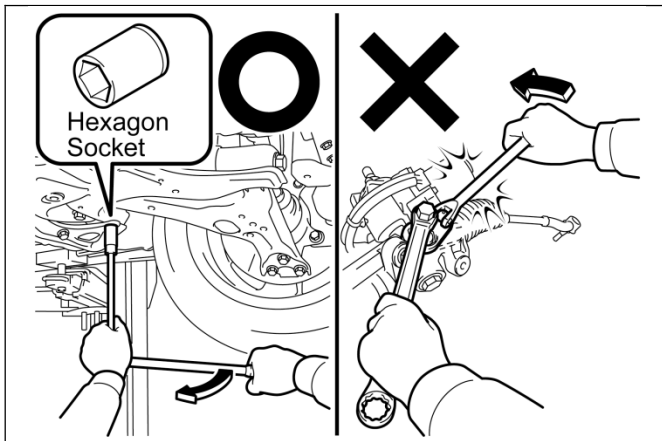

1. LOOSENING OF NUTS AND BOLTS

- Due to vehicle age, some nuts and bolts may be extremely tight or stuck, be sure to use safe procedures at all times when removing stuck nuts and bolts.

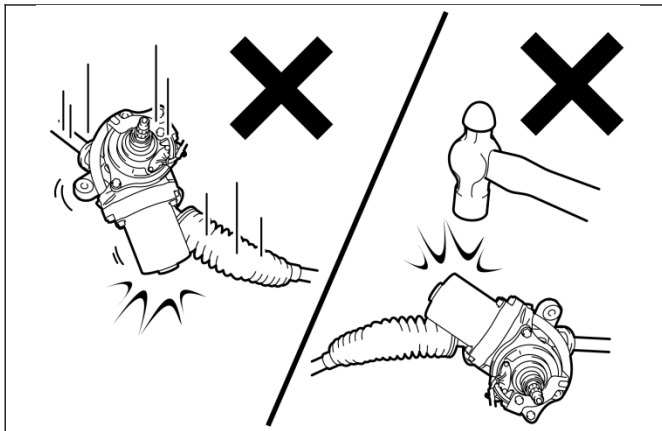

2. HANDLING THE STEERING GEAR

- The steering gear assembly is a precision part, be careful not to drop or subject the gear to impacts.

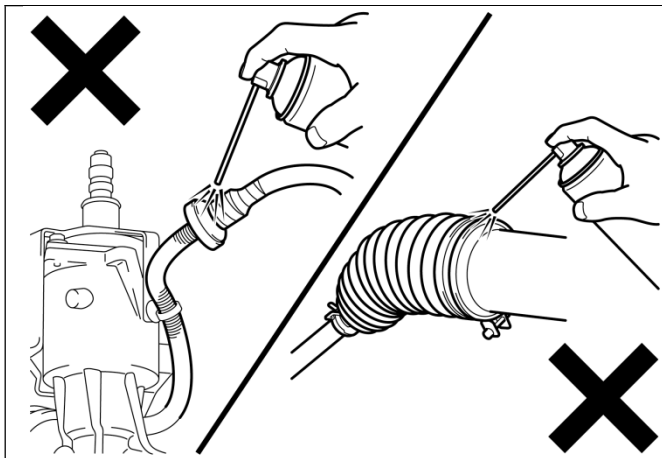

3. USING CHEMICALS ON THE STEERING GEAR

- DO NOT** use oil or grease on rubber or plastic parts on the steering gear assembly.
- When using brake cleaner, be careful to not displace excessive amounts of steering gear grease.

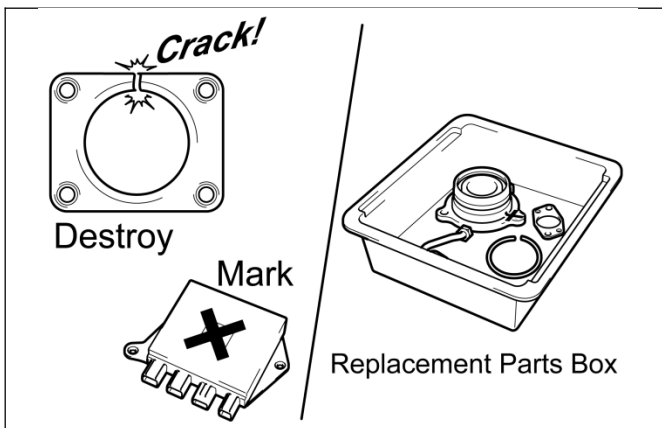

4. HANDLING OF REPLACEMENT PARTS

- To prevent the reuse of any non-reusable parts, mark the parts and destroy them as appropriate.

VII. POWER STEERING GEAR INSPECTION

A. LOCATE AND INSPECT THE LOT NUMBER STICKER ON THE POWER STEERING GEAR

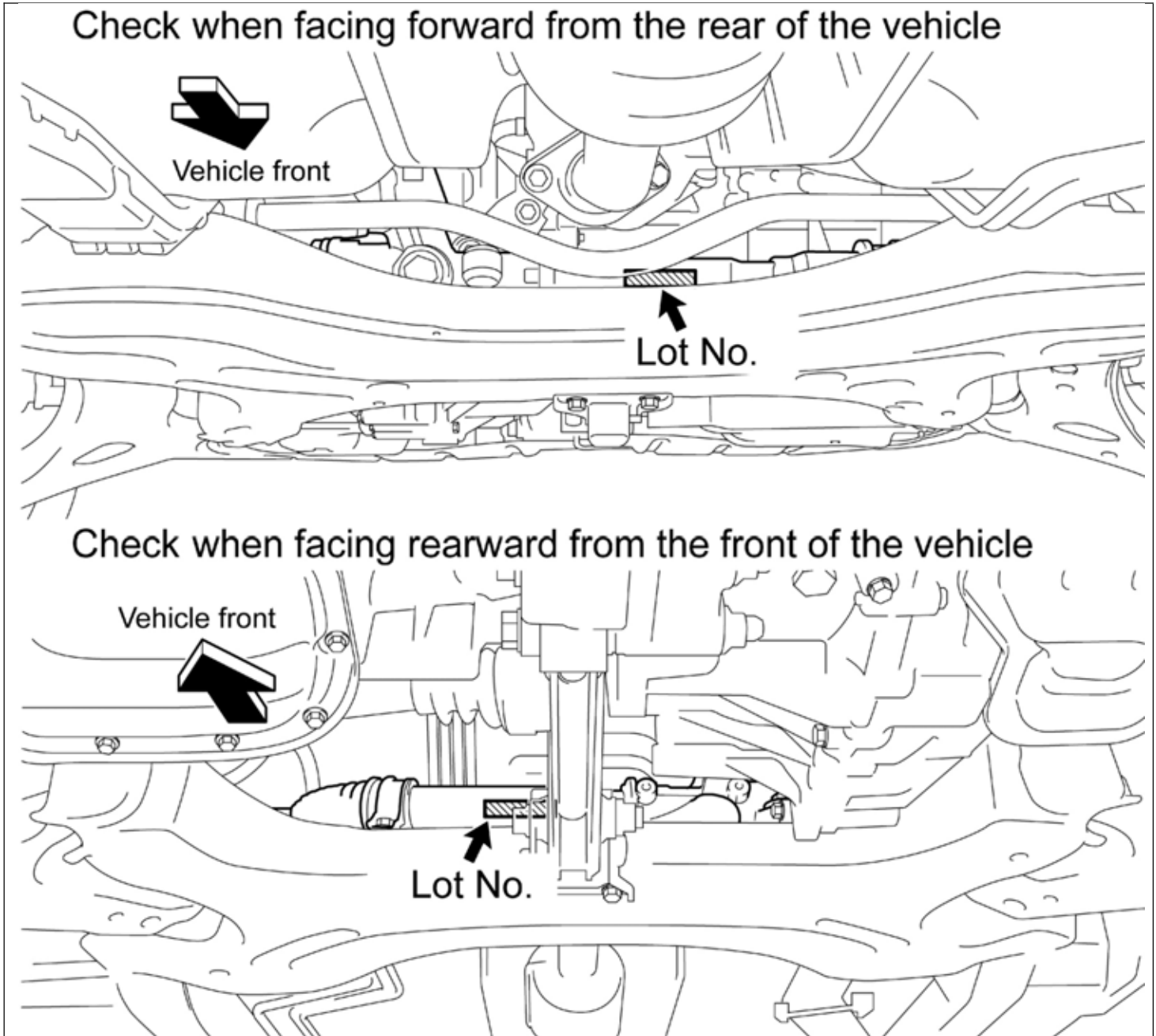

INSPECTION RESULT	ACTION REQUIRED
Below 138897 OR lot number cannot be determined	Proceed to SECTION VIII. POWER STEERING GEAR REMOVAL.
138897 or above	Record the lot number on the repair order. No further action is required. Campaign complete.

VIII. POWER STEERING GEAR REMOVAL

A. COMPONENTS

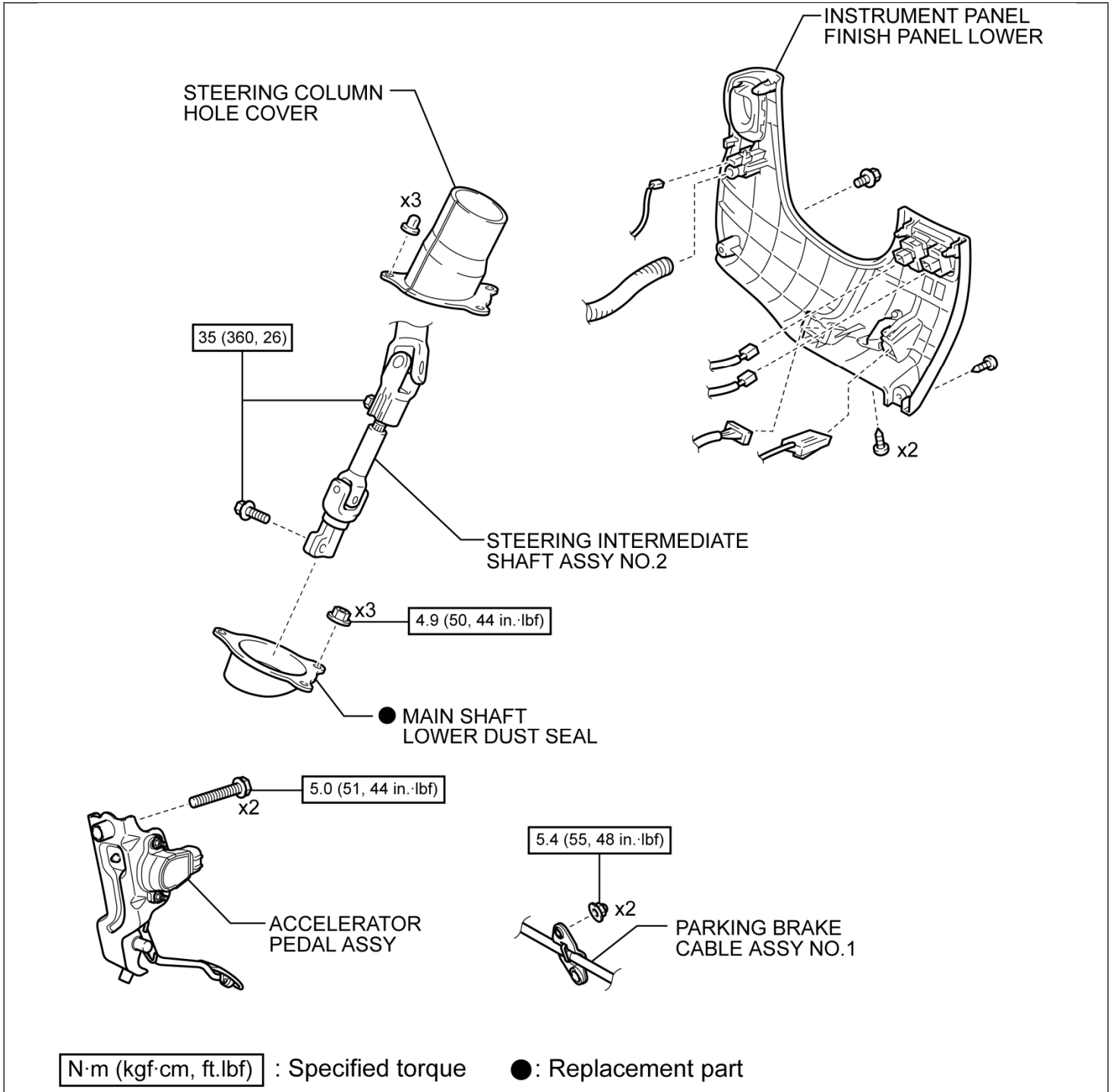

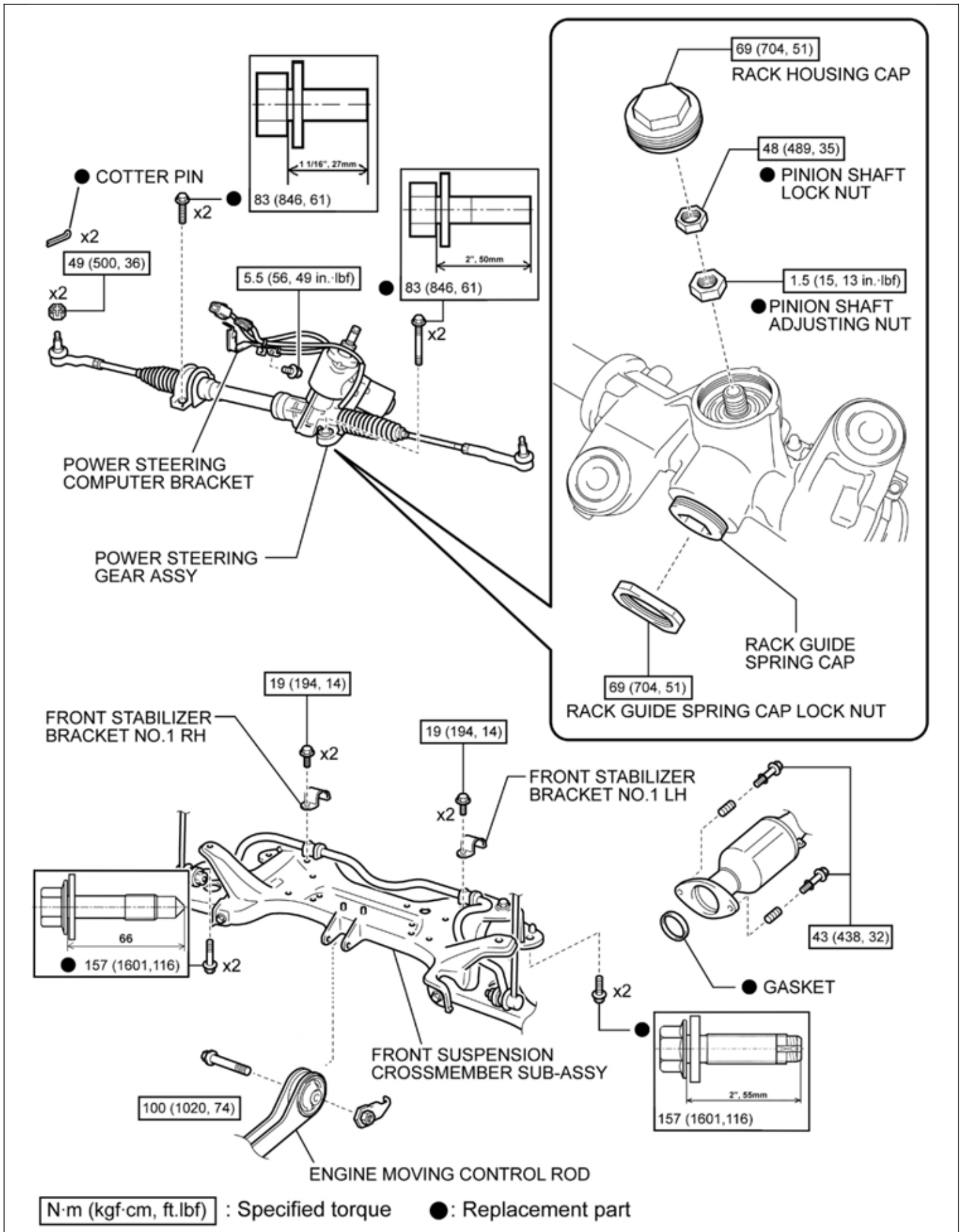

B. MEASURE THE STATIONARY STEERING TORQUE

1. ADJUST THE TIRE PRESSURE TO THE SPECIFIED VALUE

Cold tire inflation pressure:

Front – 35PSI (240kPa, 2.4kg/cm²)

Rear – 33PSI (230 kPa, 2.3kg/cm²)

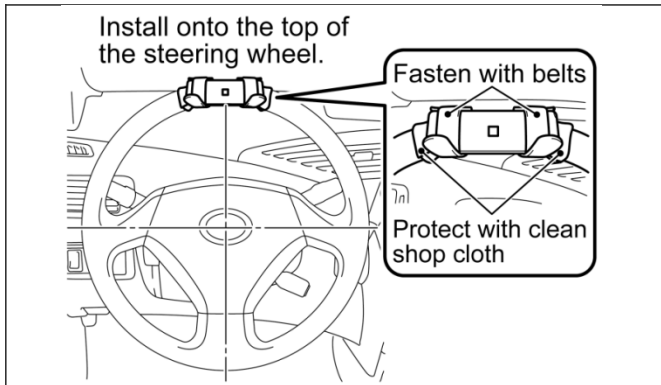

2. INSTALL THE TORQUE WRENCH ATTACHMENT TO THE STEERING WHEEL AS SHOWN

NOTE:

- Be sure to protect the steering wheel with a shop cloth when installing the torque wrench attachment.
- If the torque wrench is contacting the windshield or A-pillar when taking this measurement, the attachment position can be moved to another spot on the circumference of the steering wheel.

**THE FOLLOWING INSPECTION STEP IS VITAL.
CONFIRM THIS STEP IS FOLLOWED CLOSELY.**

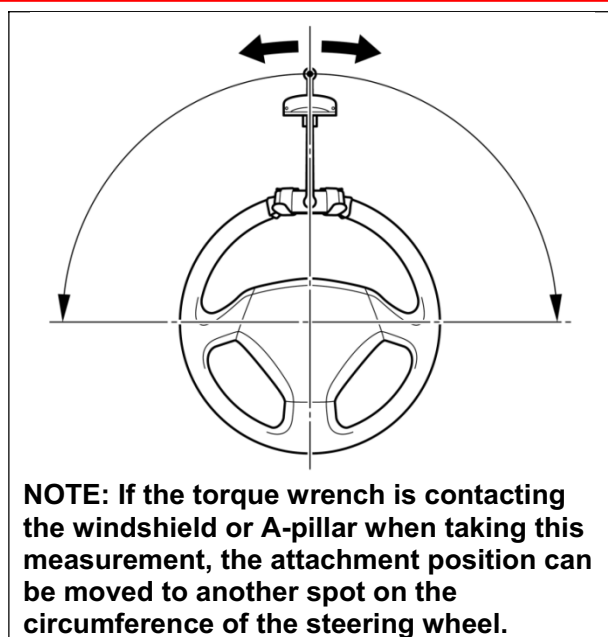

3. MEASURE THE STATIONARY STEERING TORQUE

- Position the vehicle on a dry, flat paved surface.
- Connect the SST torque wrench (00002-02955).
- Turn vehicle to READY ON.
- Start with the wheels straight ahead. Turn the steering wheel ¼ turn to the left of center, then ¼ turn to the right of center using the torque wrench.
- Record the right and left steering torque values.



- This information can be used when explaining the change in the steering effort that may result from this work.
- This measurement will need to be taken after the work is completed, with the vehicle in the same location.
- **DO NOT** perform this inspection on alignment slip plates or on an epoxy covered shop floor.

C. DISCONNECT THE STEERING INTERMEDIATE SHAFT ASSEMBLY NO. 2

1. CHECK FOR DIAGNOSTIC TROUBLE CODES

- If any DTCs are output, record the data and perform the repairs as necessary.

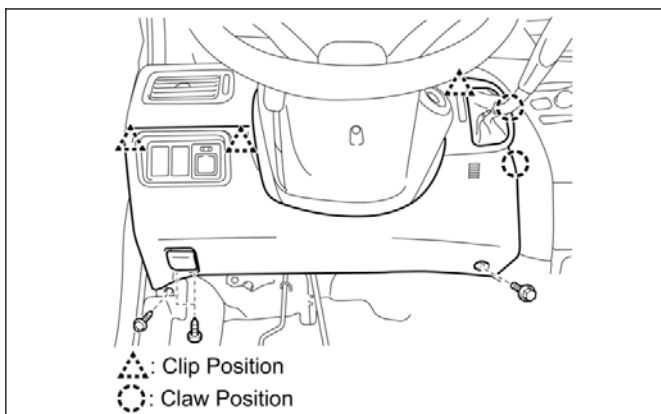

2. REMOVE THE INSTRUMENT PANEL FINISH PANEL LOWER

- Move the shift lever to the B position to ease in panel removal.
- Open the fastener on the shift lever cover.
- Remove the 2 screws and disengage the hood lever.
- Remove the 1 bolt and 1 screw and disengage the 3 clips and 2 claws.
- Disconnect the connectors and hoses and remove the panel.
- Confirm IG off and remove the key from the ignition.

3. ATTACH SIGN PROHIBITING IG ON

- Make a copy and be sure to place in vehicle during work.

IG ON PROHIBITED
(To prevent erroneous
diagnosis code output while
steering gear is removed.)

In charge: _____



4. REMOVE THE STEERING COLUMN HOLE COVER

- a) Fold back the floor carpet and remove the 3 clips, then remove the hole cover.

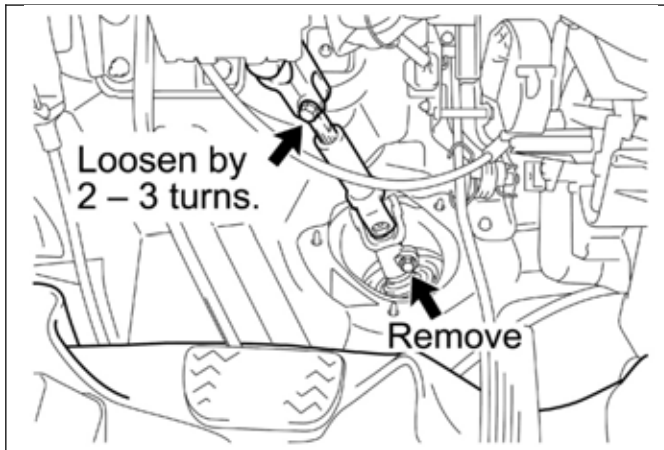

5. UNFASTEN THE STEERING INTERMEDIATE SHAFT ASSEMBLY NO. 2

- a) Loosen the top bolt by 2 to 3 turns.
- b) Remove the bottom bolt.

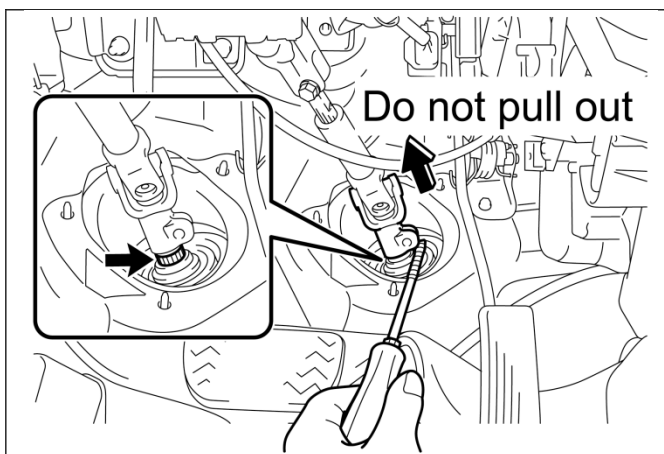

- c) Use a flathead screwdriver wrapped in tape to lift the intermediate shaft so that the pinion shaft is visible.

NOTE: DO NOT pull the shaft completely off of the pinion before making match marks.

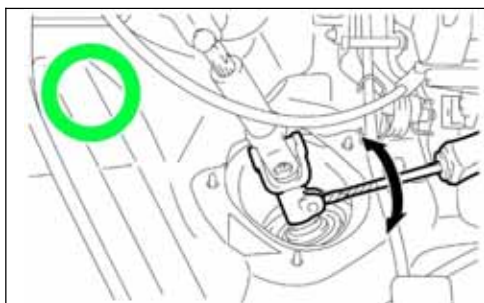

If the shaft is stuck, insert a flathead screwdriver wrapped in tape into the slit and pry.

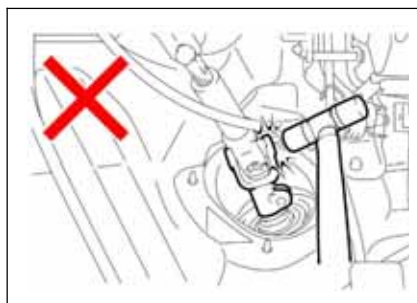

NEVER strike the shaft. Doing so may cause malfunctions in the steering assist control system.

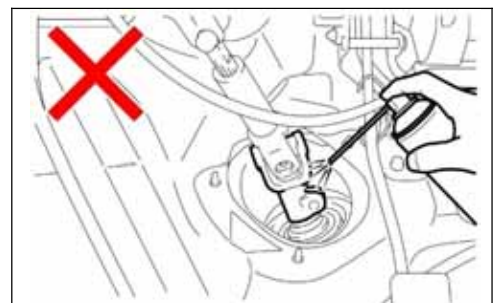

NEVER apply lubricant to the shaft. Doing so will change the friction coefficient, and may cause the bolt to become loose or to break when tightened.

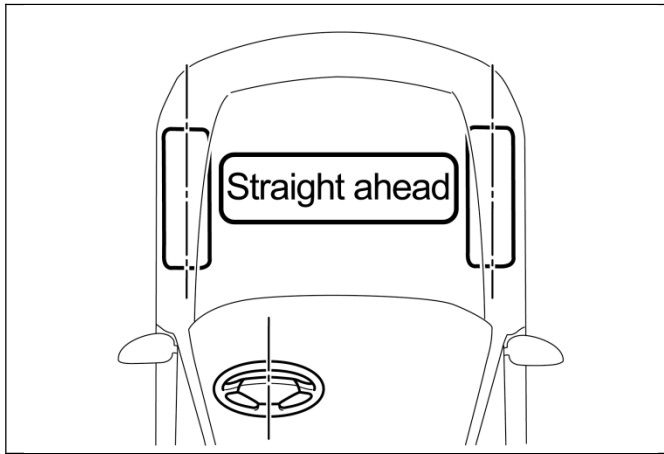

6. POSITION THE STEERING WHEEL STRAIGHT AHEAD

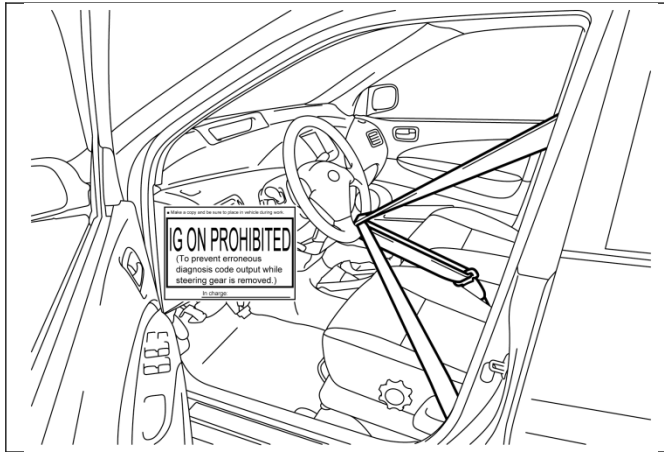

7. SECURE THE STEERING WHEEL IN THE STRAIGHT AHEAD POSITION

- a) Pass the seatbelt through the steering wheel and fasten the seatbelt.
 - b) Move the seat rearward to tense the seatbelt.
- NOTE:** If the steering wheel is not secured, the spiral cable may be damaged.

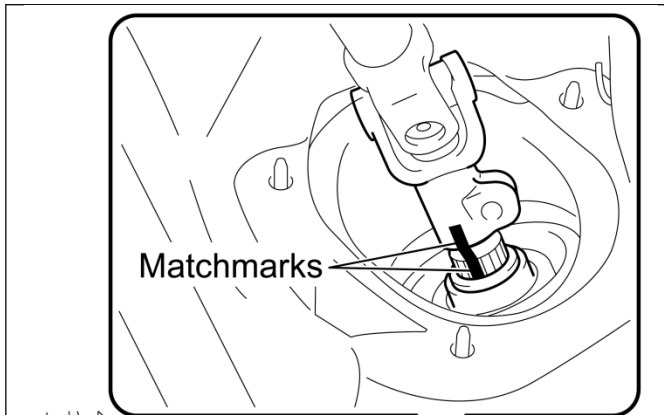

8. APPLY MATCH MARKS TO THE INTERMEDIATE SHAFT AND STEERING GEAR PINION SHAFT

- a) After applying the match marks, disconnect the intermediate shaft from the pinion shaft.

9. INSTALL THE PINION SHAFT PROTECTIVE CAP

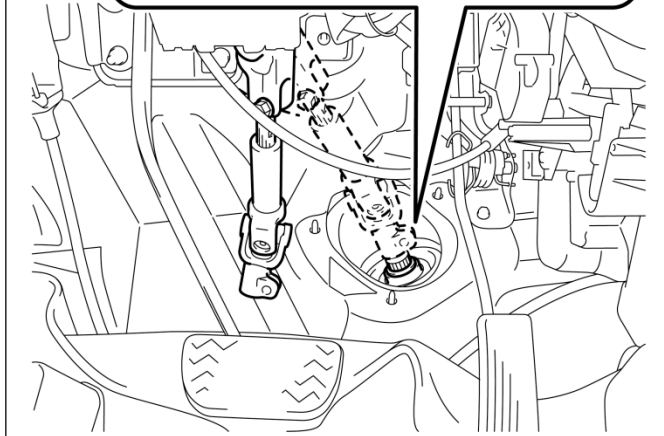

D. REMOVE THE POWER STEERING GEAR ASSEMBLY

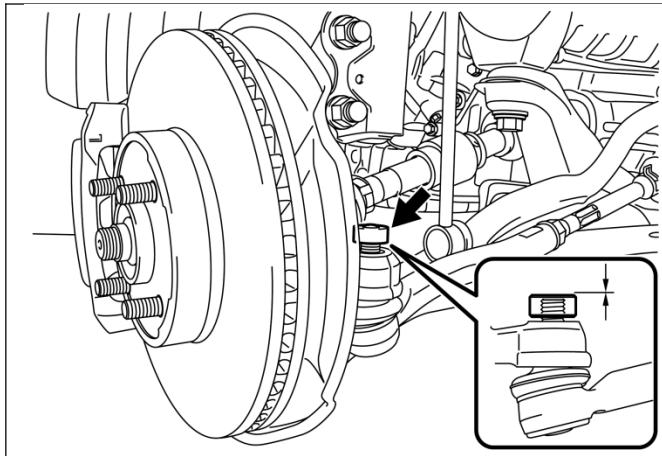

1. REMOVE BOTH FRONT TIRES

2. DISCONNECT BOTH FRONT TIE ROD ENDS

- Remove the cotter pin (**NEW cotter pins provided in kit**) and castle nut.
- Install SST spacer B (M12) so that it is even with the end of the tie-rod end bolt.

SST 09960-20010 (09961-02060)

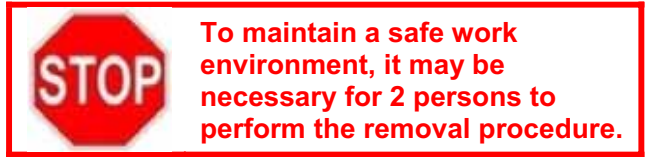

- Install the SST so that A and B are parallel.
- Disconnect the tie rod end.

NOTE: Connect the SST to the coil spring to prevent it from falling.

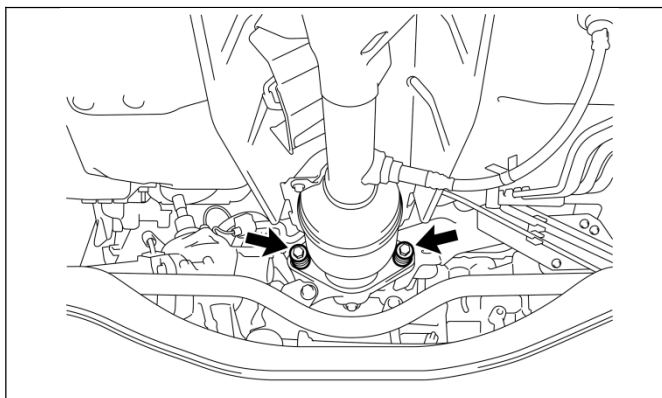
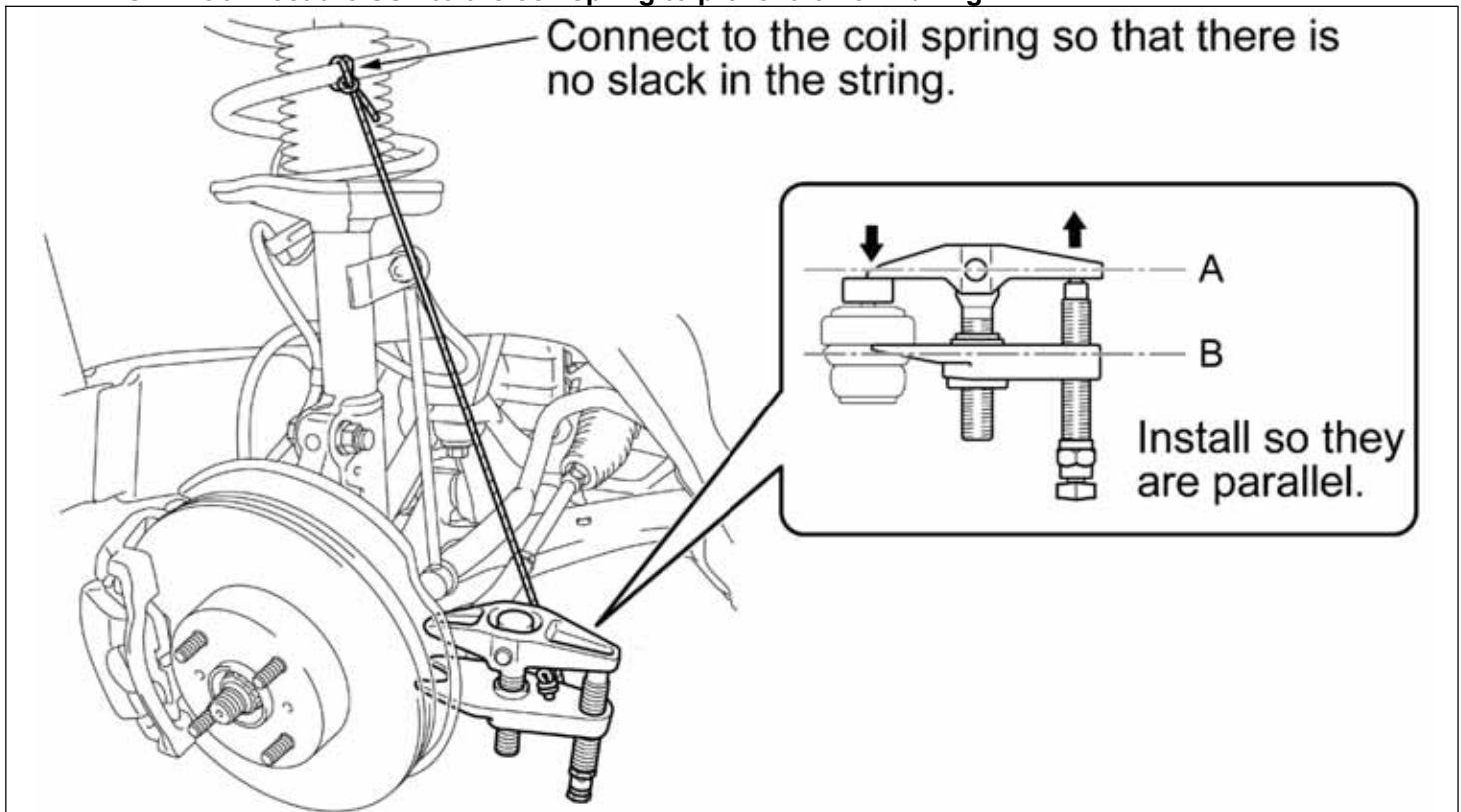

3. DISCONNECT THE FRONT EXHAUST PIPE ASSEMBLY

- Remove the 2 bolt and 2 compression springs.

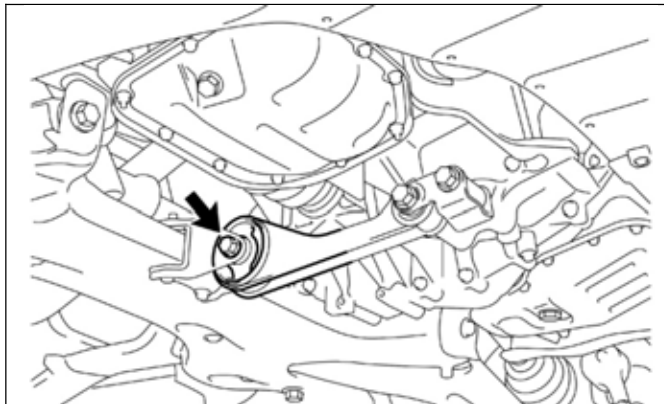

4. DISCONNECT THE REAR END OF THE ENGINE MOVING CONTROL ROD

- a) Remove the bolt and disconnect the control rod.



5. LOWER THE FRONT SUSPENSION CROSSMEMBER

- a) Use a transmission jack to support the crossmember.
- b) Remove the 4 crossmember bolts (**NEW parts provided in kit**).

NOTE: Wear protective goggles when removing the bolts, water that may have accumulated in the body will spill out when removing the bolts.

- c) Slowly lower the crossmember until there is a 4 in. (10 cm) gap between the rear of the crossmember and the body.
- d) Install the crossmember hangers.



- Failure to install the crossmember hangers could damage the lower ball joints and steering gear wire harness, and will cause a safety concern.
- Be sure to fully install the crossmember hangers.

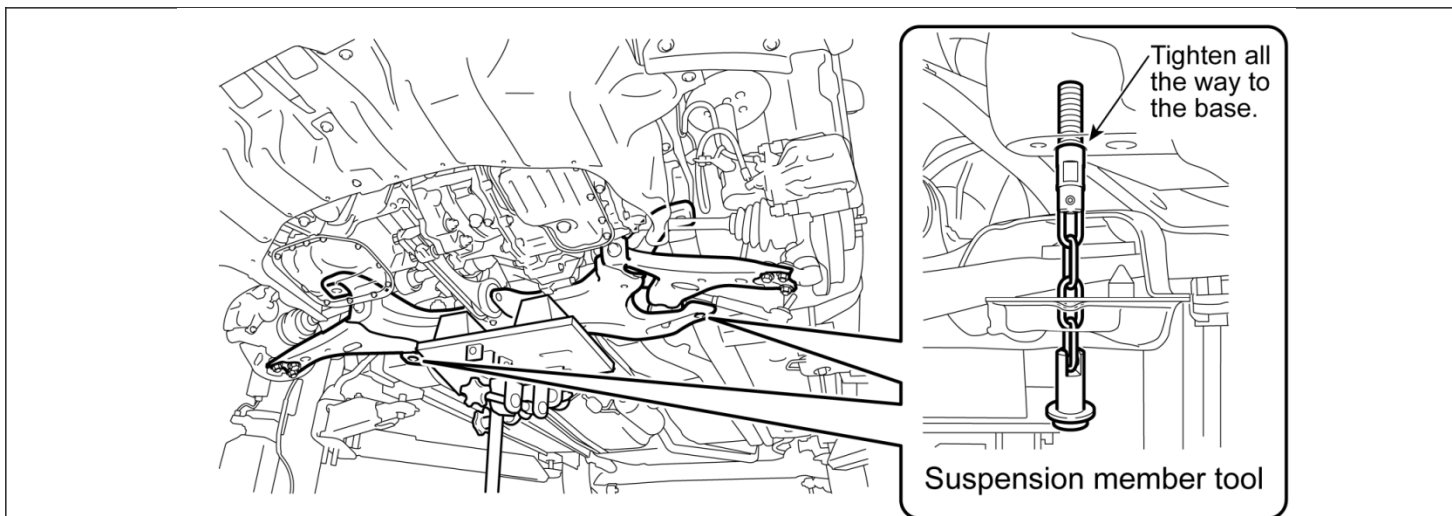

- e) Disconnect the 2 steering gear wire harness connectors.
- f) Remove the bolt and disengage the wire harness bracket.

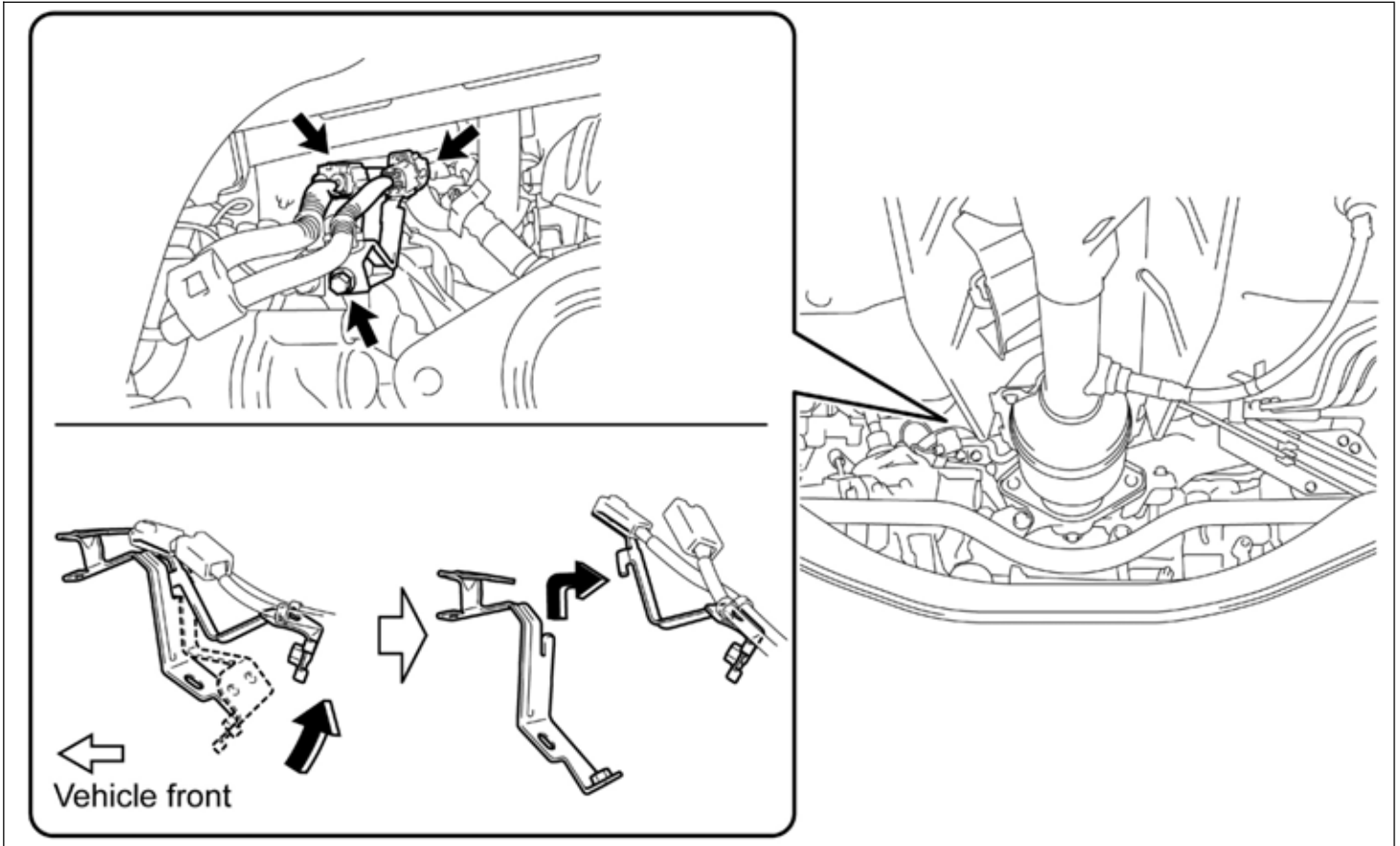

- g) Slowly lower the jack until the crossmember contacts the suspension member tools.

NOTE: Be careful that the pinion shaft does not contact the HV wire harness.

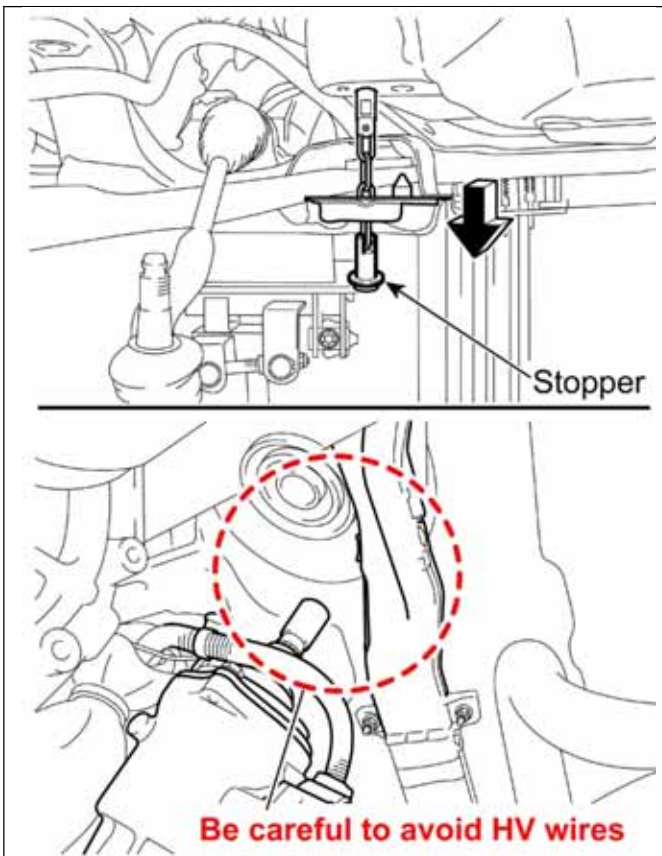

Continue to support with the jack.

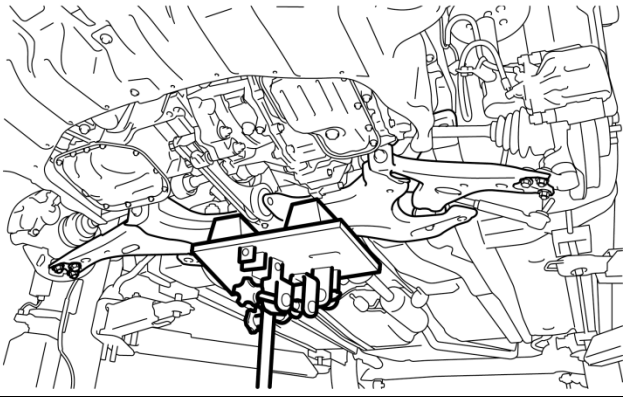

- h) Continue to support the crossmember with the jack.
NOTE: DO NOT remove the jack.

6. REPLACE THE EXHAUST PIPE GASKET

- a) Remove the old gasket.
- b) Install the new gasket, if necessary, use a wooden block and hammer to fully install the gasket.

NOTE: DO NOT put excessive force on the exhaust pipe when replacing the gasket.

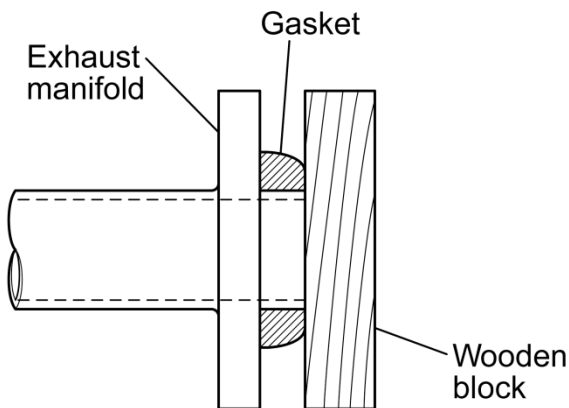

7. PROTECT THE STEERING GEAR CONNECTORS

- a) Cover the connectors with a plastic bag to prevent them from being caught, damaged or fouled with cleaner during removal and disassembly.

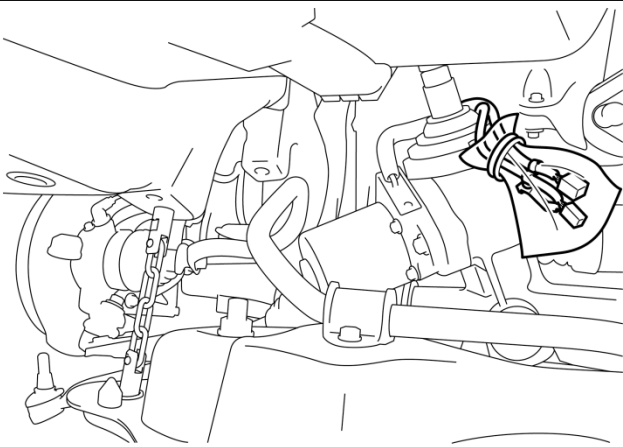

8. DISCONNECT THE STABILIZER BAR

- a) Remove the 4 bolts.
- b) Remove the 2 brackets and disconnect the stabilizer bar from the crossmember.

NOTE: There is NO NEED to remove the brackets or bushings from the stabilizer bar if stuck.

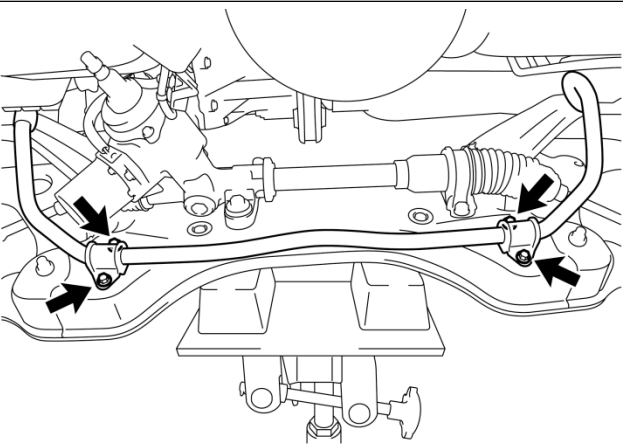

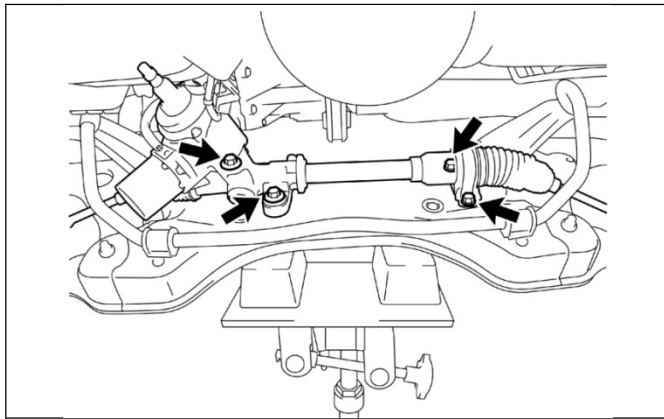

9. REMOVE THE POWER STEERING GEAR ASSEMBLY

- a) Remove the 4 bolts (**NEW** parts provided in kit).

NOTE:

- These bolts will be replaced.
- There is **NO NEED** to remove the bracket or bushing from the steering gear if stuck.

- b) Move the steering gear assembly towards the front of the vehicle and turn the assembly so the pinion shaft faces the rear of the vehicle.

NOTE: Be careful that the pinion shaft does not contact the HV wire harness.

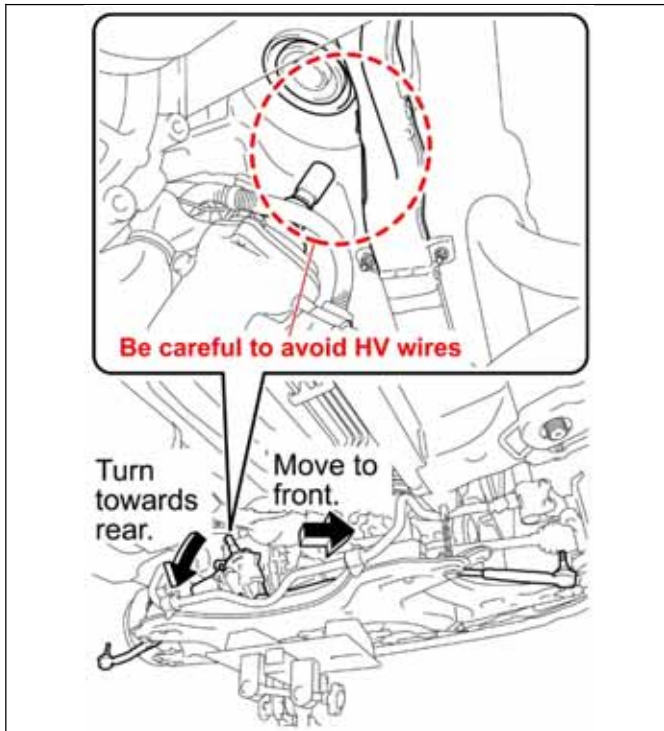

- c) Move the gear to the right side of the vehicle.
 d) Remove the gear through the rear of the vehicle beginning with the left tie rod end.

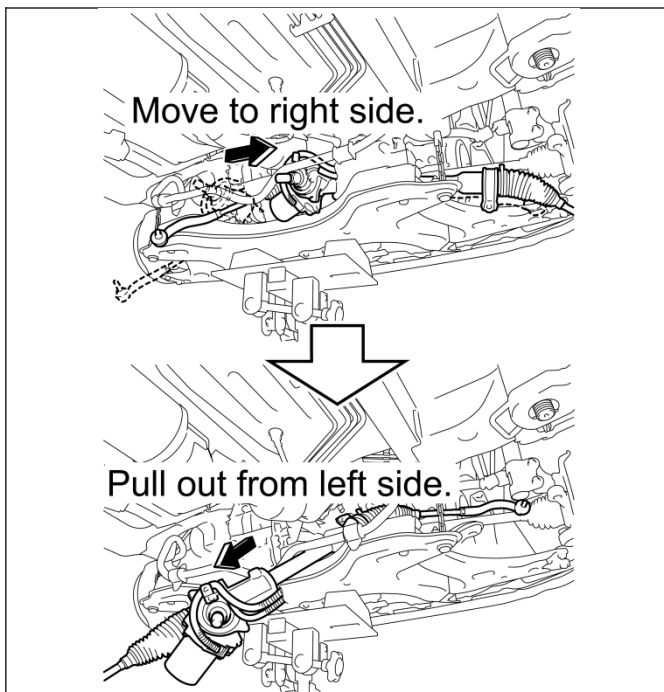

E. REPLACE THE MAIN SHAFT LOWER DUST SEAL

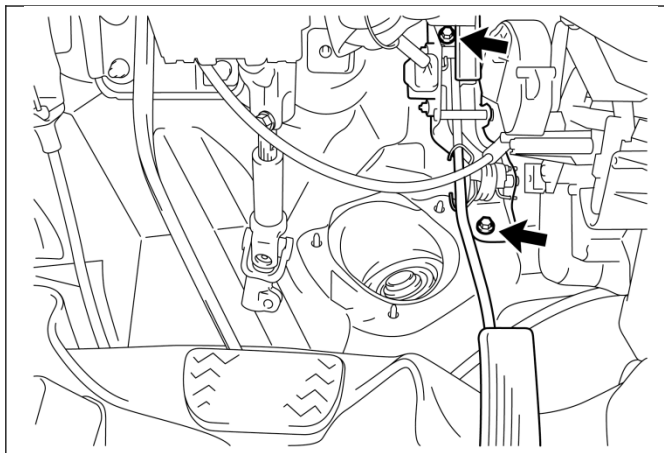

1. REMOVE THE ACCELERATOR PEDAL ASSEMBLY

- a) Disconnect the connector and remove the 2 bolts and accelerator pedal.

NOTE: Use hand tools only.

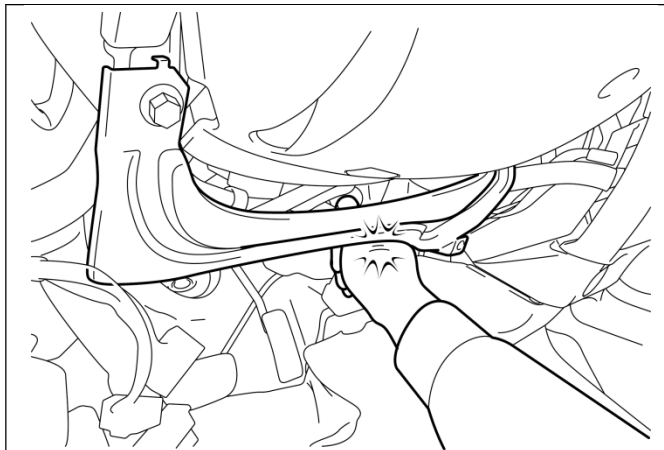

NOTE: Be careful not to be injured by the edges of the instrument panel bracket.

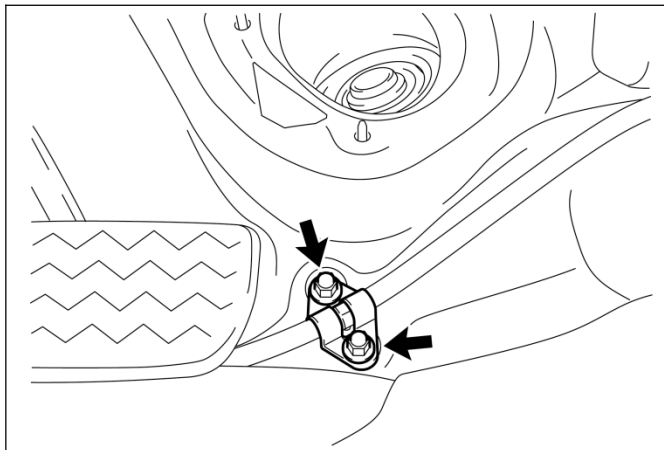

2. REMOVE THE PARKING BRAKE WIRE BRACKET

- a) Remove the 2 nuts and the parking brake wire bracket.

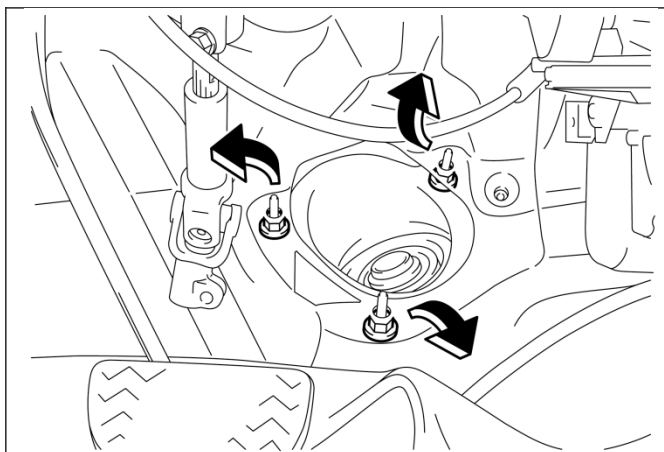

3. REPLACE THE MAIN SHAFT LOWER DUST SEAL

- a) Fold back the floor sheet and remove the 3 nuts and the dust seal.

NOTE: To avoid tearing the floor sheet *DO NOT* pull too hard.

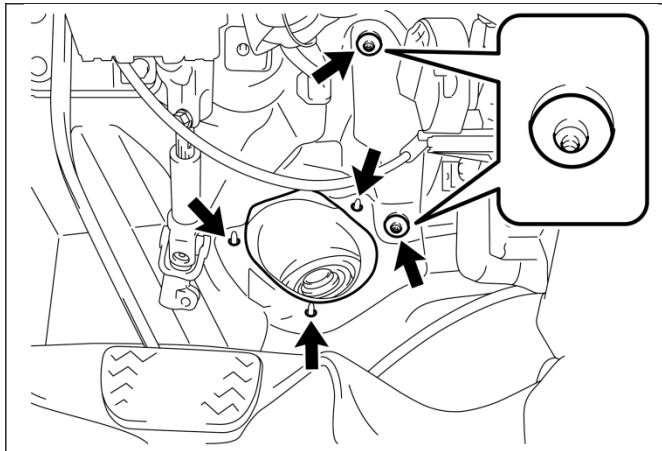
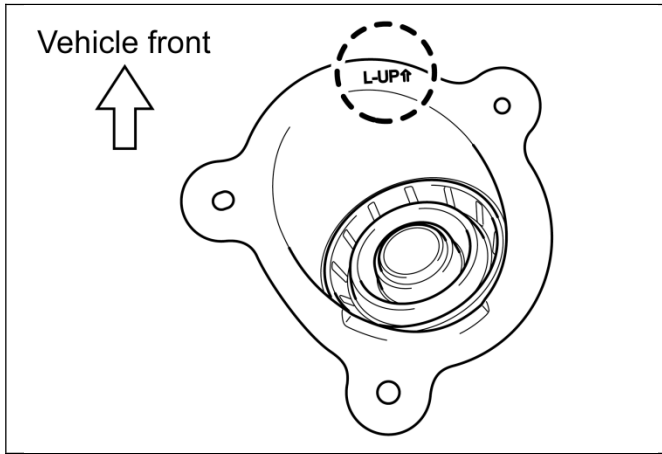

- b) Check the orientation before installing the new dust seal.

L-UP: Towards the front of the vehicle

- c) Install the new dust seal.
- d) Confirm the floor sheet and silencer are not trapped under the new dust seal.

NOTE: Water and noise entry may occur if the dust seal is not installed correctly.

- e) Install the 3 nuts.

Torque: 43.4 in.lbf (4.9 Nm, 50 kgf cm)

NOTE: To avoid tearing the floor sheet DO NOT pull too hard.

- f) Return the floor sheet to its original position.

4. INSTALL THE PARKING BRAKE WIRE BRACKET

- a) Install the 2 nuts.

Torque: 48 in.lbf (5.4 Nm, 55 kgf cm)

5. INSTALL THE ACCELERATOR PEDAL ASSEMBLY

- a) Install the 2 bolts.

Torque: 44 in.lbf (5 Nm, 51 kgf cm)

NOTE: Confirm the floor sheet is not trapped under the pedal.

IX. PINION SHAFT DOUBLE NUT REPLACEMENT

FOLLOW ALL OF THE STEPS BELOW. FAILURE TO FOLLOW THESE STEPS WILL RESULT IN THE STEERING GEAR BEING REPAIRED INCORRECTLY.



In order to prevent foreign substances from entering the steering gear assembly, do not work with dirty hands and do not use gloves or cloths when working on the steering gear assembly.

1. SECURE THE POWER STEERING GEAR ASSEMBLY IN THE STAND AND VICE

- Confirm the stand is set up correctly before installing on the gear.
- Wrap a shop cloth around the gear housing before securing the gear in the stand.

NOTE: Be sure to tighten the vice securely while working on the steering gear assembly.

INCORRECT steering gear stand set-up



CORRECT steering gear stand set-up

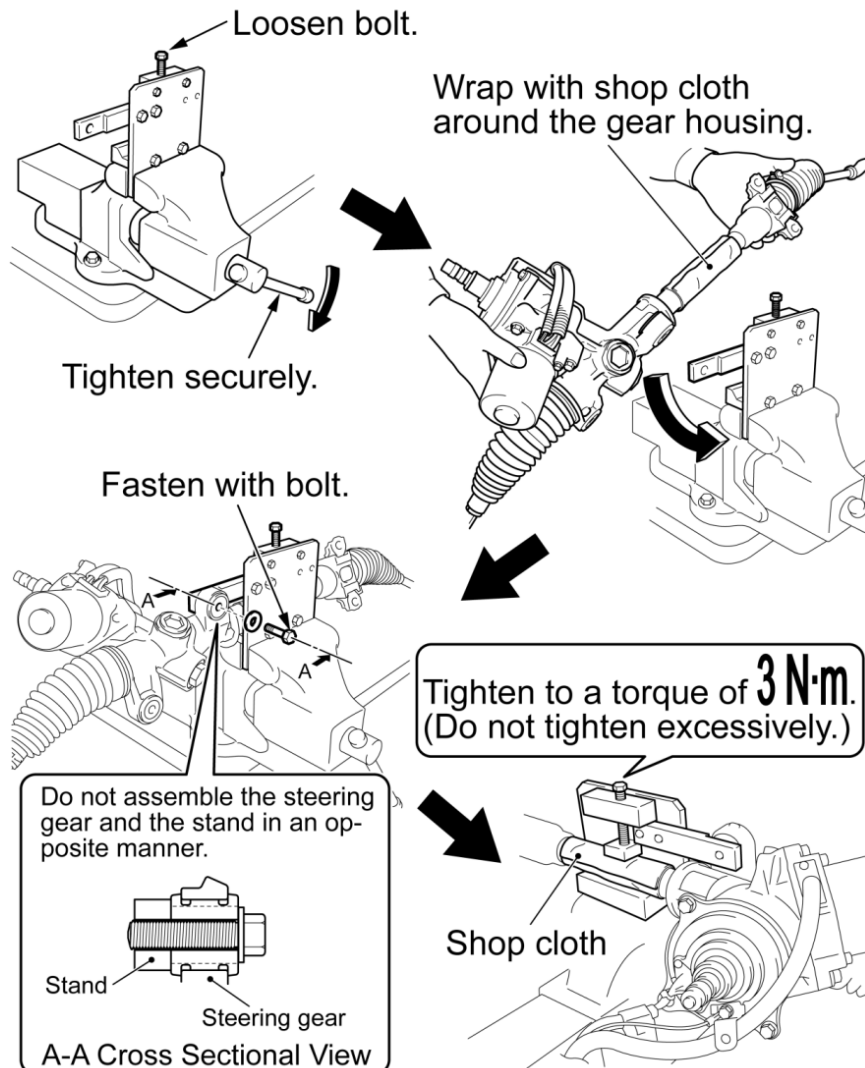

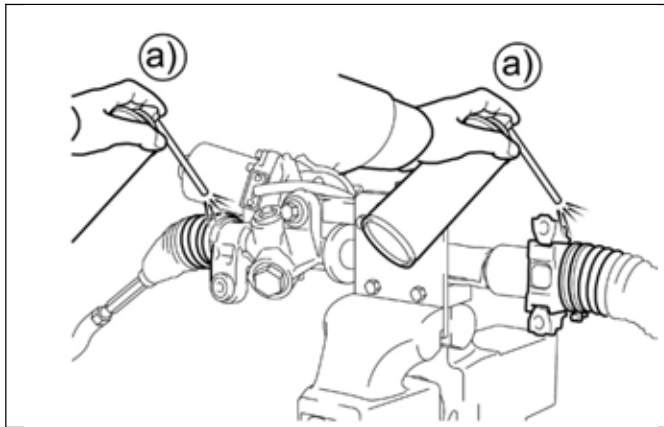

2. CLEAN THE GEAR ASSEMBLY

- a) Clean around the dust boots using paper towel, brake cleaner, and an air gun.

NOTE: In order to prevent foreign substances from entering the gear assembly when disassembled, these steps MUST be performed.

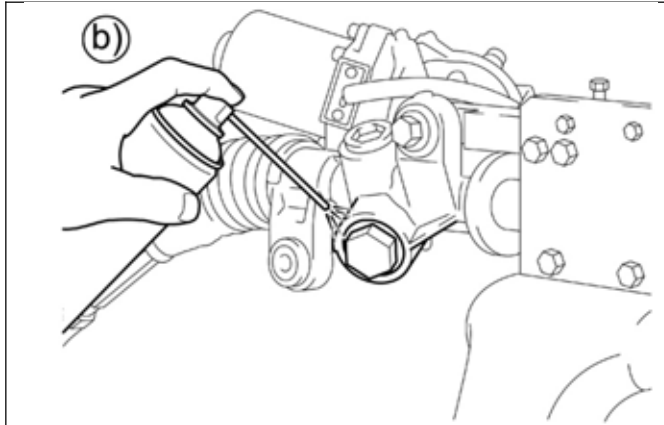

- b) Clean around the rack housing cap using paper towel, brake cleaner, and an air gun.

3. MARK THE RACK GUIDE SPRING CAP

- a) Using a center punch, mark the center of the flat part of the gear housing.
- b) Make a mark on the spring cap that aligns with the mark made on the gear housing.

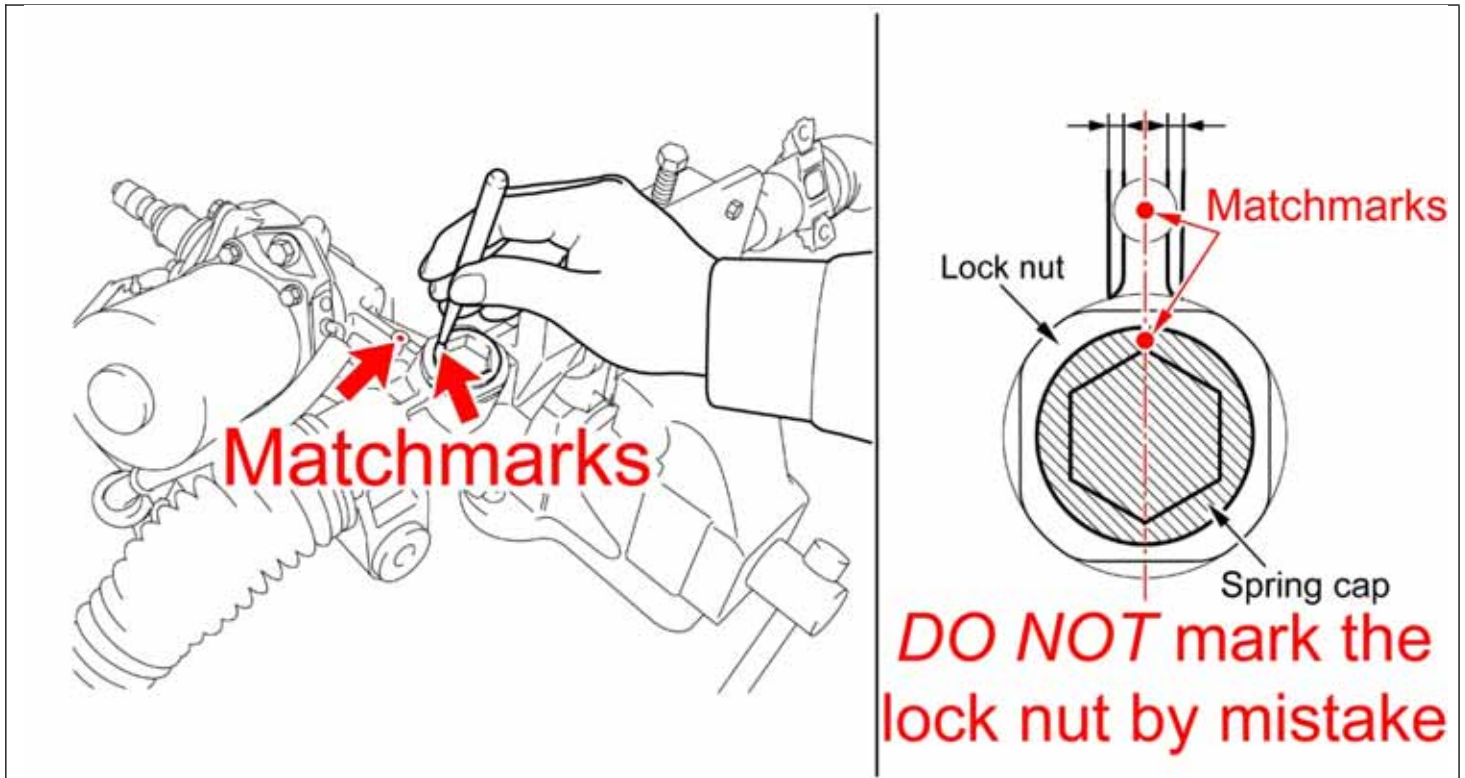

NOTE:

- During the work procedure the spring cap will be adjusted, these marks are essential to returning the cap to its original position.
- **DO NOT** place the match mark on the lock nut.
- Confirm that you are looking straight down at the steering gear when placing the match marks. If the marks are made when not viewing from directly above, the match marks will be deviated.

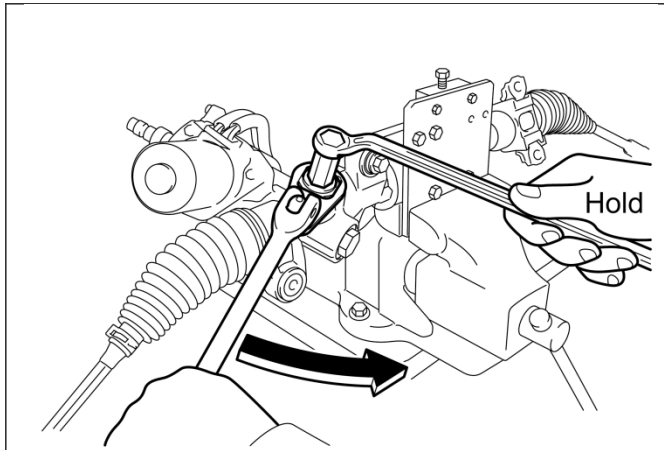
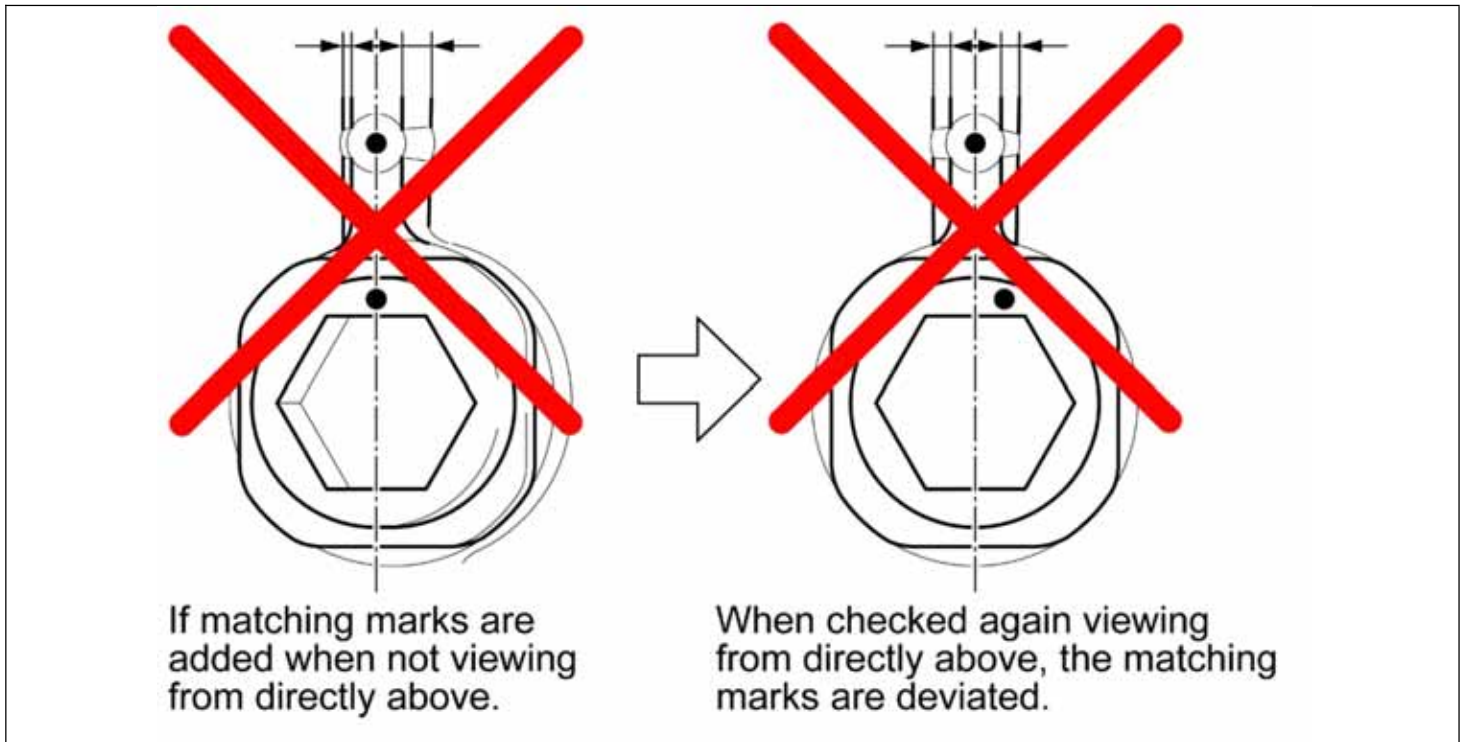

4. REMOVE THE RACK GUIDE SPRING CAP LOCK NUT

- a) Use the hexagon wrench 24mm to hold the spring cap while using the rack guide lock nut wrench to remove the lock nut.

NOTE: The lock nut is thin and the wrench may slip off easily.

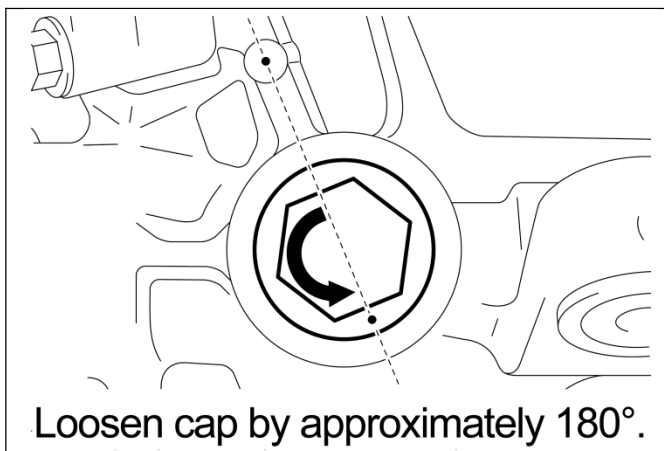

5. LOOSEN THE RACK GUIDE SPRING CAP

- a) Use the hexagon wrench 24mm to loosen the spring cap approximately 180 degrees.

NOTE To avoid contamination, **DO NOT** remove the cap or loosen greater than 180 degrees.

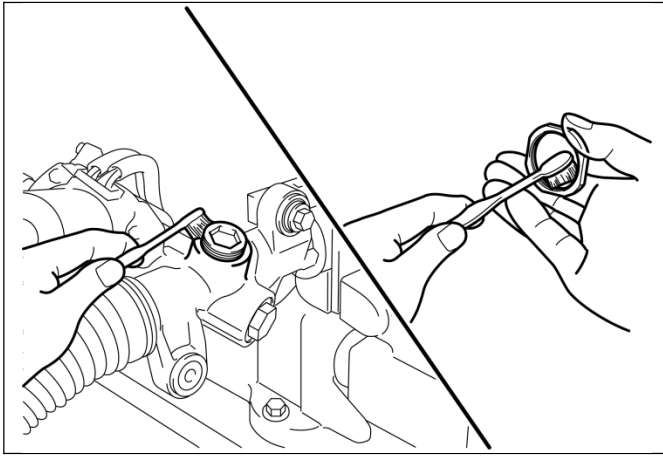

- b) Clean the rack guide spring cap and lock nut using a toothbrush and an air gun.



- **DO NOT** move the cap during cleaning.
- To prevent scratching of the gear housing, **DO NOT** use a wire brush.

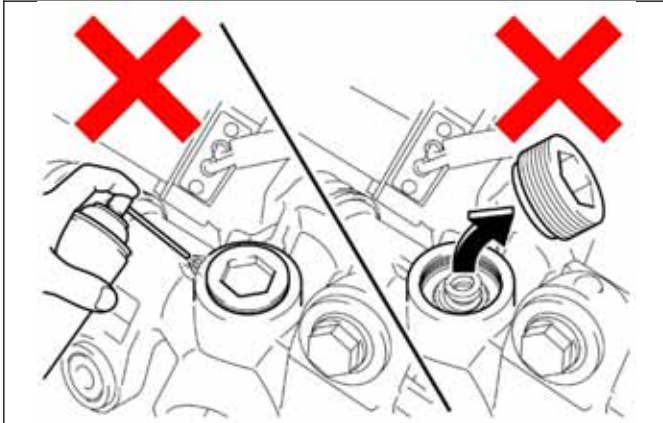

- **DO NOT** use brake cleaner. There is a risk of it entering the steering gear.
- **DO NOT** remove the cap.

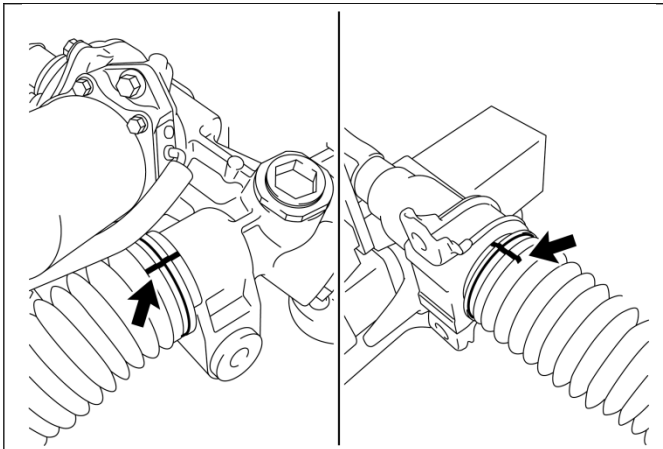

6. DISCONNECT THE STEERING RACK BOOTS

- Add match marks to the rack boots, clamps, and gear housing.
- Loosen the clamp screws. **DO NOT** remove the screws.
- Disconnect the boots from the gear housing.

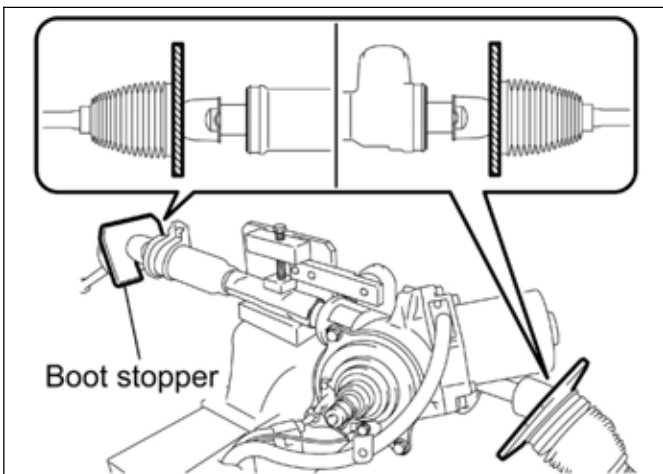

- Install the rack boot stoppers.

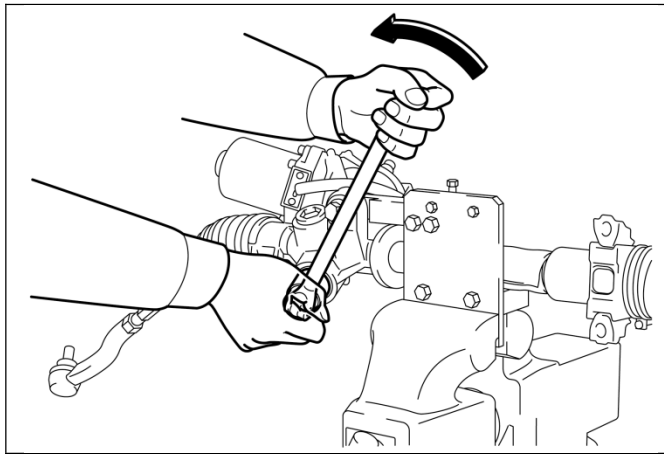

7. REMOVE THE RACK HOUSING CAP

NOTE: The cap opening is pointed slightly downwards to prevent brake cleaner from entering the steering gear.

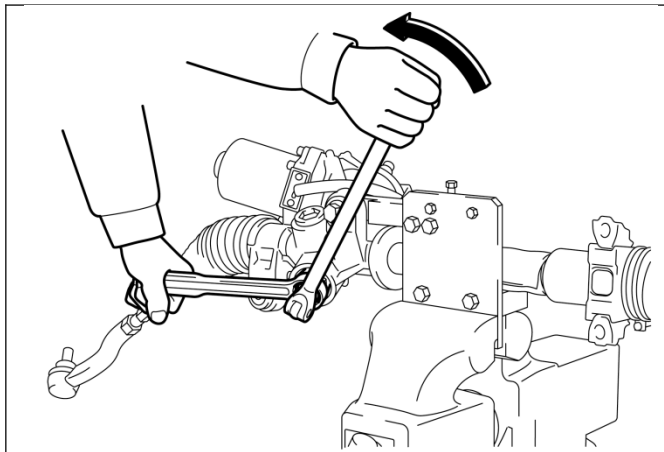

8. REMOVE THE PINION SHAFT LOCK NUT

- a) Use a paper towel to clean the grease from around the nuts.
- b) Use the adjusting nut holding tool to hold the adjusting nut while removing the lock nut.



DO NOT use brake cleaner or an air gun at this time, contamination may occur.

NOTE: If the lock nut is loose before removal, there is **NO** problem with reusing the gear.

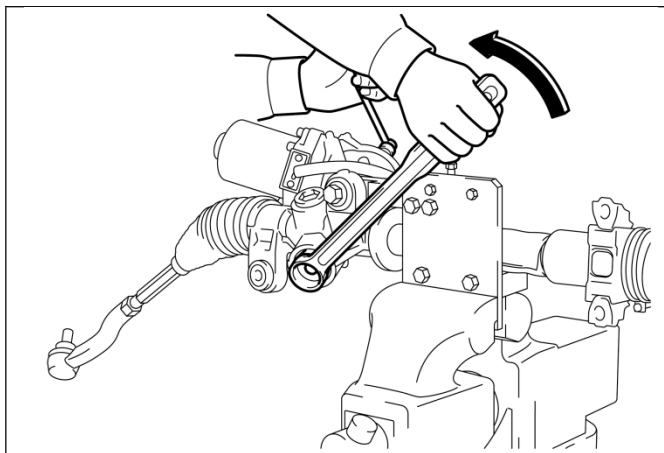

9. REMOVE THE PINION SHAFT ADJUSTING NUT

- a) Use the pinion shaft socket to hold the pinion shaft while removing the adjusting nut.

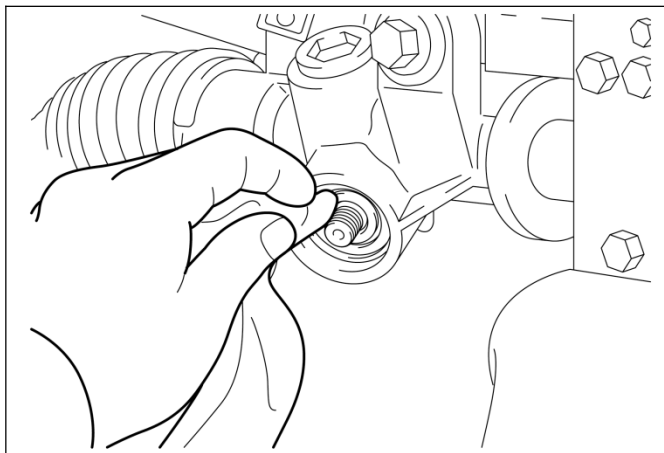

10. CLEAN INSIDE THE STEERING GEAR

- a) Use a paper towel to clean the inside of the steering gear.

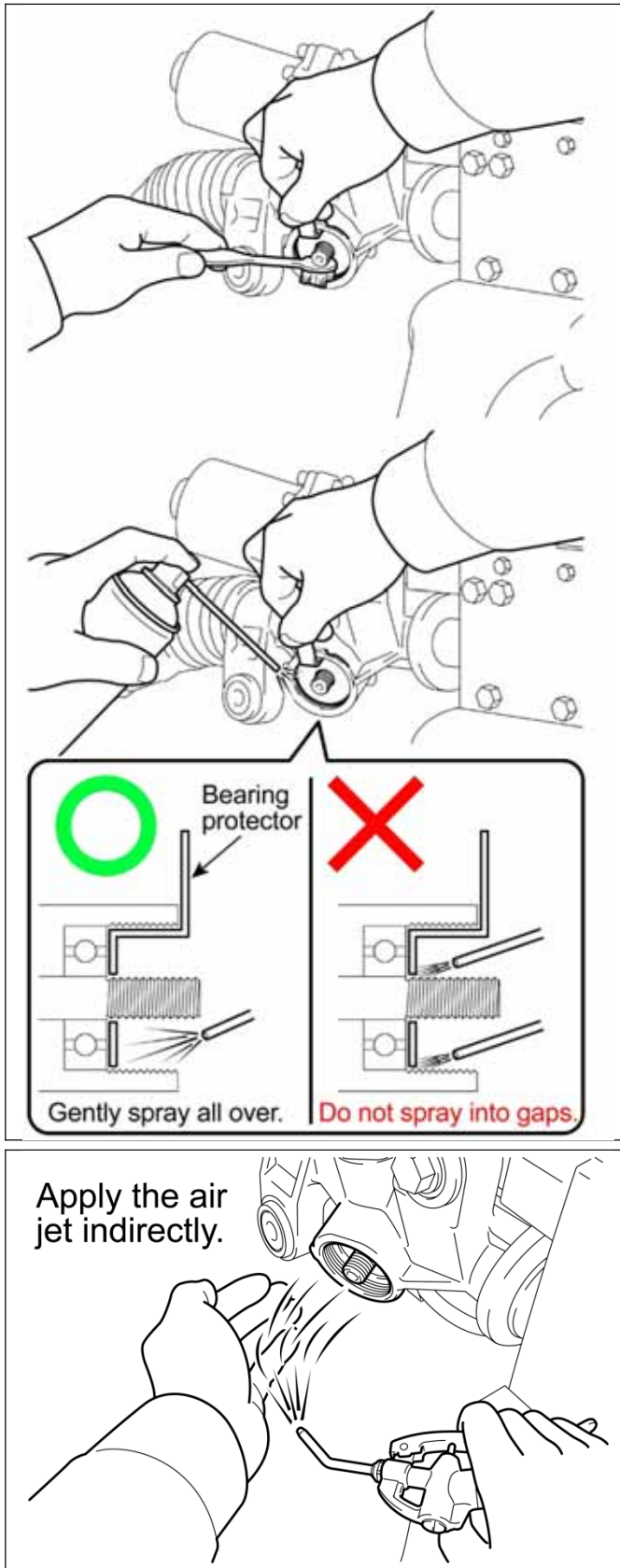

- b) Insert the bearing protector until it is fully seated against the bearing.
- c) Hold the bearing protector in place. Use a toothbrush and brake cleaner to clean the sealant and grease from the gear housing and pinion shaft threads.



- **DO NOT** spray brake cleaner directly at the bearing protector, contamination may occur.
- **DO NOT** use an air gun at this time, contamination may occur.
- **DO NOT** use a brush with wire bristles, it will scratch the aluminum housing.

- d) Use a paper towel to clean off all dirt and brake cleaner.

- e) Apply indirect air to dry the inside of the steering gear.



- **DO NOT** apply air directly, the bearing grease may be displaced.
- It is vital that the pinion shaft is fully cleaned of all grease, if grease is left on the shaft the new nuts may not install correctly.

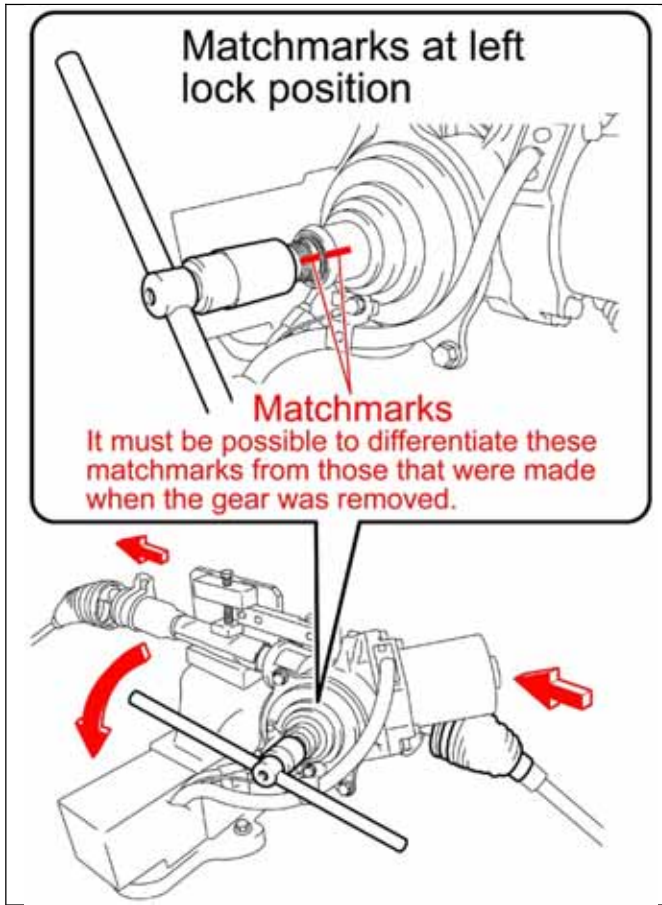

11. SECURE THE PINION SHAFT

- Turn the pinion shaft all the way to the left as shown in the illustration, then release the shaft. **The shaft may turn slightly back to the right, this is normal.**
- Add match marks to the pinion shaft and gear housing.

NOTE: Turning the pinion shaft to the left in this step should not be confused with turning the steering gear to the left as if making a left turn.



These steps *MUST* be followed to confirm that the pinion shaft does not rotate when the new pinion shaft nuts are installed.

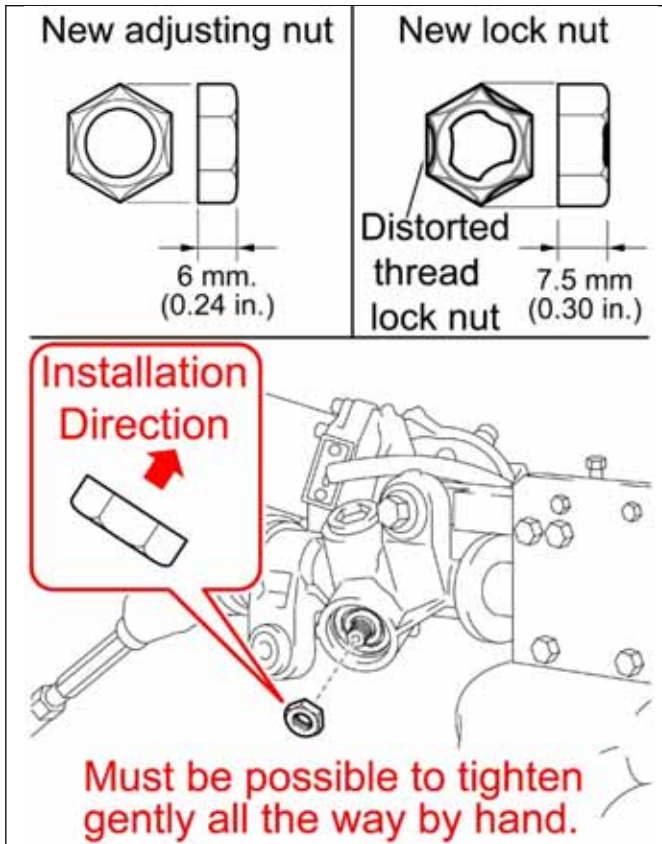

12. INSTALL THE PINION SHAFT ADJUSTING NUT

- Gently screw on the **NEW** adjusting nut while paying attention to the direction of installation.



- Confirm all grease is removed from the pinion shaft before installing the new nuts.
- If the pinion shaft threads are damaged and it is not possible to gently tighten the nut, the steering gear assembly **MUST** be replaced.

Pinion Shaft Nuts		Notes
Adjusting Nut	New	Thickness: 6.0mm Green chemical applied to nut (friction stabilizer)
	Old	Thickness: 7.5mm
Lock Nut	New	Thickness: 7.5mm Distorted thread locknut
	Old	Thickness: 7.5mm

NOTE: The green substance that is applied to the adjusting nut is a friction stabilizing coefficient agent. **DO NOT** remove it from the nut.

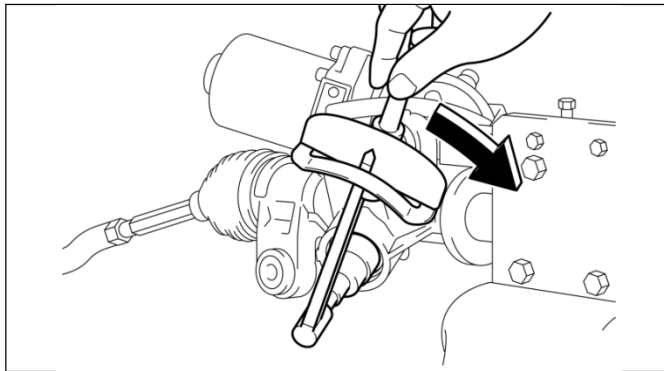

13. TIGHTEN THE PINION SHAFT ADJUSTING NUT

- a) Using the torque wrench (00002-02955), tighten the **NEW** adjusting nut to the specified torque.
Torque: 1.5Nm (15.2kgf cm, 13.3 in lbf)

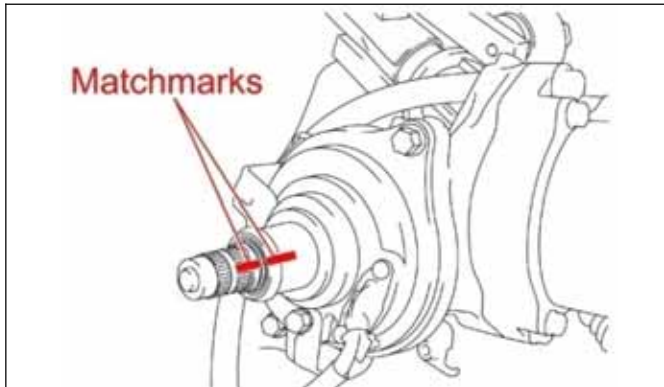

14. INSTALL AND TIGHTEN THE PINION SHAFT LOCK NUT

- a) Confirm the match marks on the pinion shaft are aligned correctly.



STOP

- If the new lock nut is installed then removed and the pinion shaft threads are damaged, the steering gear assembly should be replaced.
- If the pinion shaft or the adjusting nut rotates when tightening the lock nut, preload will be set incorrectly.

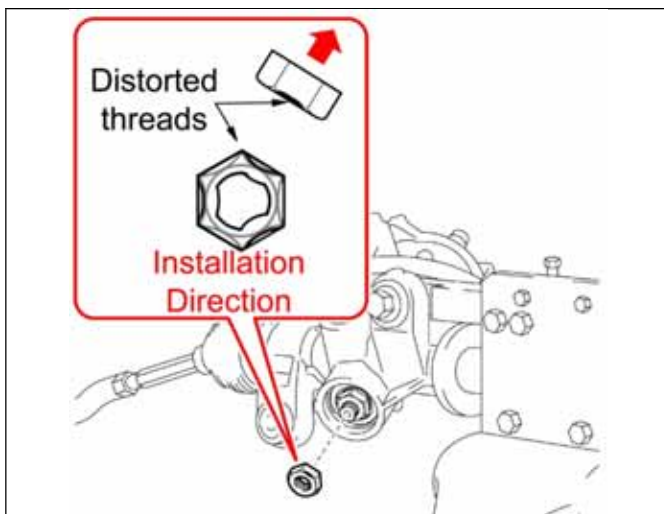

- b) By hand, screw on the **NEW** lock nut while paying attention to the direction of installation.

NOTE: Confirm the flat side of the lock nut is facing the adjusting nut.

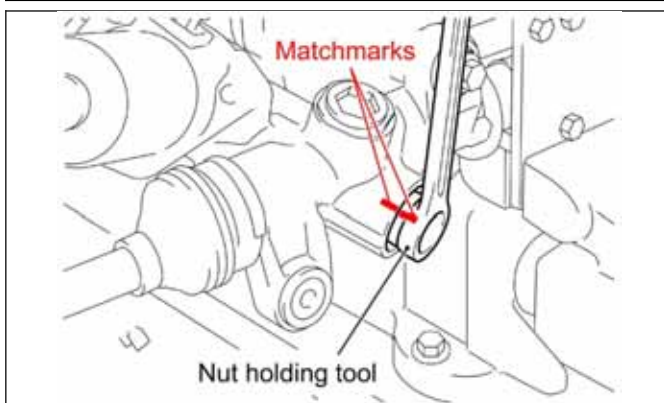

- c) With the adjusting nut held by the holding tool, add match marks to the tool and gear.



STOP

- If the holding tool moves the adjusting nut, the nut **MUST** be loosened and retorqued.
- The match marks are an important reference to determine if the adjusting nut moves.
- Looseness between the holding nut and adjusting tool is normal.

d) Tighten the lock nut while holding the adjusting nut with the holding tool.

Torque: 48 Nm (489 kgf cm, 35 ft lbf)

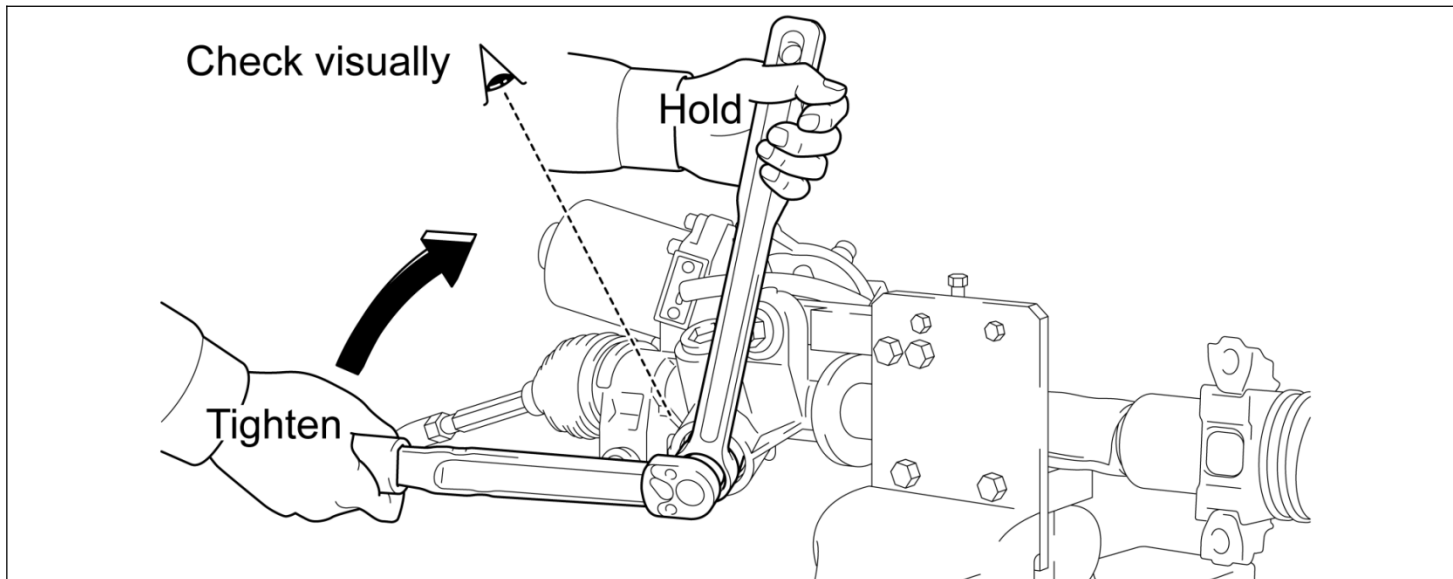

- **DO NOT** overtorque, steering wheel operation will become heavier than intended.
- When using a click-type torque wrench, only tighten until the **FIRST** click is heard, otherwise the nut will be overtorqued.
- If the match marks on the pinion shaft and gear or the holding tool and gear are not aligned after tightening the lock nut, the steering gear should be replaced.

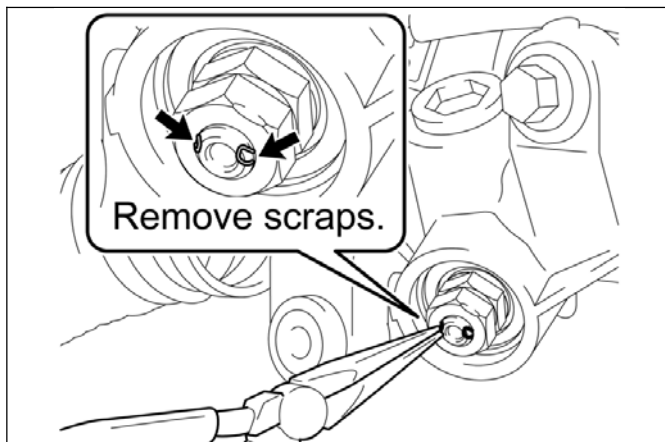

15. REMOVE THE PINION SHAFT GRINDINGS

- a) Use needle nose pliers to remove the grindings produced when installing the lock nut.

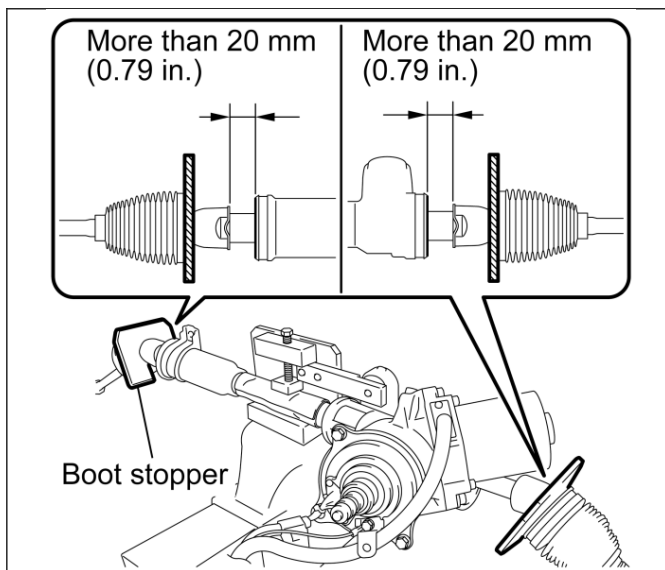

16. CHECK THE PINION SHAFT PRELOAD

- a) Position the steering gear in the straight ahead position (Approximately 2 turns from full lock position).



- If the rack boot stoppers are not installed, the preload measurement **WILL NOT** be accurate.
- Because the steering gear uses a variable gear ratio, preload **MUST** be measured with the steering gear in the straight ahead position.

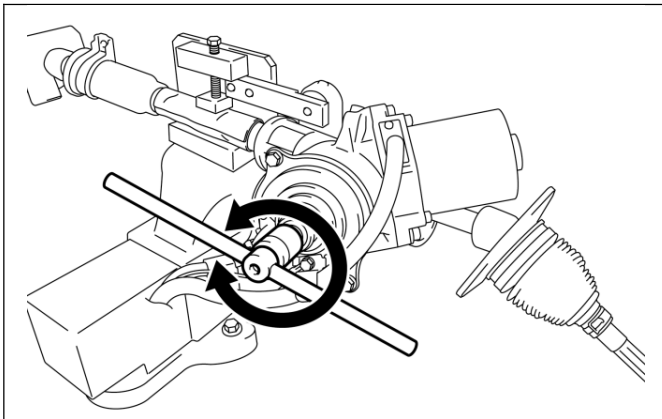

- b) Set the pinion shaft by performing the following a total of 3 times: Rotate the shaft 1 rotation right of center then 1 rotation left of center.

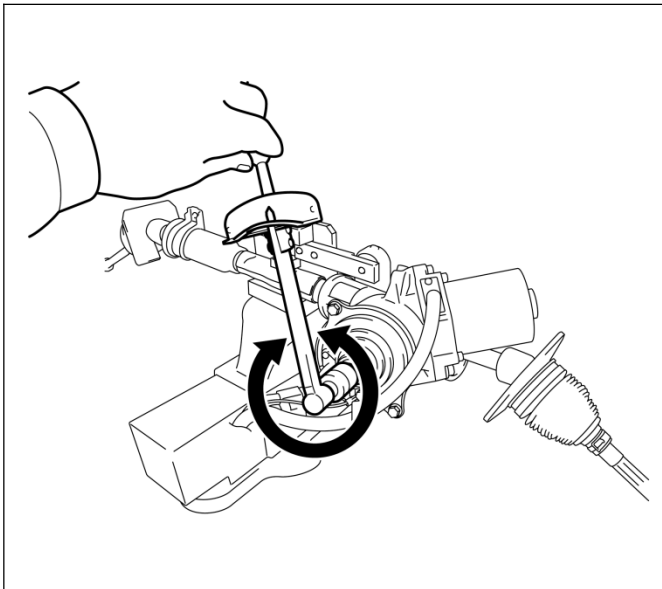

- c) Rotate the pinion shaft 1 complete rotation to the **right** using the torque wrench (00002-02955).
 d) Return the steering gear to the straight ahead position.
 e) Rotate the pinion shaft 1 complete rotation to the **left** using the torque wrench (00002-02955).

Specification: 0.5 to 2.5 Nm (0-22in. lbf) within 1 rotation of straight ahead position

Rotation Speed: Approx. 3 seconds per rotation



- It is normal if the preload is different between right and left rotation.
- Keep the rotation speed constant.
- **DO NOT** measure instant torque needle fluctuations.

NOTE: If the preload is not within specifications, replace the steering gear assembly.

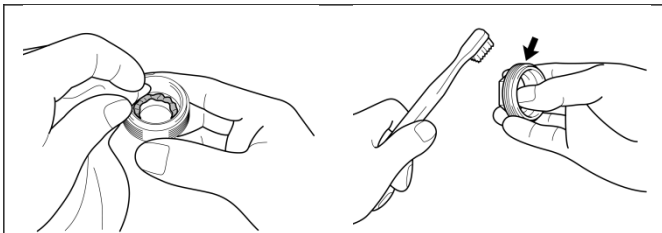

17. CLEAN THE RACK HOUSING CAP

- a) Clean the grease from inside the cap.
NOTE: It is NOT necessary to add more grease.
 b) Use a toothbrush and brake cleaner to clean the sealant on the threads of the cap.

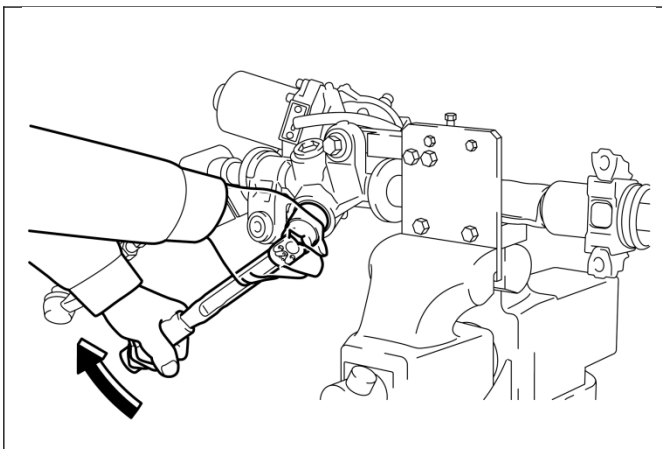

18. INSTALL THE RACK HOUSING CAP

- a) Apply Toyota Genuine Adhesive 1344 (or equivalent) to the cap threads.
 b) Install and tighten the cap.
Torque: 69 Nm (704 kgf cm, 51 ft lbf)
NOTE: Remove any excess Toyota Genuine Adhesive 1344 (or equivalent).



19. REPOSITION THE RACK GUIDE SPRING CAP

- a) Use the hexagon wrench 24mm to rotate the cap approximately 180 degrees back to the original position.
- b) Confirm the match marks align correctly.

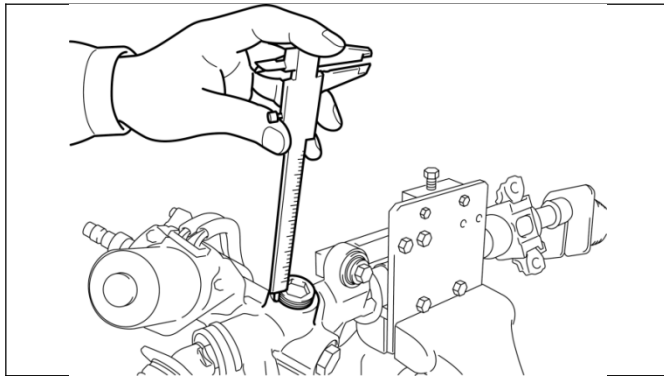

- c) Measure the amount of spring guide cap protrusion.
Specification: Approx. 7mm
If the protrusion does not meet the specification, it is possible that the cap is out of position by 1 rotation. (1 rotation is approximately 1.5mm)

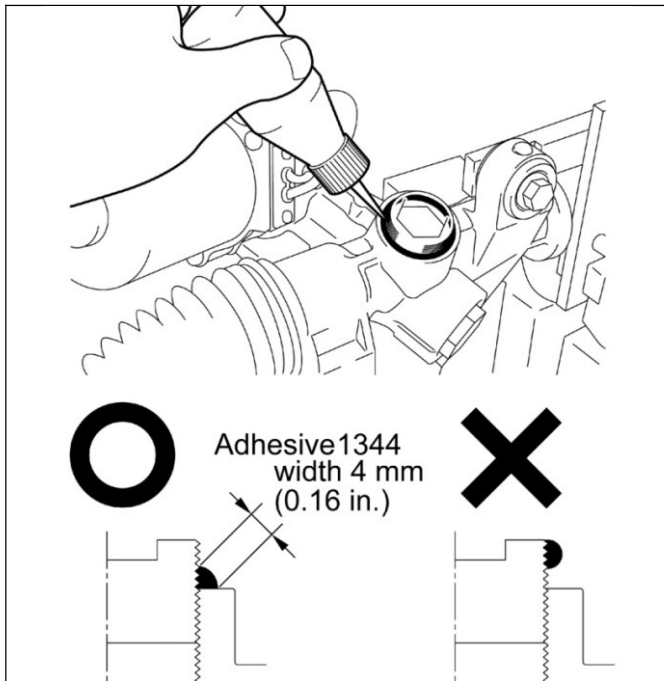

20. APPLY ADHESIVE TO THE RACK GUIDE SPRING CAP

- a) Apply Toyota Genuine Adhesive 1344 (or equivalent) to the corner of the spring cap and gear housing.

21. INSTALL THE RACK GUIDE SPRING CAP LOCK NUT

- a) Tighten the lock nut by hand.

NOTE: The lock nut can be installed in either direction.

- b) While holding the spring cap with the hexagon wrench 24mm, tighten the lock nut using the lock nut wrench and a torque wrench set to the **calculated torque** as described below.



- The calculated torque (C) is the value at which the torque wrench **MUST** be set.
- To determine the calculated torque, **READ** and **CLOSELY** follow the steps below.

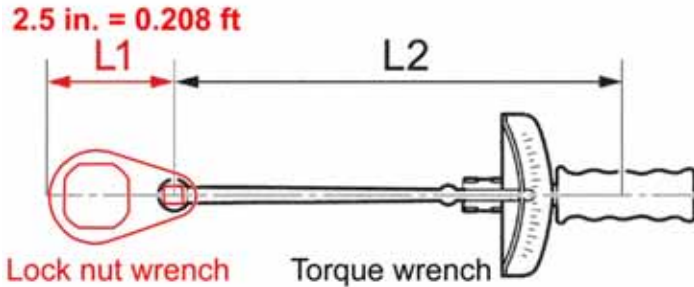

Connect the torque wrench to the lock nut wrench so that they form a straight line when tightening

- 1) Measure the length of the torque wrench from the center of the drive to the middle of the handle as shown in the illustration.
- 2) Determine the calculated torque (C) value to set the torque wrench to by referencing the table below.

Torque Wrench (L2) Length (in.)	Calculated Torque (C) (ft lbf)
10"	43 (ft lbf)
11"	40 (ft lbf)
12"	37 (ft lbf)
13"	34 (ft lbf)
14"	32 (ft lbf)
15"	30 (ft lbf)
16"	28 (ft lbf)
17"	27 (ft lbf)
18"	26 (ft lbf)
19"	24 (ft lbf)
20"	23 (ft lbf)

NOTE:
The lock nut wrench provided **MUST** be used when using the values in the table.

Calculated Torque (C) Formula:

If the lock nut wrench is not available, use this formula. $C = (51 \text{ ft lbf}) \times L2 / (L1 + L2)$

- c) Confirm the match marks are aligned after tightening the lock nut.



If the match marks are misaligned by more than 2mm, noise and excessive steering force may occur.

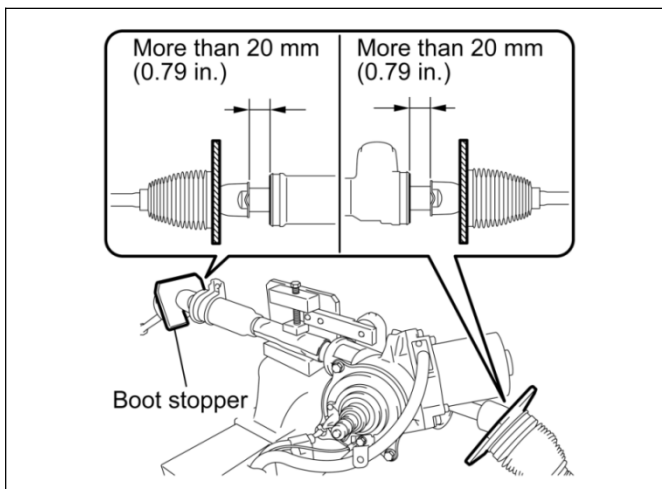
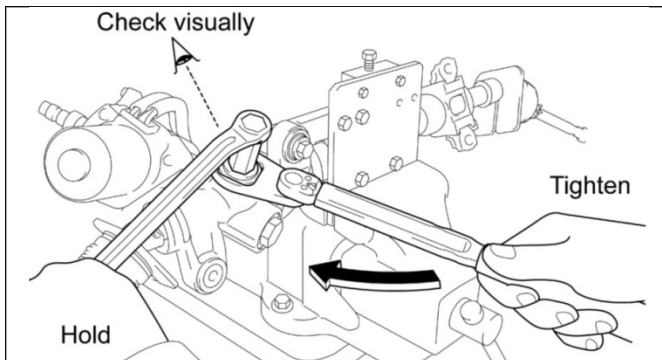

22. CHECK THE OVERALL PRELOAD

- Position the steering gear in the straight ahead position (Approximately 2 turns from full lock position).
- Set the pinion shaft by performing the following a total of 3 times: Rotate the shaft 1 rotation right of center then 1 rotation left of center.



- If the rack boot stoppers are not installed, the preload measurement **WILL NOT** be accurate.
- Because the steering gear uses a variable gear ratio, preload **MUST** be measured with the steering gear in the straight ahead position.

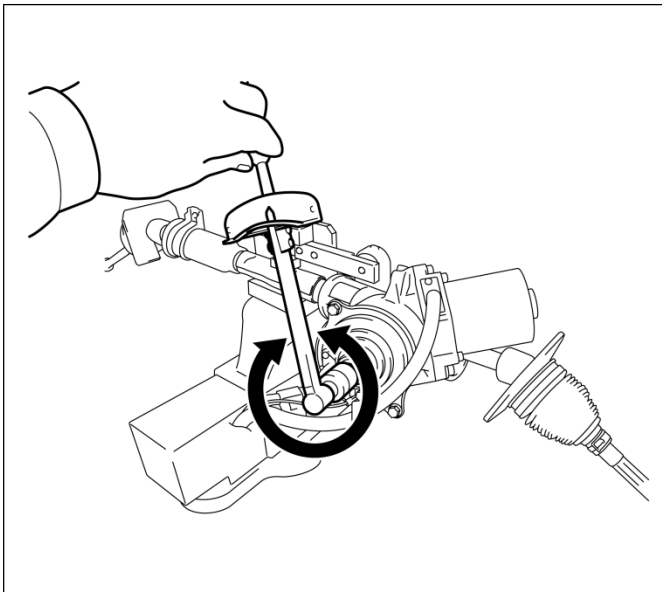

- c) Rotate the pinion shaft 1 complete rotation to the **right** using the torque wrench (00002-02955).
- d) Return the steering gear to the straight ahead position.
- e) Rotate the pinion shaft 1 complete rotation to the **left** using the torque wrench (00002-02955).

Specification: 1.0 to 3.0 Nm (9-26.5in. lbf) within 1 rotation of straight ahead position

Rotation Speed: Approx. 3 seconds per rotation



- It is normal if the preload is different between right and left rotation.
- Keep the rotation speed constant.
- **DO NOT** measure instant torque needle fluctuations.

NOTE: If the preload is not within specifications, replace the steering gear assembly.

23. INSTALL THE STEERING GEAR RACK BOOTS

- a) Position the steering gear in the straight ahead position (Approximately 2 turns from full lock position).
- b) Remove the rack boot stoppers.
- c) Attach the rack boots to the gear housing.
- d) Align the boot and clamp marks and tighten the clamp screws.

NOTE:

- **DO NOT** remove the screws from the clamps, the clamps may become deformed allowing water entry into the boot.
- The boots **MUST** be installed on the gear by hand to prevent scratching the gear or puncturing the boot.
- If the clamps are misaligned during installation, they may interfere with the crossmember during installation.

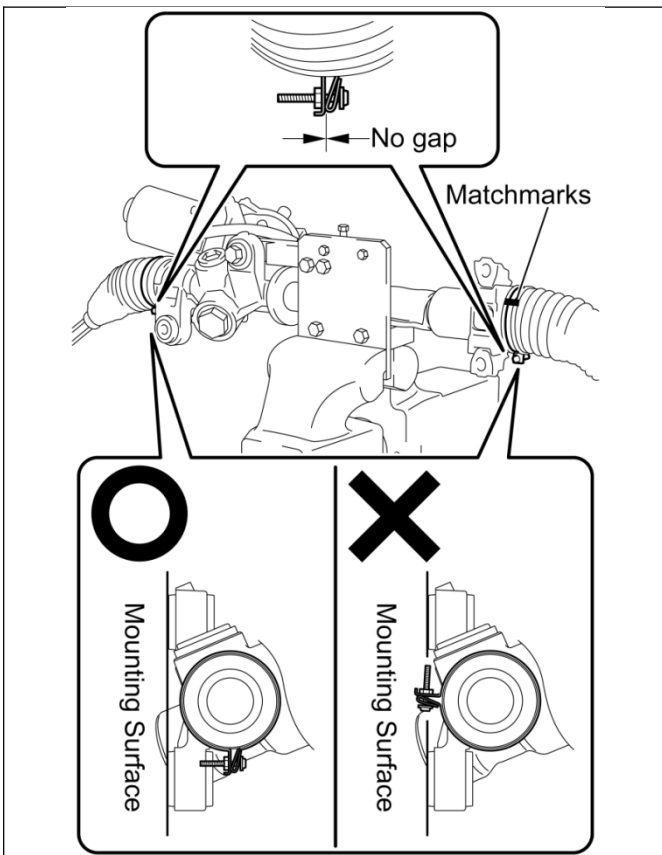

- e) Move the steering gear from lock to lock to check the boots contract and expand smoothly.
- f) Position the steering gear in the straight ahead position (Approximately 2 turns from full lock position) and proceed to **SECTION VIII. POWER STEERING GEAR INSTALLATION.**

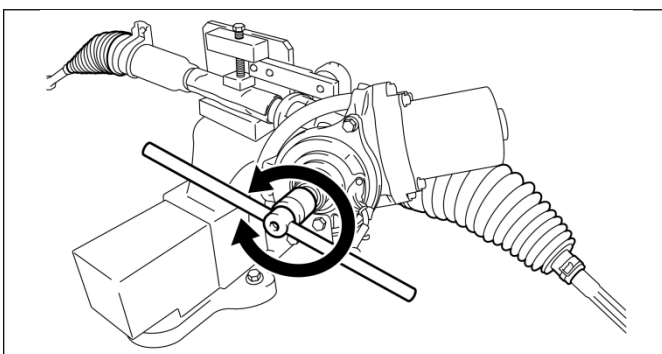

X. POWER STEERING GEAR INSTALLATION

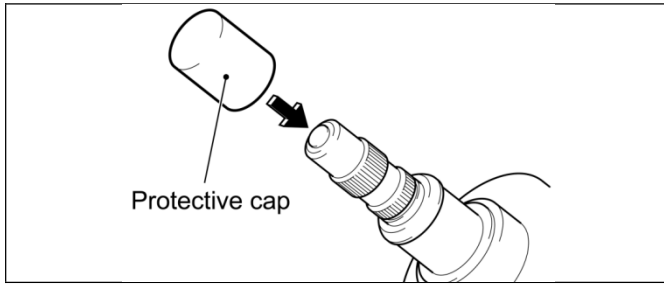

1. INSTALL THE PINION SHAFT PROTECTIVE CAP

2. INSTALL THE STEERING GEAR ASSEMBLY

a) Install the steering gear assembly in the reverse order of removal.



- The new parts in the parts kit **MUST** be used during installation.
- Refer to the removal steps for assistance.

**THE FOLLOWING INSTALLATION STEPS ARE VITAL.
CONFIRM THESE STEPS ARE FOLLOWED CLOSELY.**

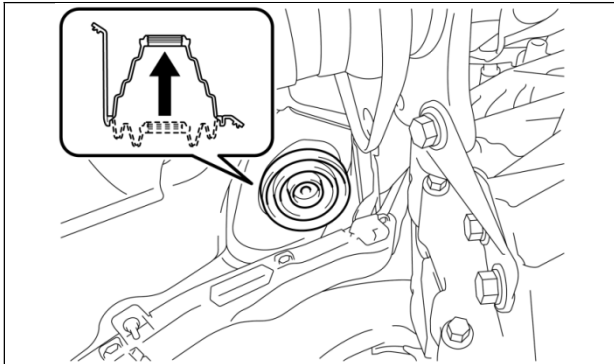

A. POSITION THE STEERING GEAR MAIN SHAFT DUST SEAL

1) Position the dust seal so that it is protruding into the interior of the vehicle.

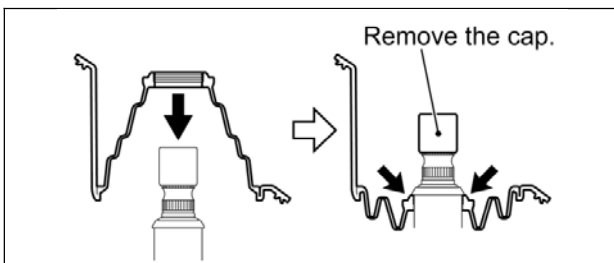

2) Position the dust seal on the shaft correctly.

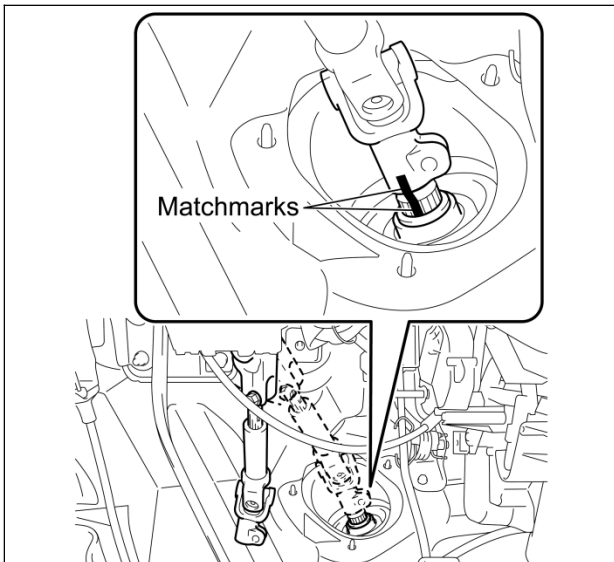

B. INSTALL THE STEERING INTERMEDIATE SHAFT ASSY NO. 2

1) Align the match marks when connecting the shaft.

- 2) Confirm the shaft is fully installed.
- 3) Install the bottom bolt.
Specification: 35Nm (360kgf cm, 26 ft lbf)
- 4) Install the top bolt.
Specification: 35Nm (360kgf cm, 26 ft lbf)

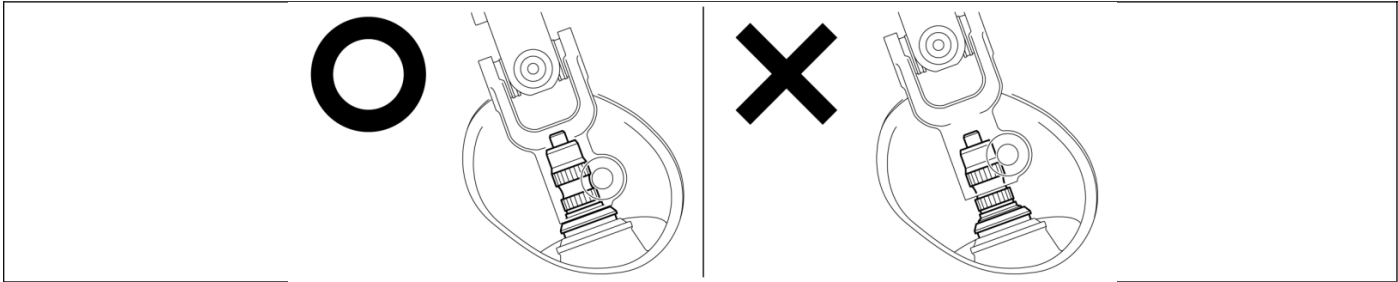

3. INSTALL THE INSTRUMENT PANEL FINISH LOWER PANEL
4. ALIGN THE VEHICLE

**THE FOLLOWING STEPS ARE VITAL.
CONFIRM THESE STEPS ARE FOLLOWED CLOSELY.**

5. PERFORM THE TORQUE SENSOR ADJUSTMENT CALIBRATION

- a) Use a Techstream to perform the calibration.

NOTE: If the calibration fails to complete after attempting AT LEAST 3 times, the steering gear should be replaced.

6. REMEASURE THE STATIONARY STEERING TORQUE

- a) Position the vehicle on the same surface used when taking the initial readings.
- b) Install the torque wrench attachment to the steering wheel
- c) Connect the SST torque wrench (00002-02955).
- d) Turn vehicle to READY ON.
- e) Start with the wheels straight ahead. Turn the steering wheel ¼ turn to the left of center, then ¼ turn to the right of center using the torque wrench.
- f) Record the right and left steering torque values.



- This information can be used when explaining the change in the steering effort that may result from this work.
- If there is a noticeable difference in steering feel, the pinion shaft nuts may not have been set correctly. The steering gear should be replaced.
- **DO NOT** perform this inspection on alignment slip plates or on an epoxy covered shop floor.

7. TEST DRIVE THE VEHICLE TO CONFIRM THE REPAIR

◀ VERIFY REPAIR QUALITY ▶

- Confirm the lot number before replacing the pinion shaft double nuts
- Confirm ALL removal steps in the TI are followed, **DO NOT** completely remove the crossmember
- Confirm ALL pinion shaft double nut replacement steps are followed precisely
- Confirm the pinion shaft preload is set exactly as described in the TI
- If you have any questions regarding this recall, please contact your regional representative

XI. APPENDIX

A. CAMPAIGN DESIGNATION DECODER

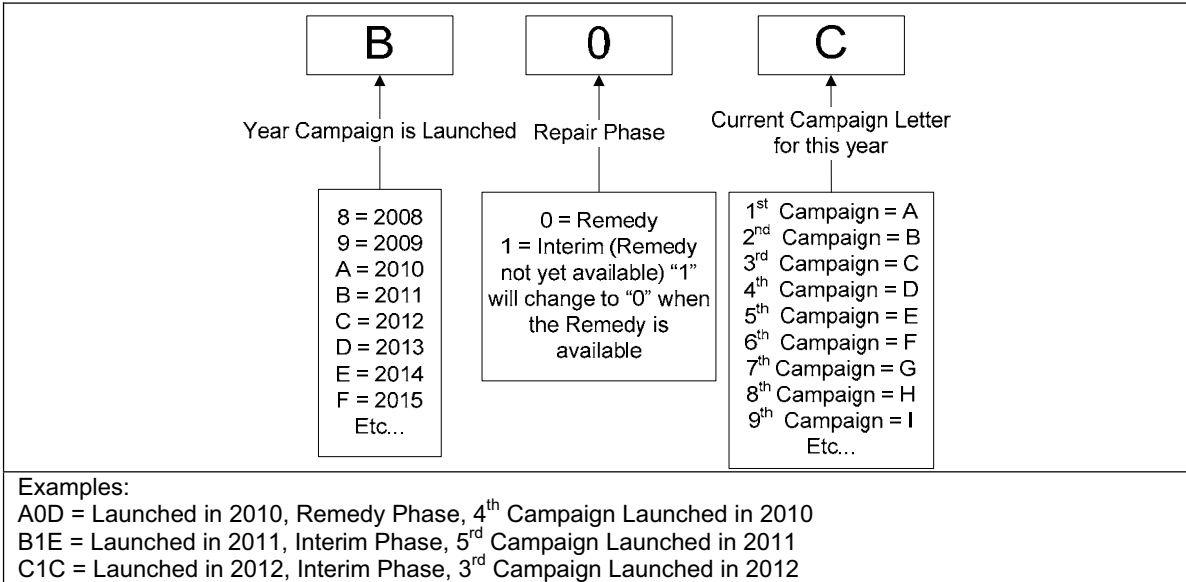

B. RECALL PARTS DISPOSAL

As required by Federal Regulations, please make sure all recalled parts (original parts) removed from the vehicle are disposed of in a manner in which they will not be reused, ***unless requested for parts recovery return.***

Tyson Siekiera / TMS Toyota Customer Services
Product Quality and Service Support, Quality Compliance
August 31, 2011
Approved By: Bob Waltz

To: All Toyota Dealers
From: Toyota Customer Services

2001 to 2003 Model Year Prius Vehicles
Replacement of Electric Power Steering (EPS) Pinion Shaft Nuts

*******UPDATE*******

- Toyota has updated the Technical Instructions to clarify several steps within the instructions

Please refer to the Technical Instructions found on TIS for full details on this update. Previous versions of the Technical Instructions should be discarded.

Thank you for your cooperation