

SERVICE PROCEDURE

**G-11508
JULY 2011**

**SUBJECT: SAFETY RECALL
RETURN FUEL VALVE on certain Holiday Rambler
Trip and Monaco Vesta models built 10/11/10 thru
2/18/11 with a MaxxFace 7 engine.**

DEFECT DESCRIPTION

A cap on the return fuel valve may become unsnapped allowing air to be drawn into the fuel system possibly resulting in engine hard start, no start, or stall conditions.

MODELS INVOLVED

This Safety Recall involves certain Holiday Rambler Trip and Monaco Vesta models built 10/11/10 thru 2/18/11 with a MaxxFace 7 engine.

PARTS INFORMATION

Part Number	Part Description	Quantity
7085437C91	Kit, RFV and Fuel Filter	1

7085437C91 contains the following parts:

Part Number	Part Description	Quantity
1891668C94	Return Fuel Valve Assembly Kit	1
	Fuel Housing Cover Gasket	1
	Fuel O-Ring	1
	Fuel Thermal Bypass Valve Assembly	1
	M5 x 18 Torx Screw	7
	Snap Ring	1
	Instruction Sheet	1
1884207C91	Fuel Filter Elements Kit	1
	Fuel Cap Primary O-Ring	1
	Fuel Cap Secondary O-Ring	1
	Fuel Primary Element Assembly	1
	Primary Filter Assembly	1
	Instruction Sheet	1

SERVICE PROCEDURE

WARNING! PARK VEHICLE ON HARD FLAT SURFACE, TURN THE ENGINE OFF, SET THE PARKING BRAKE AND BLOCK THE WHEELS TO PREVENT THE VEHICLE FROM MOVING IN BOTH DIRECTIONS. FAILURE TO DO SO MAY RESULT IN PROPERTY DAMAGE, PERSONAL INJURY AND/OR DEATH.

WARNING! IF THE VEHICLE MUST BE RAISED, DO NOT WORK UNDER THE VEHICLE SUPPORTED ONLY BY JACKS. JACKS CAN SLIP OR FALL OVER, POTENTIALLY RESULTING IN PROPERTY DAMAGE, PERSONAL INJURY AND/OR DEATH.

WARNING! ALWAYS WEAR SAFE EYE PROTECTION WHEN PERFORMING VEHICLE MAINTENANCE. FAILURE TO DO SO MAY RESULT IN SERIOUS EYE INJURY.

WARNING! ALLOW COMPONENTS IN ENGINE COMPARTMENT TO COOL BEFORE SERVICING ENGINE OR VEHICLE. FAILURE TO DO SO MAY RESULT IN PROPERTY DAMAGE, PERSONAL INJURY AND/OR DEATH.

1. Drain the low-pressure fuel system.

- a. Clean the primary fuel filter cap, secondary fuel filter cap, and fuel filter module assembly to prevent debris entering fuel system when removing caps.

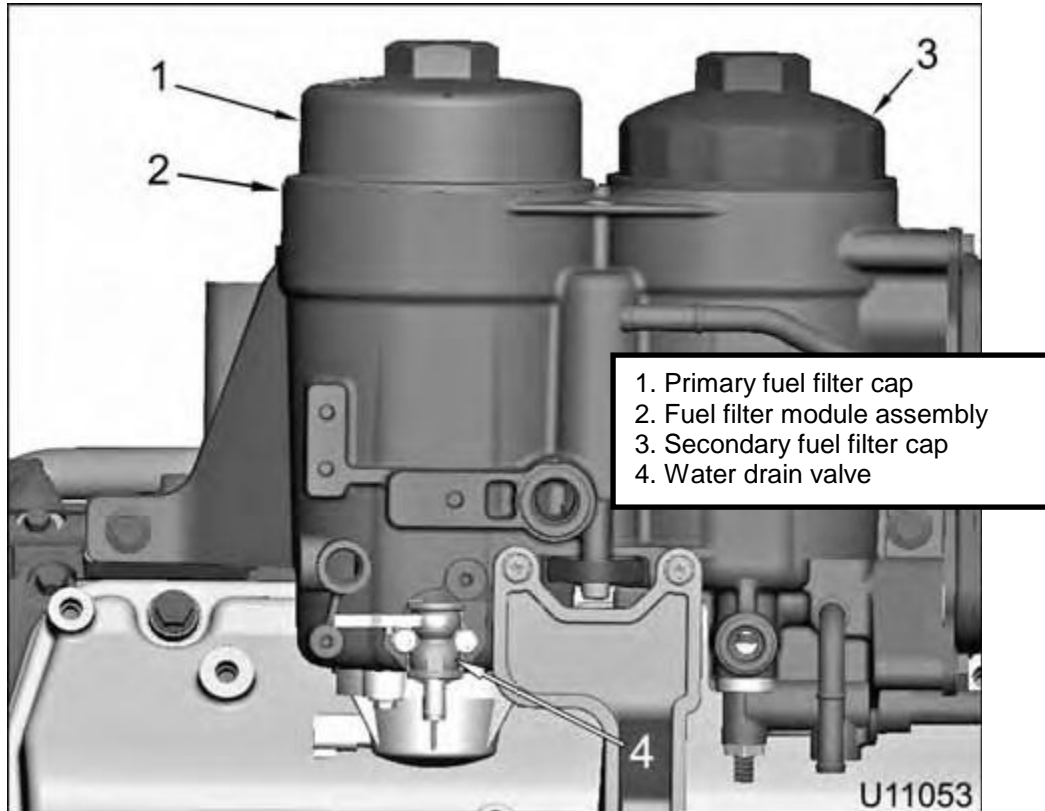

- b. Loosen the primary fuel filter cap counterclockwise three and one-half turns to vent the fuel filter module assembly.
- c. Attach a hose to the end of the water drain valve.
- d. Position a suitable container under the water drain valve and put end of hose into container.
- e. Open water drain valve and drain fuel.
- f. After fuel is drained remove container and recycle or dispose of fuel according to applicable regulations.
- g. Remove hose and close water drain valve.
- h. Turn the primary fuel filter cap clockwise to seat the cap to the fuel filter module assembly, but do not tighten to torque.

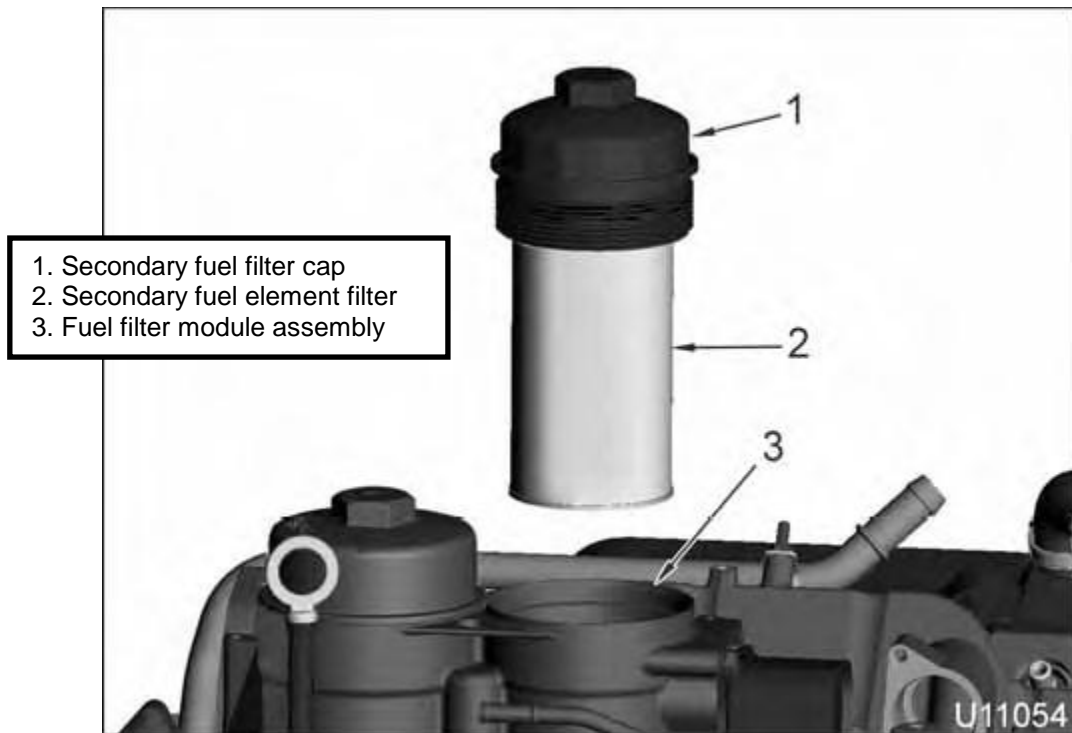

- i. Remove the secondary fuel filter cap and fuel element filter to allow fuel to drain to the tank.
- j. Reinstall the secondary fuel filter cap and fuel element filter to seat the cap to the fuel filter module assembly, but do not tighten to torque.

2. Install a new fuel thermal bypass valve assembly.

a. Remove the fuel filter module housing.

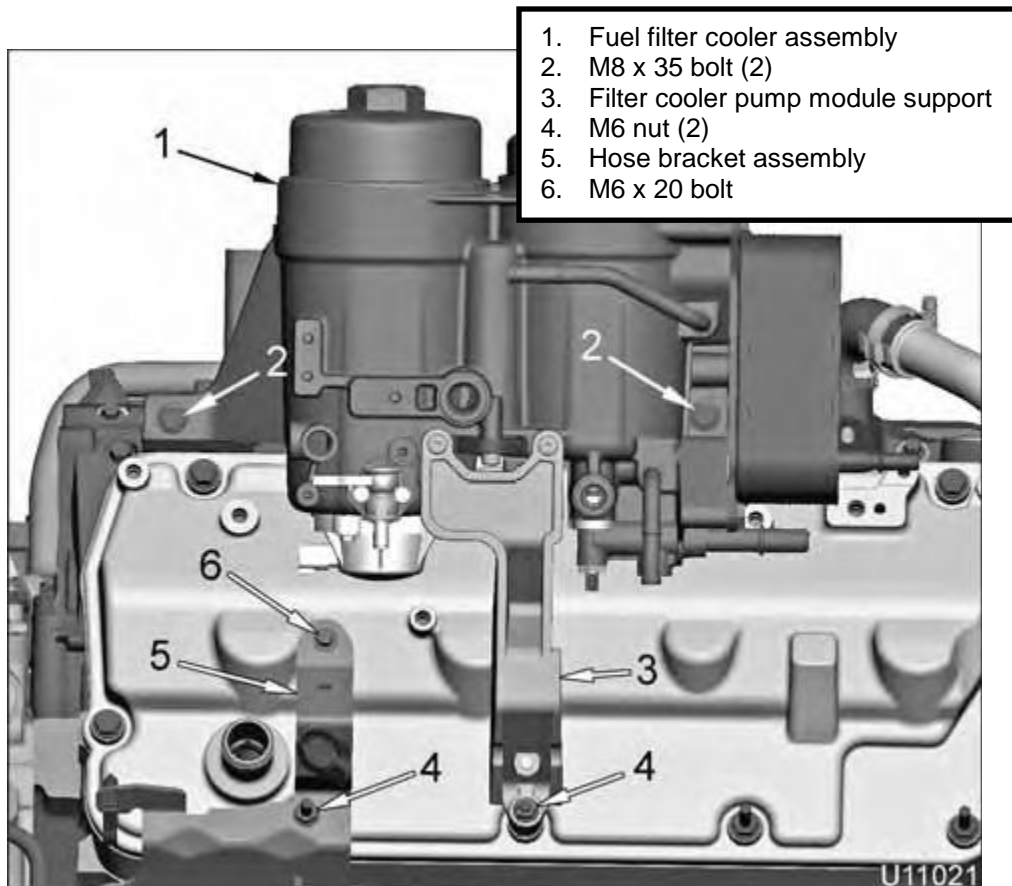

- i. Remove M6 nut from filter cooler pump module support.
- ii. Remove two M8 x 35 bolts that secure the fuel filter cooler assembly.
- iii. Remove fuel filter cooler assembly with filter cooler pump module support.
- iv. Remove M6 x 20 bolt, M6 nut, and the hose bracket assembly.

- b. Remove seven M5 x 18 screws that secure the fuel housing cover to the fuel filter module housing.

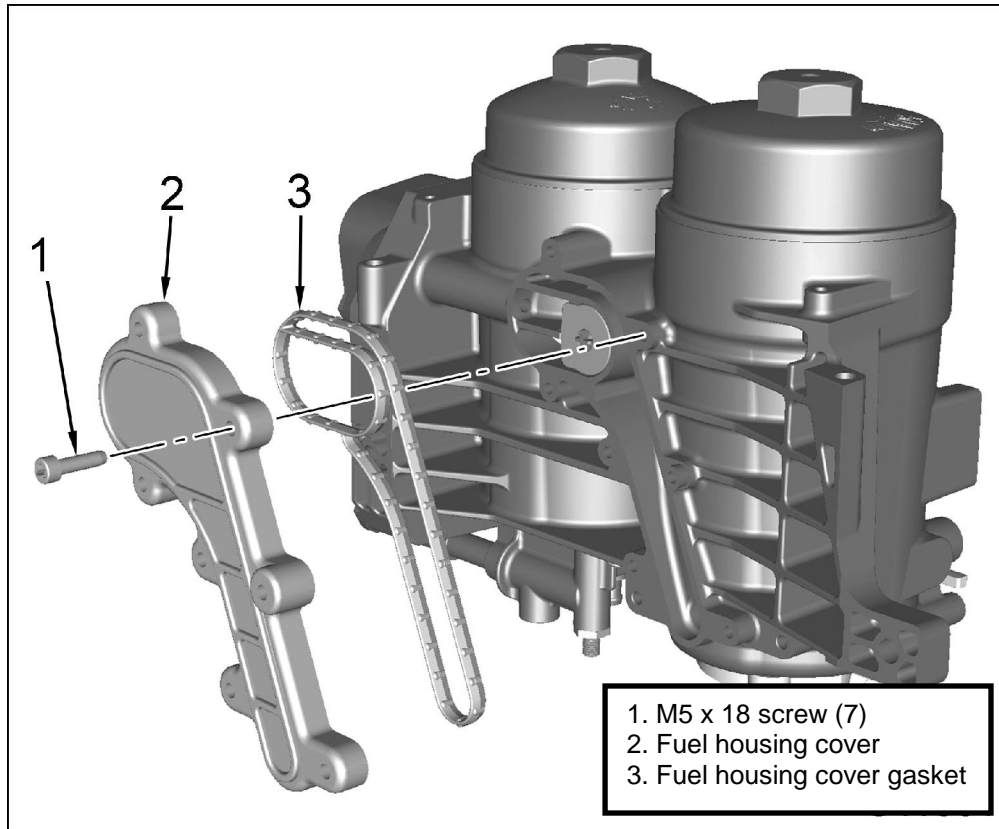

- c. Remove and discard the fuel housing cover gasket.
- d. Using a flat blade screw driver or needle nose pliers, remove the fuel thermal bypass valve assembly from fuel filter module housing. Care should be taken to prevent damage to the filter housing during the bypass valve removal.

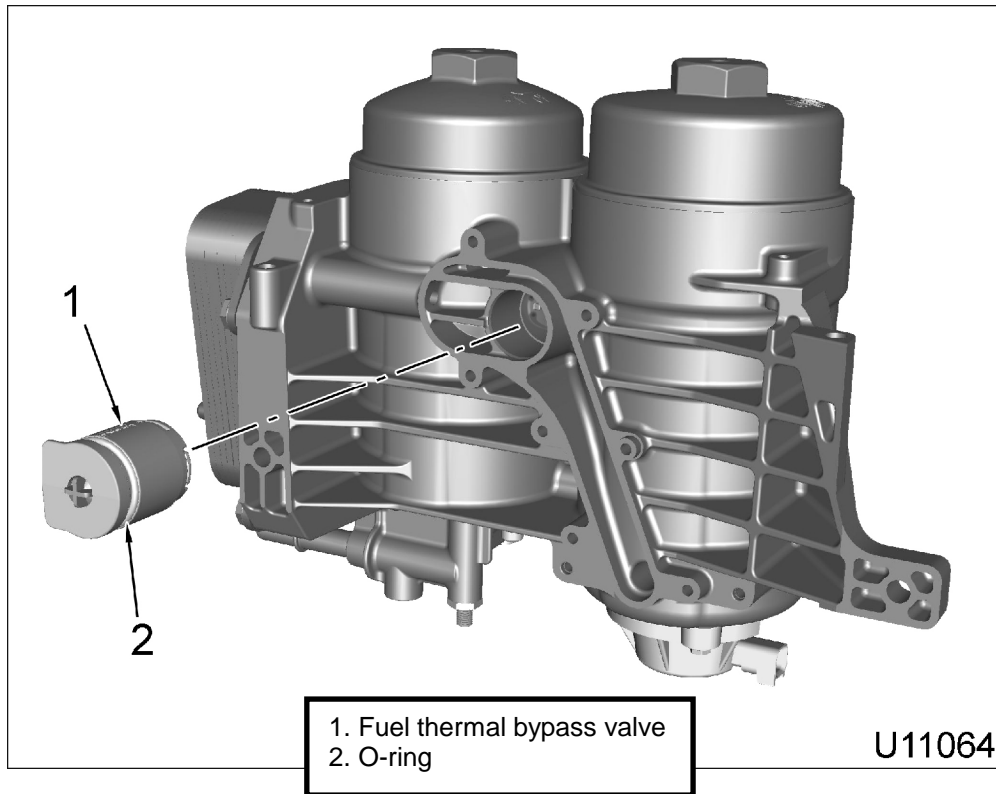

e. Discard the fuel thermal bypass valve assembly and fuel o-ring.

- f. Use retaining ring pliers to insert snap ring into the fuel thermal bypass valve bore until the snap ring stops on the two cast ribs at 12:00 o'clock and 6:00 o'clock positions.

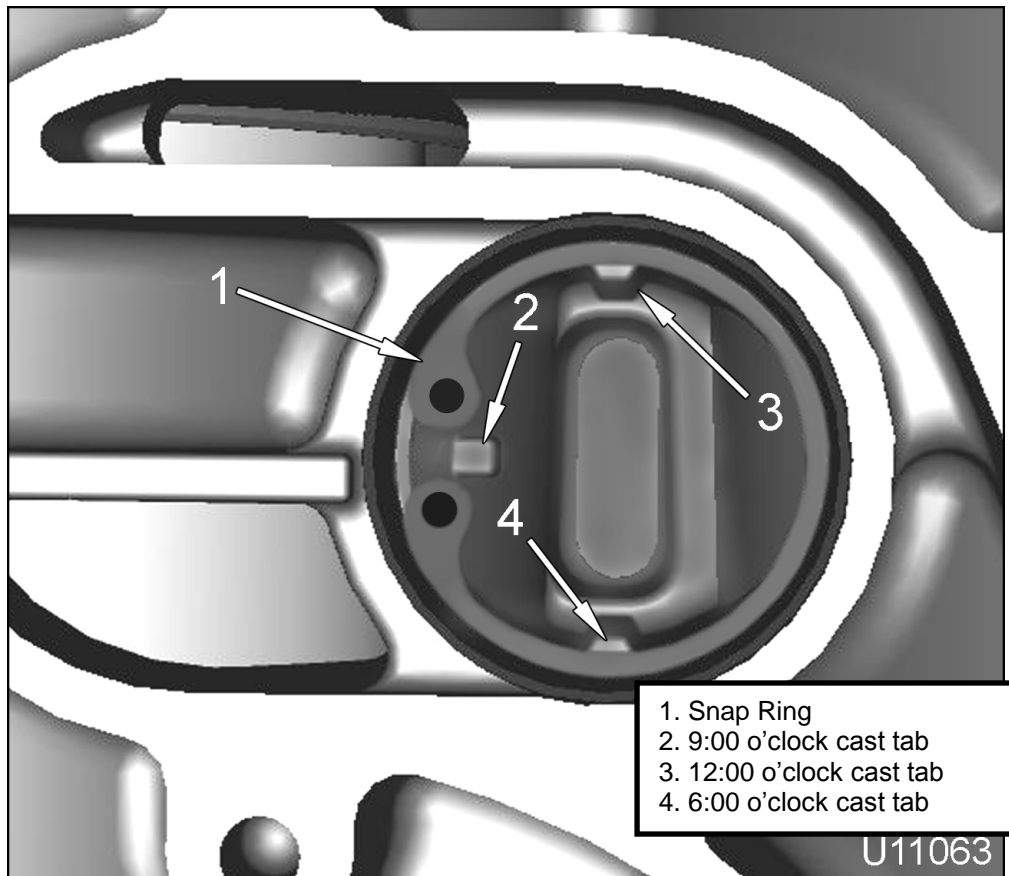

- g. Center the opening of the snap ring on the cast tab at the 9:00 o'clock position.

- h. Remove protective tie straps from fuel thermal bypass valve by cutting the outer tie strap first; then, slide the inner tie strap sideways off the fuel thermal bypass valve.

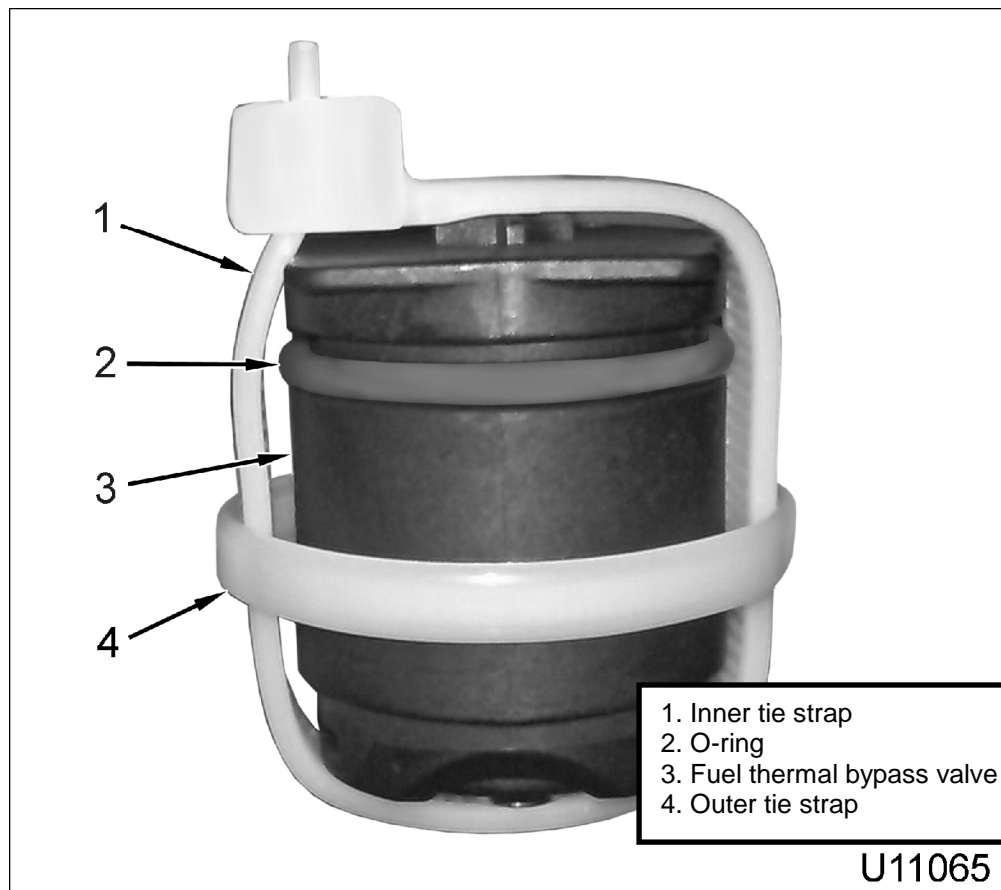

- i. Lubricate new fuel o-ring with clean diesel fuel.

- j. Insert new fuel thermal bypass valve assembly into valve bore until fully seated onto snap ring.

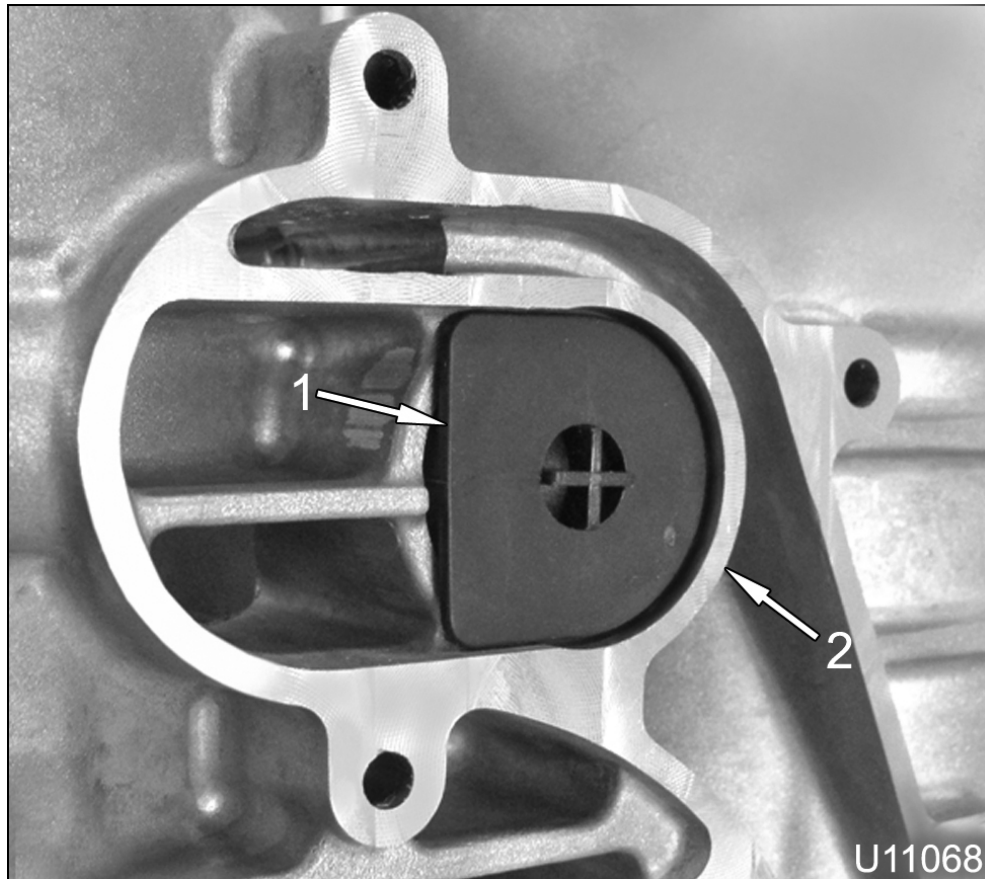

- k. Install new fuel housing cover gasket, fuel housing cover, and seven M5 x 18 screws.
- l. Tighten fuel housing cover screws to 5 N-m (45 lbf-in).

m. Install the fuel filter module housing.

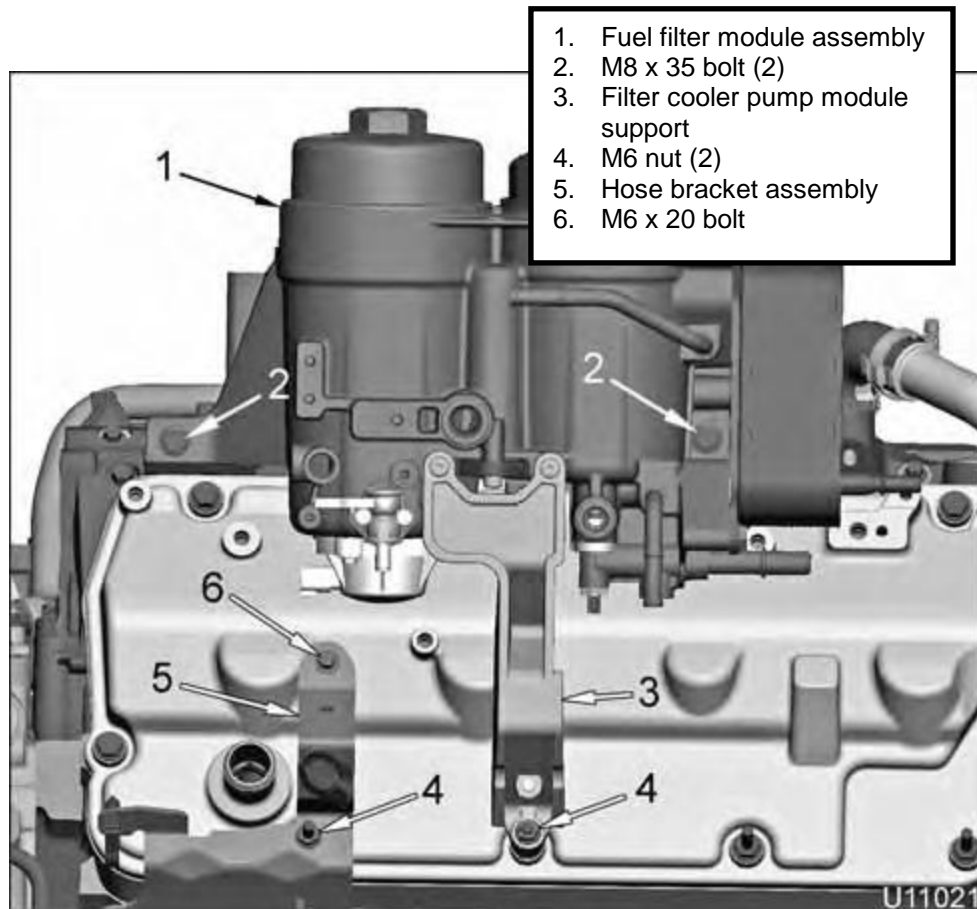

- i. Position fuel filter and cooler assembly with filter cooler pump module support onto engine.
 - ii. Install two M8 x 35 bolts to secure the fuel filter cooler assembly and tighten bolts to 31 N-m (23 lbf-ft).
 - iii. Install M6 nut to secure filter cooler pump module support and tighten nut to 13 N-m (115 lbf-in).
 - iv. Install hose bracket assembly, M6 x 20 bolt, and M6 nut.
 - v. Tight M6 x 20 bolt and M6 nut to 13 N-m (115 lbf-in).
3. Remove and replace the primary filter assembly, secondary fuel element assembly, both cap o-rings, and primary fuel element o-ring.

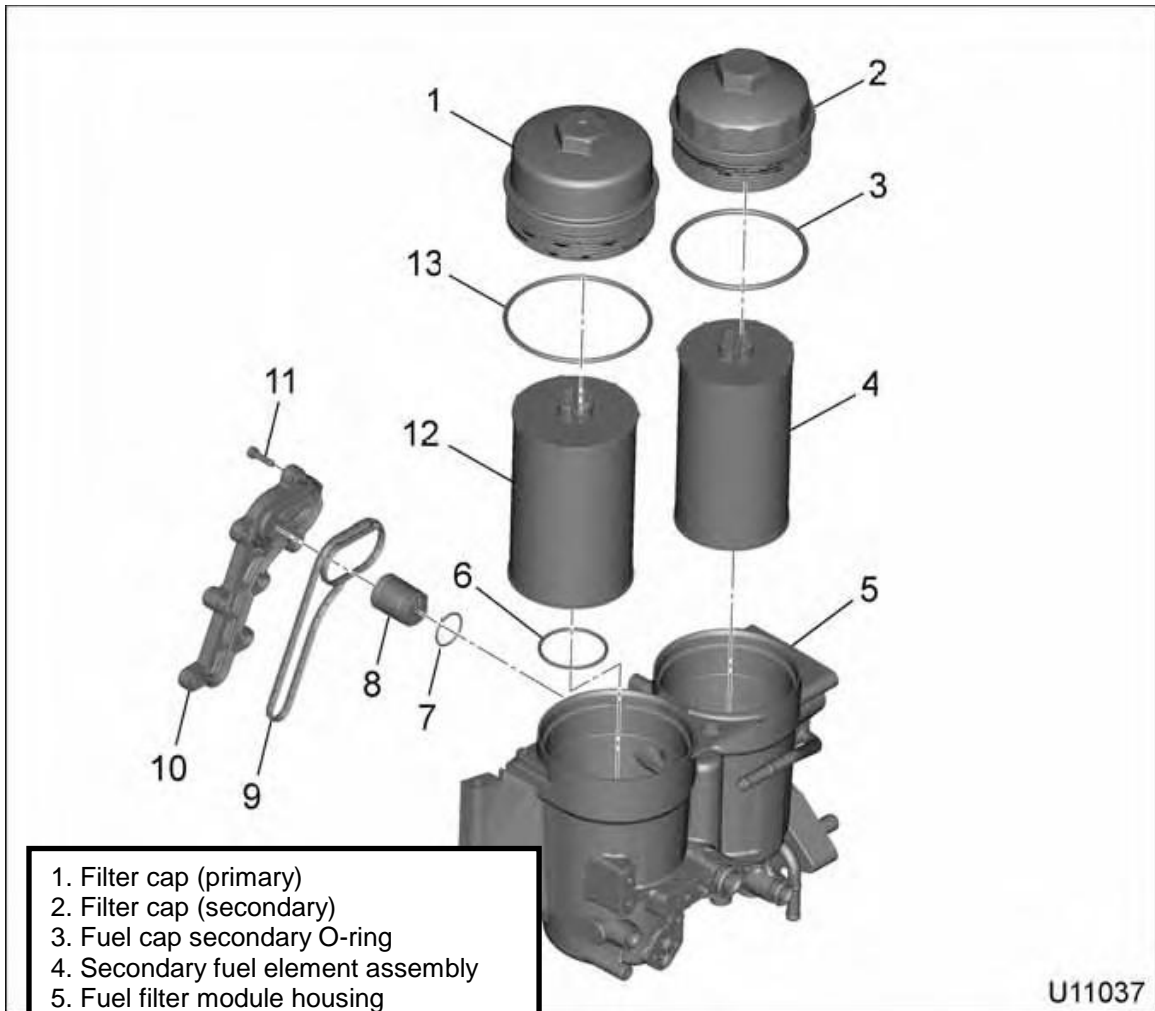

1. Filter cap (primary)
2. Filter cap (secondary)
3. Fuel cap secondary O-ring
4. Secondary fuel element assembly
5. Fuel filter module housing
6. Primary fuel element O-ring
7. Fuel O-ring
8. Fuel thermal bypass valve assembly
9. Fuel housing cover gasket
10. Fuel housing cover
11. M5 x 18 screw (7)
12. Primary filter assembly
13. Primary fuel cap O-ring

- a. Remove primary fuel filter cap.
- b. Remove and discard primary fuel cap O-ring, primary filter assembly, and primary fuel element O-ring.
- c. Remove secondary fuel filter cap.
- d. Remove and discard fuel cap secondary O-ring and secondary fuel element assembly.
- e. Coat a new O-ring for the primary fuel filter cap with clean diesel fuel and install onto the fuel filter cap.

- f. Attach fuel filter cap to a new filter assembly, by pushing the cap onto the filter assembly. The cap will snap onto filter assembly.
- g. Coat the threads of the fuel filter cap with clean diesel fuel.

NOTE: Verify that the primary fuel element O-ring is installed on the bottom of the primary filter assembly.

- If the O-ring is loose or not installed, coat the O-ring with clean diesel fuel and install the O-ring in the bottom groove of the primary filter assembly.

- If the O-ring is installed, coat the O-ring with clean diesel fuel.

CAUTION: To prevent engine damage, slowly install the primary fuel filter cap and filter assembly into the fuel filter module housing to prevent distortion of the O-ring.

- h. Slowly install the primary fuel filter cap and filter assembly into the fuel filter module housing.
- i. Secure the fuel filter cap and filter assembly into the fuel filter module housing by turning the fuel filter cap clockwise until finger-tight.
- j. Tighten the primary fuel filter cap to 50 N·m (37 lbf·ft).
- k. Coat a new O-ring for the secondary fuel filter cap with clean diesel fuel and install onto the primary fuel filter cap.
- l. Attach secondary fuel filter cap to a new fuel element assembly, by pushing the cap onto the fuel element assembly. The cap will snap into the element assembly.
- m. Coat the threads of the fuel filter cap with clean diesel fuel.
- n. Secure the fuel filter cap and fuel element assembly into the fuel filter module housing by turning the secondary fuel filter cap clockwise until finger-tight.
- o. Tighten the secondary fuel filter cap to 40 N·m (29 lbf·ft)

4. Prime the low pressure fuel system.

- a. Cycle engine ignition key.

- Key – On for 10 seconds.
 - Key – Off for 15 seconds.
 - Key – On for 10 seconds.
 - Key – Off for 15 seconds.
 - Key – On for 10 seconds.
- b. Start the engine and check for leaks.
- c. If leaks are found, shutdown the engine and correct the problem.

END OF SERVICE PROCEDURE

LABOR INFORMATION

Operation Number	Description	Time
A40-11508-1	Repair Return Fuel Valve	3.0
A40-11508-2	Add On: Vehicle Is Equipped With An Air Compressor	0.2

CAMPAIGN IDENTIFICATION LABEL

Each vehicle corrected in accordance with this campaign must be marked with a CTS-1075 Campaign Identification Label.

Complete the label and attach on a clean surface next to the vehicle identification number (VIN) plate.

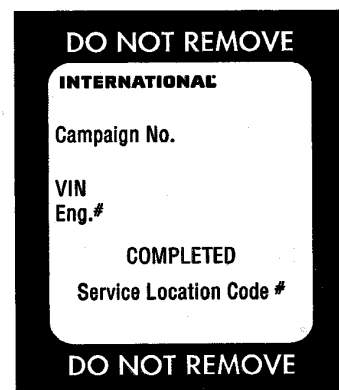

ADMINISTRATIVE/DEALER RESPONSIBILITIES

WARRANTY CLAIMS

Refer to Dealer Warranty Manual for procedures to conduct Recall Campaigns.

It is important that the Recall Coding be completed properly to assist in processing the warranty claim. Complete instructions will be found in the Warranty Manual, Section 7-1. Special attention should be given to Items 39 through 44:

	GROUP	NOUN	C	WARR.	TP	PAD
GROUP Enter number G—						
NOUN Leave blank						
C (CAUSE) Enter either 1, 2, 3. (see below)						
1. Inspected (No repair required).						
2. Inspected and repaired.						
3. Defective part from parts stock.						
WARRANTY (Warranty Code) Enter 40.						
TYPE PART Enter P for type part causing failure.						
PAD Enter 100						

UNITED STATES AND POSSESSIONS

The National Traffic and Motor Vehicle Safety Act, as amended, provides that each vehicle that is subject to a vehicle recall campaign must be adequately repaired within a reasonable time after the owner has tendered it for repair. A failure to adequately repair within 60 days after a tender of a vehicle is prima facie evidence of failure to repair within a reasonable time. If the condition is not adequately repaired within 60 days, the owner may be entitled to replacement with an identical or reasonable equivalent vehicle at no charge, or to a refund of the purchase price less a reasonable allowance for depreciation.

Dealers must correct all vehicles subject to this campaign at no charge to the owner, regardless of mileage, age of vehicle, or ownership, from this time forward.

Dealers should proceed immediately to make necessary correction to units in inventory. All inventory vehicles subject to this recall campaign must be corrected prior to sale, transfer or delivery. If vehicles have been sold or transferred and you are in receipt of Customer Notification Letters and Authorization for Recall Service cards for those vehicles, the transfer location or customer must be notified immediately from your dealer location.

Dealers must make every effort to promptly schedule an appointment with each owner to repair his or her vehicle as soon as possible. However, consistent with the customer notification, dealers are expected to complete the repairs on the mutually agreed upon service date.

Dealers involved in the recall process will be furnished a listing of owner names and addresses to enable them to follow up with owners and have the vehicles corrected. Use of this listing must be limited to this campaign because the list may contain information obtained from state motor vehicle registration records and the use of such motor vehicle registration data for purposes other than this campaign is a violation of law in several states.

CANADA

Dealers must correct all vehicles subject to this campaign at no charge to the owner, regardless of mileage, age of vehicle, or ownership, from this time forward.

Dealers should proceed immediately to make necessary correction to units in inventory. All inventory vehicles subject to this recall campaign must be corrected prior to sale, transfer or delivery. If vehicles have been sold or transferred and you are in receipt of Customer Notification Letters and Authorization for Recall Service cards for those vehicles, the transfer location or customer must be notified immediately from your dealer location.

Dealers must make every effort to promptly schedule an appointment with each owner to repair his or her vehicle as soon as possible. However, consistent with the customer notification, dealers are expected to complete the repairs on the mutually agreed upon service date.

Dealers involved in the recall process will be furnished a listing of owner names and addresses to enable them to follow up with owners and have the vehicles corrected. Use of this listing must be limited to this campaign because the list may contain information obtained from state motor vehicle registration records and the use of such motor vehicle registration data for purposes other than this campaign is a violation of law in several states.

EXPORT

Export Distributors should proceed immediately to make necessary correction to units in inventory. All inventory vehicles subject to this recall campaign must be corrected prior to sale, transfer or delivery. If vehicles have been sold or transferred and you are in receipt of Customer Notification Letters and Authorization for Recall Service cards for those vehicles, the transfer location or customer must be notified immediately from your distributor location.

Export Distributors are to submit warranty claims in the usual manner making reference to this recall number.

Export Distributors are expected to provide full cooperation and follow-up with respect to this important subject matter. If you have any questions or need further assistance, please contact the Regional Service Manager at your regional office.

NAVISTAR, INC